

# Installation & Operation Manual

## Central Air Conditioner

13 SEER 1.5 to 5.0 Tons

Models: HC18D2VAE HC24D2VAE  
HC30D2VAE HC36D2VAE  
HC42D2VAE HC48D1VAE  
HC60D1VAE



No. 0150505380 D

The information contained in this booklet is subject to change without notice.

# ! WARNING

- These instructions are intended as an aid to qualified, licensed service personnel for proper installation, adjustment and operation of this unit. Read these instructions thoroughly before attempting installation or operation. Failure to follow these instructions may result in improper installation, adjustment, service or maintenance possibly resulting in fire, electrical shock, property damage, personal injury or death.
- This product is designed and manufactured to permit installation in accordance with National Codes. It is the installer's responsibility to install the product in accordance with National Codes and/or prevailing local codes and regulations. The manufacturer assumes no responsibility for equipment installed in violation of any codes or regulations.
- The United States Environmental Protection Agency (EPA) has issued various regulations regarding the introduction and disposal of refrigerants in this unit. Failure to follow these regulations may harm the environment and can lead to the imposition of substantial fines. Because these regulations may vary due to the passage of new laws we suggest that any work on this unit be done by a certified technician. Should you have any questions please contact the local EPA office.
- The manufacturer's warranty does not cover any damage or defect to the air conditioner caused by the attachment or use of any components, accessories or devices (other than those authorized by the manufacturer) into, onto, or in conjunction with the air conditioner. **You should be aware that the use of unauthorized components, accessories or devices may adversely affect the operation of the air conditioner and may also endanger life and property.** The manufacturer disclaims any responsibility for such loss or injury resulting from the use of such unauthorized components, accessories or devices.  
Attach the service panel to the outdoor unit securely. If the service panel is not attached securely, it could result in a fire or an electric shock due to dust, water, etc.
- **Message to Owner**  
These instructions should be carefully read and kept near the product for future reference. While the instructions are addressed primarily to the installer, useful maintenance information is included. Have your installer acquaint you with the operating characteristics of the product and periodic maintenance requirements.

# TABLE OF CONTENT

1.Introduction -----	1
2.Nomenclature for Model Number -----	1
3.Specification -----	2
4.Unit Inspection -----	4
5.Equipment Protection From Environment -----	4
6.Installation -----	4
6.1. General -----	4
6.2.Unit clearances -----	5
6.3.Refrigerant piping -----	5
6.4.Electrical wiring -----	10
7.System Startup -----	11
8.Operation -----	12
9.Miscellaneous -----	12
9.1.Replacement parts -----	12
9.2.Troubleshooting guide -----	12
9.3.Wiring diagram -----	12

## 1.INTRODUCTION

This manual contains the installation and operating instructions for your new air conditioner. Improper installation can result in unsatisfactory operation or dangerous conditions. Carefully read this manual and any instructions packaged with separate equipment required to make up the system prior to installation. Give this manual to the owner and explain its provisions. The owner should retain this manual for future reference.

## 2.NOMENCLATURE FOR MODEL NUMBER

H	Brand symbol-H:Haier
C	System type-C:Air conditioner;R:Heat pump
24	Nominal capacity in (000) Btu/h
D	SEER designation. D=13,E=14
2	Design series. 1-1st Generation,2-2nd Generation
V	Electric:V=208/230-1-60;C=208/230-3-60;D=460-3-60,Y=575-3-60
A	Body style
E	Refrigerant type R:R22;E:R410A
	Example:HC24D2VAE

### 3.SPECIFICATION

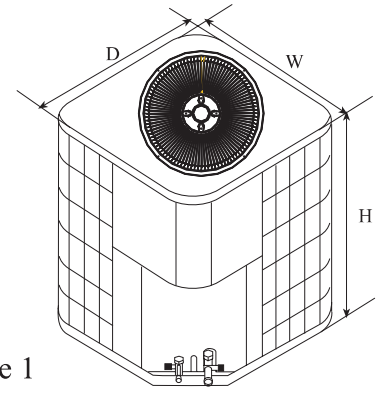

Figure 1

The dimensions for the condensing unit are illustrated in Figure 1. Physical and electrical specifications are provided in Table 1 for 13 SEER systems respectively.

The Figure 2 show a schematic of the cooling only system.

Table 1: Model:HC18-42D2VAE HC48-60D1VAE

MODEL:	HC18D2VAE	HC24D2VAE	HC30D2VAE	HC36D2VAE	HC42D2VAE	HC48D1VAE	HC60D1VAE
Unit Supply Voltage	208/230 60Hz 1PH						
Normal Voltage Range	197-253						
Minimum Circuit Amps	9.8	11.5	14.8	17.7	20.8	21.6	28.9
(HACR per NEC)	20	25	30	35	40	40	60
Compressor	Rated Load Amps	7.1	8.5	10.7	13.2	15.7	21.2
	Locked Running Amps	43	43	54	74	88	105
Fan Motor	Full Load Amps	0.9	0.9	1.4	1.2	1.2	2.4
	Rated HP	1/7	1/7	1/4	1/5	1/5	1/2
	Nominal RPM	1000	1000	1075	1120	1120	1000
Liquid Line OD-In(mm)	3/8"[9.52]	3/8"[9.52]	3/8"[9.52]	3/8"[9.52]	3/8"[9.52]	3/8"[9.52]	3/8"[9.52]
Vapor Line OD-In(mm)	3/4"[19.05]	3/4"[19.05]	3/4"[19.05]	3/4"[19.05]	7/8"[22.22]	7/8"[22.22]	7/8"[22.22]
R-410A Charge-Oz(g)	94[2680]	91[2580]	139[3930]	146[4130]	149[4230]	216[6130]	241[6830]
Net Dimensions-In(mm) W*D*H	21 1/2"*21 1/2"*26 7/8" [547*547*683]	21 1/2"*21 1/2"*26 7/8" [547*547*683]	24 1/4"*24 1/4"*26 7/8" [616*616*683]	24 1/4"*24 1/4"*30 3/8" [616*616*771]	24 1/4"*24 1/4"*30 3/8" [616*616*771]	30 5/8"*30 5/8"*32 3/16" [779*779*817]	30 5/8"*30 5/8"*40" [779*779*1017]
Shipping Dimensions-In (mm) W*D*H	23"*23"*28 1/2" [585*585*725]	23"*23"*28 1/2" [585*585*725]	26 7/8"*26 7/8"*28 1/2" [682*682*725]	26 7/8"*26 7/8"*32" [682*682*813]	26 7/8"*26 7/8"*32" [682*682*813]	32 1/2" *32 1/2" *33 1/2" [825*825*851]	32 1/2" *32 1/2" *41 3/8" [825*825*1051]
Net Weight-Lbs[kg]	150[68]	150[68]	178[81]	183[83]	185[84]	244[111]	290[132]
Approx Shipping Weight-Lbs[kg]	161[73]	161[73]	191[87]	196[89]	198[90]	262[119]	312[142]

Table 2: System Cooling Capacity

Cooling

Outdoor	Indoor	Indoor fan speed	ARI data of indoor			Cooling Capacity with different outdoor temperature							
			Capacity	SEER	CFM	80	85	90	95	100	105	110	115
HC18D2VAE	HB2400VD2M20	M	18000	13	680	20340	19746	19080	18000	17730	17460	17190	16920
HC24D2VAE	HB2400VD2M20	H	23000	13	900	25990	25231	24380	23000	22655	22310	21965	21620
HC30D2VAE	HB3600VD2M20	L	29000	13	1125	32770	31813	30740	29000	28565	28130	27695	27260
HC36D2VAE	HB3600VD2M20	H	34000	13	1300	38420	37298	36040	34000	33490	32980	32470	31960
HC42D2VAE	HB4800VD2M22	L	40000	13	1480	45200	43880	42400	40000	39400	38800	38200	37600
HC48D1VAE	HB4800VD2M22	H	47000	13	1580	53110	51559	49820	47000	46295	45590	44885	44180
HC60D1VAE	HB6000VD2M22	H	55500	13	1730	62715	60884	58830	55500	54668	53835	53003	52170

Figure 2

Central Air Conditioner Refrigerant Circuit

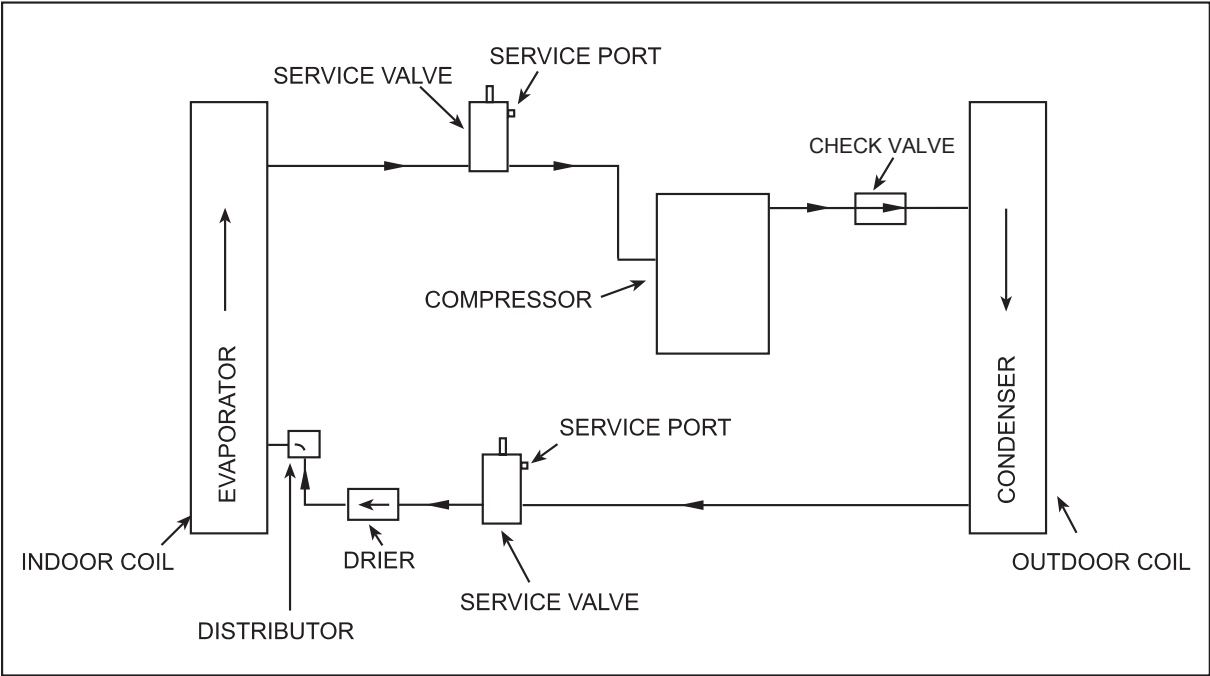

## 4.UNIT INSPECTION

This product has been inspected at the factory and released to the transportation agency without known damage. Inspect exterior of carton for evidence of rough handling in shipment. Unpack carefully. If damage is found, report immediately to the transportation agency.

## 5.EQUIPMENT PROTECTION FROM ENVIRONMENT

The metal parts of the unit may be subject to rust or corrosion in adverse environmental conditions. This oxidation could shorten the unit life. Salt spray or mist in seacoast areas, sulphur or chlorine from lawn watering systems and various chemical contaminants from industries such as paper mills and petroleum refineries are especially corrosive.

If the unit is to be installed in an area where contaminants are likely to be a problem, special attention should be given to the equipment location and exposure.

- Avoid having lawn sprinkler heads spray directly on the unit cabinet.
- In coastal areas, locate the unit on the side of the building away from the waterfront.
- Shielding provided by fence or shrubs may give some protection.

Regular maintenance will reduce the buildup of contaminants and help to protect the unit's finish.

**! WARNING -** Disconnect all electrical power to the unit before servicing. Disconnect power to both the indoor and outdoor units. **NOTE:** There may be more than one electrical disconnect switch. Failure to shut off power can cause electrical shock resulting in personal injury or death.

- Frequent washing of the cabinet, fan blade and coil with fresh water.
- Regular cleaning and waxing of the cabinet with good automobile polish.
- A good liquid cleaner may be used several times a year to remove matter that will not wash off with water.

The best protection is frequent cleaning, maintenance and minimal exposure to contaminants.

## 6.INSTALLATION

### 6.1.GENERAL

These units are designed for outdoor installations. They can be mounted on a slab or rooftop. It is important to consult your local code authorities at the time the first installation is made.

Check following points before attempting any installation:

- Structural strength of supporting members.
- Clearances and provision for servicing.
- Power supply and wiring.
- Location for minimum noise, where operating sounds will not disturb owner or neighbors.
- Location where there is no risk of combustible gas leakage.
- Location where external water drainage cannot collect around the unit.
- Location where roof runoff water does not pour directly on the unit. Provide gutter or other shielding at roof level. Don't locate unit in an area where excessive snow drifting may occur or accumulate.

Provide a level concrete slab. To prevent transmission of noise or vibration, slab should not be connected to building structure. Some sort of sound-absorbing material should be placed between the condenser and the slab. A good material to use is rubber and cork pad.

For rooftop application, make sure the building construction can support the weight and that proper consideration is given to the weather-tight integrity of the roof. The condensing unit contains moving parts and can vibrate. Therefore, sound is also a consideration in rooftop applications.

**! WARNING** - Install the unit securely in a place that can bear the weight of the unit. When installed in an insufficiently strong place, the unit could fall causing injury.

## 6.2.UNIT CLEARANCES

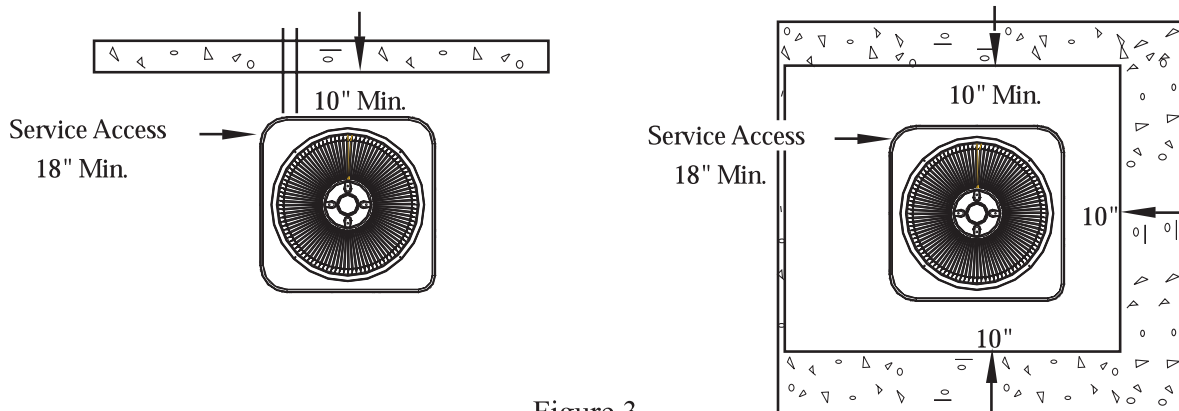

Figure 3

The minimum clearances for the unit are illustrated in Figure 3. Condenser air enters from three sides. Air discharges upward from the top of the unit. Refrigerant tube and electrical connections are made from the service access area. The most common application will find the unit best located about 10" from back wall with connection side facing the wall. This application minimizes exposed tubing and wiring, minimizing the space for youngsters to run around the unit with subsequent damage to the tubing or wiring.

In more confined application spaces, such as corners provide a minimum of 10" clearance on all air inlet sides. For service access to the compressor and control box, allow 18" minimum clearance. Ensure top is unobstructed. If units are to be located under an overhang, there should be a minimum of 36" clearance and provision made to deflect the warm discharge air out from the overhang.

In order to have an unrestricted air flow, owners should be advised to avoid lawn mower discharge toward the unit depositing debris on the fin coil surface reducing the unit efficiency.

## 6.3.REFRIGERANT PIPING

The refrigerant piping is very important as it affects the proper operation and efficiency of the air conditioning system. Note the following guidelines:

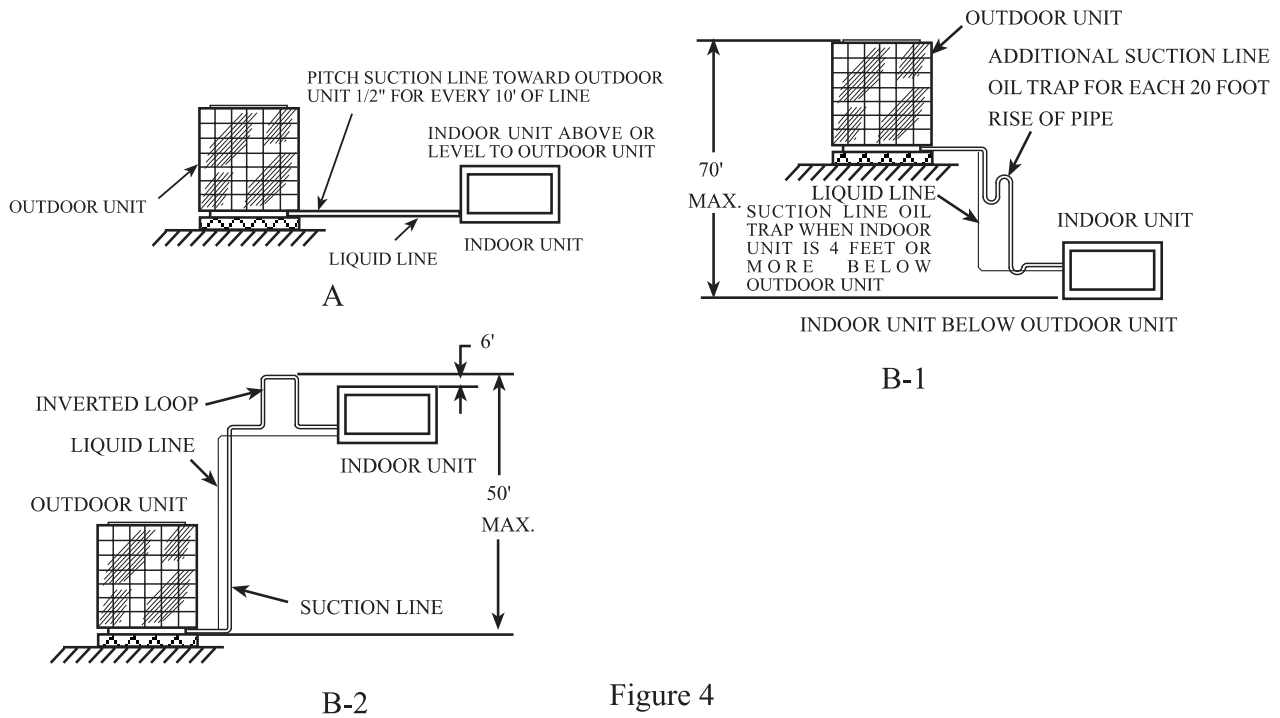

Figure 4

- Only refrigeration-grade copper piping (dehydrated and sealed) should be used. Take extreme care to keep the refrigerant tubing clean and dry prior to and during installation. If in doubt, blow out the tubing with dry nitrogen to remove any chips or debris before connection. Always keep tubing sealed until it is in place and the connections are to be made.  
Refrigerant piping should be as short as possible, with a minimum of elbows or bends, to avoid capacity loss and increased operating costs.
- Refrigerant lines must be adequately supported. If metal strapping is used to secure the tubing, do not allow the strapping to directly contact the tubing. Use a closed cell insulation to separate the strapping from the tubing.
- Do not kink or twist the tubing.
- Refrigerant piping should not be installed in a cement slab, as this limits access to the refrigerant should a leak be suspected.
- To ensure good oil return to the compressor, it is important to pitch the horizontal suction line toward the compressor, approximately 1/2" for every 10' of line.

### Line Insulation

Suction line requires insulation in order to prevent condensation from forming on the piping and to prevent heat gain caused by surrounding air. Generally 3/8" wall thickness of Armflex or equivalent is satisfactory. In severe application (hot, high humidity areas) greater thickness may be required. Apply the line insulation by sliding it on the sealed tubing before cutting and making connections.

Liquid line does not necessarily need insulation, however, if they are exposed to high ambient temperatures (i.e. kitchen, boiler rooms, hot attics & rooftop surface), then, they should be insulated. Make sure to use the proper size tubing for the liquid line to prevent liquid refrigerant flashing to a vapor within the liquid line.

Do not allow the vapor line and liquid line to touch together. This would cause an undesirable heat transfer resulting in capacity loss and increased power consumption.



## Refrigerant Line Sizing

Check the following table (Table 3) for correct suction and liquid line sizes for any combination of the unit size and the maximum refrigerant line length.

Unit Size (Ton)	Refrigerant Line Length (Ft)						Seer
	Up to 25		26-50		51-75		
	Suction	Liquid	Suction	Liquid	Suction	Liquid	
1.5	3/4	3/8	3/4	3/8	3/4	3/8	13
2.0	3/4	3/8	3/4	3/8	3/4	3/8	13
2.5	3/4	3/8	3/4	3/8	7/8	3/8	13
3.0	3/4	3/8	3/4	3/8	7/8	3/8	13
3.5	7/8	3/8	7/8	3/8	1 1/8	3/8	13
4.0	7/8	3/8	7/8	3/8	1 1/8	1/2	13
5.0	7/8	3/8	1 1/8	3/8	1 1/8	1/2	13

**Table 3: Refrigerant Line Sizing**

The factory charge is sufficient for 15 feet of standard liquid line. For longer or shorter liquid line lengths, adjust the charge as follows:

- 1/4" Line +/- 0.3 oz. Per foot
- 5/16" Line +/- 0.4 oz. Per foot
- 3/8" Line +/- 0.6 oz. Per foot
- 1/2" Line +/- 1.2 oz. Per foot

### Vertical Separation between Indoor and Outdoor Units

Maximum allowable vertical separations between indoor and outdoor units are illustrated in **Figure 4-B-1 and Figure 4-B-2**. It's 70' when the indoor unit is below the outdoor unit (Figure 4-B-1), and 50' when the indoor unit is above the outdoor unit (Figure 4-B-2).

To ensure good oil return to the compressor when the indoor unit is below the outdoor unit, suction line oil trap should be used as illustrated in **Figure 4-B-1**.

### Tubing Connections

**! CAUTION** - Use extreme caution in removing the caps from the suction and liquid line fittings, as there is pressure present. A fitting is on the liquid line to remove pressure.

**! CAUTION** - Condensing units are charged with refrigerant. Condensing unit liquid and suction valves are closed to contain the charge within the unit. Do not force the valve stem against the retaining ring. If the valve stem is backed out past the retaining ring, system pressure could force the valve stem out of the valve body and possibly cause personal injury.

**! CAUTION** - The piston is in the accessory bag. Don't forget to take it out and put into the indoor liquid pipe orifice.

Instructions on the field tubing connections and valve opening procedure are as follow:

1. Tubing should be cut square. Make sure it is round and free of burrs at the connecting ends.  
Clean the tubing to prevent contamination from entering the system.
2. Make sure that both refrigerant stop valves at the outdoor unit are closed.
3. Push the tubing into the fitting until it stops. This prevents flux from getting into the system.
4. Remove the cap and Schrader valve core from the service port to protect the valve seals.
5. Wrap a wet rag around the valve stub before brazing.
6. Braze the joints of interconnecting tubing. Flow dry nitrogen into the shutoff valve port and through the tubing while brazing.
7. After brazing quench with a wet rag to cool the joint. Reinstall the Schrader core in the valve, if removed for brazing.
8. Pressurize the lines to 150 psi maximum with dry nitrogen. Check for leaks at all joints with liquid detergent. If a leak is found, repair it after removing the nitrogen. Repeat the process and re-check.
9. Do not purge the lines with refrigerant. Evacuate the lines and indoor coil.

## Refrigerant Metering Devices

Replace the existing indoor unit fixed orifice with the orifice supplied with the outdoor unit.

See table 4 for the fixed orifice size for each unit.

Table 4

outdoor model	indoor model	orifice size
HC18D2VAE	HB2400VD2M20	049
HC24D2VAE	HB2400VD2M20	057
HC30D2VAE	HB3600VD2M20	065
HC36D2VAE	HB3600VD2M20	068
HC42D2VAE	HB4800VD2M22	074
HC48D1VAE	HB4800VD2M22	081
HC60D1VAE	HB6000VD2M22	091

## Evacuation

All new installations must be evacuated to a deep vacuum in order that all noncondensable gases and moisture are removed prior to charging the system. Air in a system causes high condensing pressure, which increases power consumption and reduces performance. The presence of moisture in a system can render it inoperable in a very short time. Proper evacuation assures a dry, uncontaminated system. Here is the recommended evacuation procedure:

1. Connect vacuum pump to both liquid and suction valve service ports.
2. Evacuate the interconnecting tubing and indoor coil to 500 microns or less for a minimum of 30 minutes. Close the valve to the vacuum pump and wait 15 minutes. Vacuum should not rise above 800 microns. If unable to obtain 500 microns, or vacuum rises above 800 microns over 15 minutes period, discontinue evacuation, pressurize and check for leaks. Repair any leaks found and repeat the step 2.
3. Close valve to the vacuum pump and stop pump.
4. When sure of a tight, well evacuated system, charge with refrigerant.

## Charging the System

(For systems with capillary tube or fixed orifice metering device)

Before checking the system charge, make sure that the outdoor unit and indoor coil must be an approved match per the unit specification. The indoor conditions should be within 2°F of the desired comfort conditions.

**! WARNING - Do not vent refrigerant to the atmosphere!** It is a violation of federal law to do so. If the refrigerant needs to be removed from a system to correct the charge inside, always use a recovery or recycling device.

**! WARNING - To prevent personal injury, wear safety glasses and gloves when handling refrigerant.**

1. Fully open both shutoff valves.
2. Connect service gage manifold to the valve service ports, being sure to evacuate lines.
3. Startup the system (Refer to the Section 7 - "System Startup"). Run system at least 10 minutes to allow pressure to stabilize.
4. Temporarily install thermometer on suction (large) line near condensing unit. Be sure of good contact between thermometer and line. Wrap thermometer with insulating material to assure accurate reading.
5. Refer to Table 5 for proper system superheat. Add charge to lower superheat. Remove charge to raise superheat.  
Carefully remove gage lines.

System Superheat					
Ambient Temperature At Condenser Inlet (°F)	Return Air Temperature (°F)				
	65	70	75	80	85
60	17	25	30	33	37
65	13	19	26	32	35
70	5	14	20	28	32
75	5	10	17	25	29
80		5	12	21	26
85		5	10	17	20
90			7	12	18
95			5	5	5
100				5	5
115				5	5

Table 5: System charging table by superheat

## 6.4.ELECTRICAL WIRING

### ! WARNING -

- A means of strain relief must be installed to this appliance at the electrical service entrance. Make sure that interconnecting wires between indoor and outdoor units meet the standards, codes and regulations. Incomplete connection or fixing of the wire could result in a fire.
- Perform electrical work according to the installation manual and be sure to use an exclusive circuit. If the capacity of the power circuit is insufficient or there is incomplete electrical work, it could result in a fire or an electric shock.
- Ground the unit. Do not connect the ground to a gas pipe, water pipe, lighting rod or telephone ground. Defective grounding could cause an electric shock.

Electrical installation will consists of power supply wiring to the condensing unit and control wiring between thermostat, indoor unit and the condensing unit. All wiring must be in accordance with National Electrical Code and/or local ordinances that may apply.

(See unit wiring diagram furnished with this instruction).

Note: Some states need the power supply wiring within special tube be careful to use a waterproof tube when installing the outdoor unit power supply wiring.(See the Figure 5)



Figure 5-1



Figure 5-2

The condensing unit rating plate and the tables of "Physical and Electrical Specifications / Outdoor Units" (Table 1 and 2) provide pertinent data necessary for the selection of proper size electrical service and over-current protection devices.

Table 6 provides data on the minimum copper wire size as a function of supply wire length and circuit ampacity.

Copper Wire Size - AWG (1% Voltage Drop)				
Supply Circuit Ampacity	Supply Wire Length - Ft			
	50	100	150	200
15	14	10	8	6
20	12	8	6	4
25	10	8	6	4
30	10	6	4	4
35	8	6	4	3
40	8	6	4	2
45	6	4	3	2
50	6	4	3	1

Table 6: Minimum Wire Size Based on N.E.C. for 60 C Type Copper Conductors Below 100 Ampacity.

The owner should be made familiar with the location of the over-current protection, the proper size for this application and the proper procedure for disconnecting power service to the unit.

The condensing unit control wiring requires a 24 Volt minimum, 25 VA service from the indoor transformer as shown on the wiring diagram.

## 7.SYSTEM STARTUP

- 1.Turn thermostat to "OFF", turn on power supply at disconnect switch.
  - 2.Turn temperature setting as high as it will go.
  - 3.Turn fan switch to "ON". Indoor blower should run. Be sure it is running in the right direction.
  - 4.Turn fan switch to "AUTO". Turn system switch to "COOL" and turn temperature setting below room temperature. Unit should run in cooling mode.
  - 5.Check to see if compressor and outdoor fan are running correctly?
  - 6.Check the refrigerant charge (see Instructions under "Charging the System").
  - 7.Replace service port caps. Service port cores are for system access only and will leak if not tightly capped.
  - 8.Check unit for tubing and sheet metal rattles.
  - 9.Instruct the owner on operation and maintenance.
- Leave this "Installation and Operating Manual" and the "Use and Care Manual" with owner.

## 8.OPERATION

Most single phase units are operated without start relay or start capacitor. Such systems should be off for a minimum of 5 minutes before restarting to allow equalization of pressures. The thermostat should not be moved to cycle unit without waiting 5 minutes. To do so may cause the compressor to stop on an automatic open overload device or blow a fuse. Poor electrical service can cause nuisance tripping in overloads or blow fuses.

The compressor has an internal overload protector. Under some conditions, it can take up to 2 hours for this overload to reset. Make sure overload has had time to reset before condemning the compressor.

## 9.MISCELLANEOUS

### 9.1. Replacement Parts

Contact your local distributor for a complete parts list.

### 9.2. Troubleshooting Guide

Refer to the troubleshooting guide (Table 6) included in this manual.

### 9.3. Wiring Diagram

Refer to the appropriate wiring diagram included in this manual.(P14)

## Troubleshooting Guide

**! WARNING** - Disconnect all electrical power to the unit before servicing. Disconnect power to both the indoor and outdoor units. **NOTE:** There may be more than one electrical disconnect switch. Failure to shut off power can cause electrical shock resulting in personal injury or death.

**Table 6 Troubleshooting guide**

Symptom	Possible Cause	Remedy
No cooling	Power off or loose electrical connection	Make sure main switch is ON. Check and tighten all connections.
	Incorrect thermostat setting	Set thermostat correctly
	Defective contactor	Check for 24V at contactor coil.
	Open circuit breaker or blown fuses	Reset or replace
	Defective transformer	Check wiring - Replace it.
	Interconnecting low voltage wiring damage	Replace thermostat wiring
Insufficient Cooling	Dirty filters	Clean & replace
	Indoor air blockage	Check supply registers and return grills for blockage.
	Blocked outdoor coil	Clear away leaves and other debris
	Improperly sized unit	Recalculate load
	Improper airflow	Check - should be 400CFM/Ton
	Incorrect refrigerant charge	Charge correctly per instruction.
	Air, non-condensibles or moisture in system	Recover refrigerant, evacuate & recharge, add filter drier
	Incorrect voltage	At compressor terminals, voltage must be within 10% of rating plate volts when unit is running.
Water on floor or in furnace	Blocked condensate drain and "P" trap	Remove blockage
Condenser fan runs, compressor doesn't	Run or start capacitor defective	Replace
	Loose connection	Check and tighten all connections.
	Compressor stuck, grounded or open	Wait for 2 hours for overload to reset.
	motor winding, open internal overload	Replace compressor if still open.
	Low voltage condition	At compressor terminals, voltage must be within 10% of rating plate volts when unit is running.
	Low voltage condition	Add start kit components
Compressor short-cycling	Incorrect voltage	At compressor terminals, voltage must be within 10% of rating plate volts when unit is running.
	Defective overload protector	Replace - check for correct voltage
	Refrigerant undercharge	Add refrigerant
Register sweat	Low evaporator airflow	Increase blower speed or reduce restriction - replace air filter
High head - Low vapor pressures	Restriction in liquid line, metering device or filter drier	Replace defective components
	Flowrator piston size too small	Change to correct size piston
	Incorrect capillary tubes	Change coil assembly
	Blocked outdoor coil	Clear away leaves and other debris
High head - High or normal vapor pressures	Refrigerant overcharge	Correct system charge
	Condenser fan not running	Repair or replace
	Air, non-condensibles or moisture in system	Recover refrigerant, evacuate & recharge, add filter drier
Low head - High vapor pressures	Flowrator piston size too large	Change to correct size piston
	Defective compressor valves	Replace compressor
Low vapor - cool compressor - iced evaporator coil	Incorrect capillary tubes	Replace coil assembly
	Low evaporator airflow	Increase blower speed or reduce restriction - replace air filter
	Operating below 65 F outdoors	Add low ambient kit
	Moisture in the system	Recover refrigerant, evacuate & recharge, add filter drier
High vapor pressure	Excessive load	Recheck load calculation
	Defective compressor	Replace
Fluctuating head and vapor pressures	Air or non-condensibles in system	Recover refrigerant, evacuate & recharge.
Pulsing noise at metering device or liquid line	Air or non-condensibles in system	Recover refrigerant, evacuate & recharge

# Air Conditioner Wiring Diagram

0010526552

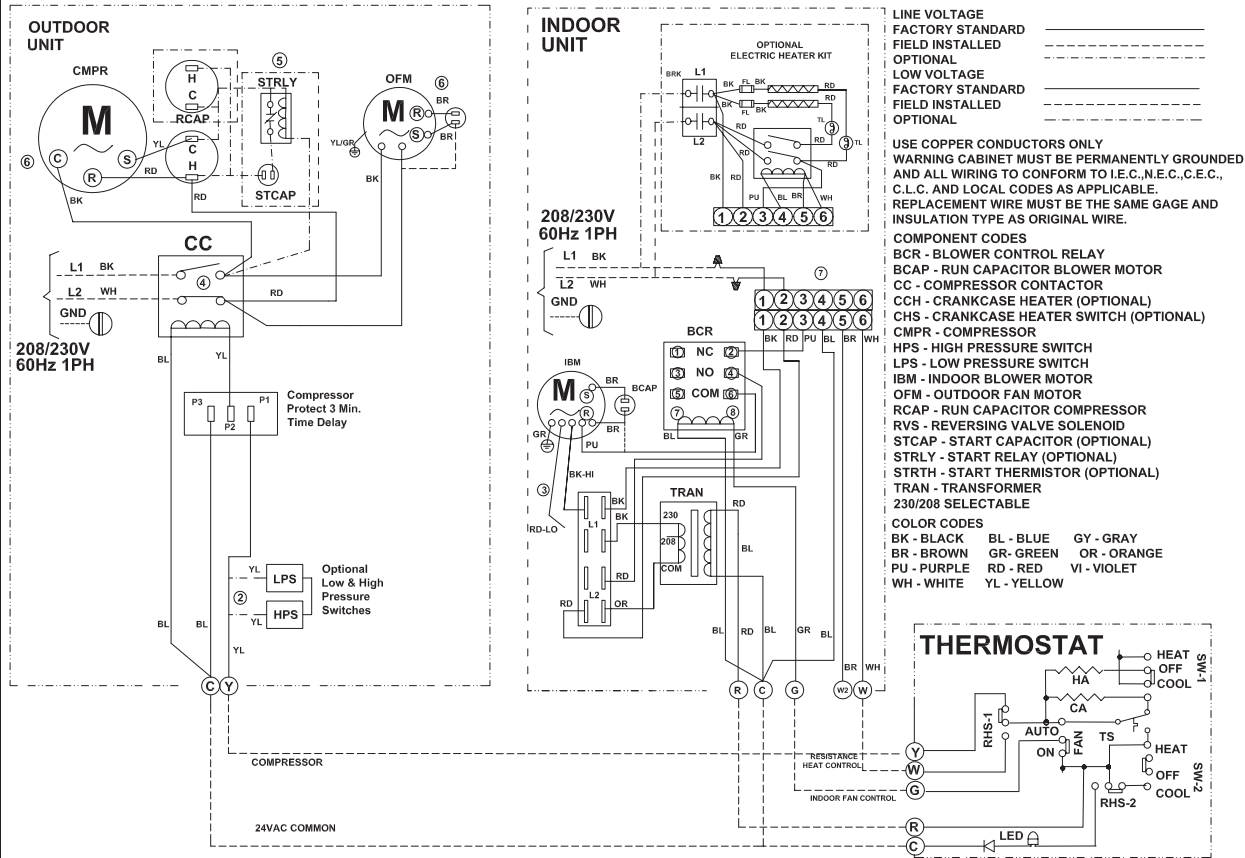

- 1) Confirm system selection. Optional components may be field or factory installed.
- 2) If LPS and/or HPS not installed or removed, a jumper wire must be present across circuit for system to operate.
- 3) For proper system operation, consult indoor unit and outdoor unit installation instructions to confirm system match up and blower speed selection.
- 4) Alternate double pole contactor used on some systems.
- 5) Only one start assist method to be used at a time, consult outdoor unit installation instructions for application information. Use only factory approved accessories.
- 6) Optional OFM components may connect capacitor common and motor common, for reciprocating compressor there may have crankcase heater consult outdoor unit installation instructions for details. Select the running capacitor (one or dual) and connect. If IFM or OFM only have one capacitor wire, connect Com wire to capacitor.
- 7) Indoor unit shipped without optional electric heater kit. To install optional heater kit, remove power pig tail up to 9 pin plug. Install heater kit and connect with mating 9 pin plug. Run system power connections directly to electric heater kit power terminals. Consult heater kit installation instructions for complete details.









