

# Installation & Operation Manual

## Air Handler

13 SEER    2 3 4 5 Ton

### WARNING

WHEN THIS APPLIANCE IS INSTALLED IN AN ENCLOSED AREA, SUCH AS A GARAGE OR UTILITY ROOM, WITH ANY CARBON MONOXIDE PRODUCING DEVICES (i.e. AUTOMOBILE, SPACE HEATER, WATER HEATER, ETC.) INSURE THAT THE ENCLOSED AREA IS PROPERLY VENTILATED.

### WARNING

CARBON MONOXIDE (REFERRED TO AS CO) CAN CAUSE PERSONAL INJURY OR DEATH

### WARNING

FAILURE TO FOLLOW THESE INSTRUCTIONS, LOCAL CODES OR NATIONAL CODES MAY CAUSE FIRE, EXPLOSION, ELECTRICAL SHOCK, PERSONAL INJURY OR PROPERTY DAMAGE.

FOLLOW ALL LOCAL CODES. IN THE ABSENCE OF LOCAL CODES REFER TO :

**NATIONAL ELECTRICAL CODE NFPA 70**

**NFPA 90A & 90B**

**UNIFORM MECHANICAL CODE**

READ THESE INSTRUCTIONS COMPLETELY BEFORE ATTEMPTING TO INSTALL OR SERVICE THIS APPLIANCE.

ONLY FACTORY AUTHORIZED KITS OR ACCESSORIES SHOULD BE USED WHEN INSTALLING OR MODIFYING THIS APPLIANCE, UNLESS OTHERWISE NOTED IN THESE INSTRUCTIONS.

SOME LOCALITIES MAY REQUIRE THE INSTALLER/SERVICER TO BE LICENSED. IF IN DOUBT CONTACT YOUR LOCAL AUTHORITIES.

These instructions should be retained and kept adjacent to the unit for future reference.

MODEL # HB \_\_\_\_\_ M20    HB \_\_\_\_\_ M22

MODEL # HB \_\_\_\_\_ V20    HB \_\_\_\_\_ V22

INSTALLATION DATE \_\_\_\_\_

The information contained in this booklet is subject to change without notice.

No. 0010572323

G

# INDEX

TOPIC	PAGE
General — — — — —	2
Physical dimensions — — — — —	3
Replacement Parts Source — — — — —	6
Installation Requirements — — — — —	6
Air Flow Orientation — — — — —	7
Horizontal Left-Hand Instructions — — — — —	8
Refrigerant Tubing — — — — —	9
Condensate Removal — — — — —	10
Electrical Connections — — — — —	10
Thermostat Wiring — — — — —	11
Orifice Change — — — — —	12
Circulating Air Duct — — — — —	14
Blower Performance — — — — —	14
Start-up — — — — —	15
Regular Maintenance — — — — —	15
Model Number Explanation — — — — —	16

The United States Environmental Protection Agency (EPA) has issued various regulations regarding the introduction and disposal of refrigerants introduced into this unit. Failure to follow these regulations may harm the environment and can lead to the imposition of substantial fines. These regulations may vary due to the passage of new laws, it is recommended that any work on this unit be done so by a certified technician. Should questions arise contact the local EPA office.

**THIS APPLIANCE IS NOT APPROVED FOR OUTDOOR INSTALLATION  
THIS APPLIANCE IS NOT TO BE USED AS A CONSTRUCTION HEATER**

## GENERAL

This appliance was designed certified and must be installed in accordance with published codes. In the absence of local codes please refer to the following codes:

**NFPA 90A NFPA 90B  
National Electrical Code NFPA 70  
Uniform Mechanical Code**

Prior to shipment, this appliance was tested and inspected for damage at the factory. Unpack carefully and if damage is found, report it immediately to the transportation company.

This appliance is approved for installation in alcoves, basements, attics or crawlway, and is designed for connection to air distribution ductwork.

**PHYSICAL DIMENSIONS of 2 Ton**

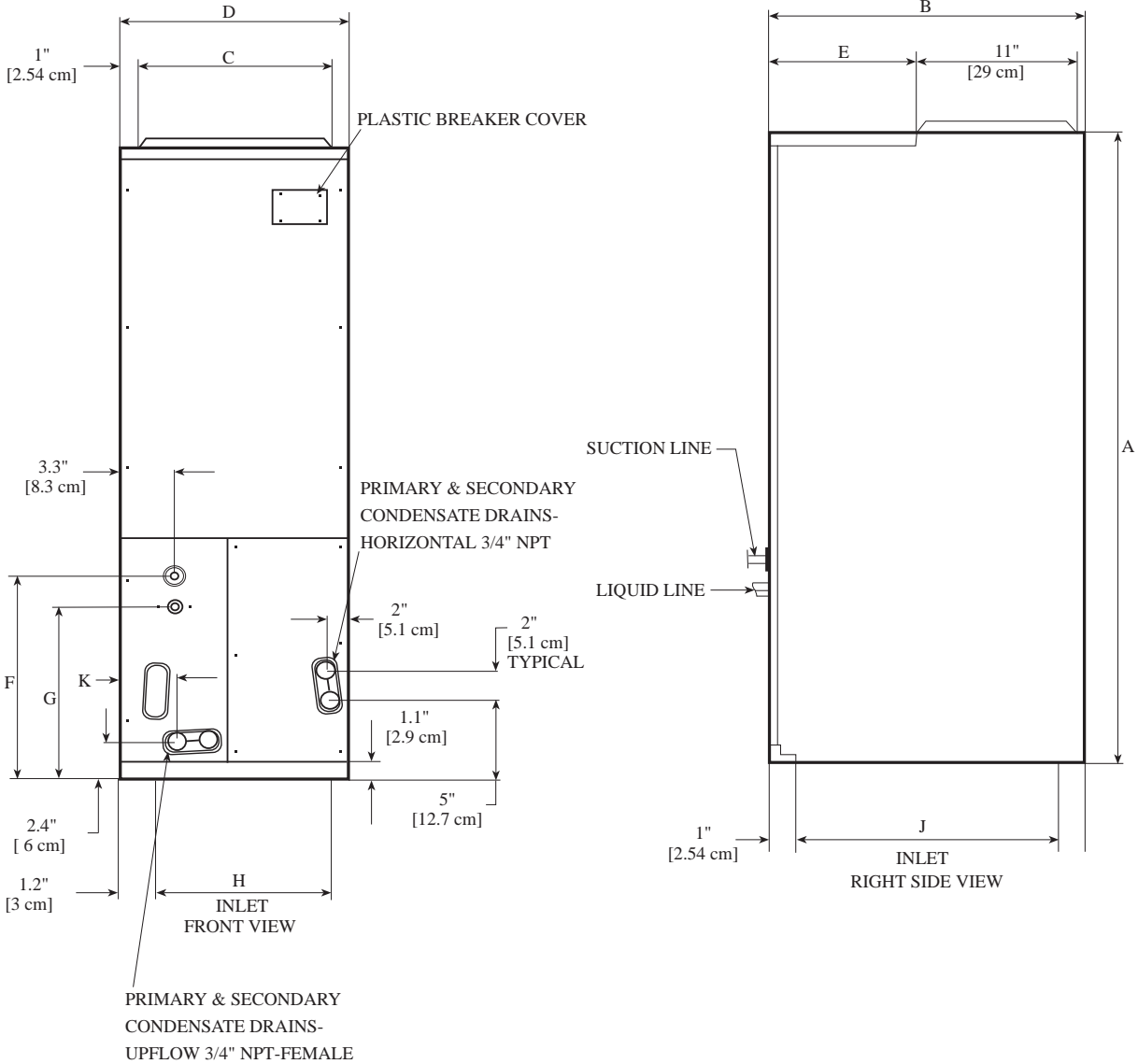

A	B	C	D	E	F	G	H	J	K
46.7	22	18.3	19.7	10	14.5	11.9	17.1	19.8	3.4
[118.7cm]	[55.9cm]	[46.4cm]	[50.0cm]	[25.4cm]	[36.8cm]	[30.3cm]	[43.5cm]	[50.3cm]	[8.6cm]

# PHYSICAL DIMENSIONS of 3 Ton

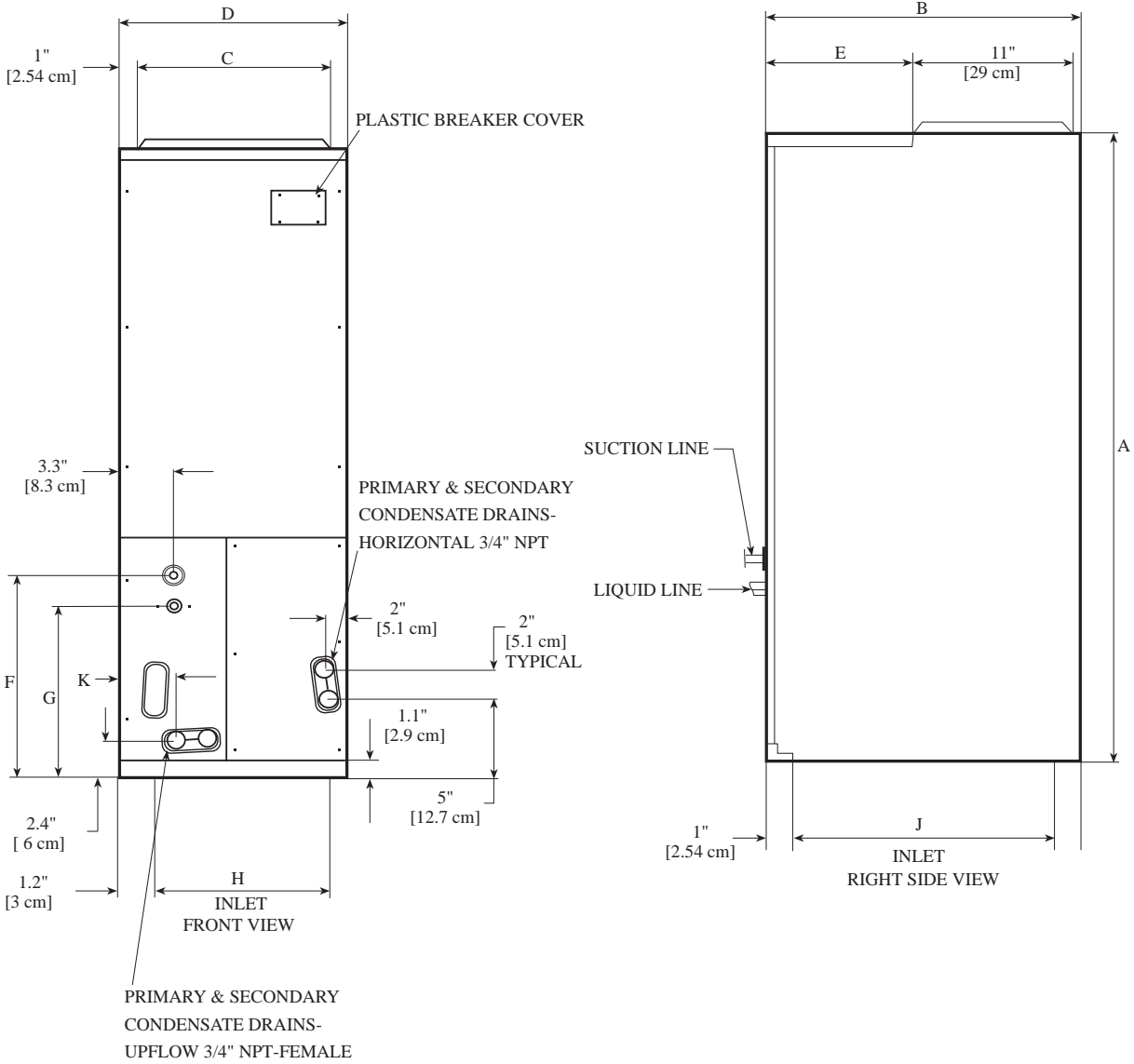

A	B	C	D	E	F	G	H	J	K
46.7	22	18.3	19.7	10	14.5	11.9	17.1	19.8	3.4
[118.7cm]	[55.9cm]	[46.4cm]	[50.0cm]	[25.4cm]	[36.8cm]	[30.3cm]	[43.5cm]	[50.3cm]	[8.6cm]

# PHYSICAL DIMENSIONS of 4\*5 Ton

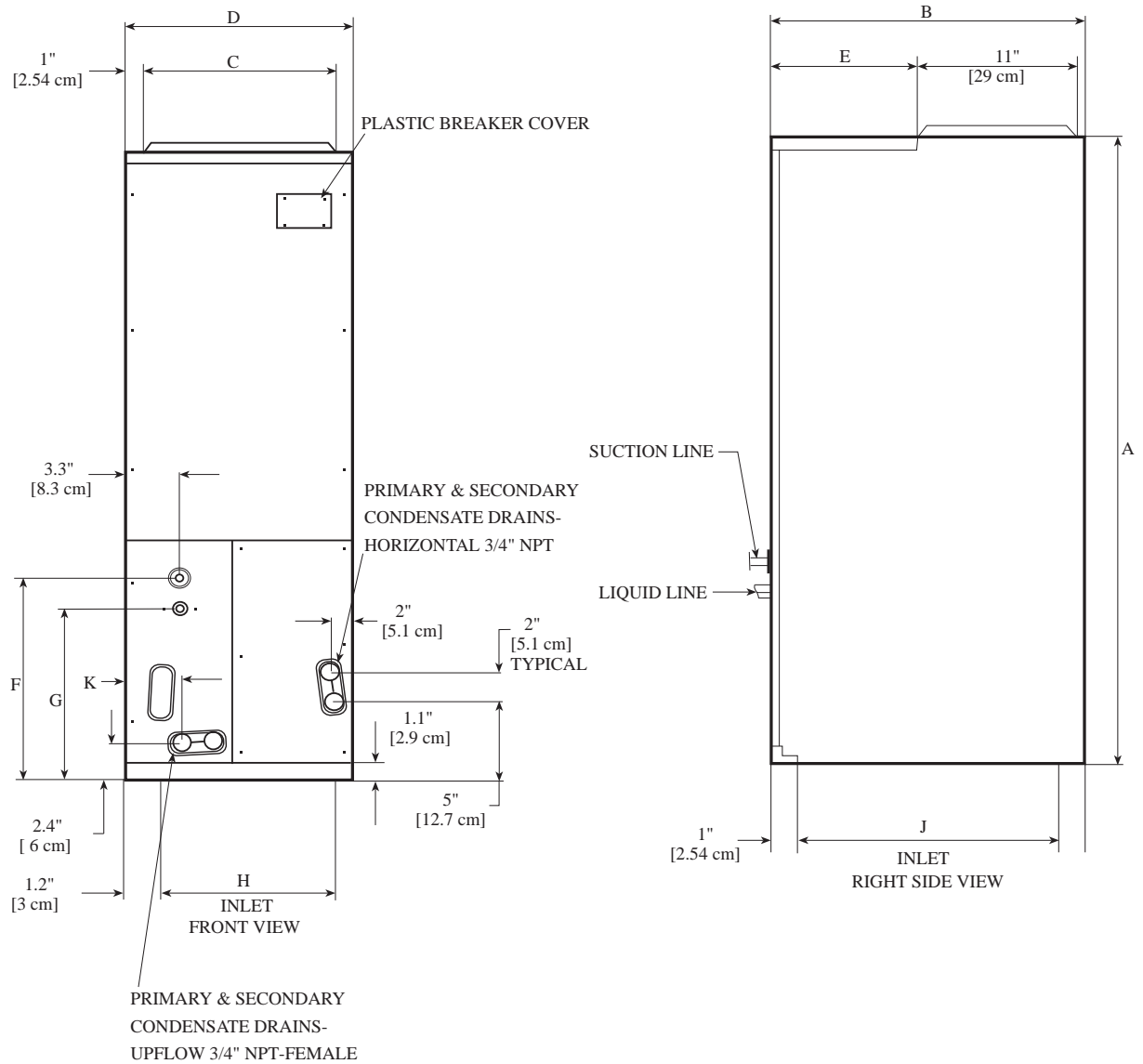

A	B	C	D	E	F	G	H	J	K
46.7	22	18.3	19.7	10	14.5	11.9	17.1	19.8	3.4
[118.7cm]	[55.9cm]	[46.4cm]	[50.0cm]	[25.4cm]	[36.8cm]	[30.3cm]	[43.5cm]	[50.3cm]	[8.6cm]

## **REPLACEMENT PARTS SOURCE**

Replacement parts are available through local distributors. When ordering replacement parts, give the COMPLETE model and serial numbers shown on the rating plate.

## **INSTALLATION REQUIREMENTS**

Before installing this appliance insure that it is properly sized and adequate power is available.

This appliance can be installed in the vertical or right horizontal position without modification. The horizontal left and downflow positions require product modification.

This product is designed for zero inch (0") clearance; however, adequate access for service or replacement must be considered without removing permanent structure. This unit can be installed on a platform when deemed necessary.

In an attic installation a secondary drain pan must be provided by the installer and placed under the entire unit with a separate drain line properly sloped and terminated in an area visible to the owner. This secondary drain pan is required in the event that there is a leak or main drain blockage. Closed cell insulation should be applied to the drain lines in unconditioned spaces where sweating may occur.

Appliances installed in garages, ware houses or other areas where they may be subjected to mechanical damage must be suitably guarded against such damage by installing behind protective barriers, being elevated or located out of the normal path of vehicles. When installed on a base, the base must also be protected by similar means.

Heating and cooling equipment located in garages, which may generate a glow, spark or flame capable of igniting flammable vapors, must be installed with the ignition source at least 18" above the floor level.

When more than one appliance is installed in a building, permanently identify the unit as to the area or space serviced by that appliance.

## AIR FLOW ORIENTATION

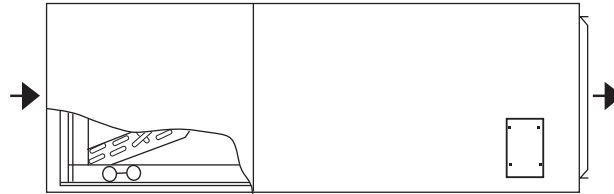

\*Horizontal Right Discharge  
Tube and Drain conn. front

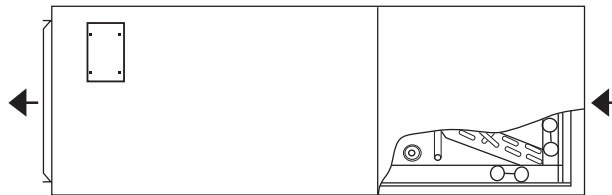

Horizontal Left Discharge  
Tube and Drain conn. front  
(see page 6)

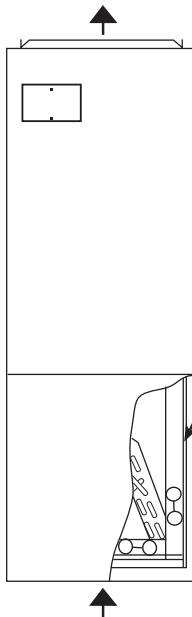

\*Upflow Discharge

**Important:**

Remove the horizontal pan when unit is installed in unconditioned i.e. (Garage, Attic ) application, or downflow applications, and install insulation kit on vertical ( donut shape ) drain pan.

\*Air Handler is factory ready for Upflow & Horizontal Right Discharge Application for 3\*4\*5 as shown.

\*Air Handler is factory ready for Upflow & Horizontal Left Discharge Application for 2 as shown.

## HORIZONTAL LEFT-HAND INSTRUCTIONS

Important: Read instructions below carefully.

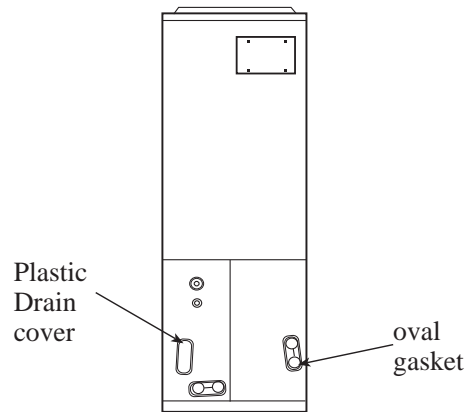

**Fig.1**

**WARNING:** If incorrect knockouts are removed, flooding will occur.

- 5) Reinstall in the Airhandler, the "A" coil pan assembly with the horizontal drain pan on the left-hand side.

*Note:* Push the assembly completely to the rear of the cavity and assure it slips into channel bracket at the rear of the cavity.

- 6) Replace the J-shape metal bracket or brackets on the vertical drain pan and place the plastic oval gasket on horizontal drain pan. Reinstall access panels and flowrator making sure not to over torque screws. Snap in the drain cover on the right lower service panel.
- 7) The Airhandler can now be placed in its left horizontal position as shown in Fig.2. The Airhandler must be leveled and then pitched 1/4" toward drain side. *Important:* Drain pan must be tested for proper drainage by pouring water into the pan. Traps must be installed on the primary drain and on the secondary drain if used.
- 8) In all cooling applications, a secondary drain pan must be provided by the installer and placed under the entire unit with a separate drain line properly sloped and terminated in an area visible to the user.

- 9) **WARNING:** The "A" coil contains 150 p.s.i.g. of air pressure.

Before setting up flowrator assembly for field brazing see page 12 or read the *Warning label* on the lower access panel.

- 10) Failure to follow this installation requirements will cancel product warranty.

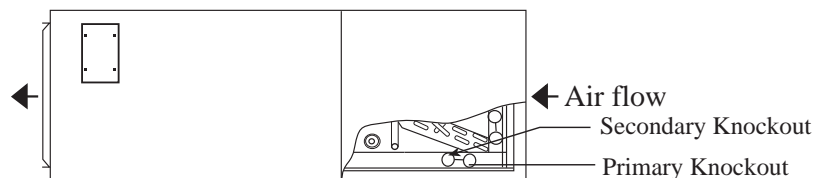

**Fig.2**



## REFRIGERANT TUBING

Refrigerant tubing should be installed as to avoid undue stress. They must be supported or routed to avoid strain or vibration. To avoid damage that can be caused by condensate, insulate the suction tube with a closed cell insulation with the seams sealed. The insulation should terminate at the tubing entrance to the air handler. Do not reduce the recommended tubing size.

## CONDENSATE REMOVAL

**THIS APPLIANCE EMPLOYS A DRAW-THROUGH COIL, THEREFORE A TRAP MUST BE INSTALLED IN THE DRAIN LINE(S) TO ALLOW FOR PROPER CONDENSATE DISPOSAL.**

The condensate trap must not be the "running" type, or "R" type. A "P" trap is required. The total workable height of this trap, in inches, must exceed the total negative pressure, in inches of water, as measured in the return duct.

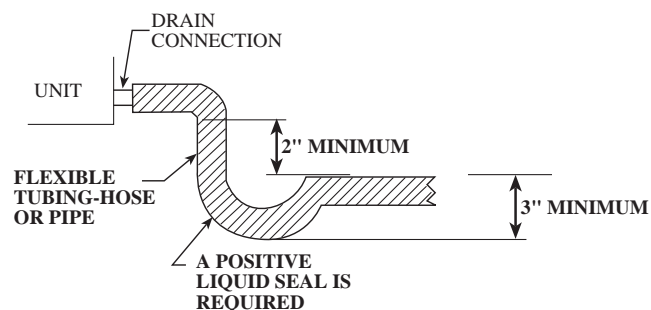

The condensate drain line must be at least 3/4 NPT, for each unit. Precautions must be used not to over tighten the adapter at the drain pan connection, this precaution will prevent damage to the plastic drain pan. A joint compound should be used to prevent leakage and act as a lubricant.

When using copper tubing as a condensate line adequate caution must be taken to prevent damage to the plastic drain pan during the soldering process. All condensate drain lines and drain traps should be adequately insulated.

The unit and the auxiliary drain pan must be adequately elevated to insure proper drainage.

Use of a condensate removal pump is permitted when necessary. This condensate pump should have provisions for shutting off the control voltage should a blocked drain occur. A trap must be installed between the unit and the condensate pump. **Important:** The evaporator coil is coated with oils that will dissolve Styrofoam and certain types of plastics. Therefore a removal pump or float switch must not contain any of these materials.

**NOTE: AFTER INSTALLATION AND POSITIONING THE UNIT , THE DRAIN PAN BEING USED SHOULD BE TESTED BY FILLING IT WITH WATER TO ENSURE PROPER DRAINAGE AND CHECK FOR LEAKS.**

## ELECTRICAL CONNECTIONS

The required electrical power supply information is located on the series and rating plate on the exterior of the unit. Wiring selection must be in accordance with local codes, or in absence of local code, the National Electrical Code. A disconnect means should be installed within sight of the unit, when required by code.

Copper wire is recommended for all electrical connections.

When an optional heat kit is installed refer to the electrical requirements in that kit.

The wiring diagram included in the heat kit must be placed over the wiring diagram on the air handler.

All pertinent information, such as the rating plate, included in the optional heat kit must be applied to the Air Handler as indicated.

The use of copper connections are recommended inside the control box (see UL 1995, section 37.9).

Model No.	Min. running Ampacity 208/230	Max. Over-current 208/230	Blower Motor FLA	Blower Motor H.P.
2 Ton	-----	15/15	0.9	1/8
3 Ton	2.5/2.5	15/15	2.0	1/3
4 Ton	3.3/3.3	15/15	2.6	1/2
5 Ton	4.4/4.4	15/15	3.5	1/2
5 Ton -E	5.0/5.5	15/15	4.0	3/4

### WARNING

A MEANS OF STRAIN RELIEF MUST BE INSTALLED TO THIS APPLIANCE AT THE ELECTRICAL SERVICE ENTRANCE.

When an optional electric heat kit is installed refer to the electrical requirements for that kit. The ampacity and overcurrent protection shown above is **only** for "HB" air handlers installed **without** a heat kit.

# THERMOSTAT WIRING

For Thermostat Control Environment-temperature and Air Conditioning open/stop, the wiring diagram as shown diagram 1. Thermostat can be mechanical type or programmable type.

Note: Thermostat(C): COM.

(R): AC24V

(Y): COMPRESSOR

(G): FAN

(O): 4 -WAY VALUE

For detailed Thermostat, please connect corresponding terminal according to above control specification.

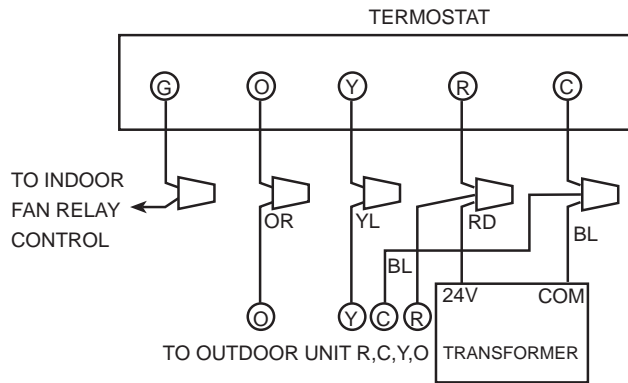

Diagram 1

For Thermostat only control Air Conditioning open/stop, hot control Environment temperature, can adopt different power switch show diagram 2. This mode is control the indoor unit & heat pump outdoor unit at the same time no air supply mode. If need select the air supply mode, switch can adopt multi-connect switch or select switch. The detailed infor see the following diagram 3.

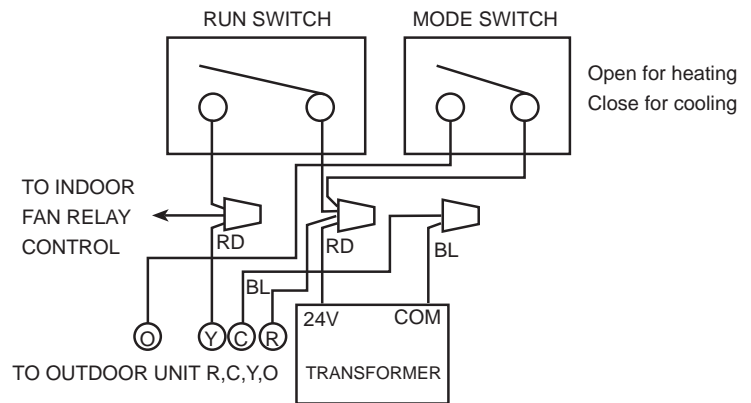

Diagram 2

Above diagram: Outdoor Unit Connection

Left: Indoor and Outdoor unit power supply Respectively Right: Indoor unit power supply.

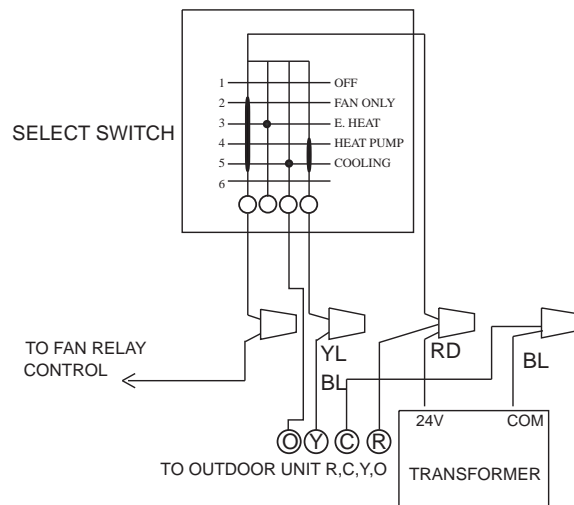

Diagram 3

For Thermostat Control Environment-temperature and Air Conditioning open/stop, the wiring diagram as shown diagram 4. Thermostat can be mechanical type or programmable type.

Note: Thermostat **(C)**: COM.

**(R)**: AC24V

**(Y)**: COMPRESSOR

**(G)**: FAN

For detailed Thermostat, please connect corresponding terminal according to above control specification.

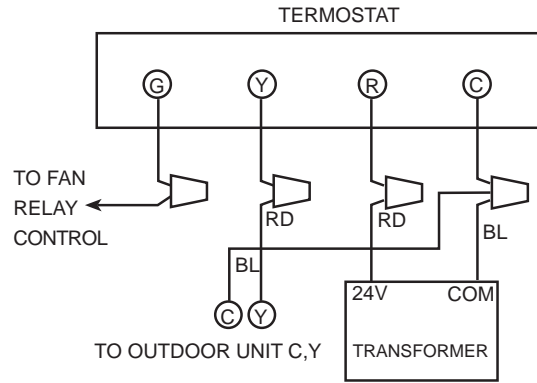

Diagram 4

For Thermostat only control Air Conditioning open/stop, hot control Environment temperature, can adopt different power switch show diagram 5. This mode is control the indoor unit & cooling only outdoor unit at the same time no air supply mode. If need select the air supply mode, switch can adopt multi-connect switch or select switch. The detailed infor see the following diagram 6.

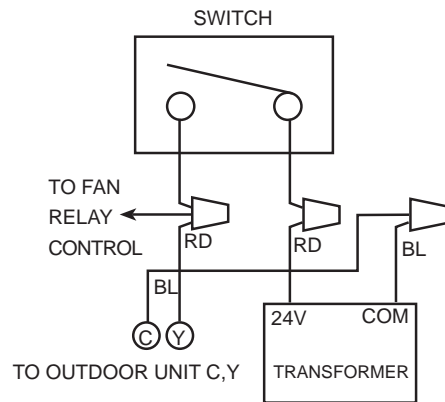

Diagram 5

Above diagram: Outdoor Unit Connection

Left: Indoor and Outdoor unit power supply Respectively Right: Indoor unit power supply.

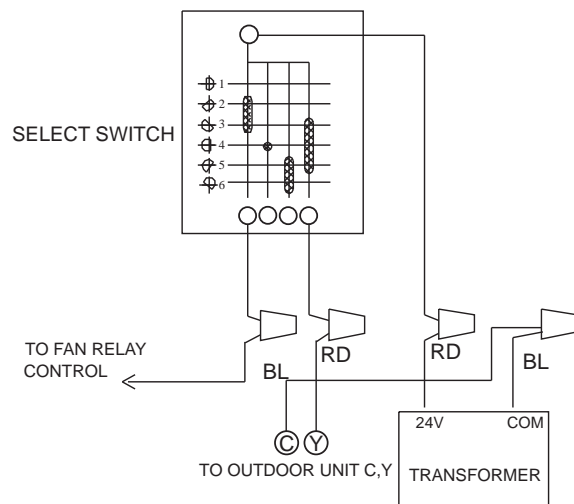

Diagram 6

## ORIFICE CHANGE

The restrictor (orifice) included in this unit match the comparable capacity of the outdoor unit. If the indoor unit is greater in capacity than the outdoor condenser, the orifice must be changed to match the outdoor unit capacity. The restrictor (orifice) should be replaced before any tubing connections are made.

### **THE CAPACITY OF THE OUTDOOR UNIT SHOULD NEVER EXCEED THE CAPACITY OF THE INDOOR UNIT.**

To replace the restrictor (orifice), follow the steps below:

#### **WARNING**

#### **THIS COIL IS SHIPPED UNDER PRESSURE. FOLLOW THESE INSTRUCTIONS TO PREVENT INJURY:**

- 1) Loosen the 13/16 nut **1TURN ONLY**. No pressure loss indicates possible leak.
- 2) Remove the nut and discard the seal cap.
- 3) Remove the check piston to **verify it is correct**. See piston kit table 1 in manual.
- 4) Use a tube cutter to remove the spin closure on the suction line.
- 5) Remove the tailpiece clamped to the exterior.
- 6) **Slide the 13/16 nut into position**. Braze tailpiece to the liquid tube.
- 7) Insert the suction line into the connection, slide the insulation and the rubber grommet at least 18" away from the braze joint.
- 8) **AFTER THE TAILPIECE HAS COOLED**, position the white Teflon seal and hand tighten the nut.
- 9) Torque the 13/16 nut to 10-30 ft/lbs. or tighten 1/6 turn.
- 10) Replace suction line grommet and insulation.

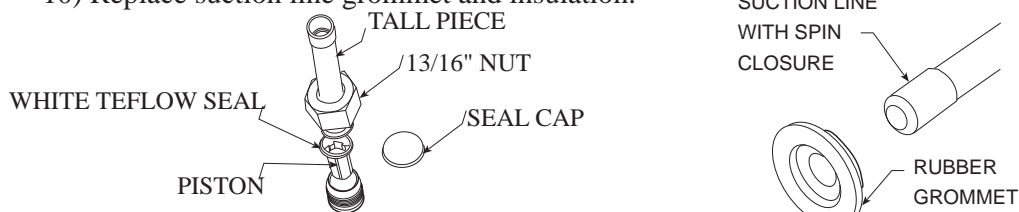

## CIRCULATING AIR DUCT

Air duct systems should be designed and installed as per local and/or national code. Refer to NFPA 90A & 90B and the National Environmental Systems Contractors Association - Manual "K".

The use of flexible duct connectors is recommended to minimize the possibility of noise transmission. These connectors must conform to U.L. standards.

Supply air ducts must be insulated and return ducts must be insulated when passing through an unconditioned space. When passing through an unconditioned space it may be necessary to install a vapor barrier to the exterior of the ducts to prevent condensation.

Seams of all supply ducts must be sealed to prevent leakage and return ducts sealed airtight to prevent infiltration.

The supply plenum should be the dimensions specified by the factory.

## BLOWER PERFORMANCE

CFM versus Static Pressure (inches of water column dry coil w/ filter) 4% reduction for wet coil.

Model	Static Pressure CFM	0.1	0.15	0.2	0.25	0.3	0.35	0.4	0.5
		2 Ton	High	900	877	856	835	816	795
Middle	630		614	599	585	571	556	536	515
3 Ton	High	-----	1240	1208	1177	1148	1121	1091	1061
	Low	-----	1125	1093	1062	1033	1006	976	946
4 Ton	High		-----	1650	1605	1560	1515	1470	1425
	Low		1480	1442	1404	1366	1328	1290	1252
5 Ton	High	-----	-----	1800	1745	1690	1635	1580	1525
	Low	-----	-----	-----	-----	-----	-----	-----	-----
5 Ton-E	High	-----	-----	1850	1795	1740	1685	1630	1575
	Low	-----	-----	-----	-----	-----	-----	-----	-----

The air delivery can be varied by changing the blower speeds. This can allow for differences encountered in installations.

The CFM can be checked by the following method;

(The optional Heat Kit must be installed to continue with this procedure.)

- 1) All access panels must be in place.
- 2) Start the unit in the heat mode.
- 3) Measure the return air temperature.
- 4) Measure the supply temperature. This measurement should be done in various locations to obtain an average.
- 5) Subtract the return temperature from the supply temperature. This is referred to as the temperature rise.
- 6) Measure the actual supply voltage and actual amperage at the terminal block/circuit breaker.
- 7) The BTUH output = (Voltage x Amps x 3.41)

$$\text{CFM} = \frac{\text{output (BTUH)}}{1.08 \times \text{temperature rise}}$$

Should the CFM need to be increased or decreased it may be done by adjusting the blower speed tap as shown on the wiring diagram.

## **START-UP**

- Prior to initial start-up insure that all electrical connections are properly sized and tightened.
- All panels must be in place and secured.
- Tubing should be leak free.
- Unit should be elevated, trapped and pitched to allow for drainage.
- Low voltage wiring is connected.
- Auxiliary drain is installed, when necessary, and pitched to allow for drainage.
- Drain pans and drain tubing were leak checked with water.
- Return and supply ducts are sealed.
- Unit is elevated when installed in a garage or where flammable vapors may be present.
- Unit is protected from vehicular or other physical damage.
- Return air is not to be obtained from any areas where there may be objectionable odors, flammable vapors or products of combustion such as carbon monoxide (CO) which may cause serious personal injury or death.

## **REGULAR MAINTENANCE**

<b>WARNING</b>
----------------

<b>DISCONNECT ALL POWER SUPPLIES BEFORE PERFORMING ANY SERVICE.</b>
---

The only item to be maintained on a regular basis by the user is to insure that the circulating air filter(s) is cleaned or replaced. It is recommended that a return air filter grille be installed.

A certified service technician should perform other services.

Model Number Explanation

H	B	24	00	V	D	I	M	20
Haier	Blower unit	Nominal capacity in (000) Btuh	Electric heater	Electric Designation	Coil code	Design series	Airflow configuration	Unit Width (In.)
Brand symbol	B: Blower unit; C: Evaporator unit	24: 24000 BTU/h; 60: 60000 BTU/h	00: No; 01: 1KW; 02: 2KW; 15: 15KW	Y: 575V-3Ph-60Hz; V: 208/230V-1Ph-60Hz; C: 208/230V-3Ph-60Hz; D: 460V-3Ph-60Hz; A: 115V-1 Ph-60Hz	A: 10 SEER A/C coil; B: 11 SEER A/C coil; C: 12 SEER A/C coil D: 13 SEER A/C coil	1: 1st Generation	M: Multi-direction; V: Vertical	17: 17" [432mm] 20: 20" [497mm] 22: 22" [559mm]

Table 1

Indoor Unit Model	Outdoor Unit Model	Indoor Unit Piston Size	Indoor Unit Motor Speed
HB2400VD2M20	HC18D1VAR	073	M (Blue)
	HR18D1VAR	059	M (Blue)
HB2400VD2V20	HC24D1VAR	073	H (Black)
	HR24D1VAR	078	H (Black)
HB3600VD2M22	HC30D1VAR	078	L (Blue)
	HR30D1VAR	085	L (Blue)
HB3600VD2V22	HC36D1VAR	091	H (Black)
	HR36D1VAR	085	H (Black)
HB4800VD2M22	HC42D1VAR	087	L (Blue)
	HR42D1VAR	097	L (Blue)
HB4800VD2V22	HC48D1VAR	097	H (Black)
	HR48D1VAR	097	H (Black)
HB6000VD2M22	HC60D1VAR	096	H (Black)
HB6000VD2V22	HR60D1VAR	096	H (Black)
HB6000VD2M22-E	HR60D1VAR	096	H (Black)
HB6000VD2V22-E	HR60D1VAR	096	H (Black)