



Freezer

Use & Care Guide

Congelador

Guía para su uso y cuidado

Congélateur

Guide d'utilisation et d'entretien

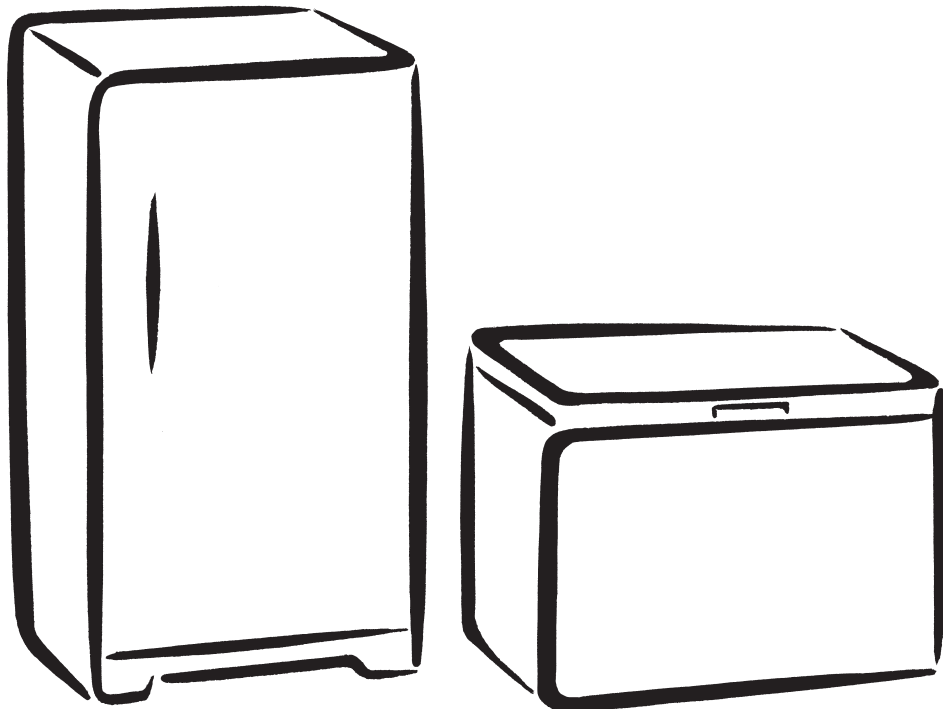

ENGLISH

ESPAÑOL

FRANÇAIS

Sears, Roebuck and Co., Hoffman Estates, IL 60179 U.S.A.
Sears Canada, Inc., Toronto, Ontario, Canada M5B 2B8

www.sears.com
216742200 (0005)

TABLE OF CONTENTS

Record Serial/Model Numbers	2
Safety	2-3
Warranty	3
Canada - Limited Warranty	4
First Steps	5-6
Energy Saving Tips	6
Setting the Temperature Control	6
Freezer Optional Features	7-8
Care and Cleaning	9-10
Power Failure / Freezer Failure	10
Troubleshooting Guide	11-12
Sears Service	13
Sears Canada Customers	13

SERIAL / MODEL NUMBERS

READ AND SAVE THESE INSTRUCTIONS

This Owner's Guide provides specific operating instructions for your model. Use your freezer only as instructed in this guide. These instructions are not meant to cover every possible condition and situation that may occur. Common sense and caution must be practiced when installing, operating, and maintaining any appliance.

Record Your Model and Serial Numbers

Record the model and serial numbers in the space provided below. The serial plates are located either on the upper left wall inside the freezer (upright models), or the left exterior wall (chest models).

Model Number: 253. _____

or 970. _____

Serial Number: _____

Purchase Date: _____

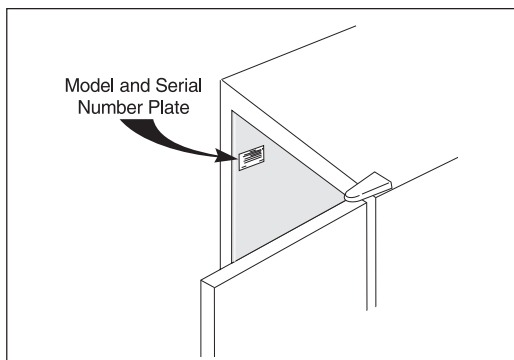

IMPORTANT SAFETY INSTRUCTIONS

READ ALL INSTRUCTIONS BEFORE USING THIS FREEZER.

⚠ WARNING FOR YOUR SAFETY

Do not store or use gasoline, or other flammable vapors and liquids in the vicinity of this or any other appliance. Read product labels for flammability and other warnings.

⚠ WARNING CHILD SAFETY

- Destroy carton, plastic bags, and any exterior wrapping material immediately after the freezer is unpacked. Children should never use these items to play. Cartons covered with rugs, bedspreads, plastic sheets or stretch wrap may become airtight chambers, and can quickly cause suffocation.
- Remove all staples from the carton. Staples can cause severe cuts, and destroy finishes if they come in contact with other appliances or furniture.
- An empty, discarded ice box, refrigerator, or freezer is a very dangerous attraction to children.
- Remove and discard any spacers used to secure the shelves during shipping. Small objects are a choke hazard to children.

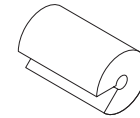

Remove the door(s) of any appliance that is not in use, even if it is being discarded.

Proper Disposal of Your Refrigerator/Freezer

⚠ WARNING Risk of child entrapment. Child entrapment and suffocation are not problems of the past. Junked or abandoned refrigerators or freezers are still dangerous — even if they will sit for "just a few days." If you are getting rid of your old refrigerator or freezer, please follow the instructions below to help prevent accidents.

BEFORE YOU THROW AWAY YOUR OLD REFRIGERATOR/FREEZER:

- Remove doors.
- Leave shelves in place so children may not easily climb inside.

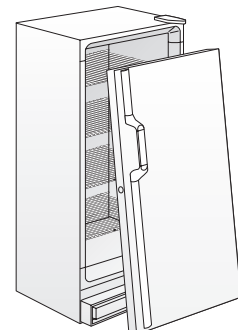

⚠ WARNING ELECTRICAL INFORMATION

These guidelines must be followed to ensure that safety mechanisms in the design of this freezer will operate properly.

- **Refer to the serial plate for correct electrical rating.**
The power cord of the appliance is equipped with a three-prong grounding plug for your protection against shock hazards. It must be plugged directly into a properly grounded three-prong receptacle, protected with a 15 amp time delay fuse or circuit breaker. The receptacle must be installed in accordance with local codes and ordinances. Consult a qualified electrician. Receptacles protected by Ground Fault Circuit Interrupters (GFI) are NOT RECOMMENDED. **Do not use an extension cord or adapter plug.**
- If voltage varies by 10% or more, freezer performance may be affected. Operating freezer with insufficient power can damage the motor. Such damage is not covered under the warranty. If you suspect your household voltage is high or low, consult your power company for testing.
- To prevent the freezer from being turned off accidentally, do not plug unit into an outlet controlled by a wall switch or pull cord.
- Do not pinch, knot, or bend the cord in any manner.

OTHER PRECAUTIONS

- Never unplug the freezer by pulling on the cord. Always grip the plug firmly, and pull straight out from the receptacle.

NOTE: Turning the temperature control to OFF turns off the compressor, but does not disconnect the power to the light bulb or other electrical components.

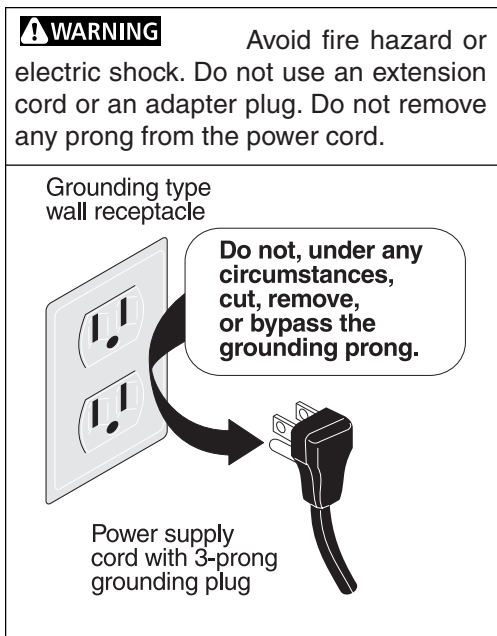

FREEZER WARRANTY

FULL ONE-YEAR WARRANTY ON FREEZER

For one year from the date of purchase, when this freezer is operated and maintained according to the instructions provided in this Owner's Guide, Sears will repair this freezer, free of charge, if defective in material or workmanship.

FULL FIVE-YEAR WARRANTY ON SEALED REFRIGERATION SYSTEM

For five years from the date of purchase, when this freezer is operated and maintained according to the instructions provided in this Owner's Guide, Sears will repair the sealed system (consisting of refrigerant, connecting tube, and compressor), free of charge, if defective in material or workmanship.

The above freezer warranty applies only to freezers which are used for storage of food for private household purposes.

FOOD LOSS COVERAGE LIMITATION

If promptly reported to your nearest Sears store or Service Center, Sears will reimburse you up to a total of \$100.00 for the value of food, as verified by Sears, lost while stored in the freezer when used for private household purposes as a result of:

1. Defects that occur during the first year following the date of purchase.
2. Failure of the sealed refrigeration system (including refrigerant, connecting tubing, and compressor), due to defects that occur during the second through fifth year after purchase. If freezer is used for other than private household purposes, Sears will not be responsible for any food loss. Food losses resulting from other than the above stated defects, such as natural spoilage, power interruption, inadequate power, manual disconnect of power supply, fire damage, water damage, theft, etc., are beyond our control and are not covered by Sears. Some states do not allow the exclusion or limitation of incidental or consequential damages, so the above limitation or exclusion may not apply to you. This warranty gives you specific legal rights, and you may have other rights which vary from state to state.

Warranty service is available by contacting the NEAREST SEARS SERVICE CENTER/DEPARTMENT in the United States. See the back page of this manual.

Sears, Roebuck and Co.
Dept. 817WA
Hoffman Estates, IL 60179

CANADA — LIMITED WARRANTY



Freezers

Sears Canada Inc., warrants every new *Kenmore* freezer to be free from defects in material or workmanship. What Sears will do, free of charge, in case of defect:

What is covered?	How long warranted? (from date of sale)	Parts: At Sears' option, either repair or supply replacement part for:	Labor: Install repaired or replacement part for:
The Compressor	TEN (10) YEARS	TEN (10) YEARS	FIVE (5) YEARS
The Sealed System (consisting of refrigerant, evaporator, and condenser)	FIVE (5) YEARS	FIVE (5) YEARS	FIVE (5) YEARS
All other parts or adjustments	ONE (1) YEAR	ONE (1) YEAR	ONE (1) YEAR

Normal Responsibility of the Customer

The following items, since they are not manufacturing defects, are not included in the warranty, but are the responsibility of the customer:

- 1) Damage to finish after delivery.
- 2) Improper power supply, low voltage, or any defects in the house wiring system or appliance not connected to electric outlet.
- 3) Replacement of light bulbs.
- 4) Damage caused by moving the product from its original installation.
- 5) Service required as a result of alteration, abuse, fire, floods, or acts of God.
- 6) Providing adequate air circulation to the refrigerating system.
- 7) Proper use and care of product as listed in the customer's manual; proper setting of the controls.

If any service is required under this warranty, simply call **1-800-4-MY-HOMESM** (1-800-469-4663).

This warranty is in addition to any statutory warranty. The above warranty covers *Kenmore* Freezers sold and operated in Canada only and shall not apply if the freezer is used for other than domestic purposes.

Sears Maintenance Agreement

Maintain the value of your *Kenmore* freezer with a Sears Maintenance Agreement.

SEARS CANADA INC. • Toronto, Canada • M5B 2B8

ENGLISH

FIRST STEPS

This Owner's Guide provides specific operating instructions for your model. Use the freezer only as instructed in this Owner's Guide. **Before starting the freezer, follow these important first steps.**

INSTALLATION

- Choose a place that is near a grounded electrical outlet. **Do Not** use an extension cord or an adapter plug.
- For the most efficient operation, the freezer should be located where surrounding temperatures will not exceed 110°F (43°C). Temperatures of 32°F (0°C) and below will NOT affect freezer operation. Additional compressor heaters are not recommended.
- *Allow space around the unit for good air circulation.* Leave a 3 inch (75 mm) space on all sides of the freezer for adequate circulation.

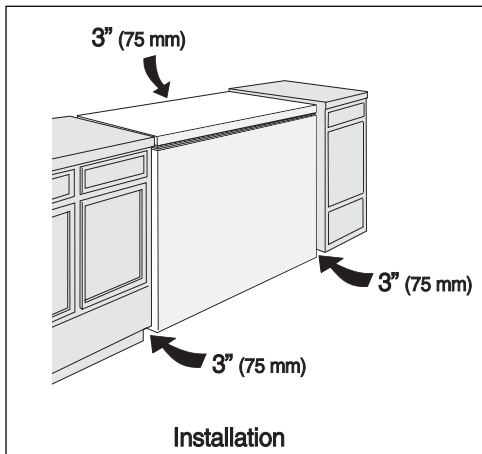

NOTE: The exterior walls of the freezer may become quite warm as the compressor works to transfer heat from the inside. Temperatures as much as 30° F warmer than room temperature can be expected. For this reason it is particularly important in hotter climates to allow enough space for air circulation around your freezer.

LEVELING

The freezer must have all bottom corners resting firmly on a solid floor. The floor must be strong enough to support a fully loaded freezer. **NOTE:** It is **Very Important** for your freezer to be level in order to function properly. If the freezer is not leveled during installation, the door may be misaligned and not close or seal properly, causing cooling, frost, or moisture problems.

To Level Upright Models:

After discarding crating screws and wood base, use a carpenter's level to level the freezer from front-to-back. Adjust the plastic leveling feet in front, ½ bubble higher, so that the door closes easily when left halfway open.

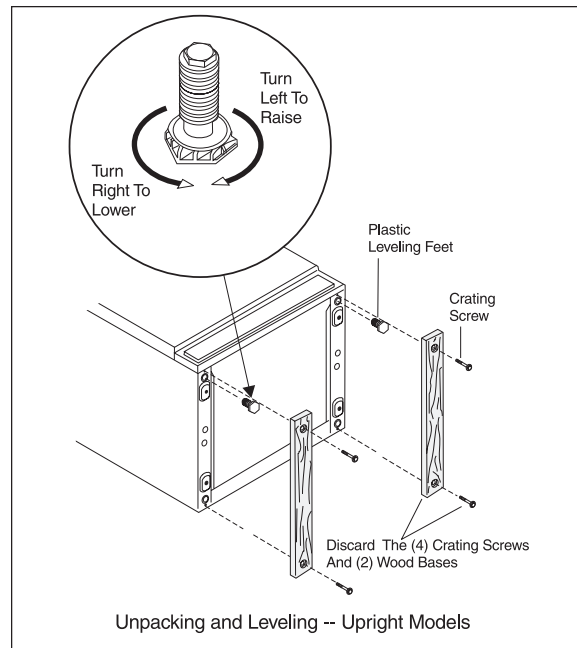

To Level Chest Models:

If needed, add metal or wood shims between foot pads and floor.

CLEANING

- Wash any removable parts, the freezer interior, and exterior with mild detergent and warm water. Wipe dry. **Do not use harsh cleaners on these surfaces.**
- Do not use razor blades or other sharp instruments, which can scratch the appliance surface when removing adhesive labels. Any glue left from the tape can be removed with a mixture of warm water and mild detergent, or touch the residue with the sticky side of tape already removed. **Do not remove the serial plate.**



DOOR REMOVAL (UPRIGHT MODELS)

If door must be removed to fit through narrow doorways:

1. Gently lay freezer on its back, on a throw rug or blanket.
2. Remove the base panel by unscrewing two screws from front of base panel. Remove wire from clips on bottom of cabinet. (Figure 1)
3. Unplug connector by holding the cabinet connector in place, and pulling door connector out. (Figure 1)
4. At the top of the cabinet, lift up plastic hinge cover, and fold back. (Figure 2)
5. Use a Phillips® screwdriver to loosen and retighten the screws on the top hinge to insure a secure assembly, and prevent hinge slippage.
6. Remove the top hinge from cabinet, and lift door off lower hinge pin.
7. After door is removed, remove the two screws from the bottom hinge.
8. To replace door, reverse above order.

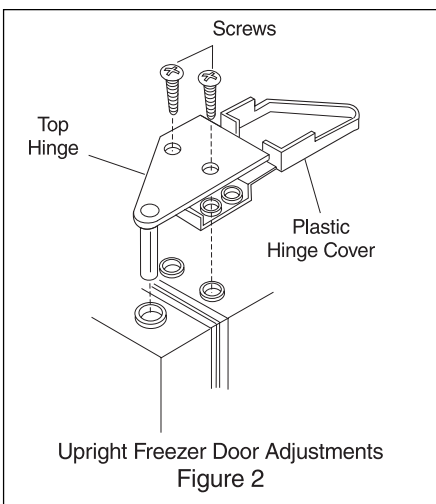
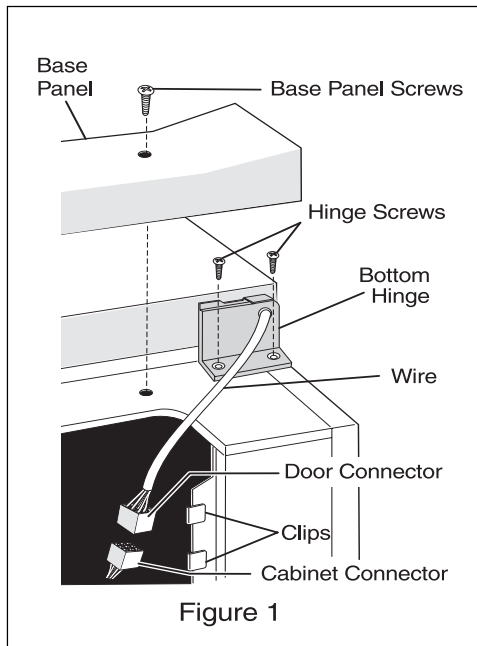

ENERGY SAVING TIPS



- The freezer should be located in the coolest area of the room, away from heat producing appliances or heating ducts, and out of direct sunlight.
- Let hot foods cool to room temperature before placing in the freezer. Overloading the freezer forces the compressor to run longer. Foods that freeze too slowly may lose quality or spoil.
- Be sure to wrap foods properly, and wipe containers dry before placing them in the freezer. This cuts down on frost build-up inside the freezer.
- Freezer shelves should not be lined with aluminum foil, wax paper, or paper toweling. Liners interfere with cold air circulation, making the freezer less efficient.
- Organize and label food to reduce door openings and extended searches. Remove as many items as needed at one time, and close the door as soon as possible.

SETTING THE TEMPERATURE CONTROL

COOL DOWN PERIOD

- For safe food storage, allow 4 hours for the freezer to cool down completely. The freezer will run continuously for the first several hours. Foods that are already frozen may be placed in the freezer after the first few hours of operation. Unfrozen foods should NOT be loaded into the freezer until the freezer has operated for 4 hours.
- When loading the freezer, freeze only 3 pounds of fresh food per cubic foot of freezer space at one time. Distribute packages to be frozen evenly throughout the freezer. It is not necessary to turn the control knob to a colder setting while freezing food.

TEMPERATURE CONTROL

The temperature control is located inside the freezer on upright models, and on the left outside wall on chest models. The temperature control should be factory pre-set to number **4**, which will provide satisfactory food storage temperatures. However, the temperature control is adjustable to provide a range of temperatures for your personal satisfaction. If a colder temperature is desired, turn the temperature control knob to a higher number. Adjust by one numerical increment at a time, and allow several hours for temperatures to stabilize between adjustments.

FREEZER OPTIONAL FEATURES

NOTE: Your freezer may have some, or all of the features listed below. Become familiar with these features, and their use and care.

POWER ON LIGHT

The yellow *Power On* indicator light indicates that the freezer is properly connected to electrical power. The light glows even when the temperature control is turned to OFF. If the light goes out, refer to *Freezer Does Not Run* Section in the **Troubleshooting Guide**. If the freezer appears to be operating, the light element may be burned out. Call an authorized servicer for replacement.

TEMP ALARM (SOME MODELS)

This feature is designed to provide a warning if the inside temperatures reach an unsafe level. The Temp. Alarm Feature operates on household electricity. It will not function if household electricity is interrupted.

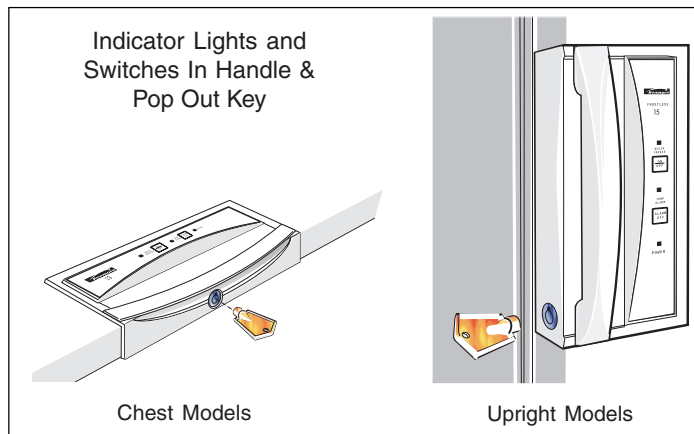

When the freezer is initially plugged in, the red Temp. Alarm Indicator Light blinks. The indicator light will continue to blink until the freezer has reached a safe freezing temperature. If a malfunction causes an unsafe temperature inside the freezer, the red light will blink and the buzzer will sound. To silence the buzzer, press the ALARM OFF button. The Indicator Light will continue to blink until a safe freezing temperature is again reached.

If the ALARM OFF button is not pressed, the buzzer will turn itself off automatically after 48 hours, but the red Temp Alarm Light will continue to blink.

Temp Alarm Indicator Light	Function
Light out, silent buzzer	Normal operation
Blinking RED light, silent buzzer	Initial installation or extended power outage indicates warm temperature.
Blinking RED light, buzzer sounding	Warm temperature condition. To silence buzzer, press TEMP. ALARM OFF button. See Troubleshooting Guide for possible problems.

HIGH-TEMP ALARM SWITCH (SOME MODELS)

An audible alarm will sound if the freezer temperature reaches unsafe levels. The alarm operates on household electricity. If the power fails, the alarm will not perform.

An ON/OFF switch allows the high temperature alarm to be deactivated if desired. **NOTE:** You must open the freezer door to view the alarm switch. The freezer is shipped with the switch in the OFF position. After the freezer has run long enough to lower the temperature, you may set the switch to the ON position.

- To activate the alarm, set the switch to the ON position.
- To deactivate the alarm, set the switch to the OFF position.

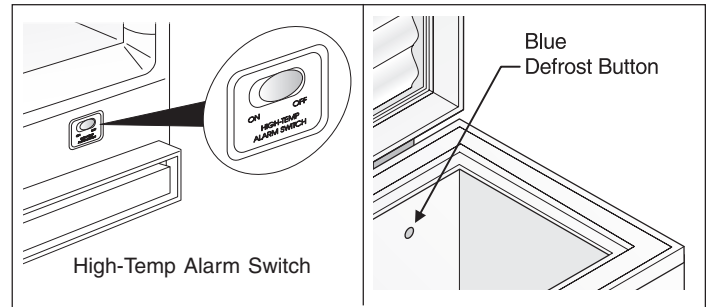

BLUE DEFROST BUTTON (SOME CHEST MODELS)

IMPORTANT: It is time to defrost and clean the freezer when the blue defrost button is completely covered with frost.

QUICK FREEZE (SOME MODELS)

To activate the Quick Freeze feature, push the switch to the ON position. The green light will appear, and the freezer will run continuously (except when in Flash Defrost), driving freezer temperature to the coldest possible temperatures. The switch automatically turns off after 24 hours. Use this feature just prior to adding large quantities of unfrozen foods (not to exceed 3 pounds per cubic foot of freezer space).

FLASH DEFROST (SOME MODELS)

NOTE: The Temp Alarm should be turned off when freezer is being defrosted. The Flash Defrost feature will defrost the freezer in a fraction of the time usually required. To defrost, **remove all food**, and follow these steps:

- Pull out the Flash Defrost plunger. Leave door open while defrosting. (Closing the freezer lid/door will push in the plunger, and the Flash Defrost will be turned off.)
- Push the Flash Defrost plunger in to restart freezer after defrosting.
- Turn on the Temp Alarm after freezer has reached freezing temperatures.

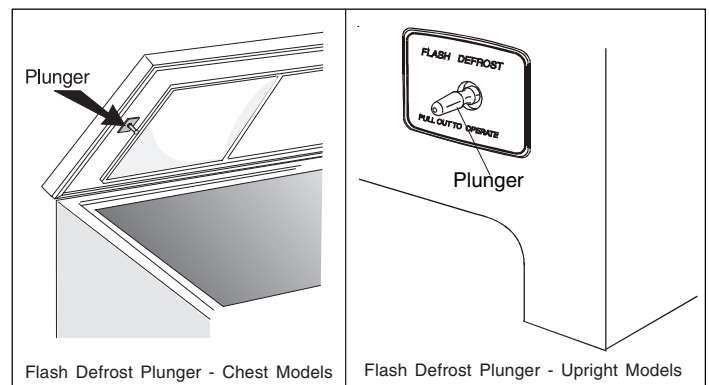

ENGLISH

SLIDE-OUT BASKET OR TRIVET (UPRIGHT MODELS)

A Slide-Out Basket (some models) or Trivet (some models), located at the bottom of the freezer, provides separate storage space for items that are difficult to store on freezer shelves. To remove the basket or trivet, pull out and lift up.

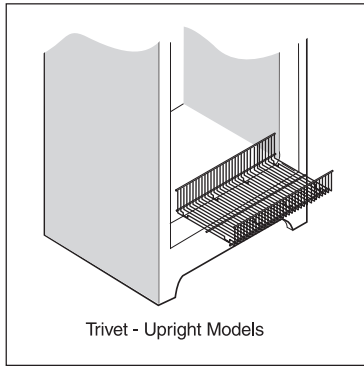

JUICE CAN RACK (UPRIGHT MODELS)

The Juice Can Rack on the freezer door is specially ridged to store juice cans and prevent them from rolling out of the shelf.

SECURITY LOCK WITH POP-OUT KEY

This security lock fastens the door snugly, ensuring stored food is secure. To lock or unlock the freezer, push the key into the lock and turn. The key pops out of the lock after it has been turned.

INTERIOR LIGHT

The light comes on automatically when the door is opened. To replace the light bulb, turn the temperature control to OFF and **unplug the electrical cord**. Replace the old bulb with a bulb of the same wattage.

TILT-OUT SHELF

This shelf is located inside on the freezer door and provides additional storage space. To access an item, tilt top of "basket" shelf down.

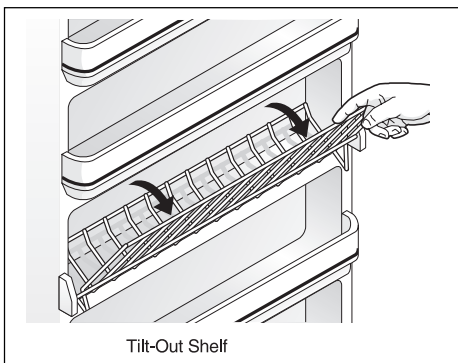

DROP FRONT SHELF (UPRIGHT MODELS)

The Drop Front Shelf, located at the bottom of the freezer, provides a separate compartment for small irregular shaped items or large, bulky items. Lift the shelf front up and out to remove.

ADJUSTABLE INTERIOR SHELVES (UPRIGHT MODELS)

Multi-position adjustable interior shelves can be moved to any position for larger or smaller packages. The shipping spacers that stabilize the shelves for shipping may be removed and discarded.

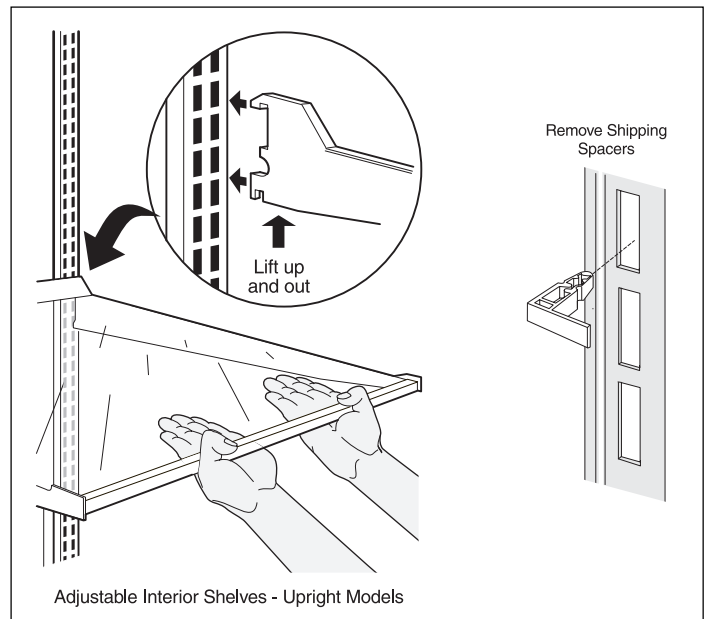
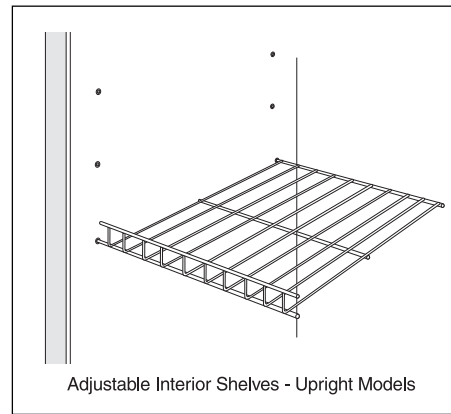

SLIDE-ASIDE BASKET (SOME CHEST MODELS)

This basket helps organize odd-shaped items. To reach other packages in the freezer, slide the basket aside, or lift out.

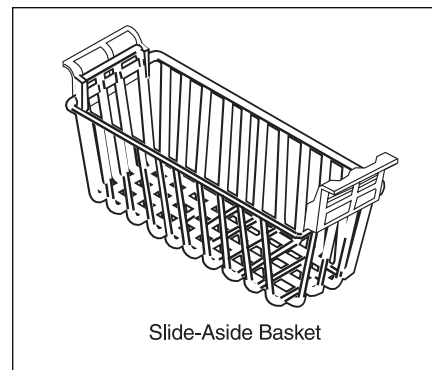

CARE AND CLEANING

⚠ WARNING Damp objects stick to cold metal surfaces. Do not touch interior metal surfaces with wet or damp hands.

Some upright freezers are frost-free and defrost automatically, but should be cleaned occasionally.

BETWEEN DEFROSTINGS

To avoid frequent defrosting, occasionally use a plastic scraper to remove frost. Scrape with a pulling motion. Never use a metal instrument to remove frost.

DEFROSTING

It is important to defrost and clean the freezer when $\frac{1}{4}$ to $\frac{1}{2}$ inch of frost has accumulated. Frost may tend to accumulate faster on the upper part of the freezer due to warm, moist air entering the freezer when the door is opened. Remove food and leave the door open when defrosting the freezer.

- **On upright models** with a defrost drain (Figure 1), remove the drain plug on the inside floor of the freezer by pulling straight out. To access the external drain tube on models with a base panel, first remove the two screws from the base panel. Locate the drain tube near the left center under the freezer. Place a shallow pan under the drain tube. Defrost water will drain out. Check pan occasionally so water does not overflow. A $\frac{1}{2}$ inch garden hose adaptor can be used to drain the freezer directly into a floor drain. If your model is not equipped with an adaptor, one can be purchased at most hardware stores. Replace the drain plug when defrosting and cleaning are completed. If the drain is left open, warm air may enter the freezer.

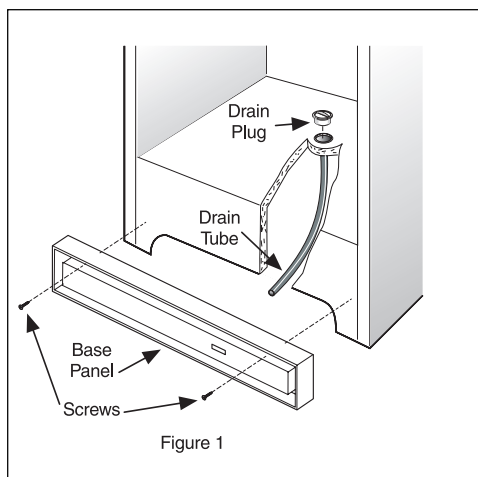

- **On chest models** with a defrost drain, place a shallow pan or the Divider/Drain Pan (some models) beneath the drain outlet (Figure 2). A $\frac{1}{2}$ inch garden hose adaptor can be used to drain the freezer directly into a floor drain (Figure 3). Pull out the drain plug inside the freezer, and pull off the outside defrost drain plug (Figure 4).

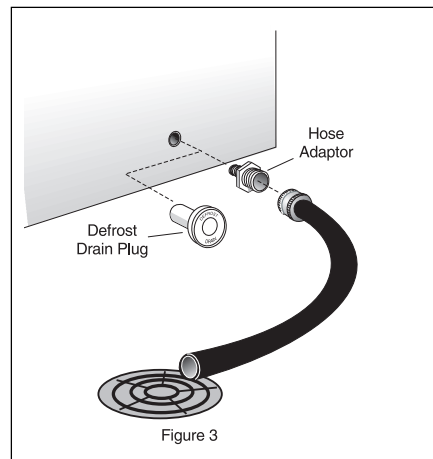
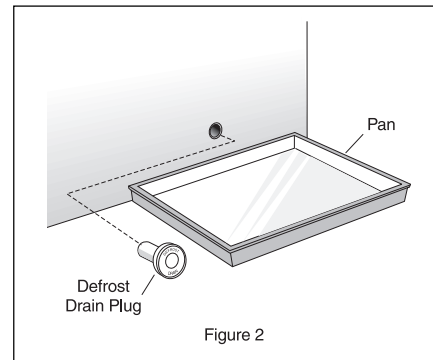

Defrost water will drain out. Check pan occasionally so water does not overflow. Replace the drain plugs when defrosting is completed.

- **On models without a defrost drain**, place towels or newspapers on the freezer bottom to catch the frost. The frost will loosen and fall. Remove towels and/or newspapers.
- If the frost is soft, remove it by using a plastic scraper. If the frost is glazed and hard, fill deep pans with hot water and place them on the freezer bottom. Close the freezer door. Frost should soften in about 15 minutes. Repeat this procedure if necessary.

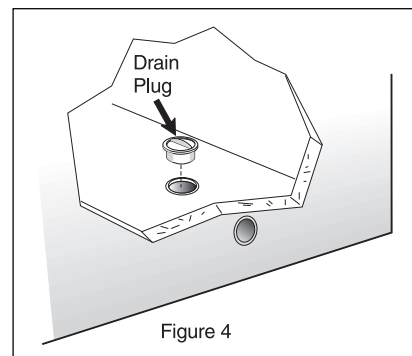

CLEANING THE INSIDE

After defrosting, wash inside surfaces of the freezer with a solution of two tablespoons of baking soda in one quart (1.136 litres) warm water. Rinse and dry. Wring excess water out of the sponge or cloth when cleaning in the area of the controls, or any electrical parts.

Wash the removable parts and door basket with the baking soda solution mentioned above, or mild detergent and warm water. Rinse and dry. **Never** use metallic scouring pads, brushes, abrasive cleaners, or alkaline solutions on any surface. Do not wash removable parts in a dishwasher.

CLEANING THE OUTSIDE

Wash the cabinet with warm water and mild liquid detergent. Rinse well and wipe dry with a clean soft cloth. Replace parts and food.

⚠ WARNING If leaving the freezer door open while on vacation, make certain that children cannot get into the freezer and become entrapped.

VACATION AND MOVING TIPS

Short Vacations:

Leave the freezer operating during vacations of less than three weeks.

Long Vacations:

If the freezer will not be used for several months:

- Remove all food and unplug the power cord.
- Clean and dry the interior thoroughly.
- Leave the freezer door open slightly, blocking it open if necessary, to prevent odor and mold growth.

Moving: When moving the freezer, follow these guidelines to prevent damage:

- Disconnect the power cord plug from the wall outlet.
- Remove foods, then defrost, and clean the freezer.
- Secure all loose items such as base panel, baskets, and shelves by taping them securely in place to prevent damage.
- In the moving vehicle, secure freezer in an upright position to prevent movement. Also protect outside of freezer with a blanket, or similar item.

POWER FAILURE / FREEZER FAILURE

NOTE: Do not open freezer door unnecessarily if freezer is off for several hours.

If a power failure occurs, frozen foods will stay frozen for at least 24 hours if the freezer is kept closed. If the power failure continues, pack seven or eight pounds of dry ice into the freezer every 24 hours. Look in the Yellow Pages under *Dry Ice, Dairies, or Ice Cream Manufacturers* for local dry ice suppliers. Always wear gloves and use caution when handling dry ice.

If the freezer has stopped operating, see *Freezer Does Not Run* in the **Troubleshooting Guide**. If you cannot solve the problem, call an authorized servicer immediately.

If the freezer remains off for several hours, follow the directions above for the use of dry ice during a power failure. If necessary, take the food to a local locker plant until the freezer is ready to operate. Look in the Yellow Pages under *Frozen Food Locker Plants*.

TROUBLESHOOTING GUIDE		Before calling for service, review this list. It may save you time and expense. This list includes common occurrences that are not the result of defective workmanship or materials in this appliance.	
PROBLEM	CAUSE	CORRECTION	
<i>FREEZER DOES NOT RUN</i>			
Freezer does not run.	<ul style="list-style-type: none"> Freezer is plugged into a circuit that has a ground fault interrupt. Temperature control is in the OFF position. Freezer may not be plugged in, or plug may be loose. House fuse blown or tripped circuit breaker. Power outage. 	<ul style="list-style-type: none"> Use another circuit. If you are unsure about the outlet, have it checked by a certified technician. See Setting the Temperature Control Section. Ensure plug is tightly pushed into outlet. Check/replace fuse with a 15 amp time-delay fuse. Reset circuit breaker. Check house lights. Call local Electric Company. 	
Freezer runs too much or too long.	<ul style="list-style-type: none"> Room or outside weather is hot. Freezer has recently been disconnected for a period of time. Large amounts of warm or hot food have been stored recently. Doors are opened too frequently or too long. Freezer door may be slightly open. Temperature Control is set too low. Freezer gasket is dirty, worn, cracked, or poorly fitted. 	<ul style="list-style-type: none"> It's normal for the freezer to work harder under these conditions. It takes 4 hours for the freezer to cool down completely. Warm food will cause freezer to run more until the desired temperature is reached. Warm air entering the freezer causes it to run more. Open doors less often. See "DOOR PROBLEMS" Section. Turn control knob to a warmer setting. Allow several hours for the temperature to stabilize. Clean or change gasket. Leaks in the door seal will cause freezer to run longer in order to maintain desired temperature. 	
Interior Freezer temperature is too cold.	<ul style="list-style-type: none"> Temperature Control is set too low. 	<ul style="list-style-type: none"> Turn the control to a warmer setting. Allow several hours for the temperature to stabilize. 	
Interior Freezer temperature is too warm.	<ul style="list-style-type: none"> Temperature Control is set too warm. Door is kept open too long or is opened too frequently. Door may not be seating properly. Large amounts of warm or hot food may have been stored recently. Freezer has recently been disconnected for a period of time. 	<ul style="list-style-type: none"> Turn control to a colder setting. Allow several hours for the temperature to stabilize. Warm air enters the freezer every time the door is opened. Open the door less often. See "DOOR PROBLEMS" Section. Wait until the freezer has had a chance to reach its selected temperature. Freezer requires 4 hours to cool down completely. 	
Freezer external surface temperature is warm.	<ul style="list-style-type: none"> The external freezer walls can be as much as 30°F warmer than room temperature. 	<ul style="list-style-type: none"> This is normal while the compressor works to transfer heat from inside the freezer cabinet. 	
<i>SOUND AND NOISE</i>			
Louder sound levels whenever freezer is on.	<ul style="list-style-type: none"> Modern freezers have increased storage capacity and more stable temperatures. They require a high efficiency compressor. 	<ul style="list-style-type: none"> This is normal. When the surrounding noise level is low, you might hear the compressor running while it cools the interior. 	
Longer sound levels when compressor comes on.	<ul style="list-style-type: none"> Freezer operates at higher pressures during the start of the ON cycle. 	<ul style="list-style-type: none"> This is normal. Sound will level off or disappear as freezer continues to run. 	

PROBLEM	CAUSE	CORRECTION
SOUND AND NOISE (Cont.)		
Popping or cracking sound when compressor comes on.	<ul style="list-style-type: none"> • Metal parts undergo expansion and contraction, as in hot water pipes. 	<ul style="list-style-type: none"> • This is normal. Sound will level off or disappear as freezer continues to run.
Bubbling or gurgling sound, like water boiling.	<ul style="list-style-type: none"> • Refrigerant (used to cool freezer) is circulating throughout the system. 	<ul style="list-style-type: none"> • This is normal.
Vibrating or rattling noise.	<ul style="list-style-type: none"> • Freezer is not level. It rocks on the floor when it is moved slightly. • Floor is uneven or weak. Freezer rocks on floor when it is moved slightly. • Freezer is touching the wall. 	<ul style="list-style-type: none"> • Level the unit. Refer to "Leveling" in the First Steps Section. • Ensure floor can adequately support freezer. Level the freezer by putting wood or metal shims under part of the freezer. • Relevel the freezer or move freezer slightly. Refer to "Leveling" in the First Steps Section.
WATER/MOISTURE/FROST INSIDE FREEZER		
Moisture forms on inside freezer walls.	<ul style="list-style-type: none"> • Weather is hot and humid, which increases internal rate of frost build-up. • Door may not be seating properly. • Door is kept open too long, or is opened too frequently. 	<ul style="list-style-type: none"> • This is normal. • See "DOOR PROBLEMS" Section. • Open the door less often.
WATER/MOISTURE/FROST OUTSIDE FREEZER		
Moisture forms on outside of freezer.	<ul style="list-style-type: none"> • Door may not be seating properly, causing the cold air from inside the freezer to meet warm moist air from outside. 	<ul style="list-style-type: none"> • See "DOOR PROBLEMS" Section.
ODOR IN FREEZER		
Odors in freezer	<ul style="list-style-type: none"> • Interior needs to be cleaned. • Foods with strong odors are in the freezer. 	<ul style="list-style-type: none"> • Clean interior with sponge, warm water, and baking soda. • Cover the food tightly.
DOOR PROBLEMS		
Door will not close.	<ul style="list-style-type: none"> • Freezer is not level. It rocks on the floor when it is moved slightly. • Floor is uneven or weak. Freezer rocks on floor when it is moved slightly. 	<ul style="list-style-type: none"> • This condition can force the cabinet out of square and misalign the door. Refer to "Leveling" in the First Steps Section. • Level the floor by using wood or metal shims under the freezer or brace floor supporting the freezer.
LIGHT BULB IS NOT ON		
Light bulb is not on.	<ul style="list-style-type: none"> • Light bulb is burned out. • No electric current is reaching the freezer. 	<ul style="list-style-type: none"> • Follow directions under "Interior Light" in the Freezer Features Section. • See "FREEZER DOES NOT RUN" Section.

SEARS SERVICE

"We Service What We Sell" is our assurance you can depend on Sears for service ...and Sears service is nationwide. Your freezer has added value when you consider that Sears has service units nationwide, staffed with professional technicians specifically trained on Sears appliances and having parts, tools and equipment to ensure that we meet our pledge to you..."We Service What We Sell."

SEARS MAINTENANCE AGREEMENT

Maintain the value of your *Kenmore*® freezer with a Sears Maintenance Agreement. Sears freezers are designed, manufactured, and tested for years of dependable operation. Yet, any modern appliance may require service from time to time.

The Sears Maintenance Agreement

- Is your way to buy tomorrow's service at today's price.
- Eliminates repair bills resulting from normal use.
- Allows for as many service calls as required.
- Provides for service by professional Sears-trained technicians.
- Offers an annual preventive maintenance check-up at your request.

This maintenance agreement does not cover original installation, reinstallation, or damage resulting from external causes such as acts of God, abuse, theft, fire, flood, wind, lightning, freezing, power failure, power reduction, etc. Please ask a salesperson to see the agreement for all of the terms and conditions.

SEARS CANADA CUSTOMERS

Dear Customer:

In manufacturing this product, many steps have been taken to provide you with the highest quality. Unfortunately, errors or omissions occasionally occur. In the event you find a missing or defective part, please contact your nearest Sears store. (See the back cover for phone numbers.)

If you have any suggestions that would help us to improve our assembly/operation instructions or this product, please write them down, including the information listed below and mail to:

Sears Canada, Inc. Attn: Buyer Dept. 646
222 Jarvis Street
Toronto, Ontario
M5B 2B8

Purchased by:

Name: _____

Address: _____

City: _____ Prov.: _____

Postal Code: _____ Phone: _____

Model No.: 970. _____

Serial No.: _____

Date of Purchase ___/___/___

Location of Purchase _____

Comments: _____

ENGLISH

