

OPERATOR'S MANUAL

Lawn Tractor

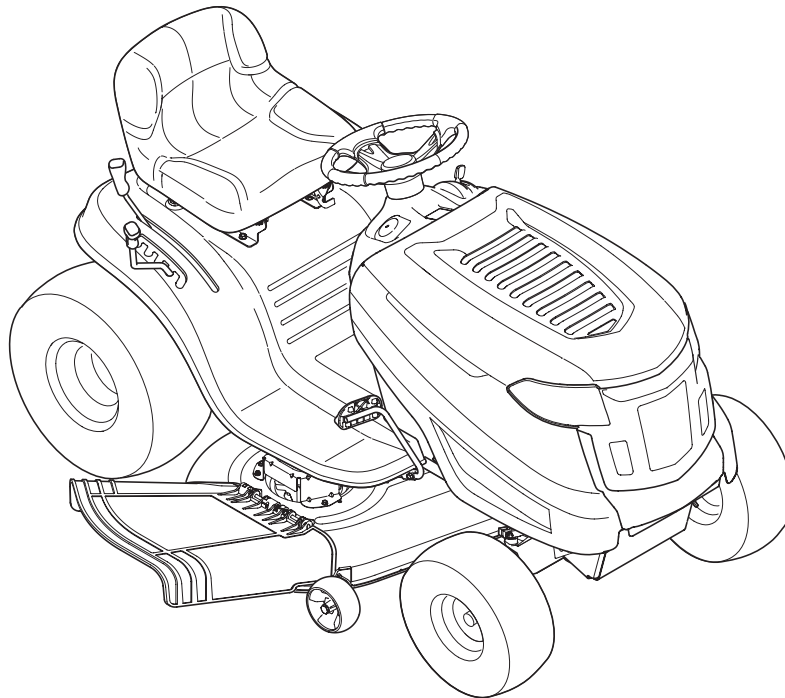

Table of Contents

<i>Safe Operation Practices</i>	2	<i>Service</i>	15
<i>Assembly & Set-Up</i>	7	<i>Troubleshooting</i>	20
<i>Controls & Operation</i>	11	<i>Parts/Warranty</i>	See Separate Supplement

⚠ WARNING

**READ AND FOLLOW ALL SAFETY RULES AND INSTRUCTIONS IN THIS MANUAL
BEFORE ATTEMPTING TO OPERATE THIS MACHINE.
FAILURE TO COMPLY WITH THESE INSTRUCTIONS MAY RESULT IN PERSONAL INJURY.**

NOTE: This Operator's Manual covers several models. Features may vary by model. Not all features in this manual are applicable to all models and the model depicted may differ from yours.

Important Safe Operation Practices



WARNING! This symbol points out important safety instructions which, if not followed, could endanger the personal safety and/or property of yourself and others. Read and follow all instructions in this manual before attempting to operate this machine. Failure to comply with these instructions may result in personal injury.

When you see this symbol. **HEED ITS WARNING!**

CALIFORNIA PROPOSITION 65



WARNING! Engine Exhaust, some of its constituents, and certain vehicle components contain or emit chemicals known to State of California to cause cancer and birth defects or other reproductive harm.



WARNING! Battery posts, terminals, and related accessories contain lead and lead compounds, chemicals known to the State of California to cause cancer and reproductive harm. Wash hands after handling



DANGER! This machine was built to be operated according to the safe operation practices in this manual. As with any type of power equipment, carelessness or error on the part of the operator can result in serious injury. This machine is capable of amputating hands and feet and throwing objects. Failure to observe the following safety instructions could result in serious injury or death.

General Operation

1. Read, understand, and follow all instructions on the machine and in the manual(s) before attempting to assemble and operate. Keep this manual in a safe place for future and regular reference and for ordering replacement parts.
2. Be familiar with all controls and their proper operation. Know how to stop the machine and disengage them quickly.
3. Never allow children under 14 years of age to operate this machine. Children 14 and over should read and understand the instructions and safe operation practices in this manual and on the machine and should be trained and supervised by an adult.
4. Never allow adults to operate this machine without proper instruction.
5. To help avoid blade contact or a thrown object injury, keep bystanders, helpers, children and pets at least 75 feet from the machine while it is in operation. Stop machine if anyone enters the area.
6. Thoroughly inspect the area where the equipment is to be used. Remove all stones, sticks, wire, bones, toys, and other foreign objects which could be picked up and thrown by the blade(s). Thrown objects can cause serious personal injury.
7. Plan your mowing pattern to avoid discharge of material toward roads, sidewalks, bystanders and the like. Also, avoid discharging material against a wall or obstruction which may cause discharged material to ricochet back toward the operator.
8. Always wear safety glasses or safety goggles during operation and while performing an adjustment or repair to protect your eyes. Thrown objects which ricochet can cause serious injury to the eyes.
9. Wear sturdy, rough-soled work shoes and close-fitting slacks and shirts. Loose fitting clothes and jewelry can be caught in movable parts. Never operate this machine in bare feet or sandals.
10. Be aware of the mower and attachment discharge direction and do not point it at anyone. Do not operate the mower without the discharge cover or entire grass catcher in its proper place.
11. Do not put hands or feet near rotating parts or under the cutting deck. Contact with the blade(s) can amputate hands and feet.
12. A missing or damaged discharge cover can cause blade contact or thrown object injuries.
13. Stop the blade(s) when crossing gravel drives, walks, or roads and while not cutting grass.
14. Watch for traffic when operating near or crossing roadways. This machine is not intended for use on any public roadway.
15. Do not operate the machine while under the influence of alcohol or drugs.
16. Mow only in daylight or good artificial light.
17. Never carry passengers.
18. Disengage blade(s) before shifting into reverse. Back up slowly. Always look down and behind before and while backing to avoid a back-over accident.
19. Slow down before turning. Operate the machine smoothly. Avoid erratic operation and excessive speed.
20. Disengage blade(s), set parking brake, stop engine and wait until the blade(s) come to a complete stop before removing grass catcher, emptying grass, unclogging chute, removing any grass or debris, or making any adjustments.
21. Never leave a running machine unattended. Always turn off blade(s), place transmission in neutral, set parking brake, stop engine and remove key before dismounting.
22. Use extra care when loading or unloading the machine into a trailer or truck. This machine should not be driven up or down ramp(s), because the machine could tip over, causing serious personal injury. The machine must be pushed manually on ramp(s) to load or unload properly.
23. Muffler and engine become hot and can cause a burn. Do not touch.
24. Check overhead clearances carefully before driving under low hanging tree branches, wires, door openings etc., where the operator may be struck or pulled from the machine, which could result in serious injury.
25. Disengage all attachment clutches, depress the brake pedal completely and shift into neutral before attempting to start engine.
26. Your machine is designed to cut normal residential grass of a height no more than 10". Do not attempt to mow through unusually tall, dry grass (e.g., pasture) or piles of dry leaves. Dry grass or leaves may contact the engine exhaust and/or build up on the mower deck presenting a potential fire hazard.
27. Use only accessories and attachments approved for this machine by the machine manufacturer. Read, understand and follow all instructions provided with the approved accessory or attachment.
28. Data indicates that operators, age 60 years and above, are involved in a large percentage of riding mower-related injuries. These operators should evaluate their ability to operate the riding mower safely enough to protect themselves and others from serious injury.

- If situations occur which are not covered in this manual, use care and good judgment. Contact your customer service representative for assistance.

Slope Operation

Slopes are a major factor related to loss of control and tip-over accidents which can result in severe injury or death. All slopes require extra caution. If you cannot back up the slope or if you feel uneasy on it, do not mow it.

For your safety, use the slope gauge included as part of this manual to measure slopes before operating this machine on a sloped or hilly area. If the slope is greater than 15 degrees as shown on the slope gauge, do not operate this machine on that area or serious injury could result.

Do:

- Mow up and down slopes, not across. Exercise extreme caution when changing direction on slopes.
- Watch for holes, ruts, bumps, rocks, or other hidden objects. Uneven terrain could overturn the machine. Tall grass can hide obstacles.
- Use slow speed. Choose a low enough speed setting so that you will not have to stop or shift while on the slope. Tires may lose traction on slopes even though the brakes are functioning properly. Always keep machine in gear when going down slopes to take advantage of engine braking action.
- Follow the manufacturer's recommendations for wheel weights or counterweights to improve stability.
- Use extra care with grass catchers or other attachments. These can change the stability of the machine.
- Keep all movement on the slopes slow and gradual. Do not make sudden changes in speed or direction. Rapid engagement or braking could cause the front of the machine to lift and rapidly flip over backwards which could cause serious injury.
- Avoid starting or stopping on a slope. If tires lose traction, disengage the blade(s) and proceed slowly straight down the slope.

Do Not:

- Do not turn on slopes unless necessary; then, turn slowly and gradually downhill, if possible.
- Do not mow near drop-offs, ditches or embankments. The mower could suddenly turn over if a wheel is over the edge of a cliff, ditch, or if an edge caves in.
- Do not try to stabilize the machine by putting your foot on the ground.
- Do not use a grass catcher on steep slopes.
- Do not mow on wet grass. Reduced traction could cause sliding.
- Do not shift to neutral and coast downhill. Over-speeding may cause the operator to lose control of the machine resulting in serious injury or death.

- Do not tow heavy pull behind attachments (e.g. loaded dump cart, lawn roller, etc.) on slopes greater than 5 degrees. When going down hill, the extra weight tends to push the tractor and may cause you to lose control (e.g. tractor may speed up, braking and steering ability are reduced, attachment may jack-knife and cause tractor to overturn).

Children

- Tragic accidents can occur if the operator is not alert to the presence of children. Children are often attracted to the machine and the mowing activity. They do not understand the dangers. Never assume that children will remain where you last saw them.
 - Keep children out of the mowing area and in watchful care of a responsible adult other than the operator.
 - Be alert and turn machine off if a child enters the area.
 - Before and while backing, look behind and down for small children.
 - Never carry children, even with the blade(s) shut off. They may fall off and be seriously injured or interfere with safe machine operation.
 - Use extreme care when approaching blind corners, doorways, shrubs, trees or other objects that may block your vision of a child who may run into the path of the machine.
 - To avoid back-over accidents, always disengage the cutting blade(s) before shifting into Reverse. If equipped, the "Reverse Caution Mode" should not be used when children or others are around.
 - Keep children away from hot or running engines. They can suffer burns from a hot muffler.
 - Remove key when machine is unattended to prevent unauthorized operation.
- Never allow children under 14 years of age to operate this machine. Children 14 and over should read and understand the instructions and safe operation practices in this manual and on the machine and should be trained and supervised by an adult.

Towing

- Tow only with a machine that has a hitch designed for towing. Do not attach towed equipment except at the hitch point.
- Follow the manufacturer's recommendation for weight limits for towed equipment and towing on slopes.
- Never allow children or others in or on towed equipment.

- On slopes, the weight of the towed equipment may cause loss of traction and loss of control.
- Always use extra caution when towing with a machine capable of making tight turns (e.g. "zero-turn" ride-on mower). Make wide turns to avoid jack-knifing.
- Travel slowly and allow extra distance to stop.
- Do not shift to neutral and coast downhill.

Service

Safe Handling of Gasoline:

- To avoid personal injury or property damage use extreme care in handling gasoline. **Gasoline is extremely flammable and the vapors are explosive.** Serious personal injury can occur when gasoline is spilled on yourself or your clothes which can ignite. Wash your skin and change clothes immediately.
 - Use only an approved gasoline container.
 - Never fill containers inside a vehicle or on a truck or trailer bed with a plastic liner. Always place containers on the ground away from your vehicle before filling.
 - When practical, remove gas-powered equipment from the truck or trailer and refuel it on the ground. If this is not possible, then refuel such equipment on a trailer with a portable container, rather than from a gasoline dispenser nozzle.
 - Keep the nozzle in contact with the rim of the fuel tank or container opening at all times until fueling is complete. Do not use a nozzle lock-open device.
 - Extinguish all cigarettes, cigars, pipes and other sources of ignition.
 - Never fuel machine indoors.
 - Never remove gas cap or add fuel while the engine is hot or running. Allow engine to cool at least two minutes before refueling.
 - Never over fill fuel tank. Fill tank to no more than 1/2 inch below bottom of filler neck to allow space for fuel expansion.
 - Replace gasoline cap and tighten securely.
 - If gasoline is spilled, wipe it off the engine and equipment. Move machine to another area. Wait 5 minutes before starting the engine.
 - To reduce fire hazards, keep machine free of grass, leaves, or other debris build-up. Clean up oil or fuel spillage and remove any fuel soaked debris.

- l. Never store the machine or fuel container inside where there is an open flame, spark or pilot light as on a water heater, space heater, furnace, clothes dryer or other gas appliances.
- m. Allow a machine to cool at least five minutes before storing.

General Service

1. Never run an engine indoors or in a poorly ventilated area. Engine exhaust contains carbon monoxide, an odorless, and deadly gas.
2. Before cleaning, repairing, or inspecting, make certain the blade(s) and all moving parts have stopped. Disconnect the spark plug wire and ground against the engine to prevent unintended starting.
3. Periodically check to make sure the blades come to complete stop within approximately (5) five seconds after operating the blade disengagement control. If the blades do not stop within the this time frame, your machine should be serviced professionally by an authorized MTD Service Dealer.
4. Check brake operation frequently as it is subjected to wear during normal operation. Adjust and service as required.
5. Check the blade(s) and engine mounting bolts at frequent intervals for proper tightness. Also, visually inspect blade(s) for damage (e.g., excessive wear, bent, cracked). Replace the blade(s) with the original equipment manufacturer's (O.E.M.) blade(s) only, listed in this manual. "Use of parts which do not meet the original equipment specifications may lead to improper performance and compromise safety!"
6. Mower blades are sharp. Wrap the blade or wear gloves, and use extra caution when servicing them.
7. Keep all nuts, bolts, and screws tight to be sure the equipment is in safe working condition.
8. Never tamper with the safety interlock system or other safety devices. Check their proper operation regularly.
9. After striking a foreign object, stop the engine, disconnect the spark plug wire(s) and ground against the engine. Thoroughly inspect the machine for any damage. Repair the damage before starting and operating.
10. Never attempt to make adjustments or repairs to the machine while the engine is running.
11. Grass catcher components and the discharge cover are subject to wear and damage which could expose moving parts or allow objects to be thrown. For safety protection, frequently check components and replace immediately with original equipment manufacturer's (O.E.M.) parts only, listed in this manual. "Use of parts which do not meet the original equipment specifications may lead to improper performance and compromise safety!"
12. Do not change the engine governor settings or over-speed the engine. The governor controls the maximum safe operating speed of the engine.
13. Maintain or replace safety and instruction labels, as necessary.
14. Observe proper disposal laws and regulations for gas, oil, etc. to protect the environment.
15. According to the Consumer Products Safety Commission (CPSC) and the U.S. Environmental Protection Agency (EPA), this product has an *Average Useful Life* of seven (7) years, or 270 hours of operation. At the end of the *Average Useful Life* have the machine inspected annually by an authorized service dealer to ensure that all mechanical and safety systems are working properly and not worn excessively. Failure to do so can result in accidents, injuries or death.

Do not modify engine

To avoid serious injury or death, do not modify engine in any way. Tampering with the governor setting can lead to a runaway engine and cause it to operate at unsafe speeds. Never tamper with factory setting of engine governor.

Notice Regarding Emissions

Engines which are certified to comply with California and federal EPA emission regulations for SORE (Small Off Road Equipment) are certified to operate on regular unleaded gasoline, and may include the following emission control systems: Engine Modification (EM), Oxidizing Catalyst (OC), Secondary Air Injection (SAI) and Three Way Catalyst (TWC) if so equipped.

When required, models are equipped with low permeation fuel lines and fuel tanks for evaporative emission control. California models may also include a carbon canister. Please contact Customer Support for information regarding the evaporative emission control configuration for your model.

Spark Arrestor













WARNING! This machine is equipped with an internal combustion engine and should not be used on or near any unimproved forest-covered, brush covered or grass-covered land unless the engine's exhaust system is equipped with a spark arrestor meeting applicable local or state laws (if any).

If a spark arrestor is used, it should be maintained in effective working order by the operator. In the State of California the above is required by law (Section 4442 of the California Public Resources Code). Other states may have similar laws. Federal laws apply on federal lands. A spark arrestor for the muffler is available through your nearest engine authorized service dealer or contact the service department, P.O. Box 361131 Cleveland, Ohio 44136-0019.

Safety Symbols

This page depicts and describes safety symbols that may appear on this product. Read, understand, and follow all instructions on the machine before attempting to assemble and operate.

Symbol	Description
	READ THE OPERATOR'S MANUAL(S) Read, understand, and follow all instructions in the manual(s) before attempting to assemble and operate.
	DANGER — ROTATING BLADES Never carry passengers. Never carry children, even with the blades off.
	DANGER — ROTATING BLADES Always look down and behind before and while backing to avoid a back-over accident.
	DANGER — ROTATING BLADES Do not put hands or feet near rotating parts or under the cutting deck. Contact with the blade(s) can amputate hands and feet. Be sure blades and engine are stopped before placing hands or feet near blades.
	DANGER — BYSTANDERS Mowing in reverse is not recommended. Do not mow when children or others are around. Keep bystanders, helpers, children and pets at least 75 feet from the machine while it is in operation.
	DANGER — THROWN OBJECTS This machine may pick up and throw objects which can cause serious personal injury. Remove objects which could be thrown by the blades.
	DANGER — SLOPE OPERATION Go up and down slopes, not across. Use extra caution on slopes. Do not mow slopes greater than 15 degrees. Avoid sudden turns. Use low speed. Do not operate machine where it could tip or slip. If machine stops going uphill, stop blades and back down slowly.
	DANGER — ROTATING BLADES Before leaving operator's position, disengage blades, engage parking brake, shut off engine and remove key. Keep safety devices (guards, shields, switches, etc.) in place and in working order.
	DANGER — HOT SURFACES Allow machine to cool before fueling or storing.
	DANGER — HOT SURFACES Do not drive through piles of dry leaves or tall dry grass. Keep machine free of debris.
	WARNING — HOT SURFACES Operation of this equipment may create sparks that can start fires around dry vegetation. A spark arrestor may be required. The operator should contact local fire agencies for laws or regulations relating to fire prevention requirements.



WARNING! Your Responsibility—Restrict the use of this power machine to persons who read, understand and follow the warnings and instructions in this manual and on the machine.

SAVE THESE INSTRUCTIONS!

Slope Gauge

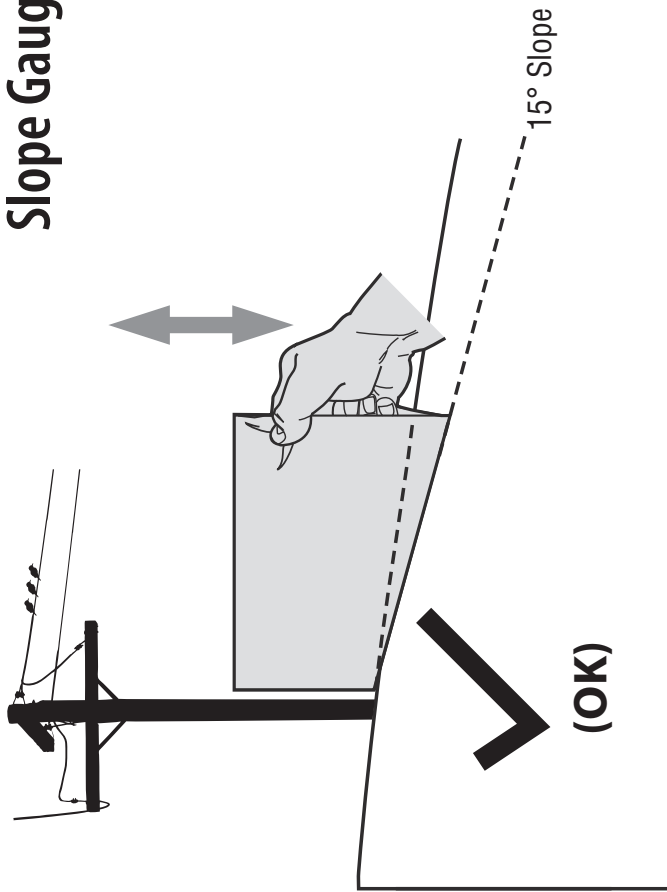

Figure 1

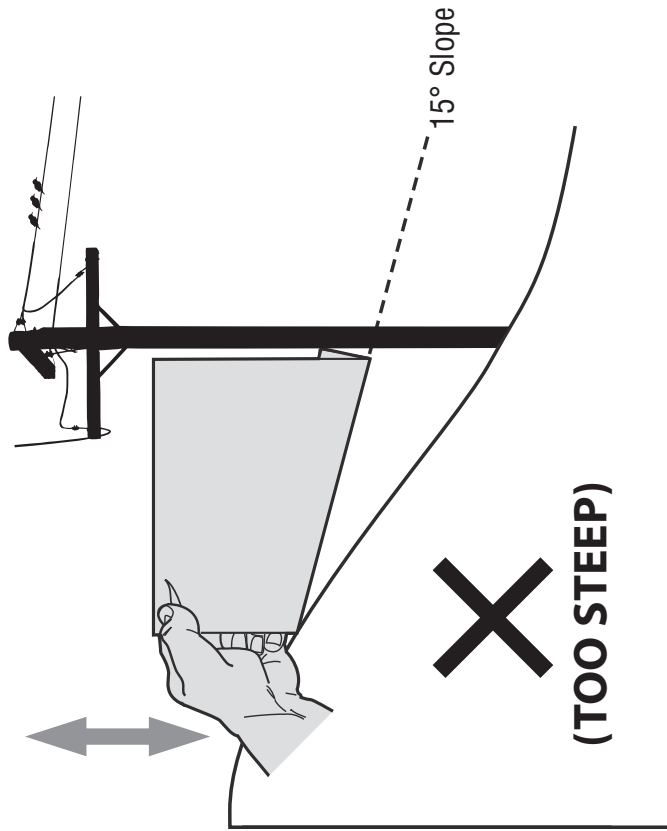

Figure 2

15° dashed line

USE THIS SLOPE GAUGE TO DETERMINE

IF A SLOPE IS TOO STEEP FOR SAFE OPERATION!

To check the slope, proceed as follows:

1. Remove this page and fold along the dashed line.
2. Locate a vertical object on or behind the slope (e.g. a pole, building, fence, tree, etc.)
3. Align either side of the slope gauge with the object (See Figure 1 and Figure 2).
4. Adjust gauge up or down until the left corner touches the slope (See Figure 1 and Figure 2).
5. If there is a gap below the gauge, the slope is too steep for safe operation (See Figure 2 above).



WARNING! Slopes are a major factor related to tip-over and roll-over accidents which can result in severe injury or death.

Do not operate machine on slopes in excess of 15 degrees. All slopes require extra caution. If you cannot back up the slope or if you feel uneasy on it, do not mow it. Always mow up and down slopes, never across the face of slopes.

Thank You

Thank you for purchasing this product. It was carefully engineered to provide excellent performance when properly operated and maintained.

Please read this entire manual prior to operating the equipment. It instructs you how to safely and easily set up, operate and maintain your machine. Please be sure that you, and any other persons who will operate the machine, carefully follow the recommended safety practices at all times. Failure to do so could result in personal injury or property damage.

All information in this manual is relative to the most recent product information available at the time. Review this manual frequently to familiarize yourself with the machine, its features and operation. Please be aware that this Operator's Manual may cover a range of product specifications for various models. Characteristics and features discussed and/or illustrated in this manual may not be applicable to all models. We reserve the right to change product specifications, designs and equipment without notice and without incurring obligation.

If applicable, the power testing information used to establish the power rating of the engine equipped on this machine can be found at www.opei.org or the engine manufacturer's web site.

If you have any problems or questions concerning the machine, phone your local authorized service dealer or contact us directly. We want to ensure your complete satisfaction at all times.

Throughout this manual, all references to *right* and *left* side of the machine are observed from the operating position.

Contents of Carton

- Lawn Tractor (1)
- Ignition Key (2)
- Plastic Oil Drain Sleeve (1) †
- Oil Drain Hose (1) †
- Hood Scoop (1) †
- Steering Wheel (1) -- Cup Washer (1) & Hex Bolt (1)
- Seat (1)
- Dash Shroud (1) †
- Deck Wash Nozzle (1) †
- Hose Coupler (1) †
- Operator's Manual (1)
- Engine Operator's Manual (1)
- Fast Start Guide (1)†
- Parts/Warranty Document (1)
- Product Registration Card (1) †

† — If Equipped

NOTE: This Operator's Manual covers several models. Features may vary by model. Not all features in this manual are applicable to all models and the model depicted may differ from yours. Refer to Figure 2-1 to match your transmission style; Foot Control CVT (Continuously Variable Transmission), CVT (Continuously Variable Transmission) or Hydrostatic.

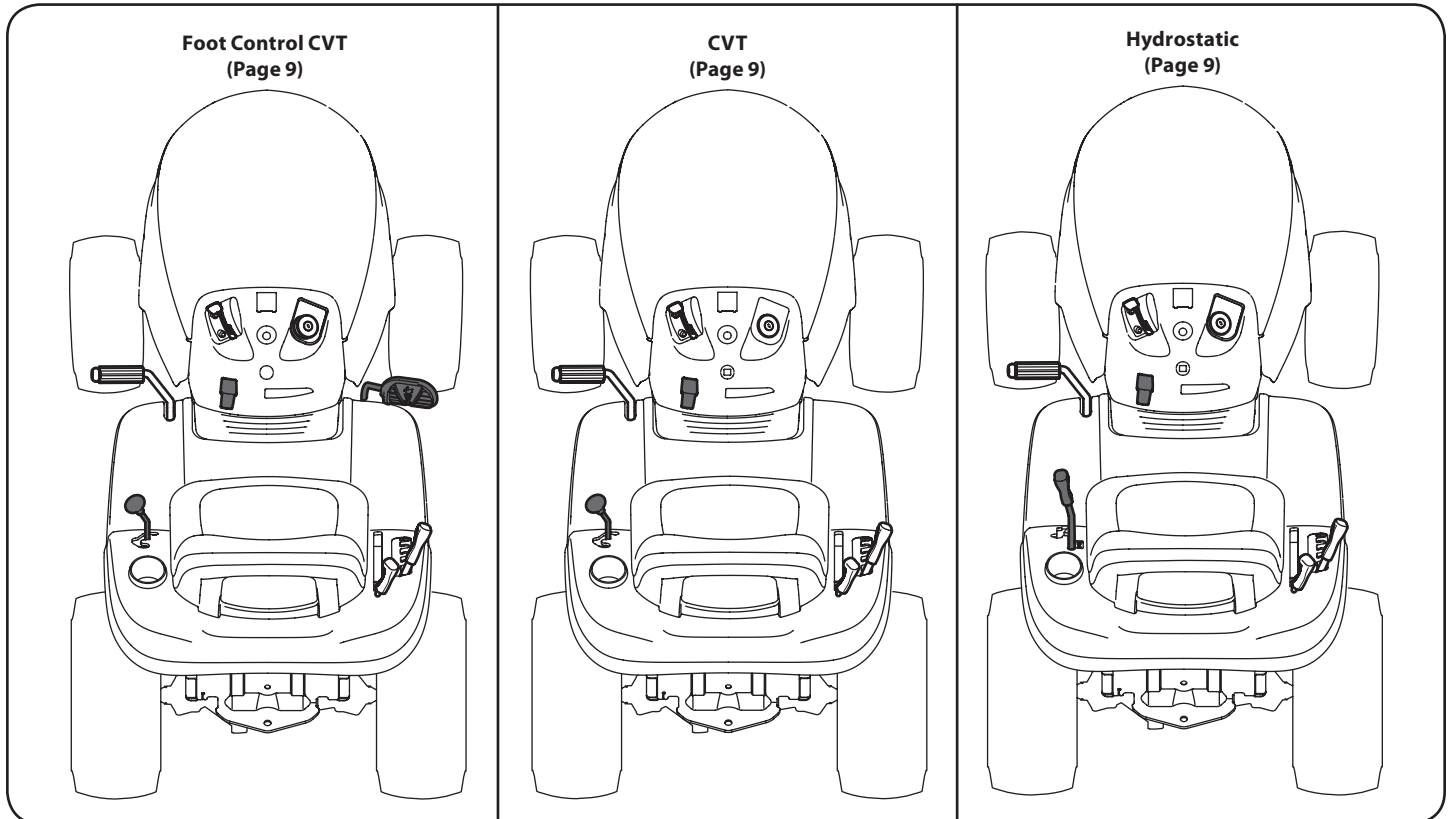

Figure 2-1

Tools Required

- Adjustable Wrench or Socket Set

Connecting the Battery Cables



California PROPOSITION 65

WARNING: Battery posts, terminals, and related accessories contain lead and lead compounds, chemicals known to the State of California to cause cancer and reproductive harm. Wash hands after handling.



CAUTION: When attaching battery cables, always connect the POSITIVE (Red) wire to its terminal first, followed by the NEGATIVE (Black) wire.

For shipping reasons, both battery cables on your equipment may have been left disconnected from the terminals at the factory. To connect the battery cables, proceed as follows:

NOTE: The positive battery terminal is marked Pos. (+). The negative battery terminal is marked Neg. (-).

1. Remove the plastic cover, if present, from the positive battery terminal and attach the red cable to the positive battery terminal (+) with the bolt (a) and hex nut (b). See Figure 2-2.

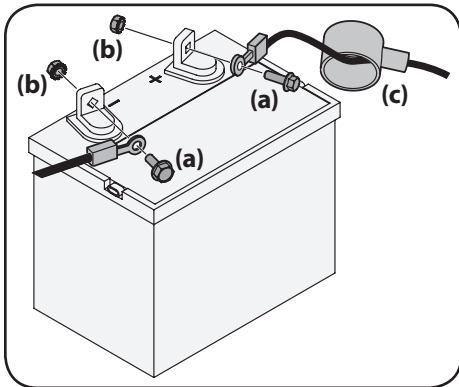

Figure 2-2

2. Remove the plastic cover, if present, from the negative battery terminal and attach the black cable to the negative battery terminal (-) with the bolt (a) and hex nut (b). See Figure 2-2.
3. Position the red rubber boot (c) over the positive battery terminal to help protect it from corrosion.

NOTE: If the battery is put into service after the date shown on top/side of battery, charge the battery as instructed in the Service section your Operator's Manual on page 8 prior to operating the tractor.

Shipping Brace Removal



WARNING! Make sure the tractor's engine is OFF, remove the ignition key, and set the parking brake before removing the shipping brace. Refer to the Controls & Operations section on page 8 for instructions on how to set the parking brake.

4. Check the cutting deck for a shipping brace (a) that may be holding the chute deflector (b) upward for shipment. If the shipping brace (a) is present, it must be removed before operating the tractor. Holding the chute deflector (b) fully upward, remove the shipping brace (a). Lower the chute deflector (b) and discard the shipping brace (a). See Figure 2-3.

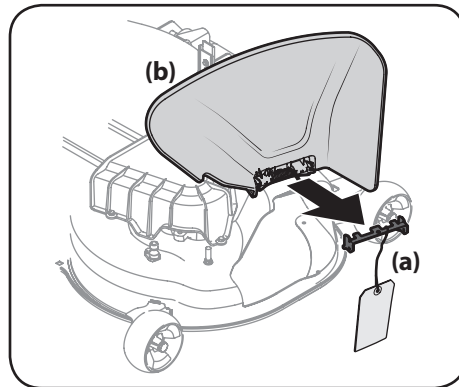

Figure 2-3



WARNING! The shipping brace (a) is used for packaging purposes only, it must be removed and discarded before operating your tractor.



WARNING! The cutting deck is capable of throwing objects. Failure to operate the tractor without the chute deflector in the proper operating position could result in serious personal injury and/or property damage.

Attaching the Steering Wheel

1. If the steering wheel (a) for your tractor did not come attached, the hardware for attaching it has been packed within the steering wheel (a), beneath the steering wheel cap (b). Carefully pry OFF the steering wheel cap (b) and remove the cupped washer (c) and hex bolt (d).

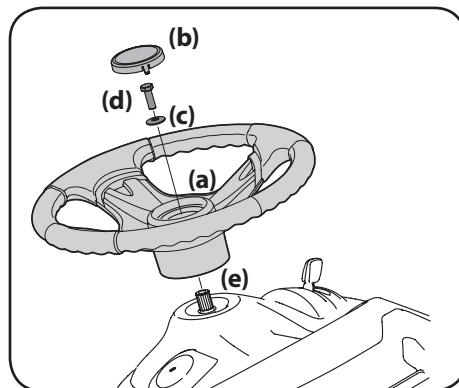

Figure 2-4

2. With the wheels of the tractor pointing straight forward, place the steering wheel (a) over the steering shaft (e).
3. Place the cupped washer (c) -- cupped side down -- over the steering wheel (a) and secure with the hex bolt (d). See Figure 2-4.
4. Place the steering wheel cap (b) over the center of the steering wheel (a) and push downward until it "clicks" into place.

Attaching the Seat

If the seat for your tractor was not attached at the factory, refer to the following steps.

NOTE: For shipping reasons, seats are either fastened to the tractor seat's pivot bracket with a cable tie, or mounted backward to the pivot bracket. In either case, remove the seat from its shipping position.

1. Remove the seat adjustment knob (a) from the bottom of the seat (b). See Figure 2-5.

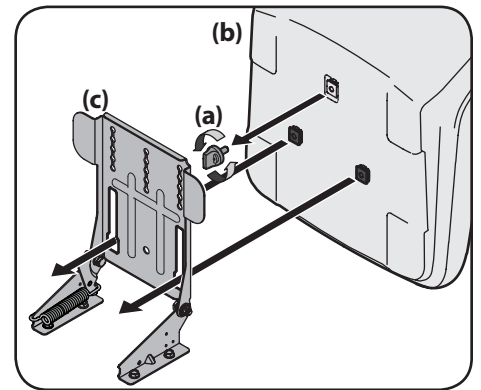

Figure 2-5

2. Align the seat (b) over the seat pivot bracket (c) as shown in Figure 2-5 and fit the seat (b) onto the seat pivot bracket (c) inserting the two tabs on the seat (b) bottom into the slots on the seat pivot bracket (c).
3. Slide the seat (b) rearward in the seat pivot bracket (c), lining up the center rear slot in the seat pivot bracket (c) with the remaining hole in the seat (b) base. See Figure 2-6.

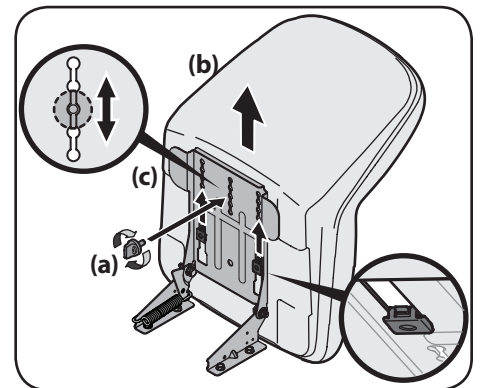

Figure 2-6

NOTE: Be certain the two seat tabs engage the seat pivot bracket as shown in the bottom right inset of Figure 2-6.

4. Select the desired position for the seat (b), and secure with the adjustment knob (a) removed in Step 1. See Figure 2-6.

- To adjust the position of the seat, remove the adjustment knob (a) on the bottom of the seat (b). Slide the seat (b) forward or backward as desired. Reinstall the adjustment knob (a). See Figure 2-6.

Dash Shroud (If Equipped)

There are two shroud types. One shroud for the 1/3/5/K/T-Style and one for the S-Style dash.

Continue below for the 1/3/5/K/T-Style, skip ahead to the S-style section for the S-style dash.

1/3/5/K/T-Style Dash

- If the dash shroud (a) was shipped loose, the hardware for attaching the dash shroud (a) is shipped installed in the dash (c). Remove the two bolts (b) from the dash (c). See Figure 2-7.

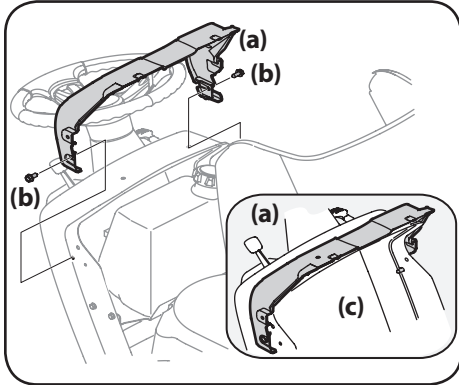

Figure 2-7

- Mount the dash shroud (a) and align the mounting holes. See Figure 2-7.
- Secure the dash shroud (a) to the dash (c) with the bolts (b) removed in Step 1. See Figure 2-7.

S-Style Dash

- If the dash shroud (a) was shipped loose, the hardware for attaching the dash shroud (a) is shipped installed in the dash shroud (a) and the dash (b). Remove the two bolts (c) and washers (d) from the dash (g) and two bolts (e) and clips (f) from the dash shroud (b). See Figure 2-8.

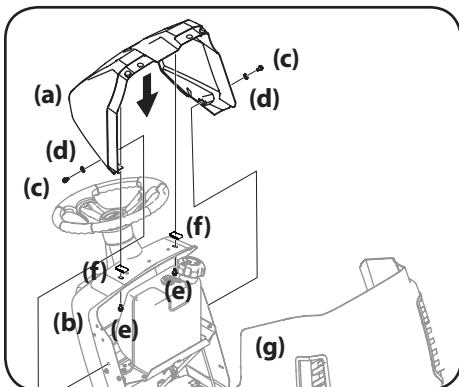

Figure 2-8

- Mount the dash shroud (a) and align the mounting holes. Using the bolts (c/e), washers (d) and clips (f) install the dash shroud (a) and snug the bolts (c) so that the dash shroud (a) can be adjusted.

- Close the hood and align the dash shroud (a) to the hood (g) leaving a uniform gap between the hood (g) and the dash shroud (a).
- Raise the hood (g) and tighten the bolts (c/e) that hold the dash shroud (a) on the dash (b).

Tire Pressure



WARNING! Equal tire pressure should be maintained at all times. Never exceed the maximum inflation pressure shown on the sidewall of the tire.

The recommended operating tire pressure is:

- Approximately 10 psi for the rear tires
- Approximately 14 psi for the front tires

IMPORTANT: Refer to the tire sidewall for exact tire manufacturer's recommended or maximum psi. Do not overinflate. Uneven tire pressure could cause the cutting deck to mow unevenly.

Gas & Oil Fill-up

Oil

IMPORTANT: Your tractor is shipped with motor oil in the engine. However, you **MUST** check the oil level before operating. Be careful not to overfill.

Service and check the engine oil as instructed in the Engine Operator's Manual. Read the instructions carefully.

Gasoline

The gasoline tank is located under the hood. Do not overfill.



WARNING! Use extreme care when handling gasoline. Gasoline is extremely flammable and the vapors are explosive. Never fuel machine indoors or while the engine is hot or running. Extinguish cigarettes, cigars, pipes, and other sources of ignition.

NOTE: Purchase gasoline in small quantities. Do not use gasoline left over from the previous season, to minimize gum deposits in the fuel system.

- This engine is certified to operate on unleaded gasoline. For best results, fill the fuel tank with only clean, fresh, unleaded gasoline with a pump sticker octane rating of 87 or higher.
- Gasohol (up to 10% ethyl alcohol, 90% unleaded gasoline by volume) is an approved fuel. Other gasoline/alcohol blends, such as E85, are not approved.
- Methyl Tertiary Butyl Ether (MTBE) and unleaded gasoline blends (up to a maximum of 15% MTBE by volume) are approved fuels. Other gasoline/ether blends are not approved.
- Fill fuel tank outdoors or in well-ventilated area.
- Never remove gas cap or add fuel while the engine is hot or running. Allow engine to cool at least two minutes before refueling.
- If gasoline is spilled, wipe it off the engine and equipment. Move machine to another area. Wait five minutes before starting the engine.

To Add Gasoline

Refer to Figure 2-1 and proceed to your applicable model for your gas tank.

Hydrostatic Models

- Turn the engine OFF and let the engine cool at least two minutes before removing the fuel cap. The gasoline tank is located under the hood. Remove the fuel cap by turning it counter-clockwise.
- Fill the fuel tank with gasoline. Use only clean, fresh (no more than 30 days old), unleaded gasoline. Fill tank to the base of the filler neck to allow space for fuel expansion. **DO NOT TOP OFF THE TANK WITH FUEL.** See Figure 2-9.

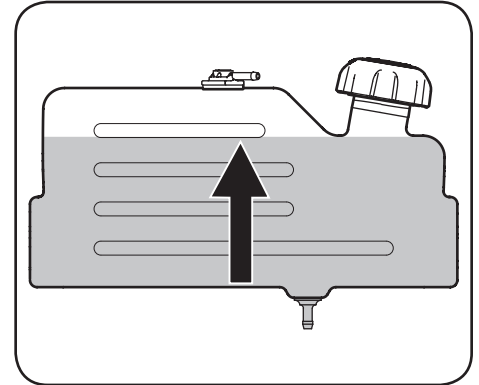

Figure 2-9

- Reinstall the fuel cap.



STOP! Continue to Setting the Deck Gauge Wheels (If Equipped) on page 9.

Foot Control CVT Models & CVT Models

- Turn the engine OFF and let engine cool at least two minutes before removing the fuel cap. The gasoline tank is located under the hood. Remove the fuel cap by turning it counter-clockwise.
- Fill the fuel tank with gasoline. Use only clean, fresh (no more than 30 days old), unleaded gasoline. Fill tank to no more than 1/2" below bottom of filler neck to allow space for fuel expansion. See Figure 2-10.

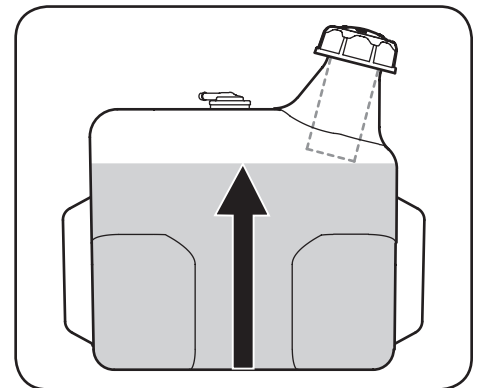

Figure 2-10

- Reinstall the fuel cap.

IMPORTANT: Do not overfill the tank. Fill tank to no more than 1/2" below bottom of

filler neck to allow space for fuel expansion. See Figure 2-10.



STOP! Continue to Setting the Deck Gauge Wheels (If Equipped) on page 10.

Setting the Deck Gauge Wheels (If Equipped)

Move the tractor to a firm and level surface, preferably pavement, and proceed as follows:

1. Select the height position of the cutting deck by placing the deck lift lever in the normally desired mowing height setting (there are six different cutting height notches on the right fender).
2. Check the deck gauge wheels for contact or excessive clearance with the surface below. The deck gauge wheels should have between $\frac{1}{4}$ " and $\frac{1}{2}$ " clearance above the ground.

If the gauge wheels have excessive clearance or contact with the surface, adjust as follows:

- a. Raise the deck lift handle to its highest setting.
- b. Remove the front and rear deck gauge wheels (a) by removing the lock nuts (b) and shoulder screws (c) which secure them to the deck. See Figure 2-11.

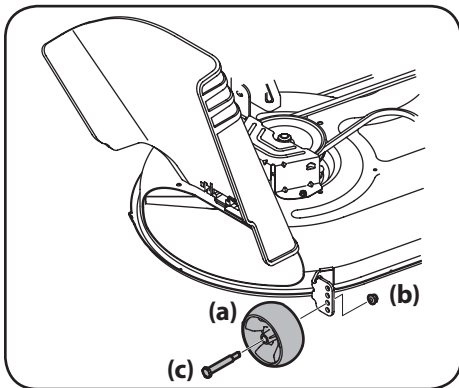

Figure 2-11

- c. Place the deck lift lever in the desired mowing height setting.
- d. Reinsert the shoulder screws (c) into the index hole that leaves approximately $\frac{1}{2}$ " between the bottom of the deck gauge wheel (a) and the pavement. Secure in place with the lock nuts (c).

Refer to Leveling the Deck in the Service section on page 10 of this manual for more detailed instructions regarding various deck adjustments.

Attaching the Hood Scoop (If Equipped)

On some tractors, a hood scoop may be included. If the hood scoop was not installed on the hood of your tractor at the factory, refer to the following steps to install the hood scoop:

1. Cut the cable ties securing the hood scoop to the tractor.
2. Remove the four screws pre-installed in the hood scoop and retain for Step 4.
3. Snap the hood scoop into place using the hood as your guide. See Figure 2-12.

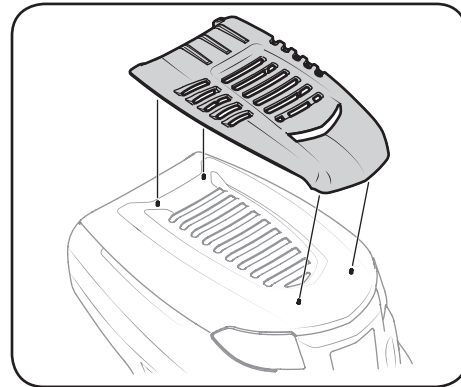

Figure 2-12

4. Install the hood scoop onto the hood of the tractor and secure from the underside using the four screws removed in Step 2.

Moving the Tractor Manually

Refer to Figure 2-1 and proceed to your applicable model.

Hydrostatic Models

Hydrostatic models are equipped with a hydrostatic relief valve when it is necessary to move the tractor manually. Activating this valve forces the fluid in the transmission to bypass its normal route, allowing the rear tires to "freewheel." To engage the hydrostatic relief valve, proceed as follows:

1. Locate the hydrostatic bypass rod in the rear of the tractor. See Figure 2-13.

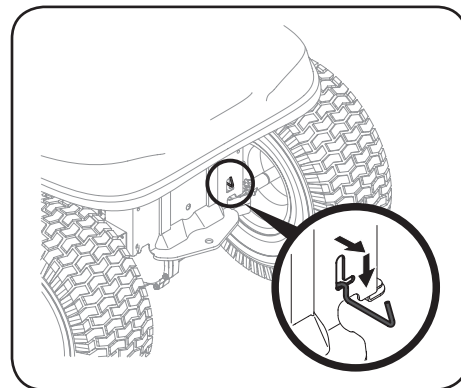

Figure 2-13

2. Pull the hydrostatic bypass rod outward, then down, to lock it in place.

NOTE: The transmission will NOT engage when the hydrostatic bypass rod is pulled out. Return the rod to its normal position prior to operating the tractor.

IMPORTANT: Never attempt to move the tractor manually without first engaging the hydrostatic relief valve. Doing so will result in serious damage to the tractor's transmission.



STOP! Continue to Controls & Operations section page 10.

Foot Control CVT & CVT Models

CVT models can be placed in the NEUTRAL (N) position when it is necessary to move the tractor manually. To move the tractor manually, place the shift lever in the NEUTRAL (N) position.



STOP! Continue to Controls & Operations section page 10.

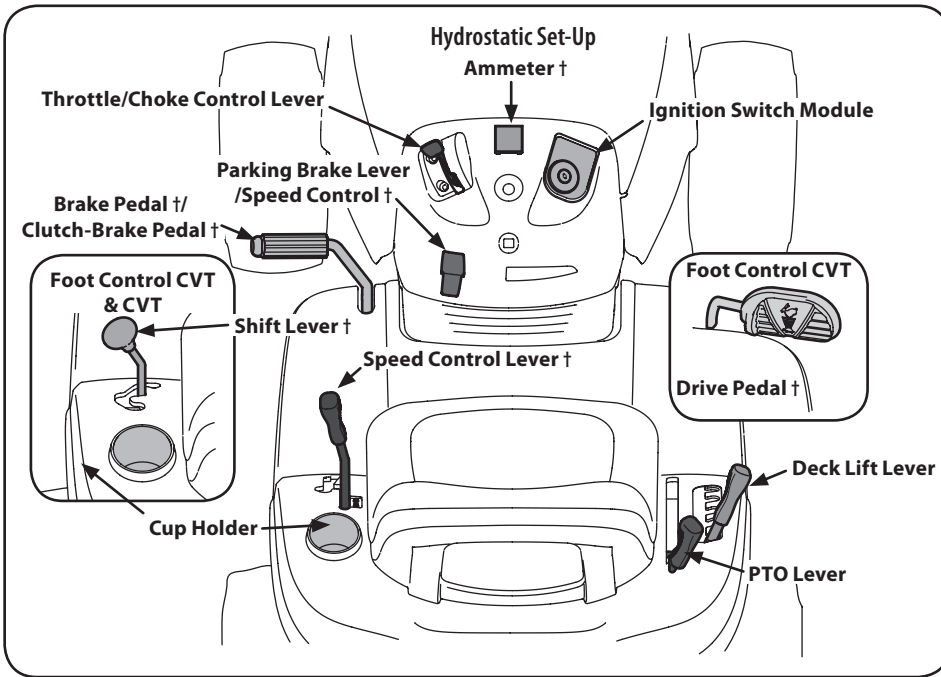

Figure 3-1

Throttle/Choke Control Lever

The throttle/choke control lever is located on the left side of the lawn tractor's dash panel. This lever controls the speed of the engine, as well as the choke when it is pushed all the way forward. When set in a given position, the throttle will maintain a uniform engine speed.

IMPORTANT: When operating the lawn tractor with the cutting deck engaged, be certain that the throttle/choke control lever is always in the FAST (rabbit) position.

Moving the throttle/choke control lever all the way forward activates the engine's choke control. Activating the choke control closes the choke plate on the carburetor and aids in starting the engine.

Refer to Starting the engine on page 13 for detailed starting instructions.

Speed Control Lever

Hydrostatic

The speed control lever, located on the left rear fender, controls the ground speed of the lawn tractor as well as the direction of travel.

To drive forward or in reverse, slowly move the speed control lever to the desired "F" forward or "R" reverse speed.

To stop, move the speed control lever to the "N" neutral position.



When mowing, place the speed control lever in the "Cutting Speed" position, or a slower forward speed for the best results.

NOTE: Do not use the parking brake pedal to control the ground speed of the lawn tractor. Always use the speed control lever to slow the ground speed of the lawn tractor. Depressing the parking brake pedal with the speed control lever engaged as part of regular operation will result in premature wear of the drive belt.

IMPORTANT: Do not attempt to change the direction of travel when the lawn tractor is in motion. Serious damage to the lawn tractor's transmission could result. Always bring the lawn tractor to a complete stop before moving the speed control lever from forward to reverse or vice versa.

CVT

The speed control lever, located on the lower left side of the lawn tractor's dash console, allows you to regulate the ground speed of the lawn tractor.

To use, depress the clutch-brake pedal and move the lever out of the parking brake notch and forward to increase the lawn tractor's ground speed. When a desired speed has been reached, release the lever into an appropriate notch to maintain that speed.

To slow the lawn tractor's ground speed, depress the clutch-brake pedal and move the speed control lever rearward and release it into a notch.

Parking Brake Pedal & Lever (If Equipped)

Hydrostatic & Foot Control CVT

The parking brake pedal is located on the left side running board of the lawn tractor. It is used to set the parking brake and to stop the lawn tractor in sudden situations. The parking brake lever is located on the left side of the lawn tractor's dash panel.

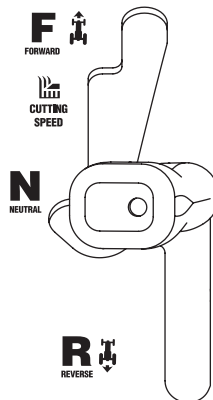

To set the parking brake: Fully depress the parking brake pedal. Move the parking brake lever all the way down and into the parking brake position (PARK BRAKE ON) and then release the brake pedal to allow the parking brake to engage.

To release the parking brake: Depress the brake pedal and the parking brake lever will automatically move out of the parking brake position.

In a sudden situation, fully depress the brake pedal to bring the lawn tractor to a stop and then immediately move the speed control lever to the "N" neutral position.

IMPORTANT: Do not use the parking brake pedal to control the ground speed of the lawn tractor. Doing so will result in premature wear of drive belt. Always use the speed control lever to control the ground speed of the lawn tractor and to stop the lawn tractor under normal circumstances.

NOTE: The parking brake pedal must be depressed to start the engine. The parking brake must also be set if the operator leaves the seat with the engine running or the engine will automatically shut OFF. Refer to Safety Interlock Switches on page 14.

Clutch-Brake Pedal & Parking Brake (If Equipped)

The clutch-brake pedal is located on the left side of the lawn tractor, along the running board. Depress the clutch-brake pedal part way down when slowing the lawn tractor by changing speeds. Refer to Speed Control Lever on page 11. Depress the pedal all the way down to engage the disc brake and bring the lawn tractor to a complete stop.

NOTE: The clutch-brake pedal must be depressed to start the engine. Refer to Safety Interlock Switches on page 12.

To set the parking brake: Fully depress the brake pedal. Move the parking brake lever into the parking brake position. Release the brake pedal to allow the parking brake to engage.

To release the parking brake: Depress the brake pedal and the parking brake lever will move out of the parking brake position. The parking brake will then be released. Release the brake pedal.

NOTE: The parking brake must be set if the operator leaves the seat with the engine running or the engine will automatically shut OFF.

Ammeter (If Equipped)

The ammeter measures the electric current of the engine produced in amperes.

Shift Lever (If Equipped)

Foot Control CVT & CVT

The shift lever is located on the left side of the fender and has three positions; FORWARD (F), NEUTRAL (N) and REVERSE (R). The brake pedal must be depressed and the lawn tractor must not be in motion when moving the shift lever. See Figure 3-2.

IMPORTANT: Never force the shift lever. Doing so may result in serious damage to the lawn tractor's transmission.

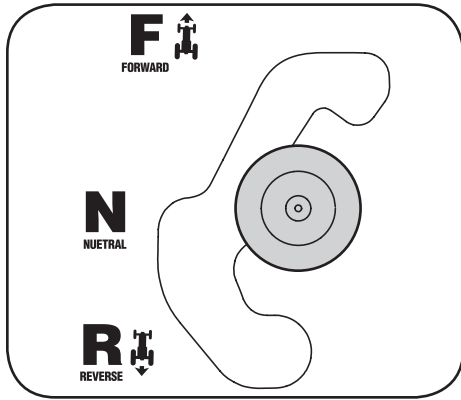

Figure 3-2

Drive Pedal (If Equipped)

Foot Control CVT

The drive pedal is located on the right side of the lawn tractor, along the running board. Depress the drive pedal forward and the lawn tractor will move in the direction that the shift lever is engaged in. To cause the lawn tractor to travel forward, while at a complete stop, move the shift lever into the FORWARD (F) position. Gradually step on the drive pedal and the lawn tractor will begin to move forward. To move in REVERSE (R), follow the same procedure only move the shift lever into the REVERSE (R) position.

The ground speed is controlled with the drive pedal. The further forward that the pedal is pivoted, the faster the lawn tractor will travel. The pedal will return to its original position when it's not depressed. Refer to Driving the Lawn Tractor on page 13 for detailed instructions regarding the drive pedal.

IMPORTANT: Always set the parking brake when leaving the lawn tractor unattended.

Headlights

The headlights are located on the front of the lawn tractor.

- On some models, the lamps are ON when the lawn tractor's engine is running.
- On some models, the lamps are ON whenever the ignition key is moved out of the STOP position.
- On all models, the lamps turn OFF when the ignition key is moved to the STOP position.

Ignition Switch Module

The lawn tractor will have one of the following ignition switches. Refer to Figure 3-3 to identify which switch your machine utilizes and follow the applicable instructions for proper operation.

3-Position Ignition Switch (If Equipped)

The ignition switch is used to start the engine. Insert key into the ignition switch and turn clockwise to the START position. Release the key into the ON position once engine has fired. See Figure 3-3A. The engine will run with the headlights ON.

To stop the engine, turn the key counter-clockwise to the OFF position. See Figure 3-3A.

Ignition Switch Module (If Equipped)

To start the engine, insert the key into the ignition switch and turn clockwise to the START position. Release the key into the NORMAL MOWING MODE position once the engine has fired. The headlights will be activated in the NORMAL (and REVERSE CAUTION MODES).

To stop the engine, turn the key counter-clockwise to the OFF or STOP position. See Figure 3-3B.



WARNING! Never leave a running machine unattended. Always disengage PTO, move shift lever into neutral position, set parking brake, stop engine and remove key to prevent unintended starting.

IMPORTANT: Prior to operating the lawn tractor, refer to both Safety Interlock Switches and Starting The Engine in the Operation section of this manual for detailed instructions regarding the Ignition Switch Module and operating the lawn tractor in REVERSE CAUTION MODE.

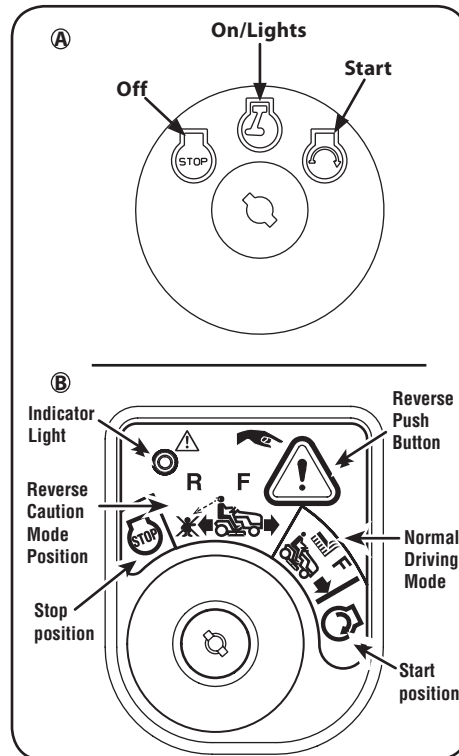

Figure 3-3

Deck Lift Lever

The deck lift lever is located on the lawn tractor's right fender. It is used to change the height of the cutting deck. To use, move the lever to the left, then place in the position best suited for your application.

PTO Lever

The PTO Lever is located on the lawn tractor's right fender. It is used to engage power to the cutting deck or other optional attachments. To operate, move the lever all the way forward. Moving the lever all the way rearward into the PTO OFF position disengages power to the cutting deck or attachment.

NOTE: The PTO lever must be in the disengaged (PTO OFF) position when starting the engine.

Safety Interlock Switches

This lawn tractor is equipped with a safety interlock system for the protection of the operator. If the interlock system malfunctions, do not operate the lawn tractor. Contact an authorized service dealer.

- The safety interlock system prevents the engine from cranking or starting unless the parking brake is engaged, and the PTO lever is in the disengaged (PTO OFF) position.
- The engine will automatically shut OFF if the operator leaves the seat before engaging the parking brake.
- The engine will automatically shut OFF if the operator leaves the lawn tractor's seat with the PTO lever in the engaged (PTO ON) position, regardless of whether the parking brake is engaged.

3-Position Ignition Switch (If Equipped)

- The engine will automatically shut OFF if the PTO lever is moved into the engaged (PTO ON) position with the speed control lever in REVERSE (R) position.

Ignition Switch Module (If Equipped)

- With the ignition key in the NORMAL DRIVING MODE position, the engine will automatically shut OFF if the PTO lever is moved into the engaged (PTO ON) position with the speed control in REVERSE (R) position.



WARNING! Do not operate the lawn tractor if the interlock system is malfunctioning. This system was designed for your safety and protection.

Reverse Caution Mode (If Equipped)



WARNING! Use extreme caution while operating the lawn tractor in the REVERSE CAUTION MODE. Always look down and behind before and during lawn tractor backing. Do not operate the lawn tractor when children or others are around. Stop the lawn tractor immediately if someone enters the area.

The REVERSE CAUTION MODE position of the ignition switch module allows the lawn tractor to be operated in reverse with the blades (PTO) engaged.

IMPORTANT: Mowing in the reverse direction is not recommended.



To use the REVERSE CAUTION MODE:

IMPORTANT: The operator MUST be seated in the lawn tractor seat.

1. Start the engine as instructed on page 13.
2. Turn the key from the NORMAL DRIVING MODE (Green) position to the REVERSE CAUTION MODE (Yellow) position of the ignition switch module. See Figure 3-4.

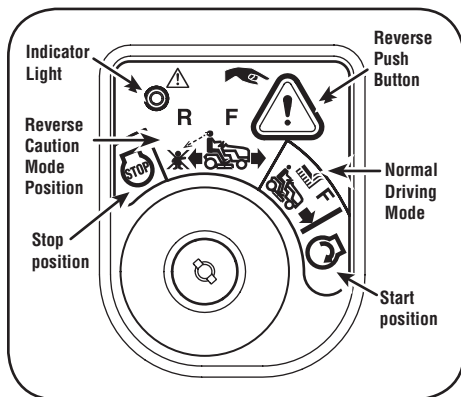

Figure 3-4

3. Depress the REVERSE PUSH BUTTON (Orange, Triangular Button) at the top, right corner of the ignition switch module. The red indicator light at the top, left corner of the ignition switch module will be ON while activated. See Figure 3-4.
4. Once activated (indicator light ON), the lawn tractor can be driven in reverse with the cutting blades (PTO) engaged.
5. Always look down and behind before and while backing to make sure no children are around.
6. After resuming forward motion, return the key to the NORMAL DRIVING MODE position.

IMPORTANT: The REVERSE CAUTION MODE will remain activated until:

- a. The key is placed in either the NORMAL DRIVING MODE position or STOP position.
- b. The operator engages the parking brake by fully depressing the brake pedal and holding it down while moving the parking brake lever into the PARK BRAKE position.

Engaging the Parking Brake

To engage the parking brake:

1. Fully depress the brake pedal/clutch-brake pedal and hold it down with your foot.
2. Move the parking brake lever all the way down and into the ON position.
3. Release the brake pedal/clutch-brake pedal to allow the parking brake to engage.

To release the parking brake:

1. Depress the brake pedal/clutch-brake pedal and move the parking brake lever out of the ON position and into the OFF position.

Setting the Cutting Height

1. Select the height position of the cutting deck by placing the deck lift lever in any of the five different cutting height notches on the right side of the fender.
2. Adjust the deck wheels, if equipped, so that they are between 1/4" and 1/2" above the ground when the lawn tractor is on a smooth, flat surface such as a driveway.



WARNING! Keep hands and feet away from the discharge opening of the cutting deck.

NOTE: On models so equipped, the deck wheels are an anti-scalp feature of the deck and are not designed to support the weight of the cutting deck.

Refer to Leveling the Deck on page 17 for more detailed instructions regarding various deck adjustments.

Starting the Engine



WARNING! Do not operate the lawn tractor if the interlock system is malfunctioning. This system was designed for your safety and protection.

NOTE: Refer to Gas & Oil fill-up instructions on page 9.

1. Insert the key into the ignition switch.
2. Place the PTO lever in the disengaged (PTO OFF) position.
3. Engage the lawn tractor's parking brake (if equipped).
4. Activate the choke control.
5. Turn the key clockwise to the START position. After the engine starts, release the key. It will return to the PTO ON (or NORMAL DRIVING MODE) position.

IMPORTANT: Do NOT hold the key in the START position for longer than 10 seconds at a time. Doing so may cause damage to your engine's electric starter.

6. After the engine starts, deactivate the throttle/choke control lever and place the throttle/choke control lever in the FAST position.

NOTE: Do NOT leave the choke control on while operating the lawn tractor. Doing so will result in a "rich" fuel mixture and cause the engine to run poorly.

Stopping the Engine



WARNING! If you strike a foreign object, stop the engine, disconnect the spark plug wire(s) and ground against the engine. Thoroughly inspect the machine for any damage. Repair the damage before restarting and operating.

1. If the blades are engaged, place the PTO lever in the disengaged (OFF) position.
2. Turn the key counter-clockwise to the STOP position.
3. Remove the key from the ignition switch to prevent unintended starting.

Driving the Lawn Tractor



WARNING! Always look down and behind before and while traveling in reverse to avoid a back-over accident.



WARNING! Before leaving the operator's position, place the PTO lever in the disengaged (PTO OFF) position, place speed control lever in NEUTRAL (N), set parking brake, stop engine and remove key to prevent unintended starting. Depress the parking brake pedal to release the parking brake and let the pedal up.

Hydrostatic

1. Move the throttle lever into the FAST (rabbit) position.

NOTE: Always operate the lawn tractor with the throttle control lever in the FAST (rabbit) position for the most efficient use of the cutting deck or other (separately available) attachments.

2. Depress the parking brake pedal to release the parking brake.
3. Slowly move the speed control lever in desired FORWARD (F) or REVERSE (R) position. The further forward or rearward that the lever is moved, the faster the lawn tractor will travel.



WARNING! Do NOT attempt to change the direction of travel when the lawn tractor is in motion. Always bring the lawn tractor to a complete stop before moving the speed control lever from forward to reverse or vice versa. Failure to do so could result in serious damage to your lawn tractor's transmission.

IMPORTANT: First-time operators should use slower speeds. Become completely familiar with the lawn tractor's operation and controls before operating the lawn tractor at higher speed.

4. To stop, move the speed control lever to the NEUTRAL (N) position.

IMPORTANT: In a sudden situation, fully depress the brake pedal to bring the lawn tractor to a stop and then immediately move the speed control lever to the "N" neutral position.

5. Set the parking brake by fully depressing the parking brake pedal and keeping it depressed while placing the parking brake lever in the ON position. Release the parking brake pedal to allow the parking brake to engage.



WARNING! Before leaving the operator's position for any reason, disengage the blades, place the speed control lever in neutral, engage the parking brake, shut engine OFF and remove the key.

Parking the Lawn Tractor

IMPORTANT: When stopping the lawn tractor for any reason while on a grass surface:

1. Place the speed control lever in N (neutral),
2. Engage the parking brake.
3. Shut engine OFF and remove the key. Doing so will minimize the possibility of having your lawn "browned" by hot exhaust from your lawn tractor's running engine.

CVT

1. Depress the clutch-brake pedal to release the parking brake and let the pedal up.
2. Move the throttle lever into the FAST (rabbit) position.
3. Place the shift lever in either the FORWARD (F) or REVERSE (R) position.



CAUTION: Do NOT use the shift lever to change the direction of travel when the lawn tractor is in motion. Always use the clutch-brake pedal to bring the lawn tractor to a complete stop before shifting.

4. Release the parking brake by depressing the clutch-brake pedal and positioning the speed control lever in desired position.

IMPORTANT: First-time operators should use speed positions 1 or 2. Become completely familiar with the lawn tractor's operation and controls before operating the lawn tractor in higher speed positions.

5. Release clutch-brake pedal slowly to put unit into motion.
6. The lawn tractor is brought to a stop by depressing the clutch-brake pedal.

NOTE: When operating the unit initially, there will be little difference between the highest two speeds until after the belts have seated themselves into the pulleys during the break-in period.



WARNING! Before leaving the operator's position for any reason, disengage the blades, place the shift lever in neutral, engage the parking brake, shut engine OFF and remove the key.

If unit stalls with speed control in high speed, or if unit will not operate with speed control lever in a low speed position, proceed as follows:

1. Place shift lever in NEUTRAL (N).
2. Restart engine.
3. Place speed control lever in highest speed position.
4. Release clutch-brake pedal fully.
5. Depress clutch-brake pedal.
6. Place speed control lever in desired position.
7. Place shift lever in either FORWARD (F) or REVERSE (R), and follow normal operating procedures.

Parking the Lawn Tractor

IMPORTANT: When stopping the lawn tractor for any reason while on a grass surface:

1. Place the shift lever in NEUTRAL (N).
2. Engage the parking brake.
3. Shut engine OFF and remove the key. Doing so will minimize the possibility of having your lawn "browned" by hot exhaust from your lawn tractor's running engine.

Foot Control CVT

1. Depress the brake pedal to release the parking brake and let the pedal up.
2. Move the throttle lever into the FAST (rabbit) position.
3. Place the shift lever in either the FORWARD (F) or REVERSE (R) position.



CAUTION: Do NOT use the shift lever to change the direction of travel when the lawn tractor is in motion. Always use the brake pedal to bring the lawn tractor to a complete stop before shifting.

IMPORTANT: First-time operators should become completely familiar with the lawn tractor's operation and controls before operating the lawn tractor in higher speed positions.

4. Gradually begin to apply pressure to the drive pedal. The further down the pedal is pushed, the faster the lawn tractor will travel in the desired direction based on the position of the shift lever.
5. The lawn tractor is brought to a stop by releasing the drive pedal and then depressing the brake pedal.



WARNING! Before leaving the operator's position for any reason, disengage the blades, place the shift lever in NEUTRAL (N), engage the parking brake, shut engine OFF and remove the key.

Parking the Lawn Tractor

IMPORTANT: When stopping the lawn tractor for any reason while on a grass surface:

1. Place the shift lever in NEUTRAL (N).
2. Engage the parking brake.
3. Shut engine OFF and remove the key. Doing so will minimize the possibility of having your lawn "browned" by hot exhaust from your lawn tractor's running engine.

Driving On Slopes

Refer to the SLOPE GAUGE on page 6 to help determine slopes where you may operate the lawn tractor safely.



WARNING! Do not mow on inclines with a slope in excess of 15 degrees (a rise of approximately 2-½ feet every 10 feet). The lawn tractor could overturn and cause serious injury.

- Mow up and down slopes, NEVER across.
- Exercise extreme caution when changing direction on slopes.
- Watch for holes, ruts, bumps, rocks, or other hidden objects. Uneven terrain could overturn the machine. Tall grass can hide obstacles.
- Avoid turns when driving on a slope. If a turn must be made, turn down the slope. Turning up a slope greatly increases the chance of a roll over.
- Avoid stopping when driving up a slope. If it is necessary to stop while driving up a slope, start up smoothly and carefully to reduce the possibility of flipping the lawn tractor over backward.

Engaging the Blades

Engaging the PTO (*blade engage*) transfers power to the cutting deck. To engage the blades, proceed as follows:

1. Move the throttle control lever to the FAST (rabbit) position.
2. Grasp the PTO lever and pivot it all the way forward into the engaged (PTO ON) position.
3. Keep the throttle lever in the FAST (rabbit) position for the most efficient use of the cutting deck or other optional attachments.

IMPORTANT: Models with REVERSE CAUTION MODE: The engine will automatically shut OFF if the PTO is engaged with the speed control lever in position for reverse travel with the key in the NORMAL DRIVING MODE position.

IMPORTANT: Models without REVERSE CAUTION MODE: The PTO lever must be in the disengaged (PTO OFF) position when starting the engine, when traveling in reverse, and if the operator leaves the seat. Refer to Safety Interlock Switches on page 12.

Using the Deck Lift Lever

To raise the cutting deck, move the deck lift lever to the left, then place it in the notch best suited for your application. Refer to Setting The Cutting Height on page 13.

Mowing



WARNING! To help avoid blade contact or a thrown object injury, keep bystanders, helpers, children and pets at least 75 feet from the machine while it is in operation. Stop machine if anyone enters the area.

The following information will be helpful when using the cutting deck with your lawn tractor:



WARNING! Plan your mowing pattern to avoid discharge of materials toward roads, sidewalks, bystanders and the like. Also, avoid discharging material against a wall or obstruction which may cause discharged material to ricochet back toward the operator.

- Do not mow at high ground speed, especially if a mulch kit or grass collector is installed.
- For best results it is recommended that the first two laps be cut with the discharge thrown towards the center. After the first two laps, reverse the direction to throw the discharge to the outside for the balance of cutting. This will give a better appearance to the lawn.
- Do not cut the grass too short. Short grass invites weed growth and yellows quickly in dry weather.
- Mowing should always be done with the engine at full throttle.
- Under heavier conditions it may be necessary to go back over the cut area a second time to get a clean cut.
- Do NOT attempt to mow heavy brush and weeds and extremely tall grass. Your lawn tractor is designed to mow lawns, NOT clear brush.
- Keep the blades sharp and replace the blades when worn. Refer to Cutting Blades on page 18 for proper blade sharpening instructions.

Maintenance Schedule

	Before Each use	Every 10 Hours	Every 25 Hours	Every 50 Hours	Every 100 Hours	Prior to Storing
Clean Hood/Dash Louvers		✓				✓
Clean Battery Terminals		✓				✓
Lube Front Axles and Rims			✓			✓
Clean Engine Cooling Fins			✓			✓
Lube Pedal Pivot Points		✓				✓

IMPORTANT: It is important to consult the specific Engine Operator's Manual included with this machine for detailed engine maintenance procedures and intervals.



WARNING: Before performing any maintenance or repairs, disengage PTO, move shift lever into neutral position, set parking brake, stop engine and remove key to prevent unintended starting.

Engine

Refer to the Engine Operator's Manual for engine maintenance instructions.

Check engine oil level before each use as instructed in the Engine Operator's Manual. Follow the instructions carefully.

Changing Engine Oil

Oil Drain Hose Models



WARNING! If the engine has been recently run, the engine, muffler and surrounding metal surfaces will be hot and can cause burns to the skin. Exercise caution to avoid burns.

NOTE: The oil filter (if equipped) should be changed at every oil change interval.

To complete the oil change, proceed as follows:

1. Run the engine for a few minutes to allow the oil in the crankcase to warm. Warm oil will flow more freely and carry away more of the engine sediment which may have settled at the bottom of the crankcase. Use care to avoid burns from hot oil.
2. Open the tractor's hood and locate the oil drain port on the left side of the engine.

3. Open the protective cap on the end of the oil drain valve to expose the drain port. See inset of Figure 4-1.

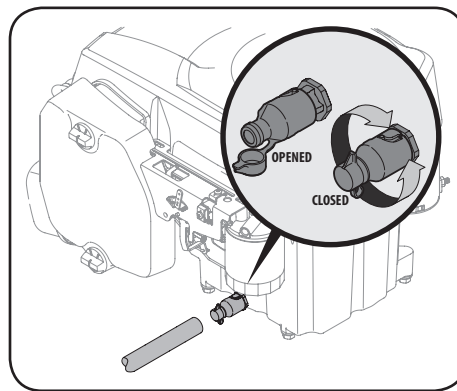

Figure 4-1

4. Remove the oil fill cap/dipstick from the oil fill tube.
5. Push the oil drain hose (provided) onto the oil drain port. Route the opposite end of the hose into an appropriate oil collection container with at least a 2.5 quart capacity, to collect the used oil.
6. Slightly push in on the oil drain valve and rotate counter-clockwise to open and allow the flow of oil. See Figure 4-1.
7. After the oil has finished draining, push the oil drain valve back in and rotate into the locked position. Re-cap the end of the oil drain valve to keep debris from entering the drain port.
8. Replace the oil filter (if equipped) as instructed in the Engine Operator's Manual.
9. Refill the engine with new oil. Refer to the Engine Operator's Manual for information regarding the proper quantity and viscosity of engine oil.

Oil Drain Sleeve Models



WARNING! If the engine has been recently run, the engine, muffler and surrounding metal surfaces will be hot and can cause burns to the skin. Exercise caution to avoid burns.

To complete the oil change, proceed as follows:

1. Run the engine for a few minutes to allow the oil in the crankcase to warm. Warm oil will flow more freely and carry away more of the engine sediment which may have settled at the bottom of the crankcase. Use care to avoid burns from hot oil.
2. Open the tractor's hood and locate the oil drain port on the left side of the engine.
3. Unscrew the oil fill cap and remove the dipstick from the oil fill tube.
4. Snap the small end of oil drain sleeve onto the oil sump. See Figure 4-2.

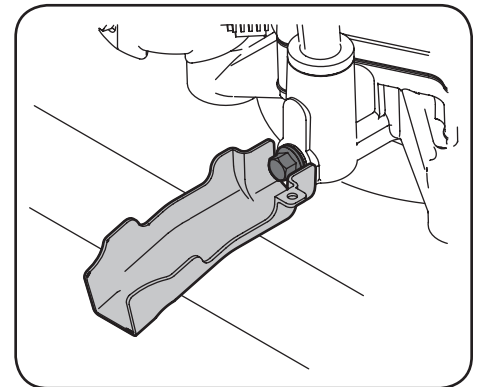

Figure 4-2

5. Remove drain plug and drain oil into a suitable container with a capacity of no less than 64 oz.
6. Service oil filter (if equipped) as instructed in the separate Engine Operator's Manual.
7. Perform the previous steps in the opposite order after oil has finished draining.
8. Refill the engine with new oil. Refer to the Engine Operator's Manual for information regarding the proper quantity and viscosity of engine oil.

Lubrication



WARNING! Before lubricating, repairing, or inspecting, always disengage PTO, move shift lever into neutral position, set parking brake, stop engine and remove key to prevent unintended starting.

Engine

Lubricate the engine with motor oil as instructed in the Engine Operator's Manual.

Pivot Points & Linkage

Lubricate all the pivot points on the drive system, parking brake and deck lift linkage at least once a season with light oil.

Rear Wheels

The rear wheels should be removed from the axles once a season. Lubricate the axles and the rims with an all-purpose grease before re-installing them.

Front Axles (Hydrostatic only)

Each end of the tractor's front pivot bar may be equipped with a grease fitting. Lubricate with a grease gun after every 25 hours of tractor operation.

Headlights

Refer to the Parts/Warranty Supplement when replacement of head lamp bulbs is necessary.

Replace headlight bulbs as follows:

1. Fully raise the hood of the tractor.
2. Unplug the wire harness leads from the headlight socket terminals. Note which wire connects to each terminal before disconnecting.
3. Rotate the socket assembly approximately a ¼-turn to align the socket tab with the reflector housing notch; then withdraw the bulb and socket assembly from the reflector housing. See Figure 4-3.

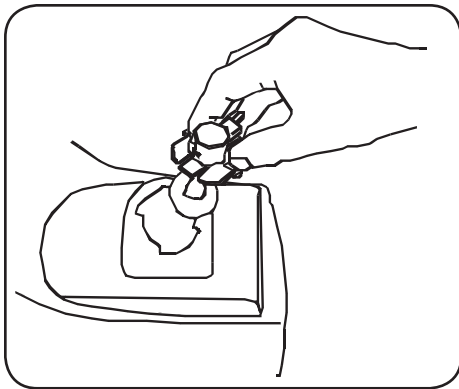

Figure 4-3

4. Push the bulb inward and turn counter-clockwise to remove from the socket.
5. Align a locking post of the bulb base with the notch in the socket, then push the bulb inward and turn clockwise to lock. See Figure 4-3.
6. Align the socket tab with the notch of the reflector housing; then push the socket inward and turn as necessary to lock the socket in the housing.
7. Connect the wire harness leads to the appropriate socket terminals.

Cleaning the Engine & Deck

Engine

Any fuel or oil spilled on the machine should be wiped off promptly. Do NOT allow debris to accumulate around the cooling fins of the engine or on any other part of the machine.

IMPORTANT: The use of a pressure washer to clean your tractor is NOT recommended. It may cause damage to electrical components, spindles, pulleys, bearings or the engine.

Deck Wash System™ (If Equipped)

Some tractors come fitted with a Deck Wash System™, which is used to rinse grass clippings from the deck's underside and prevent the buildup of corrosive chemicals. Other tractors may have a deck wash plug, allowing for a Deck Wash System™ that can be added at a later time. If this is the case, a hex bolt and washer can be found on your tractor's deck surface and can be replaced with a water port to be used as part of an optional deck wash system.

To utilize the Deck Wash System™, complete the following steps AFTER EACH MOWING:

1. Drive the tractor to a level, clear spot on your lawn, near enough for your garden hose to reach.



CAUTION: Make certain the tractor's discharge chute is directed AWAY from your house, garage, parked cars, etc.

2. Disengage the PTO (PTO OFF), set the parking brake and stop the engine.
3. Thread the hose coupler (packaged with your Operator's Manual) onto the end of your garden hose.
4. Attach the hose coupler to the water port on the deck's surface. See Figure 4-4.

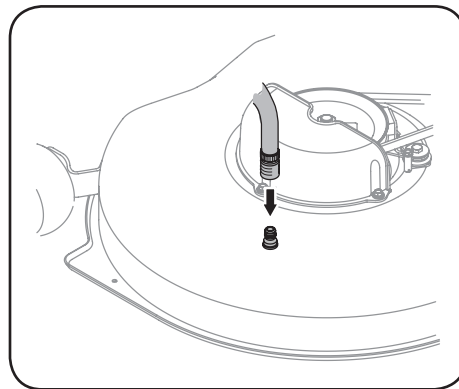

Figure 4-4

5. Turn the water ON.
6. While sitting in the operator's position on the tractor, start the engine and place the throttle lever in the FAST (rabbit) position.
7. Move the tractor's PTO into the PTO ON position.
8. Remain in the operator's position with the cutting deck engaged for a minimum of two minutes, allowing the underside of the cutting deck to thoroughly rinse.
9. Move the tractor's PTO into the PTO OFF position.
10. Turn the key to the STOP position to turn the lawn tractor's engine OFF.

11. Turn the water OFF and detach the hose coupler from the water port on your deck's surface.
12. Repeat steps 4 through 11 on the opposite side of the cutting deck if a second water port is present.

IMPORTANT: After cleaning your deck with the Deck Wash System™, return to the operator's position and engage the PTO. Keep the cutting deck running for a minimum of two minutes, allowing the underside of the cutting deck to thoroughly dry.

Battery



CALIFORNIA PROPOSITION 65 WARNING! Battery posts, terminals, and related accessories contain lead and lead compounds, chemicals known to the State of California to cause cancer and reproductive harm. Wash hands after handling.



CAUTION: If removing the battery, disconnect the NEGATIVE (Black) wire from its terminal first, followed by the POSITIVE (Red) wire. When re-installing the battery, always connect the POSITIVE (Red) wire its terminal first, followed by the NEGATIVE (Black) wire.

The battery is sealed and is maintenance-free. Acid levels cannot be checked.

- Always keep the battery cables and terminals clean and free of corrosive build-up.
- After cleaning the battery and terminals, apply a light coat of petroleum jelly or grease to both terminals.
- Always keep the rubber boot positioned over the positive terminal to prevent shorting.

IMPORTANT: Be certain that the wires are connected to the correct terminals; reversing them could change the polarity and result in damage to your engine's alternating system.

Cleaning Battery

Clean the battery by removing it from the tractor and washing with a baking soda and water solution. If necessary, clean the battery terminals with a wire brush to remove deposits. Coat terminals and exposed wiring with a light coat of petroleum jelly or grease to both terminals prevent corrosion.

Battery Failures

Some common causes for battery failure are:

- Incorrect initial activation
- Overcharging
- Freezing
- Undercharging
- Corroded connections

NOTE: These failures are NOT covered by your tractor's warranty.

Charging



WARNING! Batteries emit an explosive gas while charging. Charge the battery in a well ventilated area and keep away from an open flame or pilot light as on a water heater, space heater, furnace, clothes dryer or other gas appliances.



CAUTION: When charging your tractor's battery, use only a charger designed for 12V lead-acid batteries. Read your battery charger's Owner's Manual prior to charging your tractor's battery. Always follow its instructions and heed its warnings.

If your tractor has not been put into use for an extended period of time, charge the battery as follows:

Set your battery charger to deliver a max of 10A. If your battery charger is automatic, charge the battery until the charger indicates that charging is complete. If the charger is not automatic, charge for a minimum of eight hours.

Jump Starting



WARNING! Never jump start a damaged or frozen battery. Be certain the vehicles do not touch, and ignitions are OFF. Do not allow cable clamps to touch.

IMPORTANT: Never jump start your lawn tractor's battery with the battery of a running vehicle.

1. Connect positive (+) cable to positive post (+) of your lawn tractor's discharged battery.
2. Connect the other end of the cable to the (positive +) post of the jumper battery.
3. Connect the second cable (negative -) to the other post of the jumper battery.
4. Make the final connection on the engine block of the tractor, away from the battery. Attach to a unpainted part to ensure a good connection.



CAUTION: If the jumper battery is installed on a vehicle (i.e. car, truck), do NOT start the vehicle's engine when jump starting your lawn tractor.

5. Start the tractor as instructed on page 13.
6. Set the tractor's parking brake before removing the jumper cables, in reverse order of connection.



WARNING! Failure to properly jump start the battery could cause a spark, and the gas in either battery could explode.

Removing the Battery

To remove the battery, pull outward and then up on the battery hold-down bracket. See Figure 4-5.

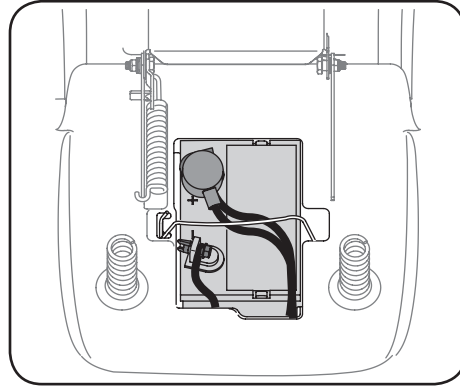

Figure 4-5

Fuse

One 20A fuse is installed in your tractor's wiring harness to protect the tractor's electrical system from damage caused by excessive amperage.

If the electrical system does not function, or your tractor's engine will not crank, check that the fuse has not blown. It can be found at the rear of the unit, underneath the fender located by the battery.



WARNING! Always use a fuse with the same amperage capacity for replacement.

Leveling the Deck

NOTE: Check the tractor's tire pressure before performing any deck leveling adjustments. Refer to Tires on page 18 for more information regarding tire pressure.

Front-to- Rear

The front of the cutting deck is supported by a stabilizer bar that can be adjusted to level the deck from front to rear. The front of the deck should be between $\frac{1}{4}$ " and $\frac{3}{8}$ " lower than the rear of the deck. Adjust if necessary as follows:

1. With the tractor parked on a firm, level surface, place the lever for lifting the platform on the second to the top notch (second highest position) and rotate the blade as close to the discharge channel that is parallel to the tractor.
2. Measure the distance from the front of the blade tip to the ground and the rear of the blade tip to the ground. The first measurement taken should be between $\frac{1}{4}$ " and $\frac{3}{8}$ " less than the second measurement. Determine the approximate distance necessary for proper adjustment and proceed, if necessary, to the next step.

3. Locate the jam nut and lock nut on the front side of the stabilizer bracket. See Figure 4-6

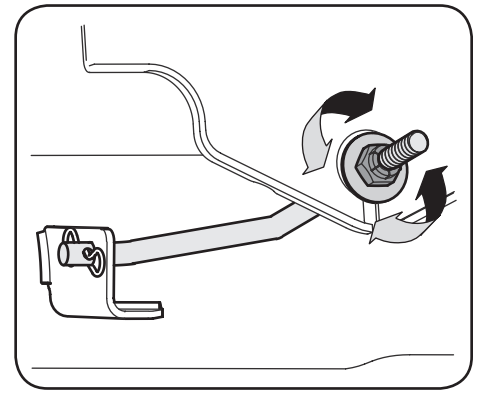

Figure 4-6

4. After loosening the jam nut:
 - Tighten the lock nut to raise the front of the deck;
 - Loosen the lock nut to lower the front of the deck.
4. Retighten the jam nut loosened earlier when proper adjustment is achieved.

Side-to-Side

If the cutting deck appears to be mowing unevenly, a side-to-side adjustment can be performed. Adjust if necessary as follows:

1. With the tractor parked on a firm, level surface, place the deck lift lever in the second notch from the top (second highest position) and rotate both blades so that they are perpendicular with the tractor.
2. Measure the distance from the outside of the left blade tip to the ground and the distance from the outside of the right blade tip to the ground. Both measurements taken should be equal. If they're not, proceed to the next step.
3. Loosen, but do NOT remove, the hex cap screw on the left deck hanger bracket. See Figure 4-7.

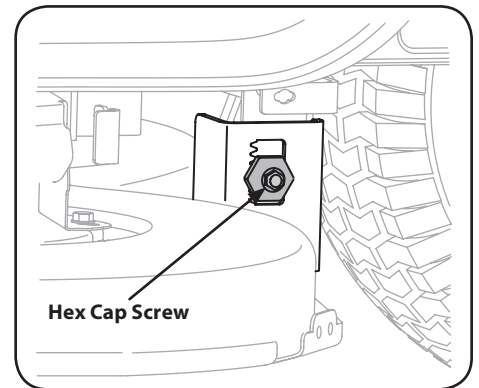

Figure 4-7

4. Balance the deck by using a wrench to turn the adjustment gear (found immediately behind the hex cap screw just loosened) clockwise/up or counter-clockwise/down. The deck is properly balanced when both blade tip measurements taken earlier are equal.
5. Retighten the hex cap screw on the left deck hanger bracket when proper adjustment is achieved.

Seat Adjustment

Refer to Attaching the Seat in page 8 for seat adjustment instructions.

Parking Brake Adjustment



WARNING! Never attempt to adjust the brakes while the engine is running. Always disengage PTO, move shift lever into neutral position, stop engine and remove key to prevent unintended starting.

If the tractor does not come to a complete stop when the brake pedal is completely depressed, or if the tractor's rear wheels can roll with the parking brake applied, the brake is in need of adjustment. See an authorized service dealer to have your brakes properly adjusted.

Cutting Deck Removal

To remove the cutting deck, proceed as follows:

1. Place the PTO lever in the disengaged (OFF) position and engage the parking brake.
2. Lower the deck by moving the deck lift lever into the bottom notch on the right fender.
3. Remove the belt-keeper rod, from around the tractor's engine pulley, by removing the self-tapping screw (A) that secures it. See Figure 4-8.

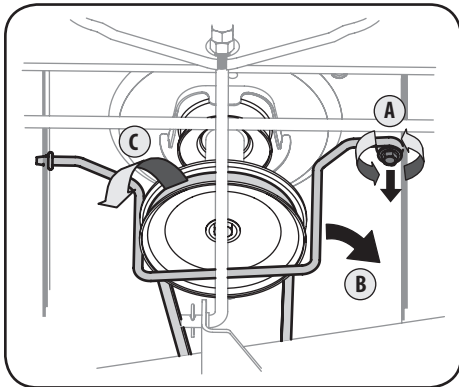

Figure 4-8

NOTE: Make a note what hole the other end of the belt-keeper rod is inserted in for reinstallation purposes.

4. Remove the belt (C) from around the tractor's engine pulley and idler pulley(s). See Figure 4-8.

5. Looking at the cutting deck from the left side of the tractor, locate the bow-tie pin that secures the deck support rod on the rear left side of the deck. See Figure 4-9. Remove the bow-tie pin that secures the deck support rod, and carefully remove the deck support from the deck lift arm.

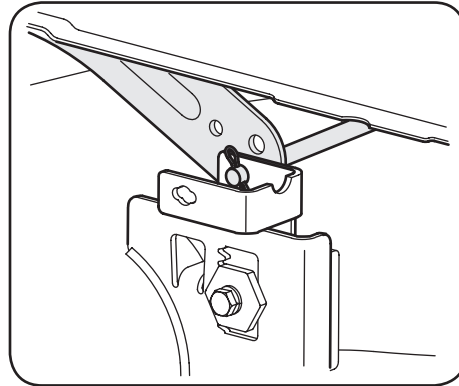

Figure 4-9

6. Repeat step 5 on the tractor's right side.
7. Move the deck lift lever into the top notch on the right fender to raise the deck lift arms up and out of the way.
8. Remove the bow-tie pin securing the deck stabilizer rod to the deck. Slide the deck lift rod from the mounting weldment on the deck as seen in Figure 4-10.

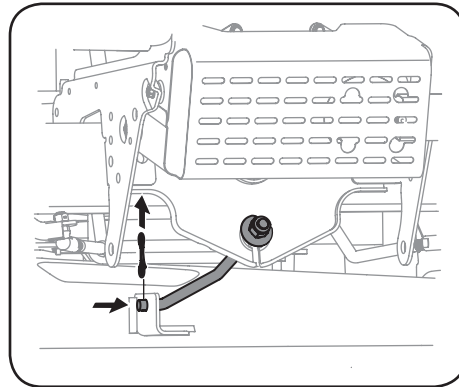

Figure 4-10

9. Carefully remove the PTO cable from the rear of the cutting deck by removing the bow-tie clip which secures it. Remove the spring from the deck idler bracket. See Figure 4-11.

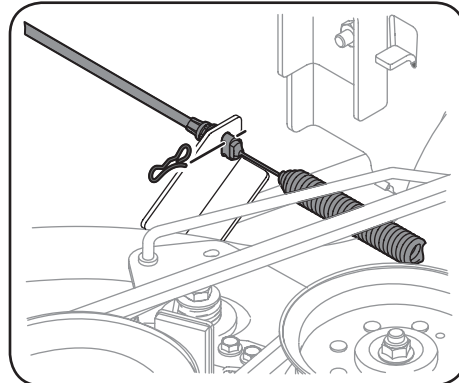

Figure 4-11

10. Gently slide the cutting deck (from the left side) out from underneath the tractor.

Tires



WARNING! Never exceed the maximum inflation pressure shown on the sidewall of the tire.

The recommended operating tire pressure is:

- Approximately 10 psi for the rear tires
- Approximately 14 psi for the front tires

IMPORTANT: Refer to the tire sidewall for exact tire manufacturer's recommended or maximum psi. Do not overinflate. Uneven tire pressure could cause the cutting deck to mow unevenly.

Cutting Blades



WARNING! Shut the engine OFF and remove the key before removing the cutting blade(s) for sharpening or replacement. Protect your hands by using heavy gloves when grasping the blade.



WARNING! Periodically inspect the blade spindles for cracks or damage, especially if you strike a foreign object. Replace immediately if damaged.

The blades may be removed as follows:

1. Remove the deck from beneath the tractor, (refer to Cutting Deck Removal on page 18) then gently flip the deck over to expose its underside.
2. Place a block of wood between the center deck housing baffle and the cutting blade to act as a stabilizer. See Figure 4-12.
3. Remove the hex flange nut that secures the blade to the spindle assembly. See Figure 4-12.

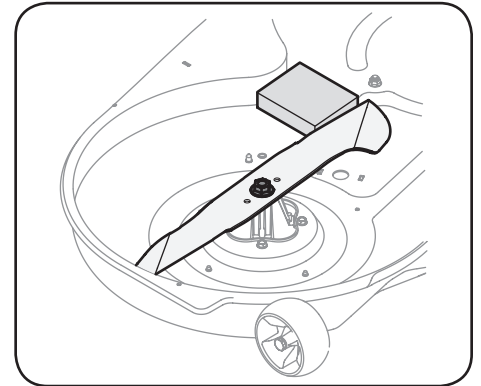

Figure 4-12

4. To properly sharpen the cutting blades, remove equal amounts of metal from both ends of the blades along the cutting edges, parallel to the trailing edge, at a 25° to 30° angle.

IMPORTANT: If the cutting edge of the blade has already been sharpened to within 1-5/8" from the edge, or if any metal separation is present, replace the blades with new ones. See Figure 4-13.

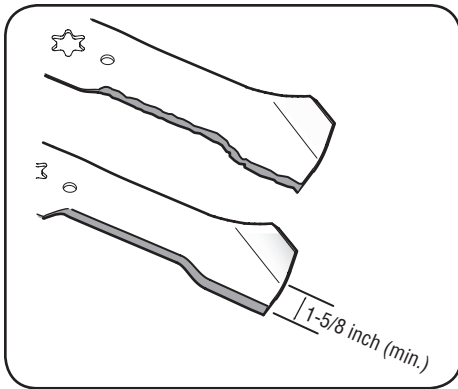

Figure 4-13



CAUTION: If the cutting edge of the blade has previously been sharpened, or if any metal separation is present, replace the blades with new ones.



WARNING! A poorly balanced blade will cause excessive vibration, may cause damage to the tractor and/or result in personal injury.

5. Test the blade's balance using a blade balancer. Grind metal from the heavy side until it balances evenly.

NOTE: When replacing the blade, be sure to install the blade with the side of the blade marked "Bottom" (or with a part number stamped in it) facing the ground when the mower is in the operating position.



CAUTION: Use a torque wrench to tighten the blade spindle hex flange nut to between 70 ft-lbs and 90 ft-lbs.

Changing the Deck Belt



WARNING! Be sure to shut the engine OFF, remove the key, disconnect the spark plug wire(s) and ground against the engine to prevent unintended starting before removing the belt.



WARNING! All belts on your lawn tractor are subject to wear and should be replaced if any signs of wear are present.

IMPORTANT: The V-belt found on your tractor are specially designed to engage and disengage safely. A substitute (non-OEM) V-belt can be dangerous by not disengaging completely. For a proper working machine, use factory approved belts.

To change or replace the deck belt on your tractor, proceed as follows:

1. Remove the deck. Refer to Cutting Deck Removal on page 18.

2. Remove the belt covers by removing the hex washer screws that fasten them to the deck. See Figure 4-14.

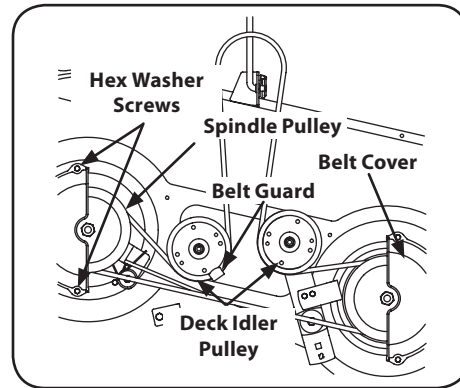

Figure 4-14

3. It may also be necessary to loosen the hex nut on the left idler pulley to get the belt off the pulley and around the belt guard.
4. Carefully remove the deck belt from around the two spindle pulleys and the two deck idler pulleys. See Figure 4-14.
5. To place the new belt, begin by routing the belt around the two outer spindle pulleys as shown in Figure 4-14.
6. Route the belt around the two deck idler pulleys as shown in Figure 4-14.
7. Retighten the left idler pulley hex nut loosened in step 3.
8. Remount the belt covers removed in Step 2.
9. Re-install the deck, making sure the belt remains routed around the pulleys as instructed. See Figure 4-14.
10. Pull the right side of the belt, and place the narrow V side of the belt into the PTO pulley.
11. While holding the belt and pulley together, rotate the pulley to the left. Continue holding and rotating the pulley and belt until the belt is fully rolled into the PTO pulley.

Changing the Transmission Drive Belt

NOTE: Several components must be removed and special tools (i.e. air/impact wrench) are needed in order to change the tractor's drive belt. See an authorized Service Dealer to have your drive belt replaced.

Problem	Cause	Remedy
Engine fails to start	<ol style="list-style-type: none"> 1. PTO engaged. 2. Spark plug wire disconnected. 3. Fuel tank empty, or stale fuel. 4. Choke not activated. 5. Faulty spark plug. 6. Blown fuse(s). 7. Engine flooded. 8. Parking brake not engaged. 9. Throttle/choke control lever not in correct starting position. 10. Dead battery. 	<ol style="list-style-type: none"> 1. Place PTO in disengaged (PTO OFF) position. See page 12. 2. Connect wire to spark plug. See Engine Operator's Manual. 3. Fill tank with clean, fresh (less than 30 days old) gas. See page 9. 4. Place the throttle/choke control lever in CHOKE position. 5. Clean, adjust gap or replace plug. See Engine Operator's Manual. 6. Replace fuse(s). See page 17. 7. Crank engine with throttle/choke control lever in FAST position. See page 13. 8. Engage parking brake. See page 11. 9. Place throttle/choke control lever to FAST position. See page 13. 10. Clean, charge, jump start or replace battery. See page 16.
Engine runs erratic	<ol style="list-style-type: none"> 1. Unit running with CHOKE activated. 2. Spark plug wires loose. 3. Blocked fuel line or stale fuel. 4. Vent in gas cap plugged. 5. Water or dirt in fuel system. 6. Dirty air cleaner. 	<ol style="list-style-type: none"> 1. Move the throttle/choke control lever out of the CHOKE position. See page 13. 2. Connect and tighten spark plug wire. See Engine Operator's Manual. 3. Clean fuel line; fill tank with clean, fresh gasoline and replace fuel filter. See page 9. 4. Clear vent or replace cap if damaged. See page 9. 5. Drain fuel tank. Refill with clean, fresh gasoline. See page 9. 6. Replace air cleaner paper element or clean foam pre-cleaner. See Engine Operator's Manual.
Engine overheats	<ol style="list-style-type: none"> 1. Engine oil level low. 2. Air flow restricted. 	<ol style="list-style-type: none"> 1. Fill crankcase with proper quantity and viscosity of oil. See Engine Operator's Manual. 2. Clean grass clippings and debris from around the engine's cooling fins and blower housing.
Engine hesitates at high RPM	<ol style="list-style-type: none"> 1. Spark plug gap too close. 	<ol style="list-style-type: none"> 1. Remove spark plug and reset the gap. See Engine Operator's Manual.
Engine idles rough	<ol style="list-style-type: none"> 1. Spark plug fouled, faulty or gap too wide. 2. Dirty air cleaner. 	<ol style="list-style-type: none"> 1. Replace spark plug. Set plug gap. See Engine Operator's Manual. 2. Replace air cleaner element and/or clean pre-cleaner. See Engine Operator's Manual.
Excessive vibration	<ol style="list-style-type: none"> 1. Cutting blade loose or unbalanced. 2. Damaged or bent cutting blade. 	<ol style="list-style-type: none"> 1. Tighten blade and spindle. Balance blade. See page 18. 2. Replace blade. See page 18.
Mower will not mulch grass	<ol style="list-style-type: none"> 1. Engine speed too low. 2. Wet grass. 3. Excessively high grass. 4. Dull blade. 	<ol style="list-style-type: none"> 1. Place throttle/choke control lever in FAST (rabbit) position. See page 13. 2. Do not mulch when grass is wet. 3. Mow once at a high cutting height, then mow again at desired height or make a narrower cutting path. 4. Sharpen or replace blade. See page 18.
Uneven cut	<ol style="list-style-type: none"> 1. Deck not leveled properly. 2. Dull blade. 3. Uneven tire pressure. 	<ol style="list-style-type: none"> 1. Perform side-to-side deck adjustment. See page 17. 2. Sharpen or replace blade. See page 18. 3. Check tire pressure in all four tires. page 18.