



Outdoor Unit

18K: 2U18MS2VHB
 24K: 3U24MS2VHB
 36K: 4U36MS2VHB



Compact Cassette Type Indoor

9K: AB09SC2VH*
 12K: AB12SC2VH*
 18K: AB18SC2VH*



Wall Mount Type Indoor

7K: AW07LC2VH*
 9K: AW09LC2VH*
 12K: AW12LC2VH*
 18K: AW18LC2VH*



Slim Duct Type Indoor

7K: AD07SL2VH*
 9K: AD09SL2VH*
 12K: AD12SL2VH*
 18K: AD18SL2VH*

Table of Contents

Outdoor Unit Installation	2-13
Introduction - Overview	2-4
Step 1 - Preparation	5
Step 2 - Installation of the Outdoor Unit	6
Step 3 - Refrigerant Line Connections	6-8
Step 4 - Leak Test and Evacuation	8-9
Step 5 - Electrical Connections	10-11
Step 6 - Charging	12
Step 7 - System Test	12
Step 8 - Explaining Operation to the End User	12
Seacoast Application	13
Indoor Unit Installation - Cassette	14-19
Introduction - Overview	14-15
Step 1 - Preparation	16
Step 2 - Installation of the Cassette Unit	17-18
Step 3 - Electrical Connections	19
Step 4 - Louver Installation	19
Step 5 - Pull Vacuum on System	19
Indoor Unit Installation - Wall Mount	20-24
Introduction - Overview	20
Step 1 - Preparation	21
Step 2 - Installation of the Wall Mount Unit	22-23
Step 3 - Electrical Connections	24
Step 4 - Pull Vacuum on System	24
Indoor Unit Installation - Slim Duct	25-30
Introduction - Overview	25-26
Step 1 - Preparation	27
Step 2 - Installation of the Slim Duct Unit	28-29
Step 3 - Electrical Connections	30
Step 4 - Pull Vacuum System	30
Remote Controller	31-34

Outdoor Unit Installation

Introduction - Overview

Outdoor Unit Product Information

The FlexFit Multi-zone Heat Pump systems feature DC inverter technology to deliver high energy efficiency. The inverter technology operates variable speed compressors and fan motors. The outdoor is equipped with electronic expansion valves, which control refrigerant flow independently to each indoor unit that is installed. All of the outdoor units feature an internal oil separator to increase compressor life. These systems use R-410A refrigerant.

Some models feature self diagnostic boards that will check the integrity of field installed wiring prior to the system start up.

All outdoor units have built in diagnostic error detection circuits. If an error is detected, the system will take the necessary steps to either make adjustments or shut down to prevent damage from occurring. Some error codes will be displayed on the indoor unit display panel.

These systems can be connected to up to 4 individual indoor units. It is not necessary to use all of the available ports. The available combinations of indoor and outdoor unit capacities are listed in this manual. Available indoor units include high wall type, cassette type and Slim Duct/Concealed type.

Refrigerant line connections are flare connect.

The outdoor unit provides power to indoor units via terminal connections on the outdoor unit.

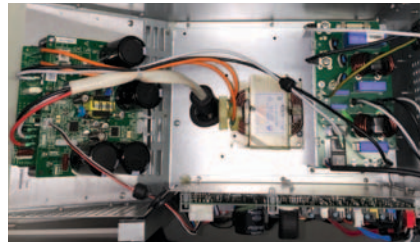

Control Boards



Self Diagnostic Board

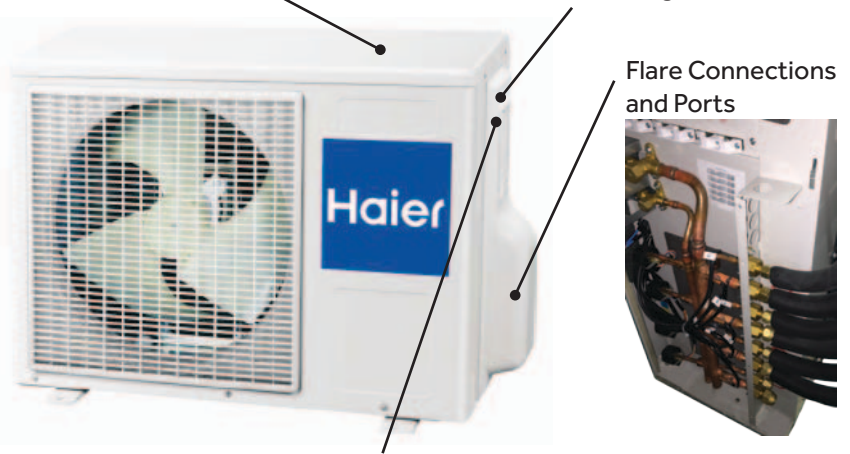

Flare Connections and Ports

Indoor Unit Power and Comm Wiring



Outdoor Unit Product Information

Temperature Control and the Inverter

The outdoor unit inverter will operate the compressor, outdoor fan motor and indoor fan motor at the proper speed to provide enough capacity to satisfy the heat load from all operating indoor units.

As the temperature in the zones gets closer to the setpoint requirement, the inverter will slow everything down. This is normal operation.

As temperature setpoint is reached, the inverter will run everything slowly to provide small amounts of capacity to keep the rooms comfortable. At times, the air coming out of the indoor units will be close to or at room temperature. This is normal.

This precise match of capacity and load is how ductless air conditioners achieve high efficiency ratings.

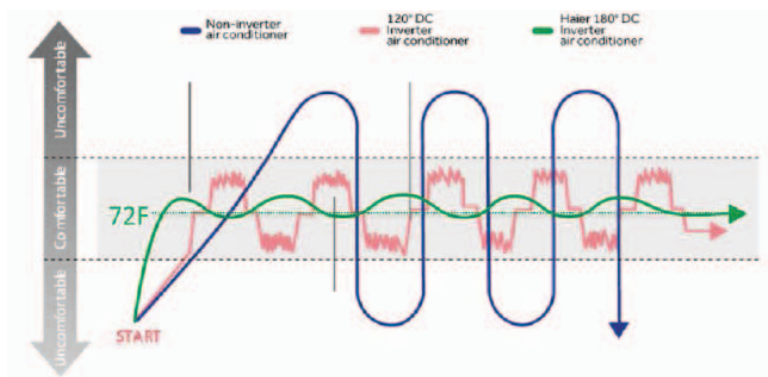

Matching up the outdoor unit to indoor units

The approved combinations of indoor unit capacity and outdoor unit model are shown at the right. The capacity ratings can be matched to any of the high wall, cassette, or Slim Duct/Concealed models.

The systems are not rated for use of only 1 indoor unit. Do not vary from the available combinations in these tables.

When ports are not used, always connect the refrigerant lines to circuits located at the outdoor units lowest possible connection. Use line reducing fittings to transition from the outdoor port size to the required port size of the indoor unit.

Operating Temperature Ranges

- Cool Mode: 14°F - 114°F
- Heat Mode: 5°F - 74°F

2U18MS2VHB	Combinations		Total Capacity (kBTU)
	Unit A	Unit B	
Two Zone	7	7	14
	7	9	16
	7	12	19
	9	9	18
	9	12	21
	12	12	24

3U24MS2VHB	Combinations			Total Capacity (kBTU)
	Unit A	Unit B	Unit C	
Two Zone	7	7	—	14
	7	9	—	16
	7	12	—	19
	7	18	—	25
	9	9	—	18
	9	12	—	21
	9	18	—	27
	12	12	—	24
Three Zone	7	7	7	21
	7	7	9	23
	7	7	12	26
	7	9	9	25
	9	9	9	27
	7	9	12	28
	7	9	12	28

4U36MS2VHB	Combinations				Total Capacity (kBTU)
	Unit A	Unit B	Unit C	Unit D	
Two Zone	9	18	—	—	27
	12	18	—	—	30
	18	18	—	—	36
Three Zone	7	7	18	—	32
	7	9	12	—	28
	7	9	18	—	34
	7	12	12	—	31
	7	12	18	—	37
	9	9	9	—	27
	9	9	12	—	30
	9	9	18	—	36
	9	12	12	—	33
	9	12	18	—	39
	12	12	12	—	36
	12	12	18	—	42
Four Zone	7	7	7	7	28
	7	7	7	9	30
	7	7	7	12	33
	7	7	7	18	39
	7	7	9	9	32
	7	7	9	12	35
	7	7	9	18	41
	7	7	12	12	38
	7	9	9	9	34
	7	9	9	12	37
	7	9	9	18	43
	7	9	12	12	40
	7	12	12	12	43
	9	9	9	9	36
	9	9	9	12	39
9	9	12	12	42	

Product Specifications

Model Number	Outdoor	2U18MS2VHB	3U24MS2VHB	4U36MS2VHB
Cooling Non-ducted	Rated Capacity Btu/hr	17,400	22,500	34,000
	Capacity Range Btu/hr	4,400-19,400	5,000-24,500	5,000-36,000
	Rated Power Input W	1,650	2,250	3,770
	SEER	16.0	18.0	18.0
	EER	10.5	10.0	9.0
Cooling Ducted	Rated Capacity Btu/hr	16,500	21,000	31,000
	Capacity Range Btu/hr	4,400-19,400	5,000-23,000	5,000-34,000
	Rated Power Input W	1,800	2,416	3,590
	SEER	15.5	16.0	16.0
	EER	8.5	8.5	8.5
Heating Non-ducted	Rated Heating Capacity 47°F Btu/hr	19,100	23,000	34,500
	Heating Capacity Range Btu/hr	6,100-22,100	6,100-25,500	6,100-36,500
	Rated Power Input W	1,570	1,700	2,650
	HSPF	9.0	10.0	10.0
	Rated Heating Capacity 17°F Btu/hr	13,000	15,000	22,000
	Max. Heating Capacity 17°F Btu/hr	14,000	18,000	26,000
Heating Ducted	Rated Heating Capacity 47°F Btu/hr	18,000	22,000	33,000
	Heating Capacity Range Btu/hr	6,100-22,100	6,100-25,000	6,100-35,000
	Rated Power Input W	1,700	2,100	3,000
	HSPF	8.2	8.5	9.0
	Rated Heating Capacity 17°F Btu/hr	10,000	14,000	21,000
	Max. Heating Capacity 17°F Btu/hr	12,000	17,000	25,000
Operating Range	Cooling °F(°C)	14~115(-10~46)	14~115(-10~46)	14~115(-10~46)
	Heating °F(°C)	-4~75(-20~24)	-4~75(-20~24)	-4~75(-20~24)
Power Supply	Voltage, Cycle, Phase V/Hz/-	208-230/60/1	208-230/60/1	208-230/60/1
Outdoor Unit	Compressor Type	DC Interfer Driven Rotary		
	Maximum Fuse Size A	25	25	30
	Minimum Circuit Amp A	15	18	23
	Outdoor Fan Speed RPM	300 ~ 900	300 ~ 900	300 ~ 900
	Outdoor Noise Level dB	53	54	56
	Dimension: Height in (mm)	27 1/16(688)	28 3/4(730)	33 1/16(840)
	Dimension: Width in (mm)	31 7/8(810)	33 7/8(860)	37 5/16(948)
	Dimension: Depth in (mm)	11 5/16(288)	12 1/8(308)	13 3/8(340)
Weight (Ship/Net)- lbs (kg)	102.5/95.9(46.5/43.5)	123.4/116.8(56/53)	191.8/167.5(87/76)	
Indoor Unit	Max Indoor units	2	3	4
Refrigerate Line	Connections	Flare	Flare	Flare
	Liquid O.D. in	1/4 1/4	1/4 1/4 1/4	1/4 1/4 1/4 1/4
	Suction O.D. in	3/8 3/8	3/8 3/8 3/8	3/8 3/8 3/8 1/2
	Factory Charge Oz	49.5	74.0	113.0
	Maximum Line Length Ft / m	100/30	200/60	230/70
	Maximum Height Ft / m	50/15	50/15	50/15
	Maximum Line Length for each individual indoor unit Ft / m	82/25	82/25	82/25

Step 1 - Preparation

Required Tools for Installation

- Drill
- Wire Snipper
- Hole Saw 2 3/4"
- Vacuum pump
- Soap-and-water solution or gas leakage detector
- Torque wrench
- 17mm, 22mm, 26mm
- Tubing cutter
- Flaring tool
- Razor knife
- Measuring tape
- Level
- Micron gauge
- Nitrogen
- Mini-Split AD-87 Adapter (1/4" to 5/16")
- A - Non-adhesive Tape
- B - Adhesive Tape
- C - Saddle (L.S.) with screws
- D - Electrical wiring
- E - Drain hose (Included)
- F - Insulation
- G - Piping hole cover (Included)

Procedure for Selecting the Location

- Choose a place solid enough to bear the weight and vibration of the unit and where the operation noise will not be amplified.
- Choose a location where the hot air discharged from the unit or the operation noise will not cause a nuisance to the neighbors of the user.
- There must be sufficient space for carrying the unit into and out of the site.
- There must be sufficient space for air passage and no obstructions around the air inlet and air outlet.
- The site must be free from the possibility of flammable gas leakage in a nearby place.
- Locate the unit to avoid noise and discharged hot air will not annoy the neighbors.
- Install units, power cords and inter-unit cables at least 10ft away from television and radio sets. This is to prevent interference to images and sounds. (Noise may be heard even if they are

- more than 10ft away depending on radio wave conditions.)
- Since drain flows out of the outdoor unit, do not place anything under the unit that must be kept away from moisture.

Note:

- 1) Cannot be installed hanging from ceiling or stacked.
- 2) If installing on a high place such as a roof, with a fence or guard rail around it.
- 3) If there is a potential for accumulated snow to block the air inlet or heat exchanger, install the unit on a higher base.
- 4) R-410A refrigerant is a safe, nontoxic and nonflammable refrigerant. However, if there is a concern about a dangerous level of refrigerant concentration in the case of refrigerant leakage, add extra ventilation.
- 5) Avoid installing the outdoor unit where corrosive gases, such as sulfur oxides, ammonia, and sulfurous gas, are produced. If unavoidable, consult with an installation specialist about using a corrosion-proof or anti-rust additive to protect the unit coils.

Outdoor Unit Clearances

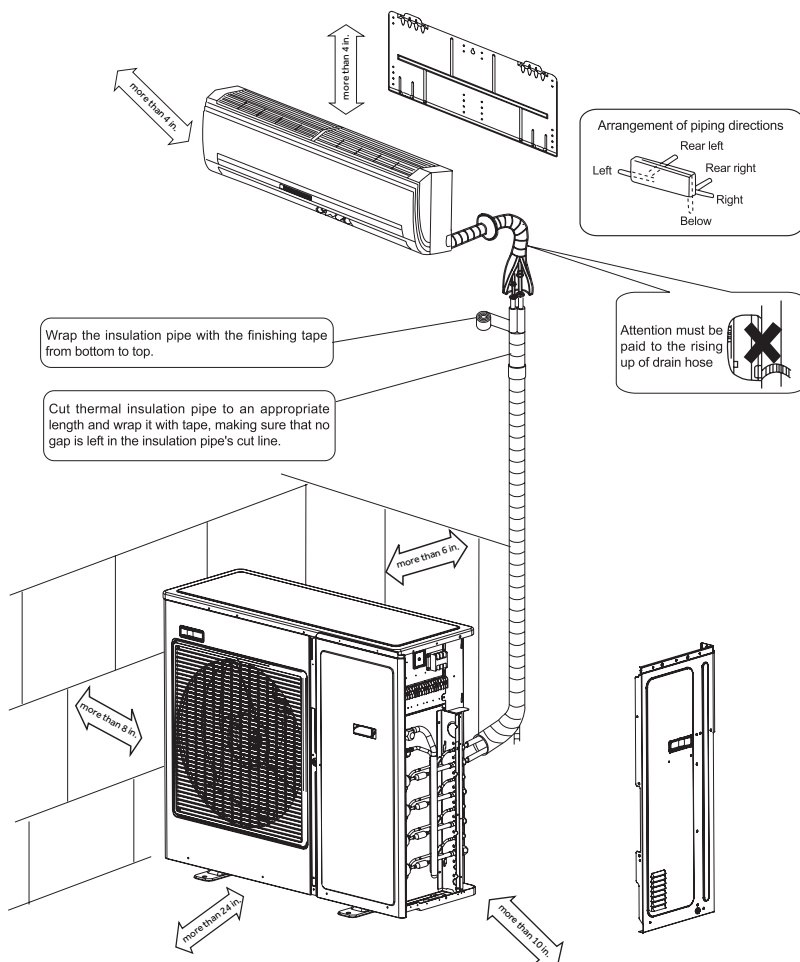

If there is the danger of the unit falling or overturning, fix the unit with foundation bolts, or with wire or other means. If the location does not have good drainage, place the unit on a level mounting base (or a plastic pedestal). Install the outdoor unit in a level position. Failure to do so may result in water leakage or accumulation.

Wall facing one side (in.)

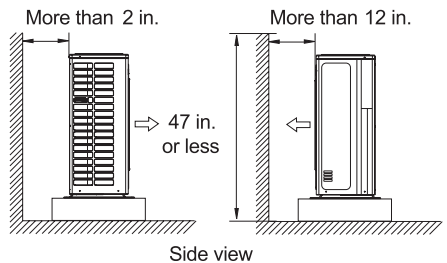

Wall facing two sides

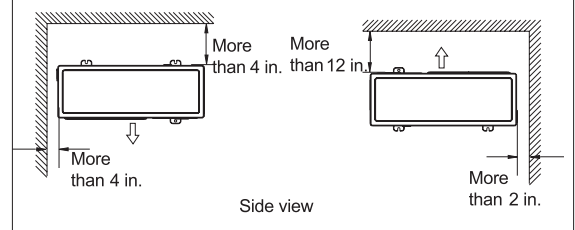

Wall facing three sides

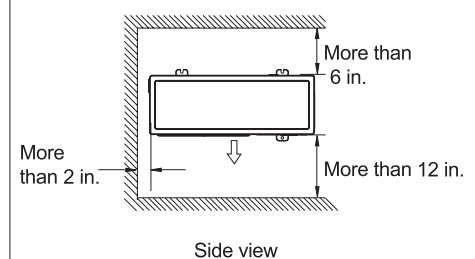

Step 2 - Installation of the Outdoor Unit

Set the Outdoor Unit

2.1 Step - 2.1

Set the unit on mount or pad. If located in snow area, use heat pump risers to elevate the outdoor unit.

Make sure the outdoor unit is installed level and is stable.

Attaching Drain Elbow to Outdoor Unit

2.2 Step - 2.2

If the unit is located in an area where freezing can occur, do not install the rubber drain fitting onto the bottom of the unit. If the area stays above freezing, insert the drain fitting per these instructions.

If attaching the supplied drain elbow to the outdoor unit, do so prior to attaching the refrigerant lines and wiring. Extension piping to attach to this fitting is field supplied.

Use drain plug for drainage.

If the drain port is covered by a mounting base or floor surface, place additional foot bases of at least 1 1/6 in. in height under the outdoor unit's feet.

In cold areas, do not use a drain hose with the outdoor unit. (Otherwise, drain water may freeze, impairing heating performance.)

Step 2.2

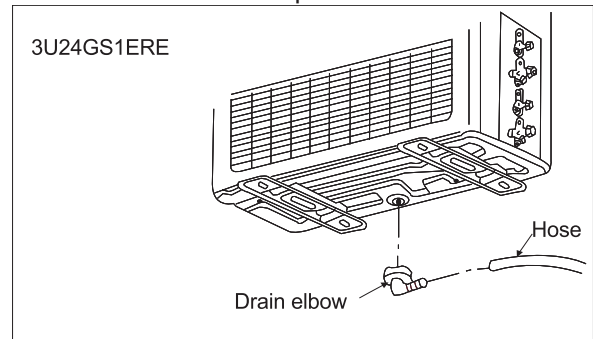

Step 3 - Refrigerant Line Connections

Piping Limits

The maximum lift allowed between the outdoor unit and COMBINED indoor units is 50 feet total of all installed units. For example, 3 units with 15 elevation each is 45 feet.

The maximum allowable piping length for ALL INSTALLED indoor units is a total of:

18K Outdoor Models: 100 Feet
24K Outdoor Models: 200 Feet
36K Outdoor Models: 230 Feet

The maximum refrigerant piping length allowable to a Cassette unit is 82 feet.

Pipe Size

Use the refrigerant line size that is indicated in the specification information for each indoor unit. Use stub adapters to adapt size to the outdoor unit if necessary.

Connection Priority

The line sets are connected to the indoor piping port connections labeled A through D. The connections are made with a flare fitting. Flare nut fittings are included with the unit.

Note: Start the connections at the lowest port. Always size the lines to the requirement of the indoor unit. Use a line size adapter if the required line size differs from the port size on the outdoor unit.

If any ports are not used, they remain capped. Unused ports should be near the top of the outdoor unit connection manifold. Remember, always start from bottom to top.

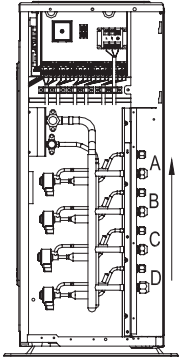
Connection cautions	
model	4U36HS1ERE
connection priority between indoor and stop valve higher from down to up	
when there is 1 indoor, the prior stop valve is	D
when there are 2 indoors, the prior stop valves are	D C
when there are 3 indoors, the prior stop valves are	D C B
when there are 4 indoors, the prior stop valves are	D C B A
Note: For better oil return and more reliable system, please execute as the above when connecting indoor unit.	

*MUST CONNECT (2) INDOOR UNITS

Step 3 - Refrigerant Line Connections

Piping Connection

3.1 Step - 3.1

Refrigerant piping connections for the mini-split system are made utilizing flare connections. Follow standard practices for creating pipe flares. When cutting and reaming the tubing, use caution to prevent dirt or debris from entering the tubing. Remember to place the nut on the pipe before creating the flare.

3.2 Step - 3.2

To join the lineset piping together, directly align the piping flare to the fitting on the other pipe, then slide the nut onto the fitting and tighten. Misalignment may result in a leaking connection.

3.3 Step - 3.3

Two wrenches are required to join the flare connections, one standard wrench, and one torque wrench. See Table 1 for the specific torque per piping diameter.

Step 3.1



Step 3.2

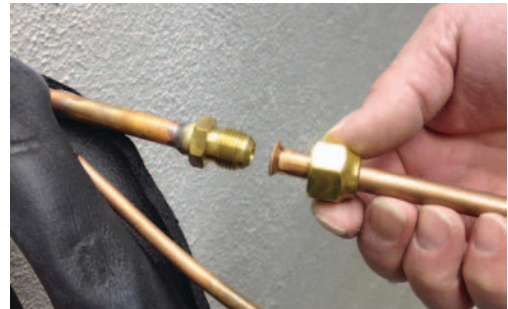

Step 3.3



Table 1

Forced fastening without careful centering may damage the threads and cause a leakage of gas.

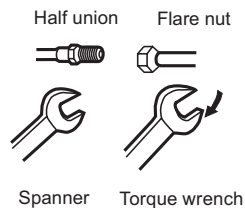

Pipe Diameter(ϕ)	Fastening torque
Liquid side 6.35mm(1/4")	18N.m/13.3Ft.lbs
Liquid/Gas side 9.52mm(3/8")	42 N.m/30.1Ft.lbs
Gas side 12.7mm(1/2")	55N.m/40.6Ft.lbs
Gas side 15.88mm(5/8")	60 N.m/44.3Ft.lbs

Step 4 - Leak Test and Evacuation

Leak Test

Hazard of Explosion! Never use an open flame to detect gas leaks. Explosive conditions may occur. Use a leak test solution or other approved methods for leak testing. Failure to follow recommended safe leak test procedures could result in death or serious injury or equipment or property damage.

Use only dry nitrogen with a pressure regulator for pressurizing unit. Do not use acetylene, oxygen or compressed air or mixtures containing them for pressure testing. Do not use mixtures of a hydrogen containing refrigerant and air above atmospheric pressure for pressure testing as they may become flammable and could result in an explosion. Refrigerant, when used as a trace gas should only be mixed with dry nitrogen for pressurizing units. Failure to follow these recommendations could result in death or serious injury or equipment or property damage.

4.1 Step - 4.1

Using a tank of nitrogen with attached regulator, charge the system with 150 PSIG of dry nitrogen. Use adapter AD-87 (field supplied) to connect to the valve. Check for leaks at the flare fittings using soap bubbles or other detection methods. If a leak is detected, repair and recheck. If no leaks are detected, proceed to evacuate the system.

Step 4.1



Step 4 - Leak Test and Evacuation

Note: This system has one set of service valves. When evacuating the system, the service valve ports will have access to all indoor units and refrigerant line sets. Evacuation at the service valve ports will evacuate the ENTIRE piping system including indoor units.

System Evacuation

4.2 Step - 4.2

Attach a manifold gauge, micron gauge, and vacuum pump to the suction line port using adapter AD-87 (field supplied). (Illustration 5)

Evacuate the system to 350 microns.

Close the vacuum pump valve and check the micron gauge. If the gauge rises above 500 microns in 60 seconds, evacuation is incomplete or there is a leak in the system. If the gauge does not rise above 500 microns in 60 seconds, evacuation is complete.

4.3 Step - 4.3

Remove the adapter and hose connection from the suction line port, and replace the cap.

4.4 Step - 4.4A & 4.4B

Remove the caps from the liquid line and suction line valves. Using the hex wrench, open each of the valves, then replace and tighten the caps.

4.5 Step - 4.5

Wrap the lineset, drain line, and wiring starting at the bottom of the bundle with an overlap type wrap, concluding at the piping hole. Use a sealant to seal the piping hole opening to prevent weather elements from entering the building.

Verify the condensate drain line has a constant pitch downward for proper water flow. There should be no kinks or rises in the tubing which may cause a trapping effect resulting in the failure of the condensate to exit the piping.

Step 4.2



Illustration 5

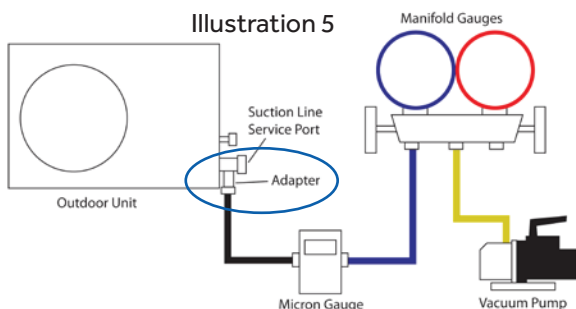

Step 4.3



Step 4.4A

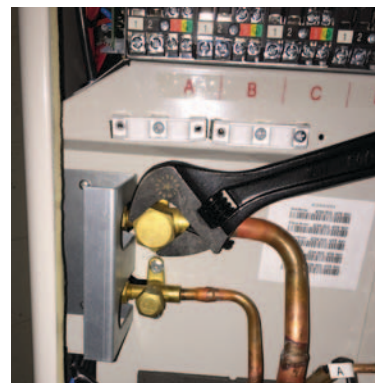

Step 4.4B

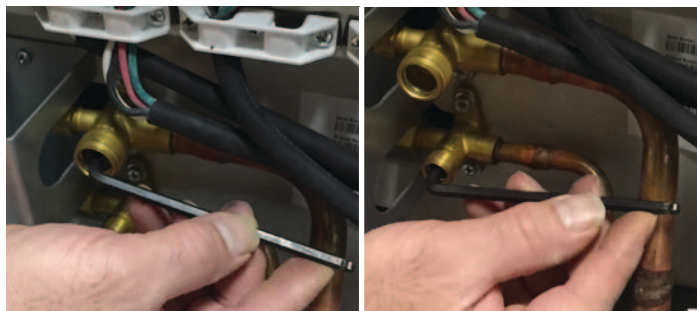

Step 4.5



Wiring Unit

5.1 Step - 5.1

Remove the cover plate of the outdoor unit to expose the terminal block connections.

5.2 Step - 5.2

Connect Line Voltage from Circuit Breaker/Disconnect to outdoor unit wire terminal

Always follow local and national codes when installing electrical wiring. The required fuse size can be found in the product specification section of this manual.

Connect wiring from indoor units

Use 14/4 AWG Stranded wire when connecting the outdoor unit to the indoor unit. **Connect the wiring to the correct terminals based upon the piping connections. For example, Circuit A wiring goes to the piping feeding Circuit A. Do not cross the wiring and piping.**

Step 5.1

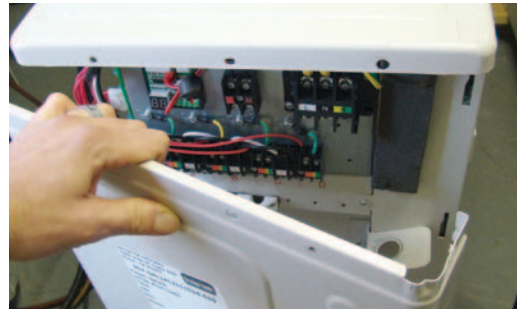

Step 5.2

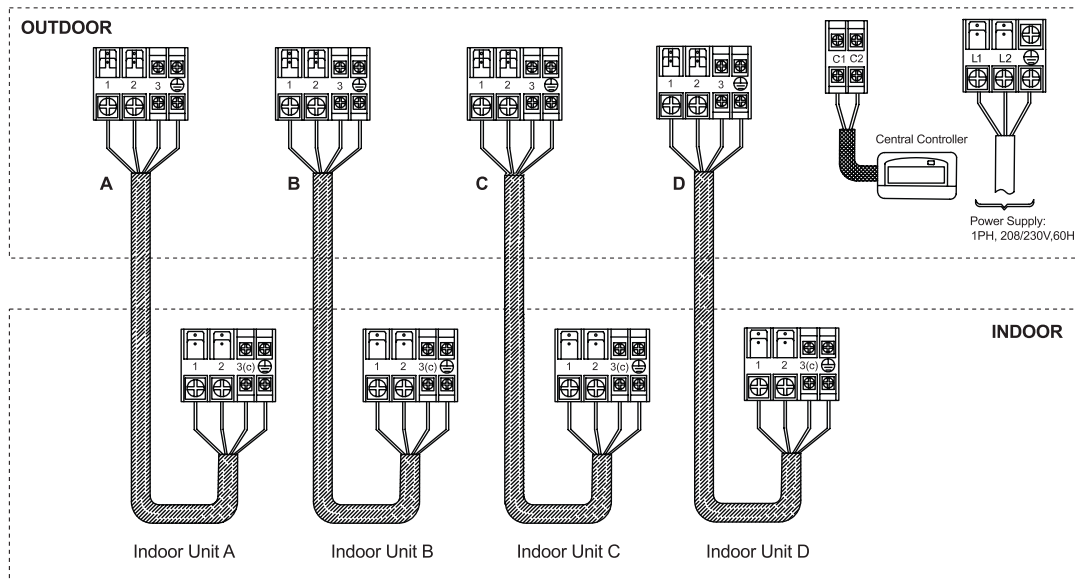
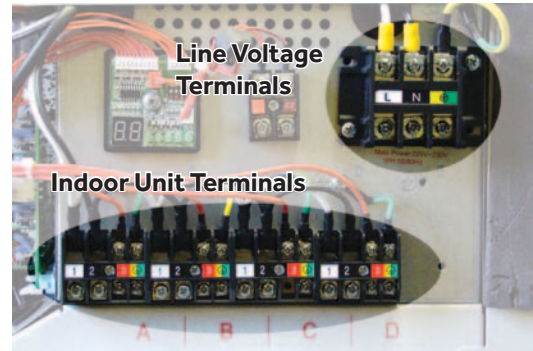

5.3 Step - 5.3

Replace the cover plate.

Wiring Error Check

This unit is capable of automatically checking for wiring errors between the indoor and outdoor units.

To enter the wiring error check test, place all 4 DIP switches of the test board to the ON position. (Illustration 6) Remove and reapply power to the unit, the system will enter the operation of "Wiring Error Check".

The numeric display will initialize and begin to alternate between the compressor working frequency (a number representing the Hz value) and "CH" (Checking).

As the check is being performed, all units that are properly connected will be indicated by the corresponding LED for that circuit being lit constantly. (LED 1 = piping circuit A, LED 2 = piping circuit B, ...)

After the check has completed, if all wiring is correct, the numeric display will indicate "0" and the single LEDs representing the individual circuits for the connected indoor units will be lit constantly.

If there are any miswired units, the numeric display will flash "EC" (error connection), and the corresponding LED for the miswired circuit will flash. Check and correct the wiring as needed.

Refer to the chart shown below. (Table 2)

When the test is complete, remove power to the system and return the 4 DIP switches to the OFF position. Reapply power to the the system. The test is complete.

If the self-check is not possible, check the indoor unit wiring and piping in the usual manner.

Illustration 6

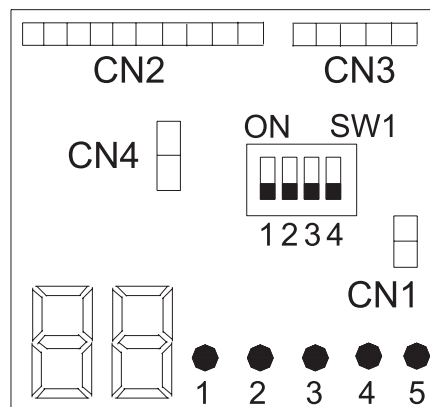

Table 2

LED	1	2	3	4	5	Message
Status	OFF					Unit not connected
	ALL Flashing					Automatic checking impossible, all units connect wrong
	ALL ON					All units connect correctly
	ON	FLASHING	FLASHING	ON	FLASHING	ON: unit connect correctly FLASHING: unit connect wrong, need to change the wiring manually between 2,3, and 5
	ON	FLASHING	FLASHING	ON	ON	ON: unit connect correctly FLASHING: unit connect wrong, need to change the wiring manually between 2,3
	Only one LED flashing					Abnormal

Step 6 - Charging

Charge the system using the weight method.

The unit comes with enough charge for 25 feet per circuit. For example, the 2 port unit will come with 50 feet of charge, the 3 port unit will come with 75 feet of charge, and the 4 port unit will come with 100 feet of charge. If the system must have additional charge added, **add .2 ounces of charge for every additional foot of refrigerant line that is above factory charge.** If the total of distance of the installed line sets is below factory charge, the factory charge is sufficient. Simply release the charge by opening the system service valves.



Step 7 - System Test

Check Items for Test Run

Put check mark in boxes

- No gas leak from linesets?
- Are the linesets insulated properly?
- Are the connecting wirings of indoor and outdoor firmly inserted to the terminal block?
- Is the wiring of indoor and outdoor firmly fixed?
- Is condensate draining correctly?
- Is the ground wire secure? Is the indoor unit secured?
- Is power source voltage correct according to local code?
- Is there any noise?
- Is the lamp normally lighting?
- Are cooling and heating performing normally?
- Is the operation of room temperature sensor normal?



Step 8 - Explaining Operation to the End User

- Using the OPERATING INSTRUCTIONS, explain to the user how to use the air conditioner (the remote controller, removing the air filters, placing or removing the remote controller from the remote controller holder, cleaning methods, precautions for operation, etc.)
- Recommend that the user read the OPERATING INSTRUCTIONS carefully.

Seacoast Application

- The outdoor unit should be installed at least ½ mile away from the salt water, including seacoasts and inland waterways. If the unit installed from ½ mile to 5 miles away from the salt water, including seacoasts and inland waterways, please follow the installation instruction below.
- Install the outdoor unit in a place (such as near buildings etc.) where it can be protected from sea breeze which can damage the outdoor unit.

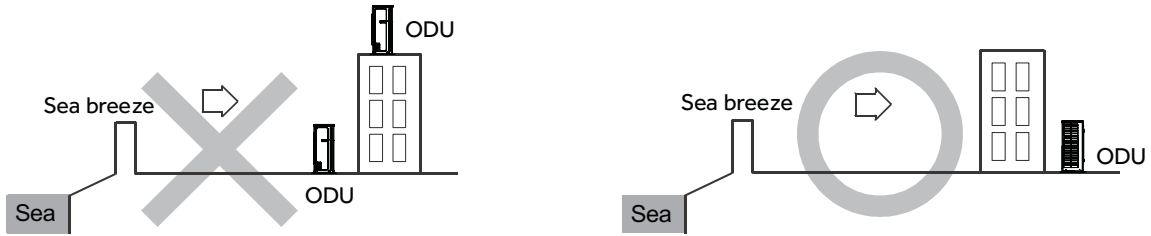

- If you cannot avoid installing the outdoor unit by the seashore, construct a protection wall around it to block the sea breeze.

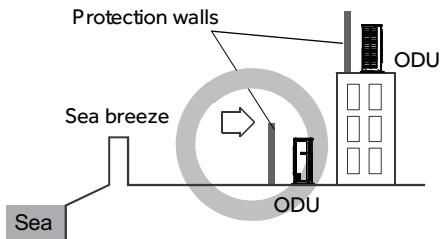

- A protection wall should be constructed with a solid material such as concrete to block the sea breeze and the height and the width of the wall should be 1.5 times larger than the size of the outdoor unit. Also, secure over 28 in (700mm) between the protection wall and the outdoor unit for exhausted air to ventilate.

- Install the outdoor unit in a place where water can drain smoothly.
- If you cannot find a place satisfying above conditions, please contact manufacturer. Make sure to clean the sea water and the dust on the outdoor unit heat exchanger.

Indoor Unit Installation - Cassette

Introduction - Overview

Cassette Product Information

The Cassette Indoor Air Handler ships consists of a cassette assembly and operational louver. The Cassette Indoor Unit is operated via a factory supplied remote control. Wired controller is optional.

The Cassette unit will install between standard dropped ceiling grids. It is mounted using threaded rods that fit into brackets that are located at all four corners of the cassette assembly.

The Cassette unit receives 230 volt line voltage from a connection at the outdoor condensing unit. There is no requirement for independent line voltage connections.

The cassette unit has a built in condensate pump and associated float switch that manages the operation of the condensate pump. A flexible hose is included with the Cassette unit. This hose connects the cassette condensate drain outlet to the buildings condensate drain system.

The motorized louver is controlled via the remote control. The louver has indicator lights that communicate function and diagnostic information to the user and service technician.

Optional fresh air can be piped into the cassette assembly. The knockout is located on the side of the cassette assembly. If fresh air is desired, be certain to filter the air prior to it entering the cassette. A 4" galvanized pipe should be used to pipe in the fresh air.

Included with the cassette unit is factory provided insulating tape. This tape should be placed over the refrigerant piping connections at the indoor unit to prevent sweating.

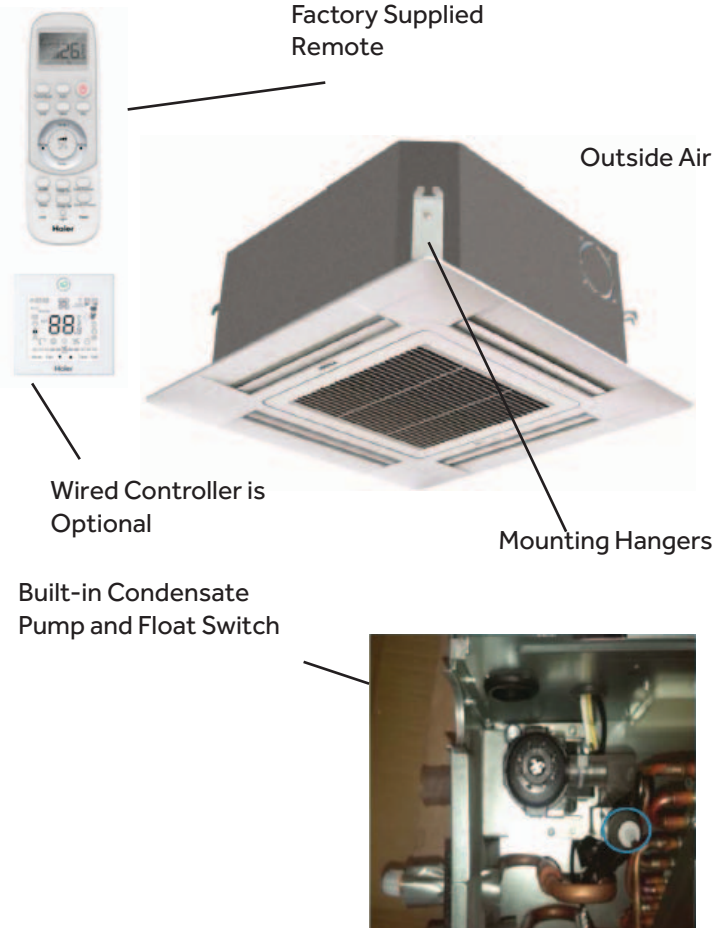

Cassette Indoor Unit Specifications

Indoor	AB09SC2VHA	AB12SC2VHA	AB18SC2VHA
Rated Cooling Capacity Btu/hr	9,000	12,000	18,000
Rated Heating Capacity Btu/hr	10,000	13,000	19,000
Voltage, Cycle, Phase V/Hz/-	208-230/60/1	208-230/60/1	208-230/60/1
Fan Speed Stages	5+Auto	5+Auto	5+Auto
Airflow (Turbo/High/Med/Low/ Quiet) CFM	410/365/305/265/205	410/365/305/265/205	470/410/365/295/252
Motor Speed (Turbo/High/Med/Low/ Quiet) RPM	750/690/620/560/500	750/690/620/560/500	830/750/690/610/550
Indoor Sound Level dB (Turbo/High/ Med/Low/Quiet)	42/40/36/32/25	42/40/36/32/25	45/42/40/36/32
Grill Model	PB-700IB	PB-700IB	PB-700IB
Chassis Dimension: Height in (mm)	10 1/4 (260)	10 1/4 (260)	10 1/4 (260)
Chassis Dimension: Width in (mm)	22 7/16(570)	22 7/16(570)	22 7/16(570)
Chassis Dimension: Depth in (mm)	22 7/16(570)	22 7/16(570)	22 7/16(570)
Grill Dimension: Height in (mm)	2 3/8 (60)	2 3/8 (60)	2 3/8 (60)
Grill Dimension: Width in (mm)	27 9/16 (700)	27 9/16 (700)	27 9/16 (700)
Grill Dimension: Depth in (mm)	27 9/16 (700)	27 9/16 (700)	27 9/16 (700)
Weight (Ship/Net)- lbs (kg)	46.3/37.5 (21/17)	48.5/40.8 (22/18.5)	48.5/40.8 (22/18.5)
Connections	Flare	Flare	Flare
Liquid O.D. in	1/4	1/4	1/4
Suction O.D. in	3/8	3/8	1/2
Drainpipe Size O.D. in	1 1/4	1 1/4	1 1/4
Internal Condensate Pump	Standard	Standard	Standard
Max. Drain-Lift height in(mm)	47 3/16(1,200)	47 3/16(1,200)	47 3/16(1,200)

Fresh Air Intake Option

The cassette has a marked area to cut out if outside air is desired. The piping connection should be made with a 4 inch diameter pipe. Outside air should be pre-filtered prior to entry into the cassette.



Condensate Handling

The Cassette unit has a built in condensate pump and water level safety switch. There is no option for gravity drain. The condensate pump is rated to lift water up to 24" from the point of discharge on the cassette assembly.



The cassette unit comes with a grey connection hose with clamp. This hose is connected to the cassette assembly discharge hose port. The other end of the hose is sized to accept 3/4 " PVC piping.



Recommended condensate piping configurations are shown here:

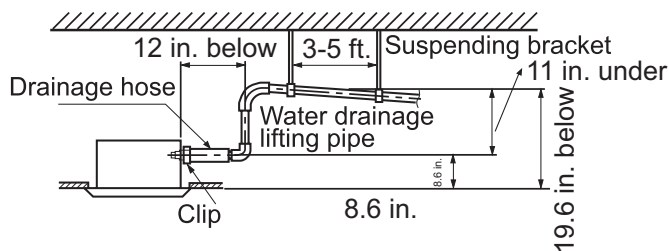

Electrical Power

Follow all local codes and regulations when installing electrical wiring.

Route required electrical power to area where cassette is to be located. Maintain at least a 10 foot separation between TV and Radio wiring and the power to the indoor unit.

14 Gauge AWG stranded wire should be used to make the electrical connection between indoor and outdoor units. This wiring will serve to power the indoor unit and establish a communication link between indoor and outdoor units.

The wiring is connected at the indoor unit electrical terminal blocks screws 1, 2, 3 and ground. There should be no splices in the wires connected to terminals 1 or 3 as these serve as communication signal wires and electrical power connections. If a safety switch needs to be in place to shut off power to the indoor unit, break wire 2 only.



Air Delivery Clearances

Make certain to maintain proper clearances around the cassette as specified in the installation instructions. Standard clearances for cassette air handlers require 5 feet of clearance in each direction. There should be 8 feet of clearance from the face of the cassette louver to the floor. Inadequate clearances can cause system freezing and temperature control problems.

Service and Maintenance Clearances

Make sure there are adequate clearances for future maintenance and service. Allow enough room to access the condensate pump assembly and the electrical control box.

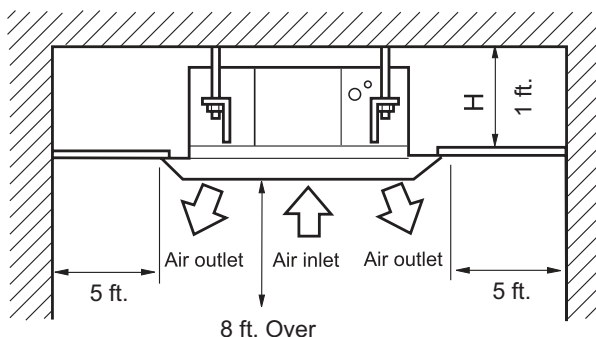

Step 1 - Preparation

Required Tools for Installation

- Drill
- Wire Snipper
- Hole Saw 2 3/4"
- Vacuum pump
- Soap-and-water solution or gas leakage detector
- Torque wrench
- 17mm, 22mm, 26mm
- Tubing cutter
- Flaring tool
- Razor knife
- Measuring tape
- Level
- Micron gauge
- Nitrogen
- Mini-Split AD-87 Adapter (1/4" to 5/16")
- A - Non-adhesive Tape
- B - Adhesive Tape
- C - Saddle (L.S.) with screws
- D - Electrical wiring
- E - Drain hose (Included)
- F - Insulation
- G - Piping hole cover (Included)

Procedure for Selecting the Location

- Place above the ceiling where you have enough space to position the unit.
- Place where the drainage pipe can be properly positioned.
- Place where the inlet and outlet air of the indoor unit will not be blocked.
- Do not install the unit in a place with heavy oil or moisture (e.g. - kitchens and workshops)
- Do not install in a location with destructive gas (such as sulfuric acid gas) or pungent gas (thinner and gasoline) are used or stored.
- Choose a place solid enough to bear the weight and vibration of the unit and where the operation noise will not be amplified.
- Install where there are no expensive items like a television or piano below the indoor unit.
- Leave enough space for maintenance.
- Install at least 3 ft. away from televisions and radios to avoid interference.

Note:

- 1) R-410A refrigerant is a safe, nontoxic and nonflammable refrigerant. However, if there is a concern about a dangerous level of refrigerant concentration in the case of refrigerant leakage, add extra ventilation.

Threaded Rod Mounting Information

The Cassette unit should be mounted to the building structure using threaded rods. The threaded rods should have washers and nuts to allow the height and level of the cassette to be adjusted.

The threaded rods and attachment brackets are field supplied items. The materials required for mounting to the brackets on the cassette assembly include:

- 4- 3/8" Threaded Rods
- 4- Mounting Brackets
- 8- Washers
- 8- Nuts (Double nut the assembly as shown)

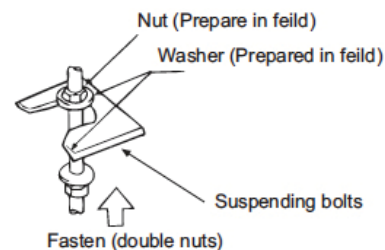
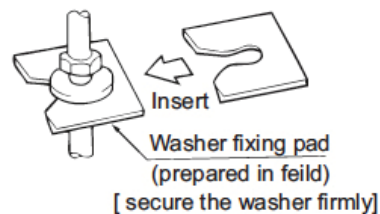
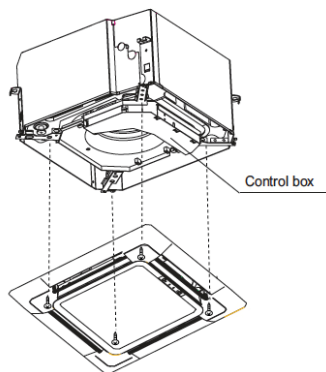

Step By Step Guide To Cassette Installation

2.1 Step 2.1

Use cardboard template to locate center point of cassette for mounting. Use a plumb bob and string to position cassette by referencing center hole of template. Mark the mounting positions of the threaded rods using the guides on the cardboard template.

2.2 Step 2.2

Install threaded rods to structure using appropriate fasteners.

2.3 Step 2.3

Lift the cassette and position the threaded rods into the 4 mounting clips on each corner of the cassette unit.

2.4 Step 2.4

Using a level, adjust the nuts on the threaded rods to obtain a level reading across the bottom of the cassette unit.

2.5 Step 2.5A & 2.5B

Prior to routing the refrigerant lines to the unit, install the supplied flare nuts onto the refrigerant lines. Using a flaring tool, flare the refrigerant lines. Remove the caps attached to the ends of the refrigerant line connections at the cassette. Holding gas should leak out.

Using a torque wrench, torque the fittings to the proper specifications. (See Outdoor Unit Section for flare torque settings.)

2.6 Step 2.6

Connect the grey flexible drain hose supplied with the cassette unit to the condensate pump discharge pipe of the cassette. Tighten the clamp securely. Using 3/4" PVC, connect the flexible hose to the building's condensate drain system.

2.7 Step 2.7

Remove the electrical box cover. Remove the rubber grommet and insert a 1/2 inch electrical connector and reducing washer. Route electrical wiring into cassette unit. Connect to wire terminas as indicated in schematic drawing. (USE 14 AWG Stranded wire only.)

2.8 Step 2.8A & 2.8B ,C, D

Connect Louver assembly to cassette assembly. Connect wires from louver to the harness on the cassette assembly. There are two wire connections. (See photo for connections.) Secure louver with four screws.

Reinstall electrical box cover.
Install return air grille into louver assembly.

Installation is now complete.

Step 2.1



Step 2.2



Step 2.3



Step 2.4



Step 2 - Installation of the Cassette Unit

Step 2.5A

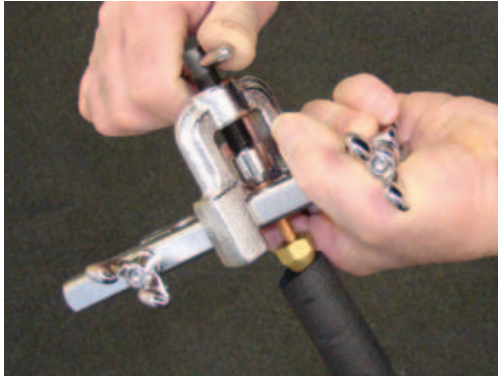

Step 2.5B

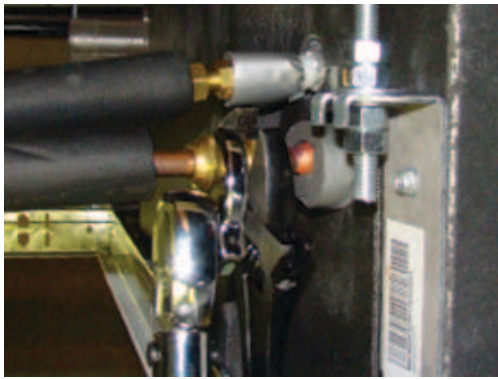

Step 2.6



Step 2.7



Step 2.8A



Step 2.8B



Step 2.8C



Step 2.8D



Step 3 - Electrical Connections

Electrical Connections Indoor and Outdoor Units

14 AWG Stranded Wire Only. (Central Controller Not Used)
Maintain 10 feet of separation between TV and any Radio wiring.

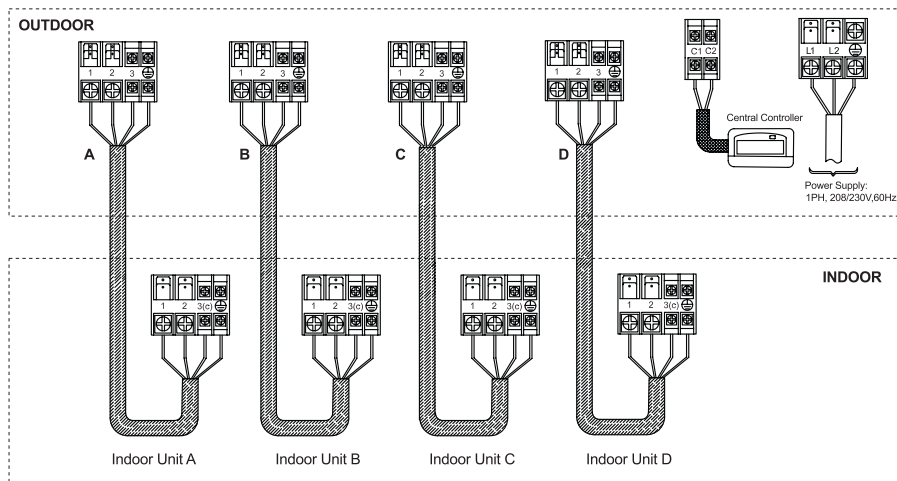

Step 4 - Louver Installation

To mount the louver cover onto the cassette assembly. Install 2 screws at the keyhole slot positions shown in the first photo. Place louver onto the 2 screws and press louver onto cassette housing. Swing hang clip into position. (White circle.) Install remaining 2 screws and tighten the 4 screws. Connect electrical plugs to socket shown below. Install the electrical cover box and then snap the return air grille into position.

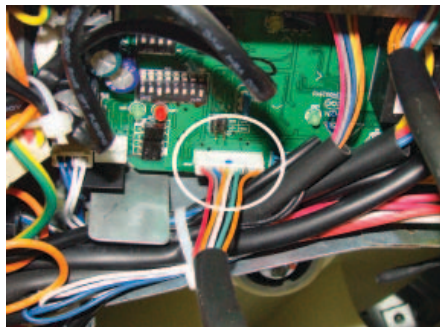

Step 5 - Pull Vacuum on System

See Step 4.2 of the outdoor unit installation section for how to pull a vacuum.

Indoor Cassette Unit Installation Complete

Indoor Unit Installation - Wall Mount

Introduction - Overview

Wall Mount Indoor Unit Specifications

Indoor	AW07LC2VHA	AW09LC2VHA	AW12LC2VHA	AW18LC2VHA
Rated Cooling Capacity Btu/hr	7,000	9,000	12,000	18,000
Rated Heating Capacity Btu/hr	8,000	10,000	13,000	19,000
Voltage, Cycle, Phase V/Hz/-	208-230/60/1	208-230/60/1	208-230/60/1	208-230/60/1
Fan Speed Stages	5+Auto	5+Auto	5+Auto	5+Auto
Airflow (Turbo/High/Med/Low/ Quiet) CFM	410/350/295/235/205	410/350/295/235/205	440/380/320/265/215	636/530/483/430/383
Motor Speed (Turbo/High/Med/ Low/Quiet) RPM	1050/950/800/650/600	1050/950/800/650/600	1100/1000/850/700/620	1100/950/850/750/600
Indoor Sound Level dB (Turbo/ High/Med/Low/Quiet)	43/38/33/26/22	43/38/33/26/22	44/39/34/27/23	48/45/40/35/30
Dimension: Height in (mm)	11 (280)	11 (280)	11 (280)	12 3/4 (332)
Dimension: Width in (mm)	33 5/8 (855)	33 5/8 (855)	33 5/8 (855)	39 1/4 (997)
Dimension: Depth in (mm)	8 1/16 (204)	8 1/16 (204)	8 1/16 (204)	9 1/4 (235)
Weight (Ship/Net)- lbs (kg)	26.8/22(12.2/10)	26.8/22(12.2/10)	26.8/22(12.2/10)	35.3/28.6 (16/13)
Connections	Flare	Flare	Flare	Flare
Liquid O.D. in	1/4	1/4	1/4	1/4
Suction O.D. in	3/8	3/8	3/8	1/2
Drainpipe Size O.D. in	5/8	5/8	5/8	5/8

Wall Mount Product Information

The Wall Mount Indoor Air Handler consists of a single compact unit, operated via a factory supplied remote control.

A display indicator located on the front panel of the unit provides temperature and operating modes of the system. It can also display error code conditions of the system.

The wall mount unit receives 230 volt line voltage from a terminal connection at the outdoor condensing unit. There is no requirement for independent line voltage connections.

Piping to the unit may be routed from one of several directions. (Left, left back, left down, right, right back and right down.)

A motorized louver at the front of the unit is controlled via the remote control. The louver may be set to either oscillate or remain in a stationary position.

Manual vanes located behind the louver may be set to help the direction of air flow.

Carbon and Catechin filters clip in to the filter screens to help filter the air.

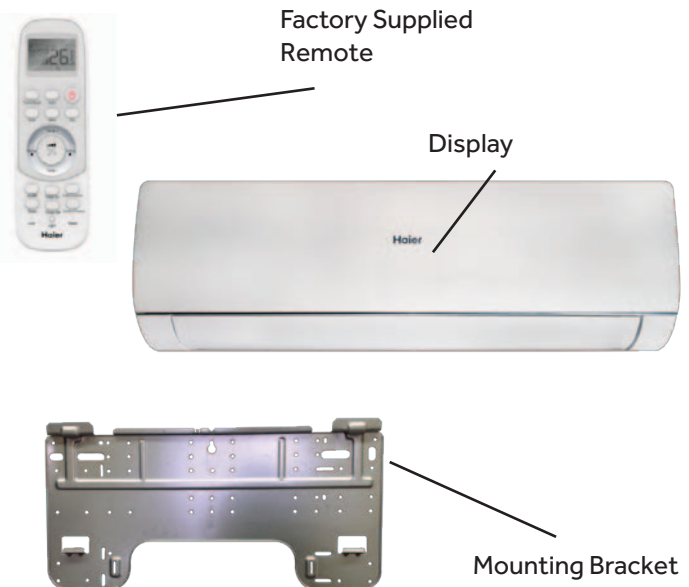

Step 1 - Preparation

Required Tools for Installation

- Drill
- Wire Snipper
- Hole Saw 2 3/4"
- Vacuum pump
- Soap-and-water solution or gas leakage detector
- Torque wrench
- 17mm, 22mm, 26mm
- Tubing cutter
- Flaring tool
- Razor knife
- Measuring tape
- Level
- Micron gauge
- Nitrogen
- Mini-Split AD-87 Adapter (1/4" to 5/16")
- A - Non-adhesive Tape
- B - Adhesive Tape
- C - Saddle (L.S.) with screws
- D - Electrical wiring
- E - Drain hose (Included)
- F - Insulation
- G - Piping hole cover (Included)

Procedure for Selecting the Location

- Choose a place solid enough to bear the weight of the unit.
- Avoid choosing a site with steam or heat
- When mounting the unit always maintain proper clearances
- Position so that the condensate can easily drain.
- An area where the piping can be connected with the outdoor unit.
- Where airflow can blow evenly throughout the room.
- Place a minimum distance of 3 ft. from televisions, radios, wireless apparatuses, and fluorescent lamps.
- When mounting the remote controller on a wall, position it where the indoor unit can receive the remotes infrared signals when fluorescent lamps in the room are in use.
- There must be sufficient space for air passage and no obstructions around the air inlet and air outlet.
- The site must be free from the possibility of flammable gas leakage in a nearby place.

Note:

1) R-410A refrigerant is a safe, nontoxic and nonflammable refrigerant. However, if there is a concern about a dangerous level of refrigerant concentration in the case of refrigerant leakage, add extra ventilation.

Clearances of Indoor and Outdoor Units

This picture is for reference only. Your product may look different. Read this manual before installation. Explain the operation of the unit to the user according to this manual.

The models adopt HFC free refrigerant R410A

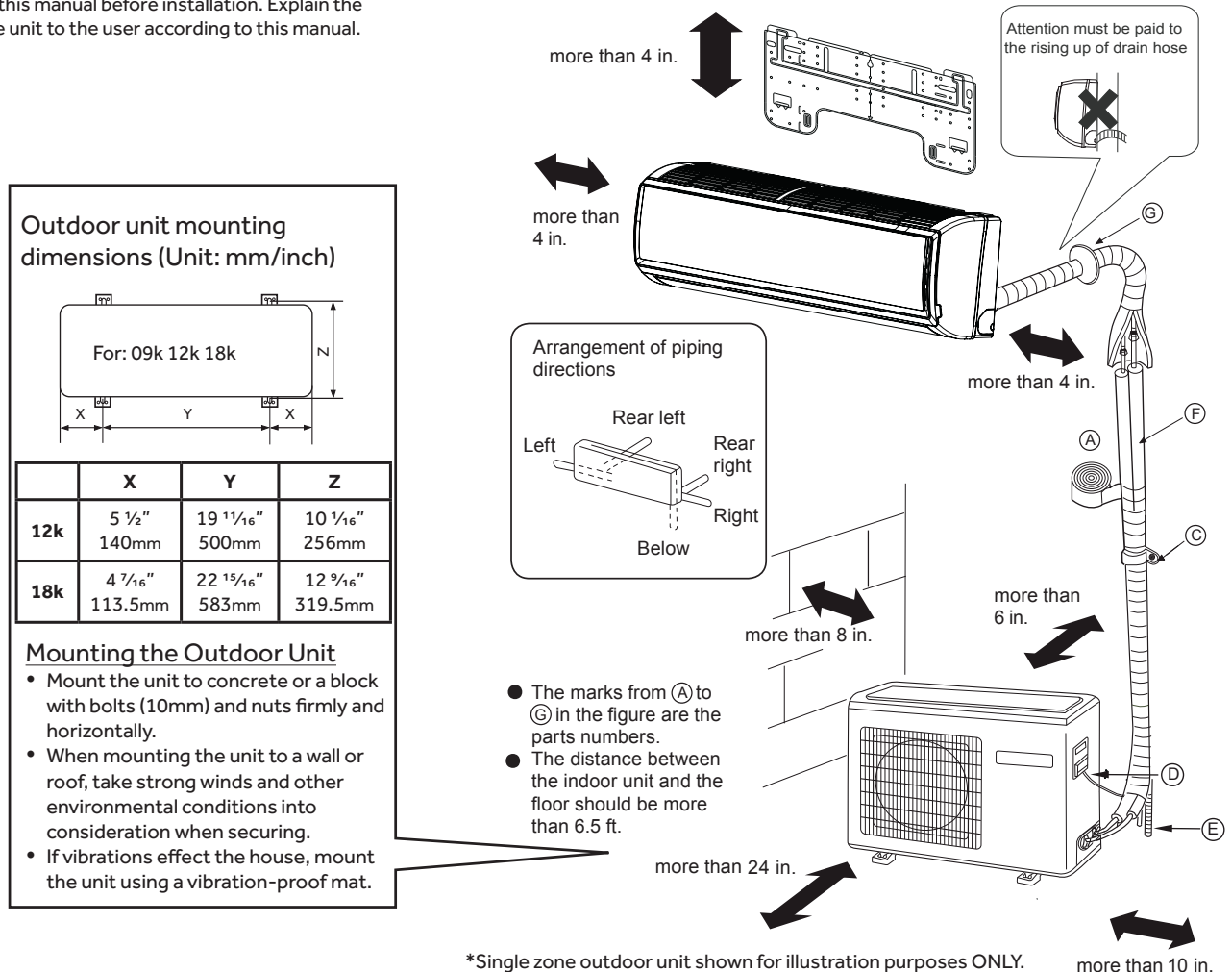

Attaching the Mounting Plate to the Wall

2.1 Step 2.1

Using a stud sensor, locate and mark the stud positions in the wall where the indoor unit is to be mounted.

2.2 Step 2.2

Place the mounting plate on the wall in the desired location taking into account the minimum clearances necessary for proper operation.

Using a level, verify the mounting plate is horizontal and mark the screw locations.

2.3 Step 2.3

Screw the mounting plate to the wall.

The piping for the indoor unit may be routed to the unit from one of several directions. Left, Left Rear, Right, Right Rear, or Below (Illustration 1).

2.4 Step 2.4

Knockouts are provided on the case for Left, Right, and Right Below.

Drilling the hole through the wall for left rear or right rear installation

2.5 Step 2.5A & 2.5B

Measure and mark the location where the piping hole is to be drilled.

Step 2.3



Illustration 1

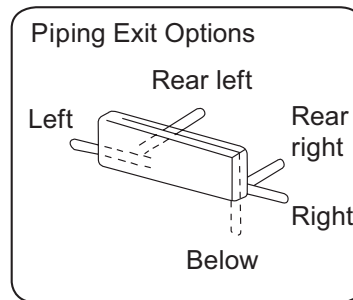

Step 2.4



Step 2.5A

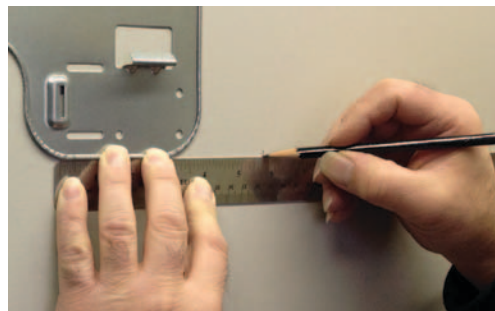

Step 2.1



Step 2.2



Step 2.5B



Step 2 - Installation of the Wall Mount Unit

2.6 Step 2.6

Drill the piping hole using a hole saw of the correct diameter. Angle the drill with a downward pitch to the outside wall so that the outside hole will be $\frac{1}{4}$ " lower than the inside hole, giving the hole the proper angle for condensate drainage.

2.7 Step 2.7

Install the piping hole cover flange at the hole opening on the inside wall.

NOTE: The cover flange may require modification to fit properly behind the wall unit housing.

2.8 Step 2.8A & 2.8B

Bundle the refrigerant piping, drain piping and wiring with tape and pass the bundle through the piping hole.

NOTE: When bundling the power cable, leave sufficient length available in the indoor unit to make the connections to the terminal block.

Mounting the Indoor Unit Onto the Wall Plate

2.9 Step 2.9

With the top of the indoor unit closer to the wall, hang the indoor unit on the upper hooks of the mounting plate. Slide the unit slightly side to side to verify proper placement of the indoor unit on the mounting plate. Rotate the lower portion of the indoor unit to the mounting plate, and lower the unit onto the lower hooks of the mounting plate. (Illustration 2) Verify the unit is secure.

2.10 Step - 2.10

Slightly raise the entire unit vertically, pull the lower portion of the unit off the lower hooks of the mounting plate and away from the wall, then lift the upper portion of the unit off the upper hooks of the wall plate.

Step 2.8A



Step 2.8B



Step 2.9



Illustration 2

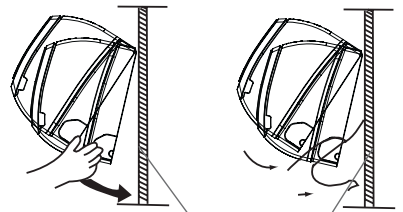

mounting plate

Step 2.10

Step 2.6



Step 2.7



Step 3 - Electrical Connections

3.1 Step - 3.1A & 3.1B

To make the electrical connections for the indoor unit, two cover plates must be removed. Raise the front cover to access the screws to remove these covers.

3.2 Step - 3.2 & 3.2A & 3.2B

Access the four conductor cable through the cover plate opening and make the wiring connections noting the wire color used on each terminal. The color of each wire must match the same positions on the terminal block of the outdoor unit. (Illustration 3)

Failure to wire the system correctly may lead to improper operation or component damage.

3.3 Step - 3.3A & 3.3B

After the terminal block wiring is completed, replace both cover plates.

Illustration 3

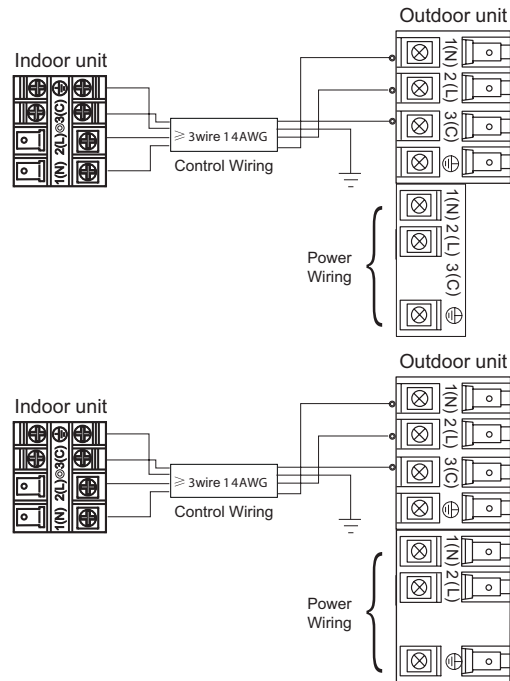

Step 3.1A



Step 3.1B



Step 3.2

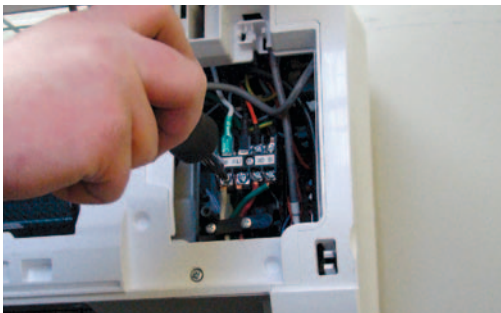

Step 3.3A



Step 3.3B



Step 4 - Pull Vacuum on System

See Step 4.2 of the outdoor unit installation section for how to pull a vacuum.

Indoor Wall Mount Unit Installation Complete

Indoor Unit Installation - Slim Duct

Introduction - Overview

Slim Duct Product Information

The Slim Duct Indoor Air Handler ships consisting of a single assembly. The Slim Duct indoor unit is operated via a factory supplied wired remote control.

The Slim Duct unit will install above the ceiling or in a soffit area. It is mounted using threaded rods that fit into brackets that are located at all four corners of the Slim Duct assembly.

The Slim Duct unit receives 230 volt line voltage from a connection at the outdoor condensing unit. There is no requirement for independent line voltage connections.

The Slim Duct unit has a built-in condensate pump and associated float switch that manages the operation of the condensate pump. A flexible hose is included with the Slim Duct unit. This hose connects the Slim Duct condensate drain outlet to the building's condensate drain system.

Included with the Slim Duct unit is factory provided insulating tape. This tape should be placed over the refrigerant piping connections at the indoor unit to prevent sweating.

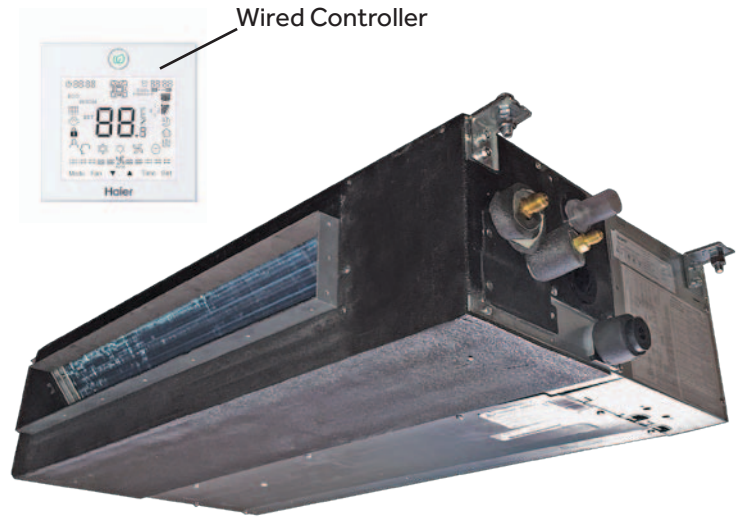

Built-in Condensate Pump and Float Switch

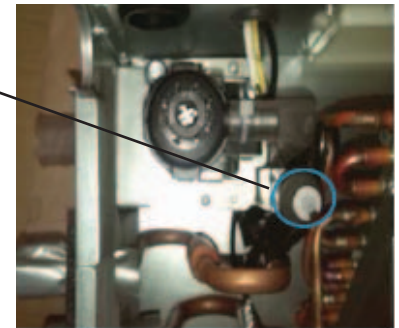

Slim Duct Indoor Unit Specifications

Indoor	AD07SL2VHA	AD09SL2VHA	AD12SL2VHA	AD18SL2VHA
Rated Cooling Capacity Btu/hr	7,000	9,000	12,000	18,000
Rated Heating Capacity Btu/hr	8,000	10,000	13,000	19,000
Voltage, Cycle, Phase V/Hz/-	208-230/60/1	208-230/60/1	208-230/60/1	208-230/60/1
Fan Speed Stages	5+Auto	5+Auto	5+Auto	5+Auto
Airflow (Turbo/High/Med/Low/ Quiet) CFM	353/312/270/230/188	353/312/270/230/188	400/353/282/247/218	540/500/447/365/306
Motor Speed (Turbo/High/Med/Low/ Quiet) RPM	950/850/750/650/550	950/850/750/650/550	1050/950/800/700/600	1050/950/850/750/650
Max. External Static Pressure in.W.G (Pa)	0.16 (40)	0.16 (40)	0.16 (40)	0.16 (40)
Indoor Sound Level dB (Turbo/High/ Med/Low/Quiet)	35/33/29/26/21	35/33/29/26/22	38/35/29/26/23	31/29/23/29/25
Dimension: Height in (mm)	7 5/16 (185)	7 5/16 (185)	7 5/16 (185)	7 5/16 (185)
Dimension: Width in (mm)	33 7/16 (850)	33 7/16 (850)	33 7/16 (850)	46 1/16 (1170)
Dimension: Depth in (mm)	16 9/16 (420)	16 9/16 (420)	16 9/16 (420)	16 9/16 (420)
Weight (Ship/Net)- lbs (kg)	47.2/36.8 (21.4/16.7)	47.2/36.8 (21.4/16.7)	47.2/36.8 (21.4/16.7)	61.8/48.5(28/22)
Connections	Flare	Flare	Flare	Flare
Liquid O.D. in	1/4	1/4	1/4	1/4
Suction O.D. in	3/8	3/8	3/8	1/2
Drainpipe Size O.D. in	1 1/4	1 1/4	1 1/4	1 1/4
Internal Condensate Pump	Standard	Standard	Standard	Standard
Max. Drain-Lift height in(mm)	27 9/16 (700)	27 9/16 (700)	27 9/16 (700)	27 9/16 (700)

Condensate Handling

The Slim Duct unit has a built-in condensate pump and water level safety switch. There are also two optional ports for gravity drainage. The condensate pump is rated to lift water up to 24" from the point of discharge on the Slim Duct unit.

The Slim Duct unit comes with a grey connection hose with clamp. This hose is connected to the Slim Duct unit condensate discharge hose port. The other end of the hose is sized to accept 3/4 inch PVC piping.

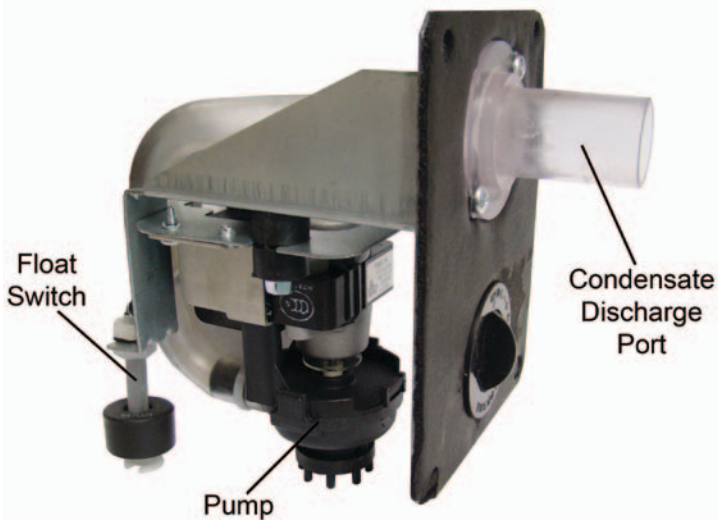

Recommended condensate piping configurations are shown here:

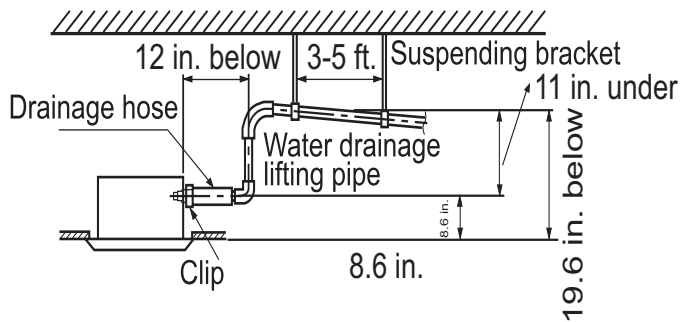

Electrical Power

Follow all local codes and regulations when installing electrical wiring.

Route required electrical power to area where the Slim Duct unit is to be located. Maintain at least a 10 foot separation between TV and Radio wiring and the power to the indoor unit.

14 Gauge AWG stranded wire should be used to make the electrical connection between indoor and outdoor units. This wiring will serve to power the indoor unit and establish a communication link between indoor and outdoor units.

The wiring is connected at the indoor unit electrical terminal blocks screws 1, 2, 3 and ground. There should be no splices in the wires connected to terminals 1 or 3 as these serve as communication signal wires and electrical power connections. If a safety switch needs to be in place to shut off power to the indoor unit, break wire 2 only.

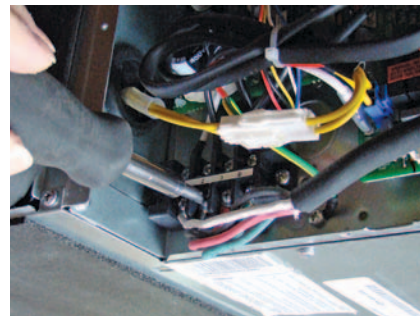

Air Delivery Clearances

Make certain to maintain proper clearances around the Slim Duct unit.

Inadequate clearances can cause system freezing and temperature control problems.

Service and Maintenance Clearances

Make sure there are adequate clearances for future maintenance and service. Allow enough room to access the condensate pump assembly and the electrical control box.

Step 1 - Preparation

Required Tools for Installation

- Drill
- Wire Snipper
- Hole Saw 2 3/4"
- Vacuum pump
- Soap-and-water solution or gas leakage detector
- Torque wrench
- 17mm, 22mm, 26mm
- Tubing cutter
- Flaring tool
- Razor knife
- Measuring tape
- Level
- Micron gauge
- Nitrogen
- Mini-Split AD-87 Adapter (1/4" to 5/16")
- A - Non-adhesive Tape
- B - Adhesive Tape
- C - Saddle (L.S.) with screws
- D - Electrical wiring
- E - Drain hose (Included)
- F - Insulation
- G - Piping hole cover (Included)

Procedure for Selecting the Location

- Place above the ceiling or in soffit area where you have enough space to position the unit.
- Place where the drainage pipe can be properly positioned.
- Place where the inlet and outlet air of the indoor unit will not be blocked.
- Do not install the unit in a place with heavy oil or moisture (e.g. - kitchens and workshops)
- Do not install in a location with destructive gas (such as sulfuric acid gas) or pungent gas (thinner and gasoline) are used or stored.
- Choose a place solid enough to bear the weight and vibration of the unit and where the operation noise will not be amplified.
- Install where there are no expensive items like a television or piano below the indoor unit.
- Leave enough space for maintenance.
- Install at least 3 ft. away from televisions and radios to avoid interference.

Note:

1) R-410A refrigerant is a safe, nontoxic and nonflammable refrigerant. However, if there is a concern about a dangerous level of refrigerant concentration in the case of refrigerant leakage, add extra ventilation.

Threaded Rod Mounting Information

The Slim Duct unit should be mounted to the building structure using threaded rods. The threaded rods should have washers and nuts to allow the height and level of the Slim Duct unit to be adjusted.

The threaded rods and attachment brackets are field supplied items. The materials required for mounting to the brackets on the Slim Duct unit include:

- 4- 3/8" Threaded Rods
- 4- Mounting Brackets
- Washers
- Nuts (Double nut the assembly as shown in steps 2.2 & 2.3)

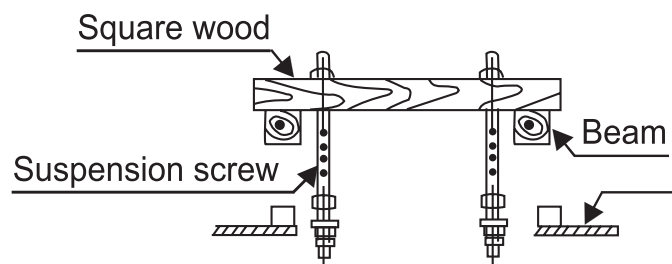
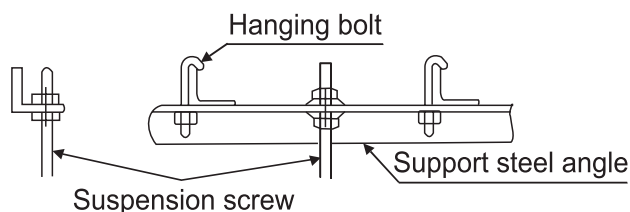
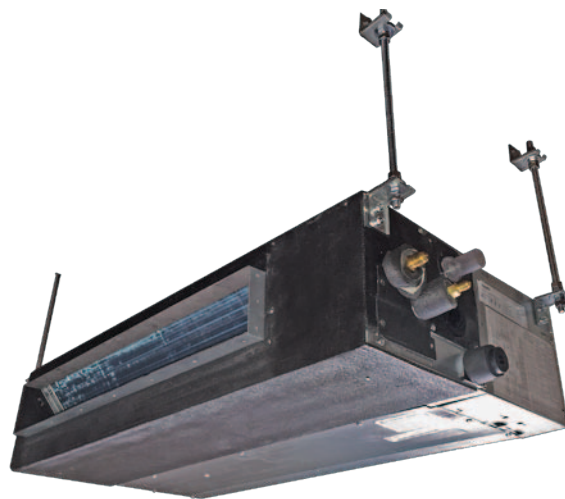

Step By Step Guide To Slim Duct Unit Installation

2.1 Step 2.1

Determine and mark the position of where the Slim Duct unit is to be installed. Install the hardware necessary to mount the threaded rods. Always select a location strong enough to support the indoor Slim Duct unit.

2.2 Step 2.2

Install the threaded rods to the hardware attached to the structure.

2.3 Step 2.3

Lift the Slim Duct unit and position the threaded rods into the 4 mounting clips, one located on each corner of the unit.

2.4 Step 2.4

Using a level, adjust the nuts on the threaded rods to obtain level readings both side to side and front to back on the Slim Duct unit.

2.5 Step 2.5 - 2.5A

Prior to routing the refrigerant lines to the unit, install the supplied flare nuts onto the refrigerant lines. Using a flaring tool, flare the refrigerant lines. Remove the caps attached to the ends of the refrigerant line connections at the Slim Duct unit. Holding gas should leak out. Attach the refrigerant lines to the air handler.

Using a torque wrench, torque the fittings to the proper specifications. (See Outdoor Unit Section for flare torque settings.)

2.6 Step 2.6

Connect the grey flexible drain hose supplied with the Slim Duct unit to the condensate pump discharge pipe of the Slim Duct unit. Tighten the clamp securely. Using 3/4" PVC, connect the flexible hose to the building's condensate drain system.

2.7 Steps 2.7 - 2.7A - 2.7B

Route the 14AWG stranded 4 conductor power/communication cable and the wired remote cable to the air handler. Use reducing washers and appropriate connector to attach the power/communication cable to the unit. The wired remote cable will enter the unit through a rubber grommet. The 4 conductor cable connects to the terminal block at terminals 1, 2, 3, and ground. The wired remote cable connects to the air handler main board at connector CN1. Re-install electrical box cover.

2.8 Step 2.8

The unit is now ready for connection to the ductwork. The return air duct can be configured as either a rear side inlet or bottom side inlet.

Step 2.1



Step 2.2



Step 2.3



Step 2.4



Step 2 - Installation of the Slim Duct Unit

Step 2.5



Step 2.7A

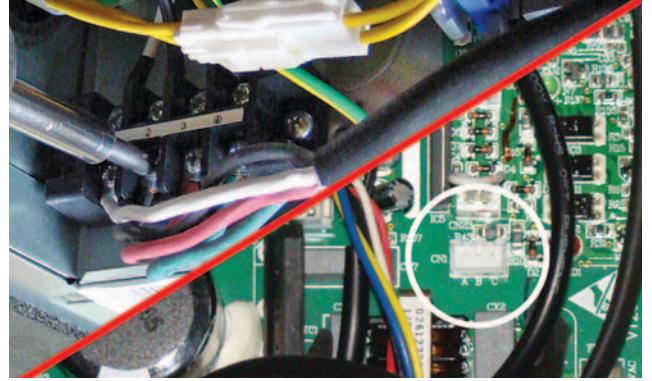

Step 2.5A



Step 2.7B
Re-install electrical box cover



Step 2.6

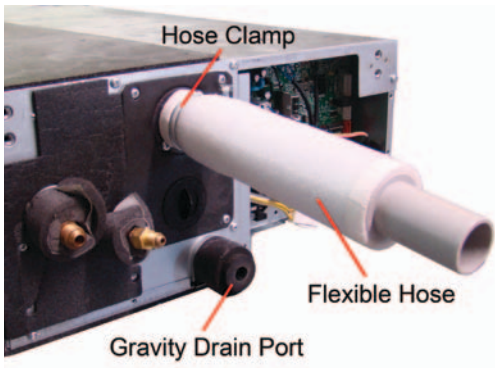

Step 2.8

Rear side air inlet

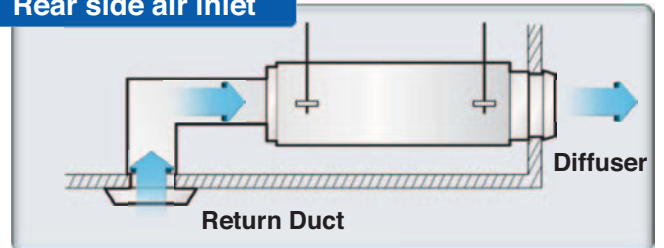

Bottom side air inlet

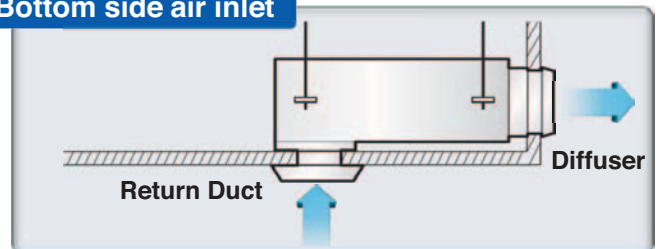

Step 2.7

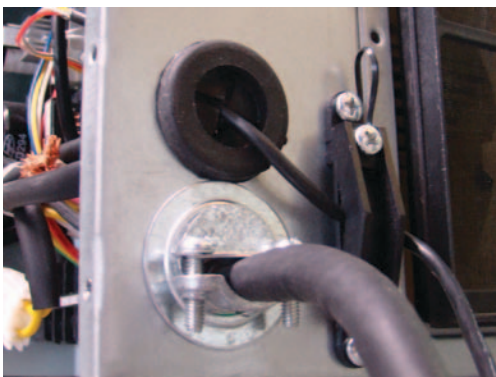

INSTALLATION IS NOW COMPLETE

Step 3 - Electrical Connections

Electrical Connections Indoor and Outdoor Units

14 AWG Stranded Wire Only. (Central Controller Not Used)

Maintain 10 feet of separation between TV and any Radio wiring.

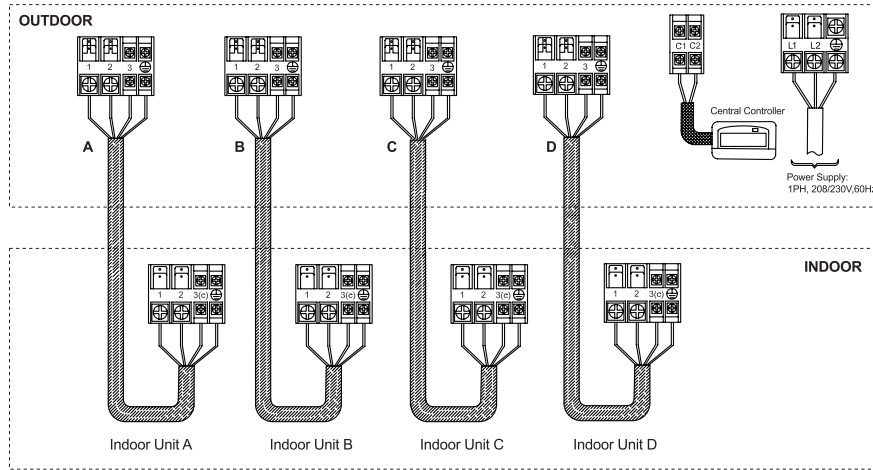

Step 4 - Pull Vacuum on System

See Step 4.2 of the outdoor unit installation section for how to pull a vacuum.

Indoor Slim Duct Unit Installation Complete

Remote Controller

Functions

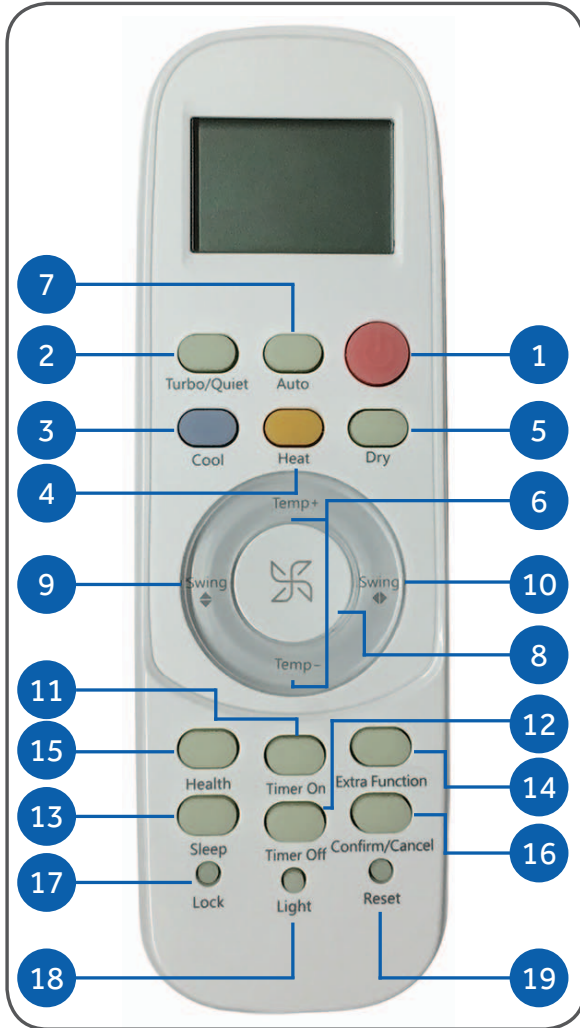





1 Power Button

Press the ON/OFF  button on the remote control to start the unit.

2 TURBO/QUIET Button

The TURBO function is used for fast heating or cooling.

Press the TURBO/QUIET  button once and the remote control will display the TURBO  icon on the bottom right side of the remote display and switch the unit to the TURBO function.

The QUIET function may be used when silence is needed for fast rest or reading. Press the TURBO/QUIET  button again to switch to QUIET mode and the remote control will display the QUIET  icon on the bottom left side of the remote display.

Press the TURBO/QUIET  button a third time to cancel TURBO/QUIET and return to normal operation.

Note:

TURBO/QUIET modes are only available when the unit is under cooling or heating mode (not for auto or fan mode).

Running the unit in QUIET mode for a long period of time may cause the room temperature to not reach the set temperature. If this occurs, cancel QUIET mode and set the fan speed to a higher setting.

3 COOL Button

In COOL mode, the unit operates in cooling. When FAN is set to AUTO, the air conditioner automatically adjusts the fan speed according to room temperature. The  will be displayed during COOL mode.

4 HEAT Button

In HEAT mode, warm air will blow out after a short period of the time due to cold-air prevention function. When FAN is set to AUTO, the air conditioner automatically adjusts the fan speed according to room temperature. The  will be displayed during HEAT mode.

5 DRY Button

DRY mode is used to reduce humidity. In DRY mode, when room temperature becomes lower than temp. setting +2°F, unit will run intermittently at LOW speed regardless of FAN setting. The  will be displayed during DRY mode.

6 Temperature +/- Buttons

Temp + Every time the button is pressed, the temperature setting increases.

Temp - Every time the button is pressed, temperature setting decreases.

The operating temperature range is 60°F-86°F.

7 AUTO Button

Under the mode of auto operation, the air conditioner will automatically select Cool, Heat, or Fan operation according to set temperature. When FAN is set to AUTO the air conditioner automatically adjusts the fan speed according to room temperature. The  will be displayed during AUTO mode.

8 FAN Button

Fan speed selection

Press the FAN  button. For each press, fan speed changes as follows:

Remote control:

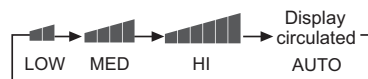

The air conditioner fan will run according to the displayed fan speed.

When FAN is set to AUTO, the air conditioner automatically adjusts the fan speed according to room temperature.

9 Louver SWING Button - Vertical

Air Flow Direction Adjustment

Press the SWING UP/DOWN button to choose the position of the vertical airflow louvers.

Status display of air flow

COOL/DRY:



HEAT:



Caution:

- It is advisable not to keep the vertical louver in the downward position for an extended period of time in COOL or DRY mode, otherwise condensate water may form on the louver.

Note:

When turning the unit on, the remote control will automatically return the louver to the previous set swing position. When turning the unit off, the louver will rotate to the full open position prior to closing.

10 Louver SWING Button - Horizontal

Press the SWING UP/DOWN button to choose the position of the horizontal airflow louvers.

Status display of air flow

COOL/DRY/HEAT:

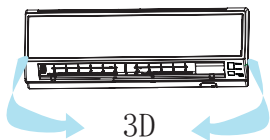
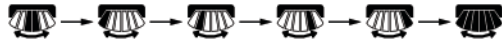

Caution:

- When humidity levels are high, condensate water may occur at the air outlet if all horizontal louvers are adjusted to left or right.

Note:

When turning the unit on, the remote control will automatically return the louver to the previous set swing position. When turning the unit off, the louver will rotate to the full open position prior to closing.

11 Timer ON Button

On-Off Operation

- Start the unit and select the desired operating mode.
- Press the TIMER ON button to enter the TIMER ON mode. The remote control will start flashing "ON".
- Every time the TIMER ON button is pressed the length of time increases in 0.5 hour increments between hours 0 and 12, and 1 hour increments for times between hours 12 and 24.
- Once the desired length of time is selected for the unit to turn on, press the CONFIRM/CANCEL button to confirm this setting.

The remote control display changes as follows:

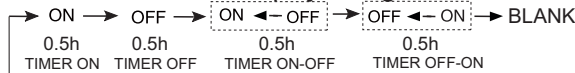

Cancel TIMER ON setting:

With a TIMER ON set, press the CONFIRM/CANCEL button once to cancel the TIMER ON.

Turning the unit ON with the TIMER from it being OFF will look like this on the remote control display:



Note:

Holding the TIMER ON button down will rapidly cycle the time. After replacing batteries or a power failure occurs, the time setting will need to be reset.

According to the Time setting sequence of TIMER ON or TIMER OFF, either Start-Stop or Stop-Start can be achieved.

12 Timer OFF Button

On-Off Operation

- Start the unit and select the desired operating mode.
- Press the TIMER OFF button to enter the TIMER OFF mode. The remote control will start flashing "OFF".
- Every time the TIMER OFF button is pressed the length of time decreases in 0.5 hour increments between hours 0 and 12, and 1 hour increments for times between hours 12 and 24.
- Once the desired length of time is selected for the unit to turn off, press the CONFIRM/CANCEL button to confirm this setting.

The remote control display changes as follows:

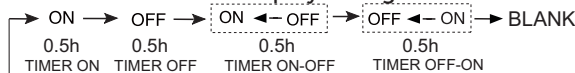

Cancel TIMER OFF setting:

With a TIMER OFF set, press the CONFIRM/CANCEL button once to cancel the TIMER OFF.

Turning the unit OFF with the TIMER from it being ON will look like this on the remote control display:



Note:





Holding the TIMER OFF button down will rapidly cycle

the time. After replacing batteries or a power failure occurs, the time setting will need to be reset.

According to the Time setting sequence of TIMER ON or TIMER OFF, either Start-Stop or Stop-Start can be achieved.

13 SLEEP Button

Sleep mode

Press the Extra Function  button to enter additional options, cycle the button to display the  icon, the  icon will flash. Press the Confirm/Cancel  button to enter the sleep function.

Sleep Operation Mode

1. SLEEP mode during COOL, DRY modes

One hour after SLEEP mode starts, the temperature will rise 2°F above set temperature, after another hour, the temperature rises an additional 2°F. The unit will run for an additional six hours, then turns off. The final temperature is 4°F higher than the initial set temperature. Using this feature will help with achieving maximum efficiency and comfort from your unit while you sleep.

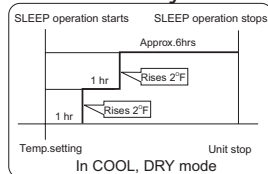

2. SLEEP mode during HEAT mode

One hour after SLEEP mode starts, the temperature will decrease 4°F below set temperature, after another hour, the temperature will decrease an additional 4°F. After an additional three hours, the temperature will rise by 2°F. The unit will run for an additional three hours, then turns off. The final temperature is 6°F lower than the initial set temperature. Using this feature will help with achieving maximum efficiency and comfort from your unit while you sleep.

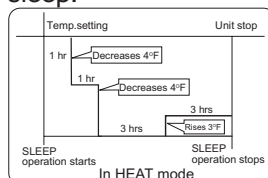

3. In AUTO mode

The unit operates in corresponding sleep mode adapted to the automatically selected operation mode.

Note:

- When the unit is set to sleep mode, the fan speed will be set to low speed and cannot be changed.
- When the TIMER function is set, the sleeping function cannot be set. If the sleeping function has been set, and the user sets the TIMER function, the sleeping function will be canceled, and the unit will be set to the timer function.

14 EXTRA FUNCTION Button

Function:

A) Refresh air - Feature not available on this series.

B) A-B Yard - This will allow you to control two separate units with a single remote control.

Note: this feature would be setup at the time of installation by the contractor.

C) Fan Mode - Is indicated by the  icon. Only the fan will operate in this mode. See section 8 "FAN Button" for changing the fan settings.

D) Intelligent upward airflow, E) Intelligent downward airflow, F) Reset intelligent airflow position

1. Press the ON/OFF button on the remote control to turn the unit on.

Select the desired operating mode.



2. Setting the intelligent airflow function

Press the EXTRA FUNCTION  button to enter additional options. Press this button repeatedly to access the louver settings. The louver icon will cycle through the following three settings.





Select the desired position, then press the CONFIRM/CANCEL  button to set the function.

3. Canceling the intelligent airflow function



Press the EXTRA FUNCTION  button to enter additional options. Press this button repeatedly to access the louver settings. Cycle the button to the louver icon "present" position, then press the CONFIRM/CANCEL  button to cancel the function.

Notice: Do not reposition the horizontal louver by hand. This may cause the louver to run incorrectly and not match the icon displayed on the remote control. If the louver is not running correctly, turn the unit off for one minute, then back on, and adjust the louver setting with the remote control.

Note:

1. After setting the intelligent airflow function, the louver position is fixed.
2. In cooling, it is better to select the  mode.
3. In heating, it is better to select the  mode.
4. In cooling and dry modes, using the air conditioner for a long period of time under high humidity conditions, condensate water may form on the grille/louver.

G) Fahrenheit/Celsius mode shift on unit and remote -

To switch between Fahrenheit and Celsius press the EXTRA FUNCTION  button until either Celsius or Fahrenheit is displayed. Press the CONFIRM/CANCEL  button to apply the change.

H) 50°F low temperature heating - Feature not available on this series.

I) Electrical heating - Feature not available on this series.

15 HEALTH Button

Feature not available on this series.

16 Confirm/Cancel Button

Function: Setting and canceling timer and other functions.

17 LOCK Button

Used to lock buttons and LCD display

18 LIGHT Button

Turns indoor unit display on and off

19 RESET Button

If the remote control is not functioning properly, use a pen point or similar object to depress this button to reset the remote.

www.Haier.com

Model #: 2U18MS2VHB, 3U24MS2VHB,
4U36MS2VHB, AW07LC2VH*, AW09LC2VH*,
AW12LC2VH*, AW18LC2VH*, AD07SL2VH*,
AD09SL2VH*, AD12SL2VH*, AD18SL2VH*
Issued Date: June 2016

Haier America,
Wayne, NJ 07470
©2016 Haier America Trading, LLC.