

24" (61 cm) Electric & 27" (69 cm) Electric and Gas Washer/Dryer Installation Instructions

Instructions pour l'installation de la laveuse/sécheuse électrique de 24" (61 cm) et électrique et à gaz de 27" (69 cm)

Instrucciones de instalación de la lavadora/secadora eléctrica de 24" (61 cm) y eléctrica y de gas de 27" (69 cm)

Table of Contents

WASHER/DRYER SAFETY	2
INSTALLATION REQUIREMENTS.....	5
LOCATION REQUIREMENTS.....	7
DIMENSIONS/CLEARANCES, 27" (69 CM) MODELS	8
DIMENSIONS/CLEARANCES, 24" (61 CM) MODELS	9
DRAIN SYSTEM	10
ELECTRICAL REQUIREMENTS, 240V ELECTRIC MODELS – U.S.A.	11
ELECTRICAL REQUIREMENTS, 120V ELECTRIC MODELS – U.S.A. AND CANADA (24" [61 CM] MODELS ONLY)	12
ELECTRICAL REQUIREMENTS, 240V ELECTRIC MODELS – CANADA.....	12
ELECTRICAL REQUIREMENTS, GAS MODELS (27" [69 CM] MODELS ONLY)	13
GAS SUPPLY REQUIREMENTS, GAS MODELS (27" [69 CM] MODELS ONLY)	13
REMOVE FOAM PACKING (24" [61 CM] MODELS)	14
ELECTRICAL CONNECTION, 27" (69 CM) ELECTRIC MODELS (U.S.A. ONLY)	15
ELECTRICAL CONNECTION, 24" (61 CM) 240V ELECTRIC MODELS (U.S.A. ONLY)	21
VENTING	25
CONNECT DRAIN HOSE.....	28
CONNECT INLET HOSES.....	29
MAKE GAS CONNECTION (GAS 27" [69 CM] MODELS ONLY)	30
CONNECT VENT	31
FINAL INSTALLATION STEPS.....	32
COMPLETE INSTALLATION CHECKLIST	35

Table des matières

SÉCURITÉ DE LA LAVEUSE/SÉCHEUSE	36
EXIGENCES D'INSTALLATION	39
EXIGENCES D'EMPLACEMENT	41
DIMENSIONS/DISTANCES DE DÉGAGEMENT, MODÈLES DE 27" (69 CM).....	42
DIMENSIONS/DISTANCES DE DÉGAGEMENT, MODÈLES DE 24" (61 CM).....	43
SYSTÈME DE VIDANGE	44
SPÉCIFICATIONS ÉLECTRIQUES, MODÈLES ÉLECTRIQUES DE 120V (MODÈLES DE 24" [61 CM] UNIQUEMENT – CANADA.....	45
SPÉCIFICATIONS ÉLECTRIQUES, MODÈLES ÉLECTRIQUES DE 240V – CANADA	45
SPÉCIFICATIONS ÉLECTRIQUES, MODÈLES À GAZ (MODÈLES DE 27" [69 CM] UNIQUEMENT).....	46
SPÉCIFICATIONS DE L'ALIMENTATION EN GAZ, MODÈLES À GAZ (MODÈLES DE 27" [69 CM] UNIQUEMENT).....	47
ENLEVER L'EMBALLAGE EN MOUSSE (MODÈLES DE 24" [61 CM]).....	48
ÉVACUATION	49
RACCORDEMENT DU TUYAU DE VIDANGE.....	52
RACCORDEMENT DES TUYAUX D'ARRIVÉE D'EAU	53
RACCORDEMENT À LA CANALISATION DE GAZ (MODÈLES À GAZ DE 27" [69 CM] UNIQUEMENT).....	54
RACCORDEMENT DU CONDUIT D'ÉVACUATION	55
ÉTAPES D'INSTALLATION FINALES	56
LISTE DE VÉRIFICATION POUR L'ACHÈVEMENT DE L'INSTALLATION	59

Índice

SEGURIDAD DE LA LAVADORA/SECADORA	60
REQUISITOS DE INSTALACIÓN	63
REQUISITOS DE UBICACIÓN.....	65
DIMENSIONES Y ESPACIOS LIBRES, MODELOS DE 27" (69 CM)	66
DIMENSIONES Y ESPACIOS LIBRES, MODELOS DE 24" (61 CM)	67
SISTEMA DE DESAGÜE.....	68
REQUISITOS ELÉCTRICOS, MODELOS ELÉCTRICOS DE 240V.....	69
REQUISITOS ELÉCTRICOS, MODELOS ELÉCTRICOS DE 120V (MODELOS DE 24" [61 CM] SOLAMENTE).....	70
REQUISITOS ELÉCTRICOS, MODELOS A GAS (MODELOS DE 27" [69 CM] SOLAMENTE).....	71
REQUISITOS DEL SUMINISTRO DE GAS, MODELOS A GAS (MODELOS DE 27" [69 CM] SOLAMENTE).....	72

QUITE EL EMBALAJE DE HULE ESPUMA (MODELOS DE 24" [61 CM]).....	73
CONEXIÓN ELÉCTRICA, MODELOS ELÉCTRICOS DE 27" (69 CM) (EE.UU. SOLAMENTE)	74
CONEXIÓN ELÉCTRICA, MODELOS ELÉCTRICOS DE 24" (61 CM) DE 240V (EE.UU. SOLAMENTE).....	80
VENTILACIÓN	84
CONECTE LA MANGUERA DE DESAGÜE.....	87
CONECTE LAS MANGUERAS DE ENTRADA	88
CONEXIÓN DEL SUMINISTRO DE GAS (MODELOS A GAS DE 27" [69 CM] SOLAMENTE)	89
CONECTE EL DUCTO DE ESCAPE.....	90
PASOS FINALES DE INSTALACIÓN	91
LISTA DE CONTROL PARA LA REALIZACIÓN DE LA INSTALACIÓN.....	94

INSTALLATION NOTES

Date of purchase: _____
Date of installation: _____
Installer: _____
Model number: _____
Serial number: _____

NOTES CONCERNANT L'INSTALLATION

Date d'achat : _____
Date d'installation : _____
Installateur : _____
Numéro de modèle : _____
Numéro de série : _____

NOTAS DE INSTALACIÓN

Fecha de la compra: _____
Fecha de la instalación: _____
Instalador: _____
Número de modelo: _____
Número de serie: _____



Washer/Dryer Safety

Your safety and the safety of others are very important.

We have provided many important safety messages in this manual and on your appliance. Always read and obey all safety messages.



This is the safety alert symbol.

This symbol alerts you to potential hazards that can kill or hurt you and others.

All safety messages will follow the safety alert symbol and either the word “DANGER” or “WARNING.” These words mean:

⚠ DANGER

You can be killed or seriously injured if you don't immediately follow instructions.

⚠ WARNING

You can be killed or seriously injured if you don't follow instructions.

All safety messages will tell you what the potential hazard is, tell you how to reduce the chance of injury, and tell you what can happen if the instructions are not followed.



WARNING - “Risk of Fire”

- Clothes dryer installation must be performed by a qualified installer.
- Install the clothes dryer according to the manufacturer's instructions and local codes.
- Do not install a clothes dryer with flexible plastic venting materials or flexible metal (foil type) duct. If flexible metal duct is installed, it must be of a specific type identified by the appliance manufacturer as suitable for use with clothes dryers. Flexible venting materials are known to collapse, be easily crushed, and trap lint. These conditions will obstruct clothes dryer airflow and increase the risk of fire.
- To reduce the risk of severe injury or death, follow all installation instructions.
- Save these instructions.

⚠ WARNING

Fire Hazard

Failure to follow safety warnings exactly could result in serious injury, death, or property damage.

Do not install a booster fan in the exhaust duct.

Install all clothes dryers in accordance with the installation instructions of the manufacturer of the dryer.

 **WARNING:**

FIRE OR EXPLOSION HAZARD

Failure to follow safety warnings exactly could result in serious injury, death, or property damage.

- Do not store or use gasoline or other flammable vapors and liquids in the vicinity of this or any other appliance.
- **WHAT TO DO IF YOU SMELL GAS:**
 - Do not try to light any appliance.
 - Do not touch any electrical switch; do not use any phone in your building.
 - Clear the room, building, or area of all occupants.
 - Immediately call your gas supplier from a neighbor's phone. Follow the gas supplier's instructions.
 - If you cannot reach your gas supplier, call the fire department.
- Installation and service must be performed by a qualified installer, service agency, or the gas supplier.

WARNING: Gas leaks cannot always be detected by smell.

Gas suppliers recommend that you use a gas detector approved by UL or CSA.

For more information, contact your gas supplier.

If a gas leak is detected, follow the "What to do if you smell gas" instructions.

In the State of Massachusetts, the following installation instructions apply:

- Installations and repairs must be performed by a qualified or licensed contractor, plumber, or gas fitter qualified or licensed by the State of Massachusetts.
- Acceptable Shut-off Devices: Gas Cocks and Ball Valves installed for use shall be listed.
- A flexible gas connector, when used, must not exceed 4 feet (121.9 cm).

IMPORTANT: The gas installation must conform with local codes, or in the absence of local codes, with the National Fuel Gas Code, ANSI Z223.1/NFPA 54, or the Natural Gas and Propane Installation Code, CSA B149.1.

The dryer must be electrically grounded in accordance with local codes, or in the absence of local codes, with the National Electrical Code, ANSI/NFPA 70, or the Canadian Electrical Code, Part 1, CSA C22.1.

IMPORTANT SAFETY INSTRUCTIONS

WARNING: To reduce the risk of fire, electric shock, or injury to persons when using the washer/dryer, follow basic precautions, including the following:

- Read all instructions before using the washer/dryer.
- Do not place items exposed to cooking oils in your dryer. Items contaminated with cooking oils may contribute to a chemical reaction that could cause a load to catch fire.
- To reduce the risk of fire due to contaminated loads, the final part of a tumble dryer cycle occurs without heat (cool down period). Avoid stopping a tumble dryer before the end of the drying cycle unless all items are quickly removed and spread out so that the heat is dissipated.
- Do not wash or dry articles that have been previously cleaned in, washed in, soaked in, or spotted with gasoline, dry-cleaning solvents, or other flammable or explosive substances as they give off vapors that could ignite or explode.
- Do not add gasoline, dry-cleaning solvents, or other flammable or explosive substances to the wash water. These substances give off vapors that could ignite or explode.
- Do not allow children to play on or in the washer/dryer. Close supervision of children is necessary when the washer/dryer is used near children.
- Before the washer/dryer is removed from service or discarded, remove the doors to the washer/dryer compartments.
- Do not reach into the washer/dryer if the tub, agitator, or drum is moving.
- Do not install or store the washer/dryer where it will be exposed to the weather.
- Do not tamper with controls.
- Clean dryer lint screen before or after each load.
- Under certain conditions, hydrogen gas may be produced in a hot water system that has not been used for 2 weeks or more. **HYDROGEN GAS IS EXPLOSIVE.** If the hot water system has not been used for such a period, before using the washing machine, turn on all hot water faucets and let the water flow from each for several minutes. This will release any accumulated hydrogen gas. As the gas is flammable, do not smoke or use an open flame during this time.
- Do not repair or replace any part of the washer/dryer or attempt any servicing unless specifically recommended in this Use and Care Guide or in published user-repair instructions that you understand and have the skills to carry out.
- Do not use fabric softeners or products to eliminate static unless recommended by the manufacturer of the fabric softener or product.
- Do not use heat to dry articles containing foam rubber or similarly textured rubber-like materials.
- Keep area around the exhaust opening and adjacent surrounding areas free from the accumulation of lint, dust, and dirt.
- The interior of the machine and dryer exhaust vent should be cleaned periodically by qualified service personnel.
- See “Electrical Requirements” section of the Installation Instructions booklet for grounding instructions.

SAVE THESE INSTRUCTIONS

State of California Proposition 65 Warnings:

WARNING: This product contains one or more chemicals known to the State of California to cause cancer.

WARNING: This product contains one or more chemicals known to the State of California to cause birth defects or other reproductive harm.

IMPORTANT SAFETY INSTRUCTIONS

When discarding or storing your old clothes dryer, remove the door.

SAVE THESE INSTRUCTIONS

Installation Requirements

Tools and Parts

Gather required tools and parts before starting installation.

Tools needed:

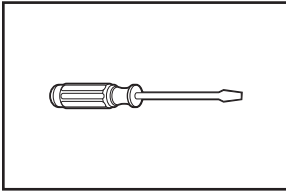

Flat-blade screwdriver

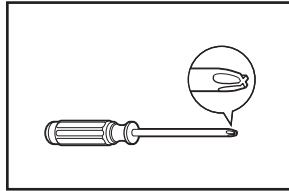

#2 Phillips screwdriver

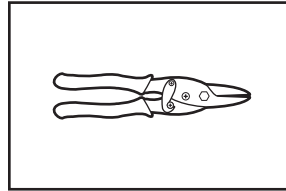

Tin snips (new vent installations)

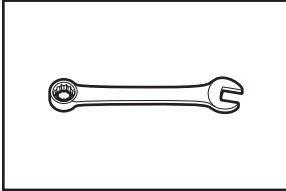

Adjustable or open-end wrench 9/16" (14 mm)

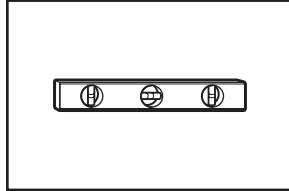

Level

Tools needed for gas installations:

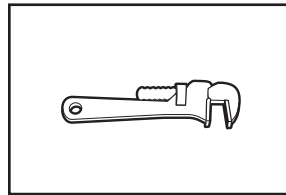

8" (203 mm) or 10" (254 mm) pipe wrench

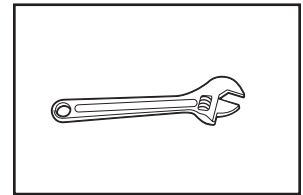

8" (203 mm) or 10" (254 mm) adjustable wrench (for gas connections)

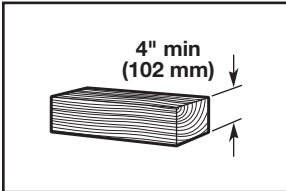

Wood block

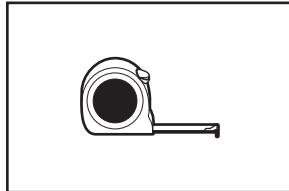

Ruler or measuring tape

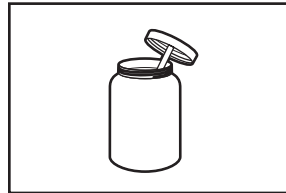

Pipe-joint compound resistant to propane gas

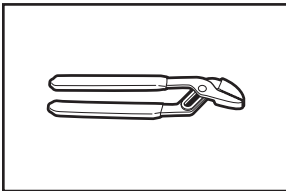

Pliers that open to 1 9/16" (39.5 mm)

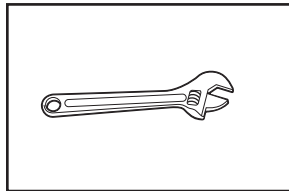

Adjustable wrench that opens to 1" (25 mm) or hex-head socket wrench

Optional tools:

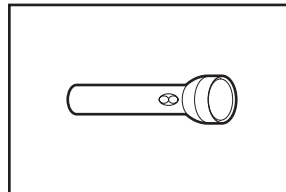

Flashlight

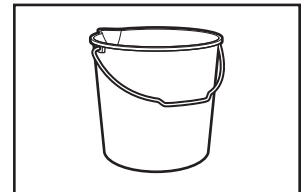

Bucket

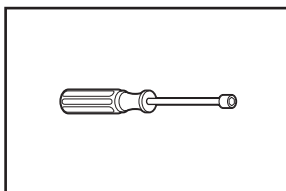

1/4" (6.5 mm) nut driver (recommended)

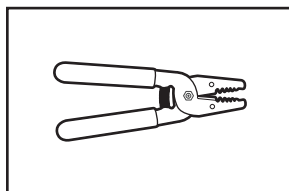

Wire stripper

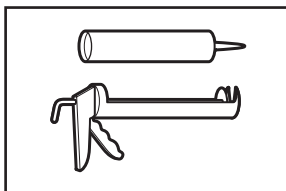

Caulking gun and compound (new vent installations)

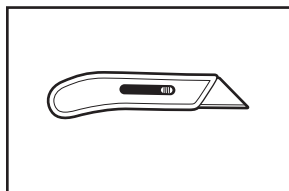

Utility knife

Parts supplied:

NOTE: Remove parts package from the washer basket. Check that all parts were included.

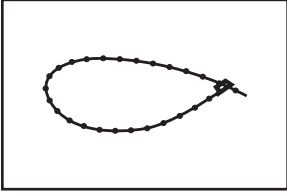

Plastic strap

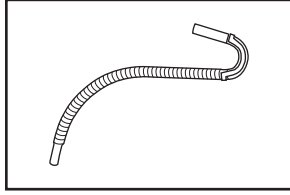

Drain hose

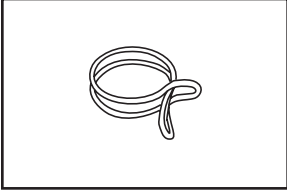

Silver double-wire hose clamp

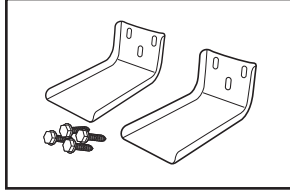

Anti-tip brackets (2) and screws (4) (27" [69 cm] models)

Parts needed: (Not supplied with washer/dryer)

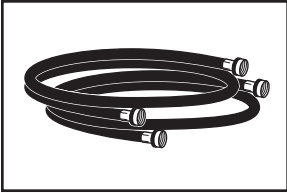

Inlet hoses with flat washers

- Vent clamps
- Vent elbows and ductwork
- Mobile Home Installation Kit (Part Number 346764)
- Metal exhaust system hardware

Check local codes, electrical supply and venting, and read "Electrical Requirements" and "Venting Requirements" before purchasing parts. Mobile home installations require metal exhaust system hardware available for purchase from the dealer from whom you purchased your washer/dryer. For further information, please reference the "Assistance or Service" section of the Washer/Dryer Use and Care Guide.

Optional equipment: (Not supplied with washer/dryer)

Refer to your Use and Care Guide for information about accessories available for your washer/dryer.

Alternate parts: (Not supplied with washer/dryer)

Your installation may require additional parts. To order, please refer to the toll-free numbers on the back page of your Use and Care Guide.

If you have:

Overhead sewer

Floor drain

1" (25 mm) standpipe

Laundry tub or standpipe taller than 96" (2.4 m)

Drain hose too short

Lint clogged drain

Water faucets beyond reach of fill hoses

You will need:

Standard 20 gal. (76 L) 39" (991 mm) tall Drain Tub or Utility Sink, Sump Pump and Connectors (available from local plumbing suppliers)

Siphon Break Part Number 285320, Additional Drain Hose Part Number 285702, and Connector Kit Part Number 285442

2" (51 mm) diameter to 1" (25 mm) diameter Standpipe Adapter Part Number 3363920, Connector Kit Part Number 285835

Sump pump system (if not already available)

Extension Drain Hose Part Number 285863, Connector Kit Part Number 285835

Drain Protector Part Number 367031, Connector Kit Part Number 285835

Two longer water fill hoses:
6 ft (1.8 m) Part Number 76314,
10 ft (3.0 m) Part Number 350008

Location Requirements

⚠ WARNING



Explosion Hazard

Keep flammable materials and vapors, such as gasoline, away from dryer.

Do not install in a garage.

Failure to do so can result in death, explosion, or fire.

Select proper location for your washer/dryer to improve performance and minimize noise and possible “washer walk.” Install your washer/dryer in a basement, laundry room, closet, or recessed area.

You will need:

- A location that allows for proper exhaust installation. A washer/dryer must be exhausted to the outdoors. See “Venting Requirements.”
- For 27" (69 cm) and 24" (61 cm) 240V electric models, a separate 30 amp circuit. For 24" (61 cm) 120V electric models, a separate 20 amp circuit. For gas models, a separate 120V 15 or 20 amp circuit.
- For 27" (69 cm) electric models using a power supply cord, for 24" (61 cm) electric models, and for gas models, a grounded electrical outlet located within 2 ft (610 mm) of either side of the washer/ dryer. See “Electrical Requirements.”
- A sturdy floor to support the washer/dryer weight (washer/ dryer, water, and load) of 500 lbs (226.8 kg).
- A level floor with a maximum slope of 1" (25 mm) under entire washer/dryer. Clothes may not tumble properly and automatic sensor cycles may not operate correctly if washer/dryer is not level. Installing on carpet is not recommended.
- A water heater set to deliver 120°F (49°C) water to the washer.
- Hot and cold water faucets located within 4 ft (1.2 m) of the hot and cold water fill valves, and water pressure of 5–100 psi (34.5–689.6 kPa).

The washer/dryer must not be installed or stored in an area where it will be exposed to water and/or weather.

Do not operate your washer in temperatures at or below 32°F (0°C). Some water can remain in the washer and can cause damage in low temperatures. See “Washer/Dryer Care” in the Washer/Dryer Use and Care Guide for winterizing information.

Do not operate your dryer at temperatures below 45°F (7°C). At lower temperatures, the dryer might not shut off at the end of an automatic cycle. This can result in longer drying times.

Check code requirements. Some codes limit, or do not permit, installation of the washer/dryer in garages, closets, mobile homes, or sleeping quarters. Contact your local building inspector.

Recessed area or closet installation

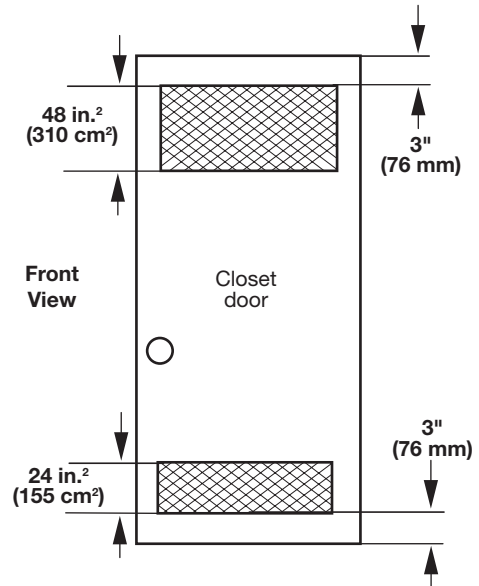

The spacing dimensions on the following pages are recommended for this washer/dryer. This washer/dryer has been tested for spacing of 0" (0 mm) clearance at the sides and back. Recommended spacing should be considered for the following reasons:

- Additional spacing should be considered for ease of installation and servicing.
- Additional clearances might be required for wall, door, and floor moldings.
- Additional spacing on all sides of the washer/dryer is recommended to reduce noise transfer.
- For closet installation, with a door, minimum ventilation openings in the top and bottom of the door are required. Louvered doors with equivalent ventilation openings are acceptable.

NOTE: For gas models, no other fuel-burning appliance can be installed in the same closet as the washer/dryer.

Mobile Home – Additional Installation Requirements

This washer/dryer is suitable for mobile home installations. The installation must conform to the Manufactured Home Construction and Safety Standard, Title 24 CFR, Part 3280 (formerly the Federal Standard for Mobile Home Construction and Safety, Title 24, HUD Part 280) or the Canadian Manufactured Home Standard, CAN/CSA-Z240 MH.

Mobile home installations require:

- Metal exhaust system hardware, which is available for purchase from your dealer.
- Mobile Home Installation Kit Part Number 346764 (gas models only). See “Tools and Parts” for ordering information.
- Special provisions must be made in mobile homes to introduce outside air into the dryer. The opening (such as a nearby window) should be at least twice as large as the dryer exhaust opening.

Dimensions/Clearances, 27" (69 cm) Models

Dimensions

Front View

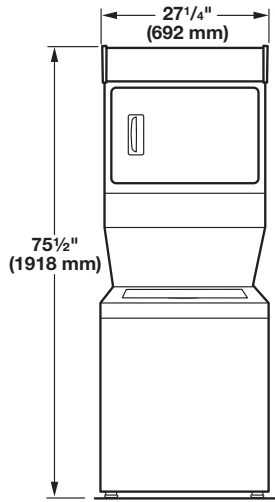

Side View

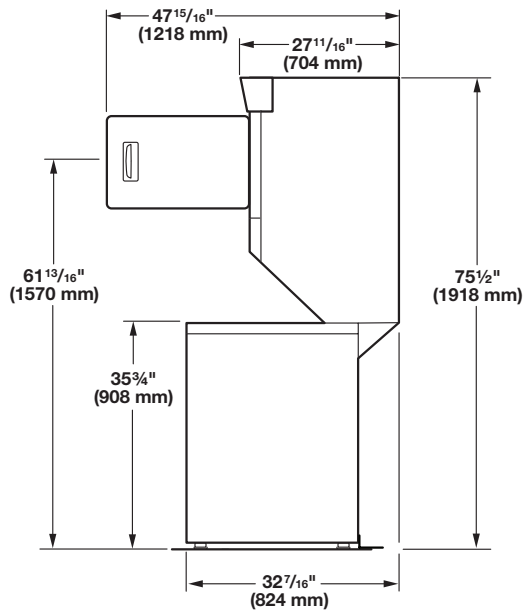

Back View

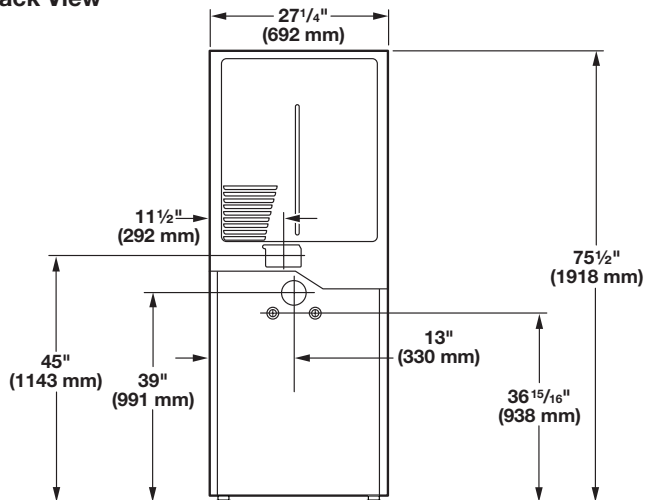

Clearances

Side Clearances (recommended/minimum)

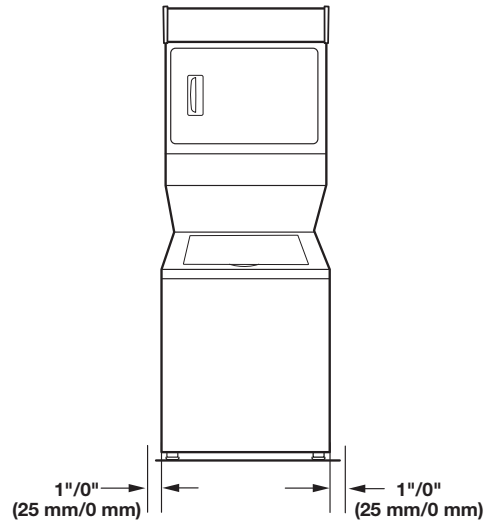

Front/Back/Top Clearances (recommended/minimum)

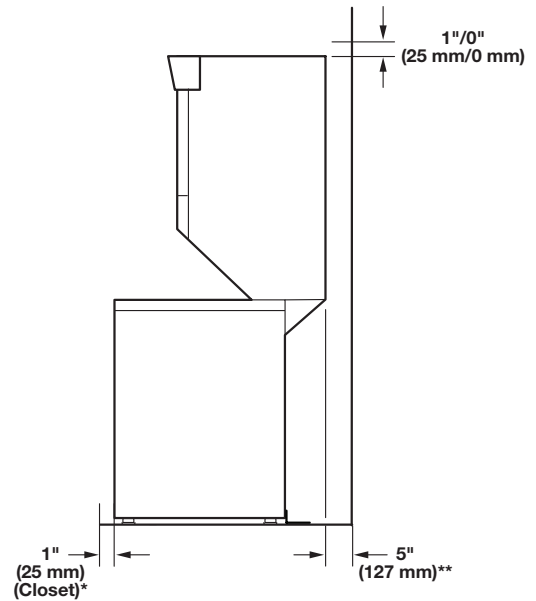

*Required spacing.

**Rear clearance may be 0" (0 mm) when house exhaust system is lined up directly with dryer exhaust.

Dimensions/Clearances, 24" (61 cm) Models

Dimensions

Front View

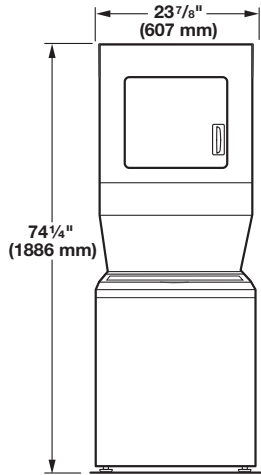

Clearances

Side Clearances (recommended/minimum)

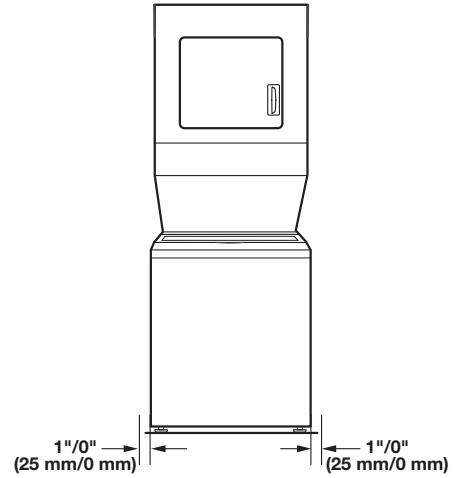

Side View

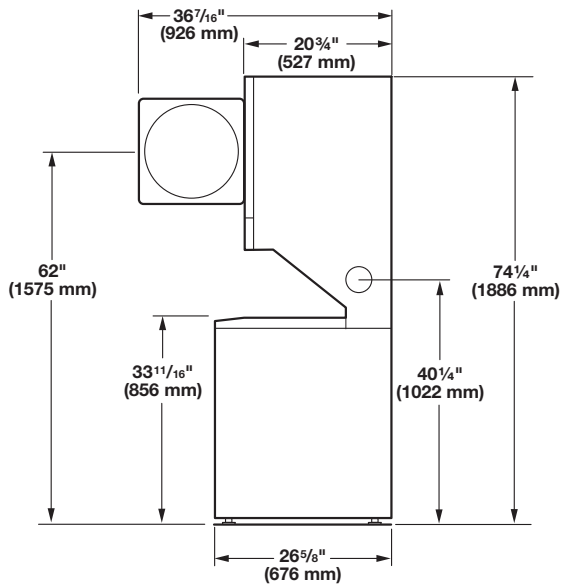

Front/Back/Top Clearances

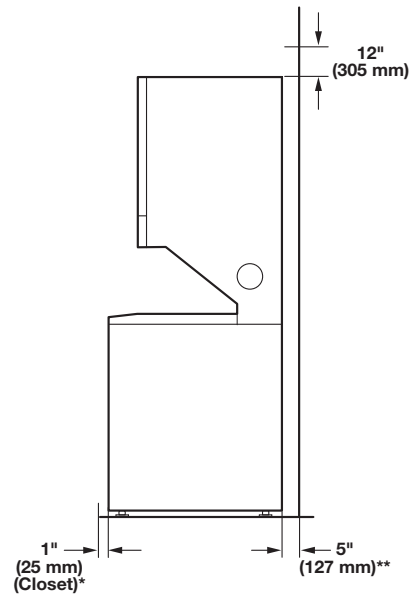

Back View

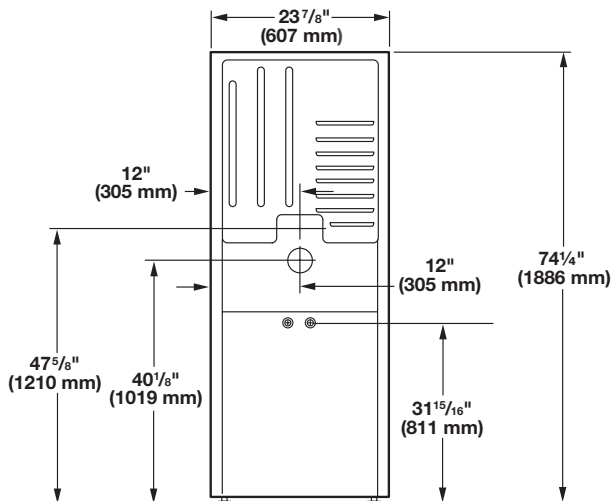

*Required spacing.

**Rear clearance may be 0" (0 mm) when house exhaust system is lined up directly with dryer exhaust.

Drain System

Drain system can be installed using a floor drain, wall standpipe, floor standpipe, or laundry tub. Select method you need.

Floor standpipe drain system

Minimum diameter for a standpipe drain: 2" (51 mm). Minimum carry-away capacity: 17 gal. (64 L) per minute. Top of standpipe must be at least 39" (991 mm) high; install no higher than 96" (2.4 m) from bottom of washer/dryer. If you must install higher than 96" (2.4 m), you will need a sump pump system.

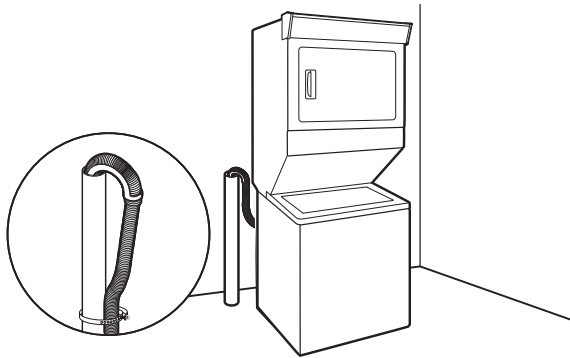

Wall standpipe drain system

See requirements for floor standpipe drain system.

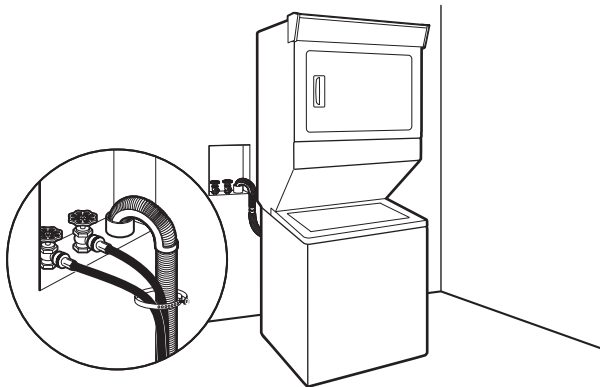

Floor drain system

Floor drain system requires a Siphon Break Kit (Part Number 285834), two Connector Kits (Part Number 285385), and an Extension Drain Hose (Part Number 285863) that may be purchased separately. To order, please see toll-free phone numbers in your Use and Care Guide. Minimum siphon break: 28" (710 mm) from bottom of washer/dryer. (Additional hoses may be needed.)

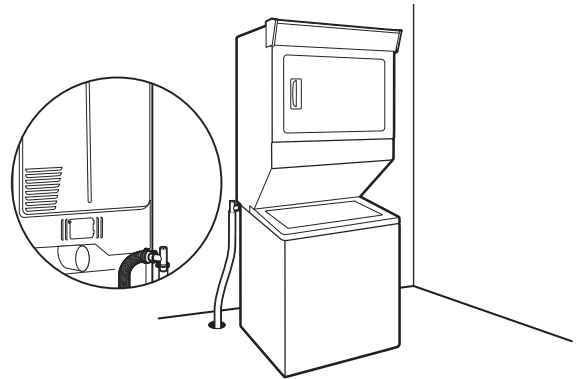

Laundry tub drain system

Minimum capacity: 20 gal. (76 L). Top of laundry tub must be at least 39" (991 mm) above floor on 27" (69 cm) models, or 34" (864 mm) above floor on 24" (61 cm) models; install no higher than 96" (2.4 m) from bottom of washer/dryer.

IMPORTANT: To avoid siphoning, no more than 4.5" (114 mm) of drain hose should be inside standpipe or below the top of wash tub. Secure drain hose with plastic strap.

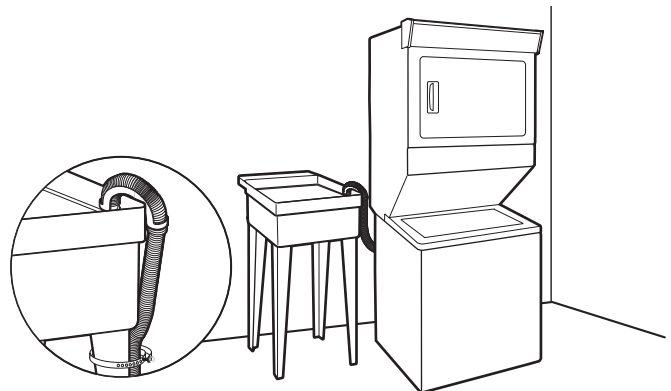

Electrical Requirements, 240V Electric Models – U.S.A.

⚠ WARNING



Electrical Shock Hazard

Plug into a grounded 3 or 4 prong outlet.

Do not remove ground prong.

Do not use an adapter.

Do not use an extension cord.

Failure to follow these instructions can result in death, fire, or electrical shock.

- It is recommended that a separate circuit breaker serving only this appliance be provided.
- To minimize possible shock hazard, the cord must be plugged into a mating, 3 or 4 prong, grounding-type outlet, grounded in accordance with local codes and ordinances. If a mating outlet is not available, it is the personal responsibility and obligation of the customer to have the properly grounded outlet installed by a qualified electrician.
- If codes permit and a separate ground wire is used, it is recommended that a qualified electrician determine that the ground path is adequate.
- Check with a qualified electrician if you are not sure the washer/dryer is properly grounded.
- Do not have a fuse in the neutral or ground circuit.

It is your responsibility:

- To contact a qualified electrical installer.
- To be sure that the electrical connection is adequate and in conformance with the National Electrical Code, ANSI/NFPA 70 – latest edition and all local codes and ordinances. A copy of the above code standards can be obtained from: National Fire Protection Association, One Batterymarch Park, Quincy, MA 02269.
- To supply the required 3- or 4-wire, single phase, 120/240 volt, 60 Hz., AC only electrical supply (or 3- or 4-wire, 120/208 volt electrical supply, if specified on the serial/rating plate) on a separate 30 amp circuit, fused on both sides of the line. A time-delay fuse or circuit breaker is recommended. Connect to an individual branch circuit.
- Do not use an extension cord.

Electrical Connection

To properly install your washer/dryer, you must determine the type of electrical connection you will be using and follow the instructions provided for it here.

- This washer/dryer is manufactured ready to install with a 3-wire electrical supply connection. The neutral ground wire is permanently connected to the neutral conductor (white wire) within the dryer. If the dryer is installed with a 4-wire electrical supply connection, the neutral ground wire must be removed from the external ground connector (green screw), and secured under the neutral terminal (center or white wire) of the terminal block. When the neutral ground wire is secured under the neutral terminal (center or white wire) of the terminal block, the dryer cabinet is isolated from the neutral conductor.
- If local codes do not permit the connection of a neutral ground wire to the neutral wire, see “Optional 3-wire connection” in the “Electrical Connection” section.
- A 4-wire power supply connection must be used when the appliance is installed in a location where grounding through the neutral conductor is prohibited. Grounding through the neutral is prohibited for (1) new branch-circuit installations, (2) mobile homes, (3) recreational vehicles, and (4) areas where local codes prohibit grounding through the neutral conductors.

If using a power supply cord:

Use a UL Listed power supply cord kit marked for use with clothes dryers. The kit should contain:

- A UL Listed 30 amp power supply cord, rated 120/240 volt minimum. The cord should be type SRD or SRDT and be at least 4 ft (1.22 m) long. The wires that connect to the dryer must end in ring terminals or spade terminals with upturned ends.
- A UL Listed strain relief.

If your outlet looks like this:



4-wire
receptacle
(14-30R)

Then choose a 4-wire power supply cord with ring or spade terminals and UL Listed strain relief. The 4-wire power supply cord, at least 4 ft (1.22 m) long, must have four 10-gauge copper wires and match a 4-wire receptacle of NEMA Type 14-30R. The ground wire (ground conductor) may be either green or bare. The neutral conductor must be identified by a white cover.

If your outlet looks like this:

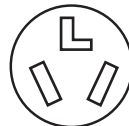

3-wire
receptacle
(10-30R)

Then choose a 3-wire power supply cord with ring or spade terminals and UL Listed strain relief. The 3-wire power supply cord, at least 4 ft (1.22 m) long, must have three 10-gauge copper wires and match a 3-wire receptacle of NEMA Type 10-30R.

If connecting by direct wire (27" [69 cm] models only):

Power supply cable must match power supply (4-wire or 3-wire) and be:

- Flexible armored cable or nonmetallic sheathed copper cable (with ground wire), covered with flexible metallic conduit. All current-carrying wires must be insulated.
- 10-gauge solid copper wire (do not use aluminum).
- At least 5 ft (1.52 m) long.

GROUNDING INSTRUCTIONS

For a grounded, cord-connected washer/dryer:

This washer/dryer must be grounded. In the event of a malfunction or breakdown, grounding will reduce the risk of electrical shock by providing a path of least resistance for electric current. This washer/dryer is equipped with a cord having an equipment-grounding conductor and a grounding plug. The plug must be plugged into an appropriate outlet that is properly installed and grounded in accordance with all local codes and ordinances.

WARNING: Improper connection of the equipment-grounding conductor can result in a risk of electric shock. Check with a qualified electrician or serviceman if you are in doubt as to whether the appliance is properly grounded.

Do not modify the plug provided with the appliance – if it will not fit the outlet, have a proper outlet installed by a qualified electrician.

For a permanently connected washer/dryer:

This washer/dryer must be connected to a grounded metal, permanent wiring system, or an equipment grounding conductor must be run with the circuit conductors and connected to the equipment-grounding terminal or lead on the appliance.

SAVE THESE INSTRUCTIONS

Electrical Requirements, 120V Electric Models – U.S.A. and Canada (24" [61 cm] Models Only)

- It is recommended that a separate circuit breaker serving only this appliance be provided.
- 120V models are equipped with a power supply cord having a 3 prong grounding plug intended to be plugged into a 20 amp 5-20R wall receptacle.
- To minimize possible shock hazard, the cord must be plugged into a mating, 3 prong, grounding-type outlet, grounded in accordance with local codes and ordinances. If a mating outlet is not available, it is the personal responsibility and obligation of the customer to have the properly grounded outlet installed by a qualified electrician.
- If codes permit and a separate ground wire is used, it is recommended that a qualified electrician determine that the ground path is adequate.
- Check with a qualified electrician if you are not sure the washer/dryer is properly grounded.
- Do not have a fuse in the neutral or ground circuit.
- 120 volt, 60 Hz, AC only, 20 amp fused electrical supply is required. A time-delay fuse or circuit breaker is recommended.

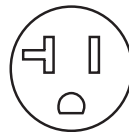

5-20R
receptacle

It is your responsibility:

- To contact a qualified electrical installer.
- To be sure that the electrical connection is adequate and in conformance with the National Electrical Code, ANSI/NFPA 70 – latest edition or the Canadian Electrical Code, C22.1 – latest edition and all local codes and ordinances.

A copy of the above code standards can be obtained from: National Fire Protection Association, One Batterymarch Park, Quincy, MA 02269 or Canadian Standards Association, 178 Rexdale Blvd., Toronto, ON M9W 1R3 CANADA.

- Do not use an extension cord.

Electrical Requirements, 240V Electric Models – Canada

⚠ WARNING



Electrical Shock Hazard

Plug into a grounded 4 prong outlet.

Failure to do so can result in death or electrical shock.

It is your responsibility:

- To contact a qualified electrical installer.
- To be sure that the electrical connection is adequate and in conformance with Canadian Electrical Code, C22.1 – latest edition and all local codes. A copy of above codes standard may be obtained from: Canadian Standards Association, 178 Rexdale Blvd., Toronto, ON M9W 1R3 CANADA.
- To supply the required 4-wire, single-phase, 120/240 volt, 60 Hz, AC only electrical supply on a separate 30 amp circuit, fused on both sides of the line. A time-delay fuse or circuit breaker is recommended. Connect to an individual branch circuit.
- This dryer is equipped with a UL Listed and/or CSA International Certified Power Cord intended to be plugged into a standard 14-30R wall receptacle. The cord is 5 ft. (1.52 m) long. Be sure wall receptacle is within reach of dryer's final location.



4-wire receptacle
(14-30R)

If using a replacement power supply cord, it is recommended that you use Power Supply Cord Replacement Part Number 9831317.

For further information, please reference service numbers located in "Assistance or Service" section of your Use and Care Guide.

GROUNDING INSTRUCTIONS

- For a grounded, cord-connected washer/dryer: This washer/dryer must be grounded. In the event of malfunction or breakdown, grounding will reduce the risk of electric shock by providing a path of least resistance for electric current. This washer/dryer is equipped with a cord having an equipment-grounding conductor and a grounding plug. The plug must be plugged into an appropriate outlet that is properly installed and grounded in accordance with all local codes and ordinances.

WARNING: Improper connection of the equipment-grounding conductor can result in a risk of electric shock. Check with a qualified electrician or service representative or personnel if you are in doubt as to whether the washer/dryer is properly grounded. Do not modify the plug provided with the washer/dryer: if it will not fit the outlet, have a proper outlet installed by a qualified electrician.

SAVE THESE INSTRUCTIONS

Electrical Requirements, Gas Models (27" [69 cm] Models Only)

WARNING



Electrical Shock Hazard

Plug into a grounded 3 prong outlet.

Do not remove ground prong.

Do not use an adapter.

Do not use an extension cord.

Failure to follow these instructions can result in death, fire, or electrical shock.

- This washer/dryer is equipped with a power supply cord having a 3-prong grounding plug.
- To minimize possible shock hazard, the cord must be plugged into a mating, 3 prong, grounding-type outlet, grounded in accordance with local codes and ordinances. If a mating outlet is not available, it is the personal responsibility and obligation of the customer to have the properly grounded outlet installed by a qualified electrician.
- If codes permit and a separate ground wire is used, it is recommended that a qualified electrician determine that the ground path is adequate.
- Do not ground to a gas pipe.
- Check with a qualified electrician if you are not sure the washer/dryer is properly grounded.
- Do not have a fuse in the neutral or ground circuit.
- 120 volt, 60 Hz, AC only, 15 or 20 amp fused electrical supply is required. A time-delay fuse or circuit breaker is recommended. It is also recommended that a separate circuit serving only this washer/dryer be provided.

GROUNDING INSTRUCTIONS

- For a grounded, cord-connected washer/dryer: This washer/dryer must be grounded. In the event of malfunction or breakdown, grounding will reduce the risk of electric shock by providing a path of least resistance for electric current. This washer/dryer is equipped with a cord having an equipment-grounding conductor and a grounding plug. The plug must be plugged into an appropriate outlet that is properly installed and grounded in accordance with all local codes and ordinances.

WARNING: Improper connection of the equipment-grounding conductor can result in a risk of electric shock. Check with a qualified electrician or service representative or personnel if you are in doubt as to whether the washer/dryer is properly grounded. Do not modify the plug provided with the washer/dryer: if it will not fit the outlet, have a proper outlet installed by a qualified electrician.

SAVE THESE INSTRUCTIONS

Gas Supply Requirements, Gas Models (27" [69 cm] Models Only)

WARNING



Explosion Hazard

Use a new CSA International approved gas supply line.

Install a shut-off valve.

Securely tighten all gas connections.

If connected to propane, have a qualified person make sure gas pressure does not exceed 13" (330 mm) water column.

Examples of a qualified person include:

**licensed heating personnel,
authorized gas company personnel, and
authorized service personnel.**

Failure to do so can result in death, explosion, or fire.

GAS TYPE

Natural Gas:

This washer/dryer is equipped for use with natural gas. It is certified by UL for use with propane gas with appropriate conversion.

- Your washer/dryer must have the correct burner for the type of gas in your home. Burner information is located on the rating plate in the door well of your dryer. If this information does not agree with the type of gas available, contact your dealer or call the phone numbers referenced in the "Assistance or Service" section of your Use and Care Guide.

Propane Gas Conversion:

IMPORTANT: Conversion must be made by a qualified technician.

No attempt shall be made to convert the appliance from the gas specified on the model/serial rating plate for use with a different gas without consulting your gas company.

GAS SUPPLY LINE

- Must include 1/8" NPT minimum plugged tapping accessible for test gauge connection, immediately upstream of the gas connection to the washer/dryer. See illustration below.
- 1/2" IPS pipe is recommended.
- Must include shut-off valve:

In the U.S.A.:

An individual manual shut-off valve must be installed within six (6) ft. (1.8 m) of the washer/dryer in accordance with the National Fuel Gas Code, ANSI Z223.1. The location should be easy to reach for opening and closing.

In Canada:

An individual manual shut-off valve must be installed in accordance with the B149.1, Natural Gas and Propane Installation Code. It is recommended that an individual manual shut-off valve be installed within six (6) ft. (1.8 m) of the washer/dryer. The location should be easy to reach for opening and closing.

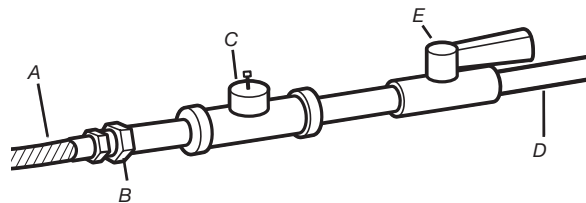

- A. 3/8" flexible gas connector
- B. 1/2" NPT adapter
- C. 1/8" NPT minimum plugged tapping
- D. 1/2" NPT gas supply line
- E. Gas shut-off valve

This washer/dryer is equipped with its own permanent, flexible gas connector, design-certified by CSA International, for connecting the washer/dryer to the gas supply line.

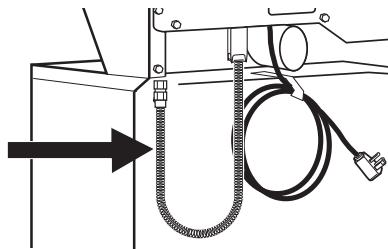

Flexible gas connector

DRYER GAS CONNECTION

Option 1

Rigid gas supply line:

- Connect your washer/dryer to the rigid gas supply line using the 1/2" NPT adapter between the gas supply line and the flexible gas connector on the washer/dryer.

Option 2

Approved aluminum or copper tubing:

- 3/8" approved aluminum or copper tubing is acceptable for lengths under 20 ft. (6.1 m) if local codes and gas supplier permit.
- If you are using natural gas, do not use copper tubing.
- Lengths over 20 ft. (6.1 m) should use larger tubing and a different size adapter fitting.
- If your washer/dryer has been converted to use propane gas, 3/8" propane compatible copper tubing can be used. If the total length of the supply line is more than 20 ft. (6.1 m), use larger pipe.

NOTE: Pipe-joint compounds that resist the action of propane gas must be used. Do not use TEFLON[†] tape.

[†]TEFLON is a registered trademark of Chemours.

GAS SUPPLY CONNECTION REQUIREMENTS

- Use the 1/2" NPT adapter between the gas supply line and the flexible gas connector on the washer/dryer.
- Use only pipe-joint compound. Do not use TEFLON[®] tape.

BURNER INPUT REQUIREMENTS

Elevations up to 10,000 ft (3,048 meters):

- The design of this washer/dryer is certified by CSA International for use at altitudes up to 10,000 ft (3,048 m) above sea level at the Btu rating indicated on the model/serial number plate. Burner input adjustments are not required when the washer/dryer is operated up to this elevation.

Elevations above 10,000 ft (3,048 meters):

- When installed above 10,000 ft. (3,048 m), a 4% reduction of the burner Btu rating shown on the model/serial number plate is required for each 1,000 ft. (305 m) increase in elevation.

Gas supply pressure testing

- The washer/dryer must be disconnected from the gas supply piping system during pressure testing at pressures greater than 1/2 psi.

Remove Foam Packing (24" [61 cm] models)

1. Pull foam packing ring out of washer

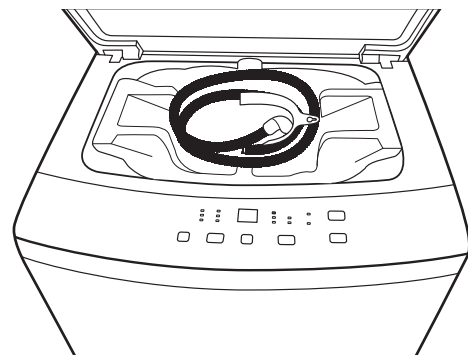

Open the washer lid. The latch under the dryer will keep the lid open. Pull the foam packing ring and drain hose out of the washer.

NOTE: Keep the foam ring and use it when transporting your washer/dryer. This packing material is used to keep the washer tub stable during transport.

Electrical Connection, 27" (69 cm) Electric Models (U.S.A. Only)

Power Supply Cord

WARNING



Fire Hazard

- Use a new UL listed 30 amp power supply cord.
- Use a UL listed strain relief.
- Disconnect power before making electrical connections.
- Connect neutral wire (white or center wire) to center terminal.
- Ground wire (green or bare wire) must be connected to green ground connector.
- Connect remaining 2 supply wires to remaining 2 terminals (gold).
- Securely tighten all electrical connections.
- Failure to do so can result in death, fire, or electrical shock.

Direct Wire

WARNING



Fire Hazard

- Use 10 gauge copper wire.
- Use a UL listed strain relief.
- Disconnect power before making electrical connections.
- Connect neutral wire (white or center wire) to center terminal.
- Ground wire (green or bare wire) must be connected to green ground connector.
- Connect remaining 2 supply wires to remaining 2 terminals (gold).
- Securely tighten all electrical connections.
- Failure to do so can result in death, fire, or electrical shock.

Electrical Connection Options

1. Choose electrical connection type



Power supply cord 4-wire receptacle (NEMA Type 14-30R): Go to "4-Wire Power Supply Cord Connection." Then, go to "Venting Requirements."



Power supply cord 3-wire receptacle (NEMA Type 10-30R): Go to "3-Wire Power Supply Cord Connection." Then go to "Venting Requirements."



4-wire direct connection: Go to "4-Wire Direct Wire Connection." Then go to "Venting Requirements."



3-wire direct connection: Go to "3-Wire Direct Wire Connection." Then go to "Venting Requirements."

NOTE: If local codes do not permit connection of a cabinet-ground conductor to neutral wire, go to "Optional 3-Wire Connection." This connection may be used with either a power supply cord or a direct wire connection.

2. Remove terminal block cover

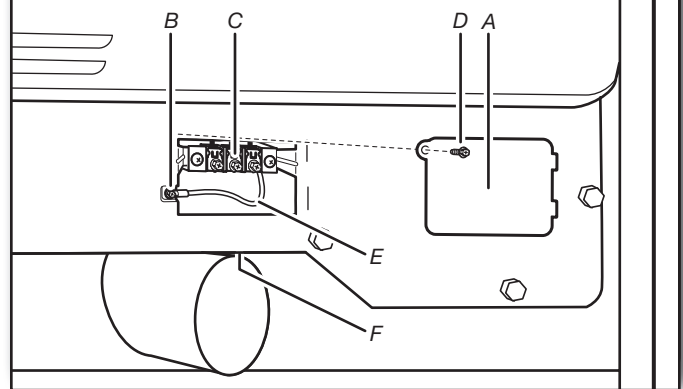

Before you start, disconnect power. Remove hold-down screw (D) and terminal block cover (A).

- A. Terminal block cover
- B. External ground conductor screw
- C. Center terminal block screw
- D. Hold-down screw
- E. Neutral ground wire
- F. Hole below terminal block cover

Power Supply Cord Connection

Power Supply Cord Strain Relief

1. Attach power supply cord strain relief

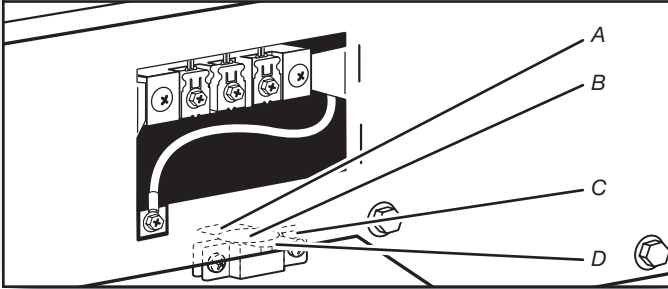

Remove the screws from a 3/4" (19 mm) UL Listed strain relief. Put the tabs of the two clamp sections (C) into the hole below the terminal block opening (B) so that one tab is pointing up (A) and the other is pointing down (D), and hold in place. Tighten strain relief screws just enough to hold the two clamp sections (C) together.

2. Attach power supply cord to strain relief

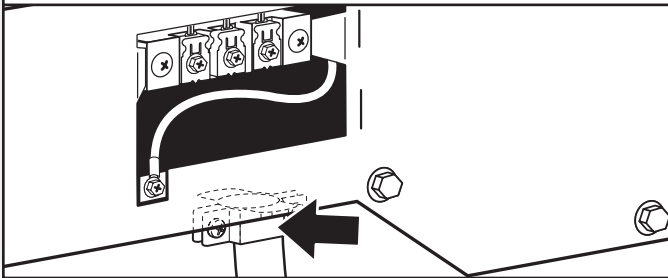

Put power supply cord through the strain relief. Be sure that the wire insulation on the power supply cord is inside the strain relief. The strain relief should have a tight fit with the dryer cabinet and be in a horizontal position. Do not further tighten strain relief screws at this point.

If your outlet looks like this:



Power supply cord 4-wire receptacle (NEMA Type 14-30R):
Go to "4-Wire Power Supply Cord Connection" on this page.



Power supply cord 3-wire receptacle (NEMA Type 10-30R):
Go to "3-Wire Power Supply Cord Connection" on page 17.

4-Wire Power Supply Cord Connection

IMPORTANT: A 4-wire connection is required for mobile homes and where local codes do not permit the use of 3-wire connections.

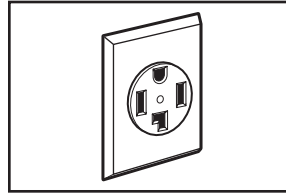

4-wire receptacle (NEMA type 14-30R)

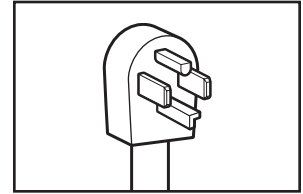

4 prong plug

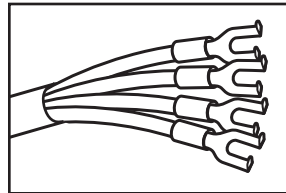

Spade terminals with upturned ends

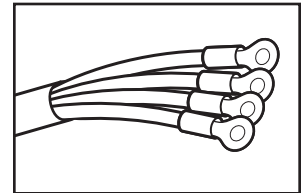

Ring terminals

1. Prepare to connect neutral ground wire and neutral wire

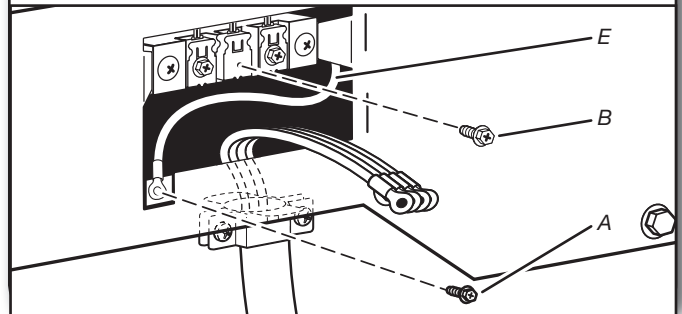

Remove center terminal block screw (B). Remove neutral ground wire (E) from external ground conductor screw (A).

2. Connect neutral ground wire and neutral wire

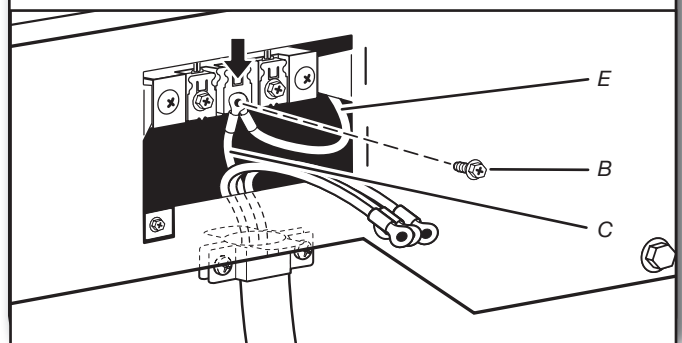

Connect neutral ground wire (E) and neutral wire (white or center) (C) of power supply cord under center terminal block screw (B). Tighten screw.

3. Connect ground wire

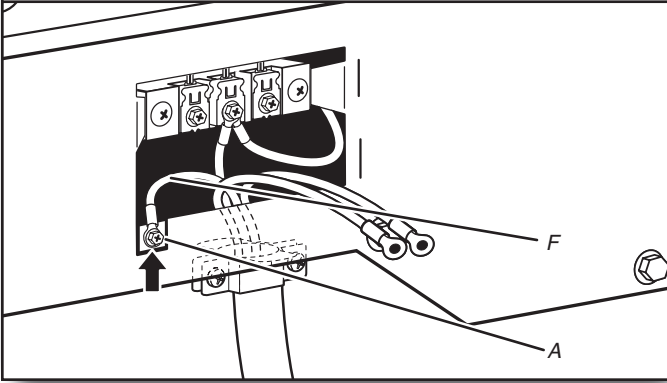

Connect ground wire (F) (green or bare) of power supply cord to external ground conductor screw (A). Tighten screw.

4. Connect remaining wires

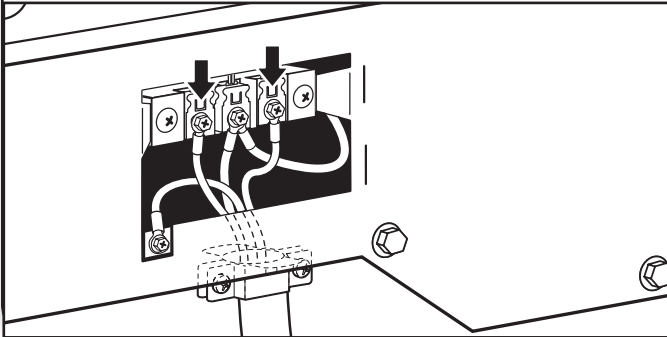

Connect remaining wires to outer terminal block screws. Tighten screws. Finally, reinsert tab of terminal block cover into slot of dryer rear panel. Secure cover with hold-down screw. Now, go to "Venting Requirements."

3-Wire Power Supply Cord Connection

IMPORTANT: Use where local codes permit connecting cabinet-ground conductor to neutral wire.

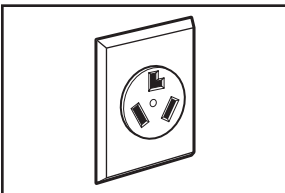

3-wire receptacle
(NEMA type 10-30R)

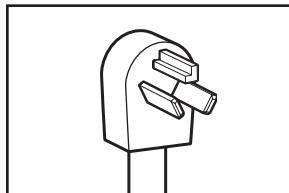

3 prong plug

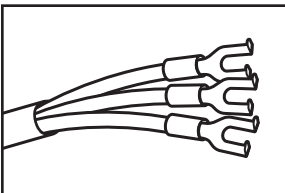

Spade terminals
with upturned ends

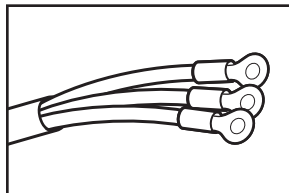

Ring terminals

1. Remove center screw

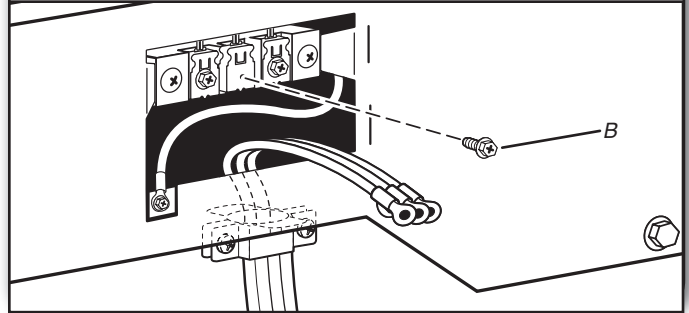

Remove center terminal block screw (B).

2. Connect neutral wire

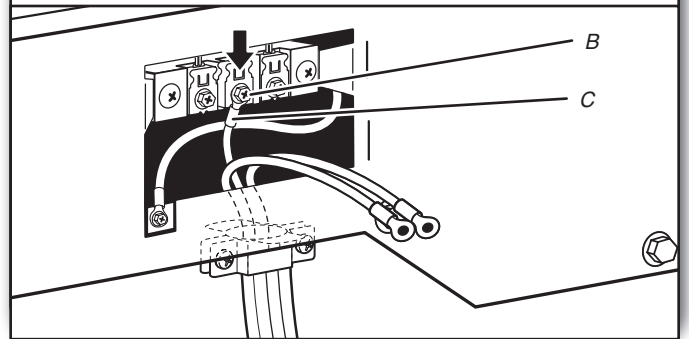

Connect neutral wire (white or center) (C) of power supply cord to center terminal block screw (B). Tighten screw.

3. Connect remaining wires

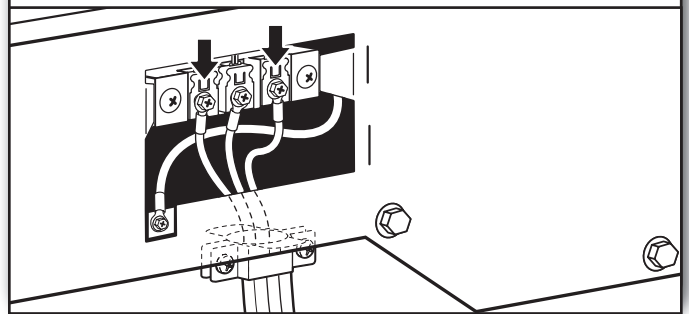

Connect remaining wires to outer terminal block screws. Tighten screws. Finally, reinsert tab of terminal block cover into slot of dryer rear panel. Secure cover with hold-down screw. Now, go to "Venting Requirements."

Direct Wire Connection

Direct Wire Strain Relief

1. Attach direct wire strain relief

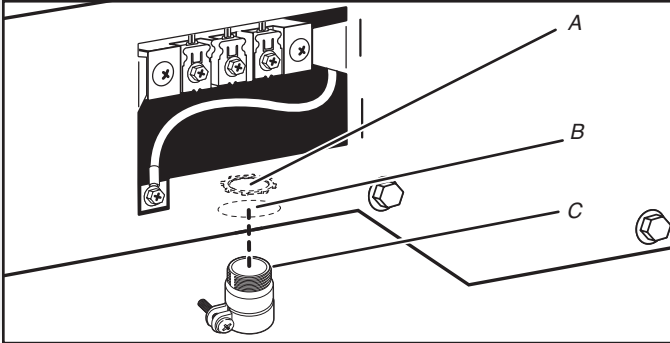

Unscrew the removable conduit connector (A) and any screws from a 3/4" (19 mm) UL Listed strain relief. Put the threaded section of the strain relief (C) through the hole below the terminal block opening (B). Reaching inside the terminal block opening, screw the removable conduit connector (A) onto the strain relief threads.

2. Attach direct wire cable to strain relief

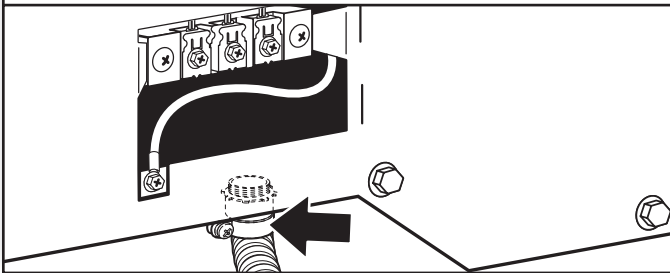

Put direct wire cable through the strain relief. The strain relief should have a tight fit with the dryer cabinet and be in a horizontal position. Tighten strain relief screw against the direct wire cable.

If your wiring looks like this:



4-wire direct wire connection:
Go to "4-Wire Direct Wire Connection"
on this page.



3-wire direct wire connection:
Go to "3-Wire Direct Wire Connection"
on page 19.

4-Wire Direct Wire Connection

IMPORTANT: A 4-wire connection is required for mobile homes and where local codes do not permit 3-wire connections.

1. Prepare your 4-wire cable for direct connection

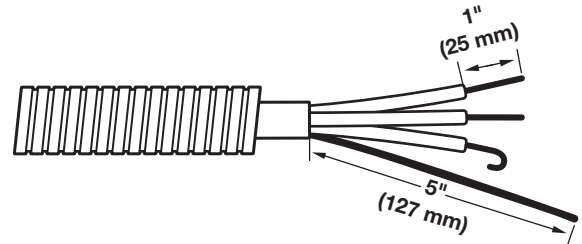

Direct wire cable must have 5 ft. (1.52 m) of extra length so washer/dryer may be moved if needed.

Strip 5" (127 mm) of outer covering from end of cable, leaving bare ground wire at 5" (127 mm). Cut 1½" (38 mm) from remaining 3 wires. Strip insulation back 1" (25 mm). Shape ends of wires into hooks.

2. Prepare to connect neutral ground wire and neutral wire

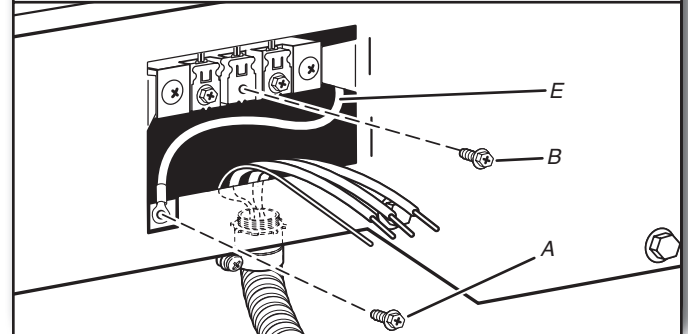

Remove center terminal block screw (B). Remove neutral ground wire (E) from external ground conductor screw (A).

3. Connect neutral ground wire and neutral wire

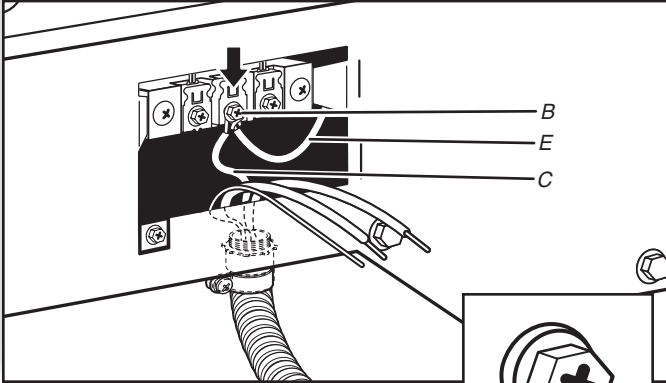

Connect neutral ground wire (E) and place hooked end (hook facing right) of neutral wire (white or center wire) (C) of direct wire cable under center screw of terminal block (B). Squeeze hooked ends together and tighten screw.

4. Connect ground wire

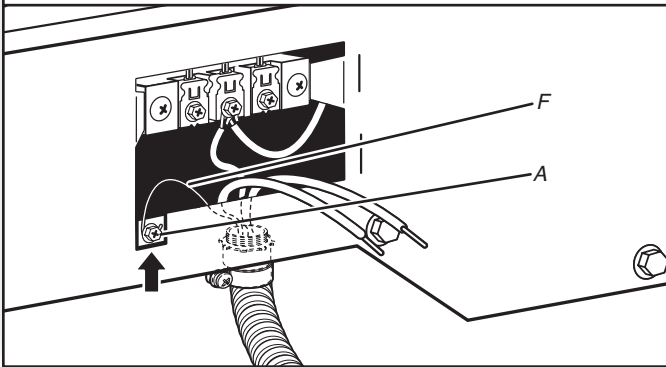

Connect ground wire (green or bare) (F) of direct wire cable to external ground conductor screw (A). Tighten screw.

5. Connect remaining wires

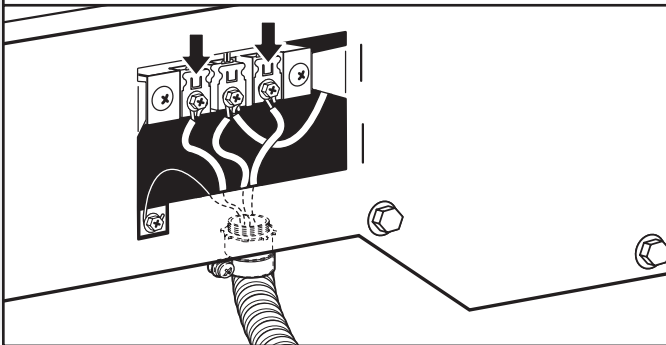

Place hooked ends of remaining direct wire cable wires under outer terminal block screws (hooks facing right). Squeeze hooked ends together and tighten screws. Finally, reinsert tab of terminal block cover into slot of dryer rear panel. Secure cover with hold-down screw. Now, go to "Venting Requirements."

3-Wire Direct Wire Connection

IMPORTANT: Use where local codes permit connecting cabinet-ground conductor to neutral wire.

1. Prepare your 3-wire cable for direct connection

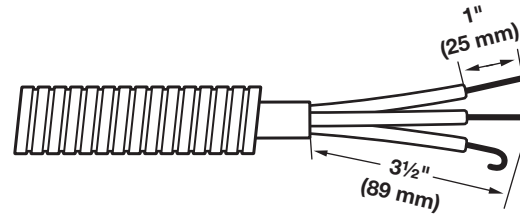

Direct wire cable must have 5 ft. (1.52 m) of extra length so washer/dryer may be moved if needed.

Strip 3 1/2" (89 mm) of outer covering from end of cable. Strip insulation back 1" (25 mm). If using 3-wire cable with ground wire, cut bare wire even with outer covering. Shape wire ends into hooks.

2. Remove center screw

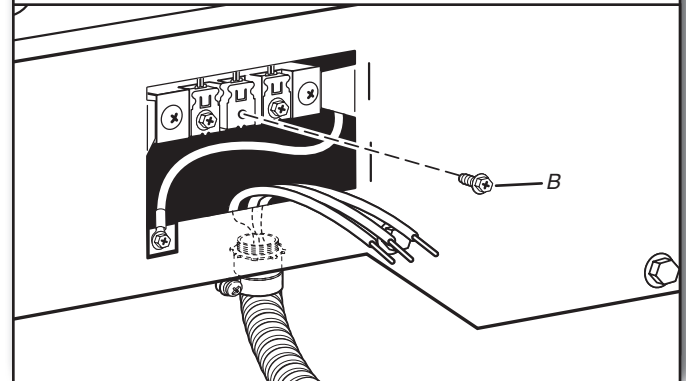

Remove center terminal block screw (B).

3. Connect neutral wire

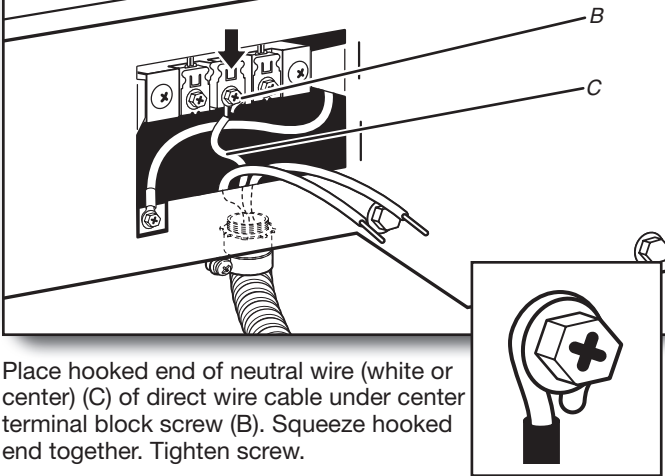

Place hooked end of neutral wire (white or center) (C) of direct wire cable under center terminal block screw (B). Squeeze hooked end together. Tighten screw.

2. Connect neutral ground wire and neutral wire

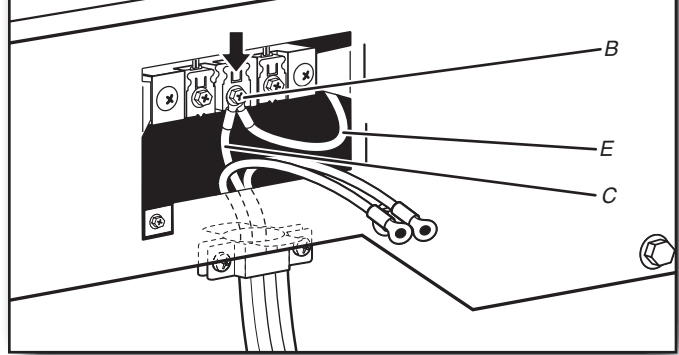

Connect neutral ground wire (E) and neutral wire (white or center wire) (C) of power supply cord or cable under center terminal block screw (B). Tighten screw.

4. Connect remaining wires

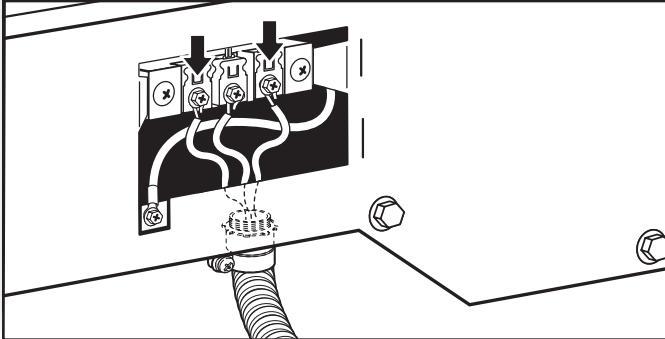

Place hooked ends of remaining direct wire cable wires under outer terminal block screws (hooks facing right). Squeeze hooked ends together and tighten screws. Finally, reinsert tab of terminal block cover into slot of dryer rear panel. Secure cover with hold-down screw. Now, go to "Venting Requirements."

3. Connect remaining wires

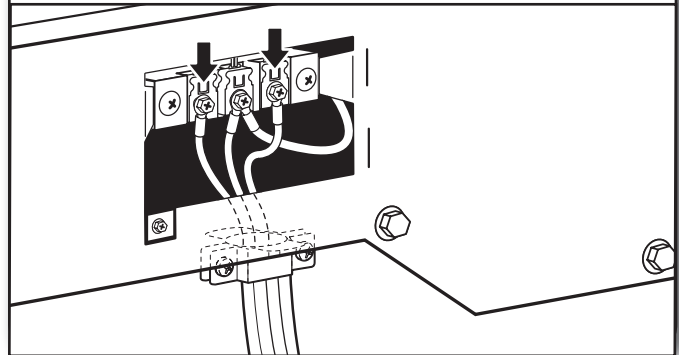

Place remaining wires under outer terminal block screws (hooks facing right). Tighten screws.

Optional 3-Wire Connection

IMPORTANT: You must verify with a qualified electrician that this grounding method is acceptable before connecting.

1. Prepare to connect neutral ground wire and neutral wire

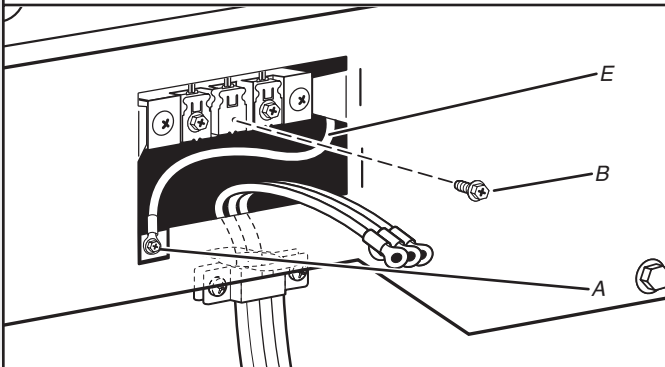

Remove center terminal block screw (B). Remove neutral ground wire (E) from external ground conductor screw (A).

4. Connect external ground wire

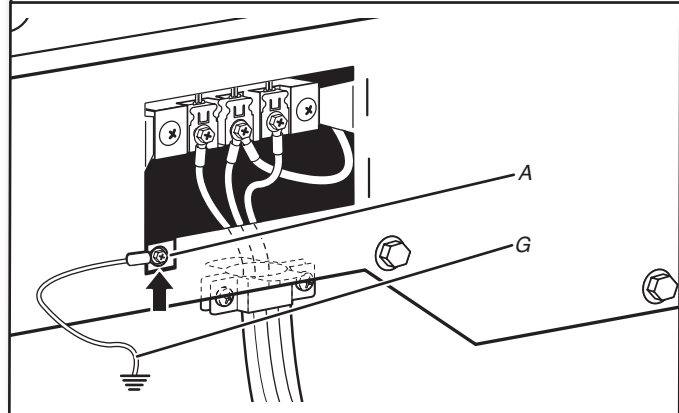

Connect a separate copper ground wire (G) from the external ground conductor screw (A) to an adequate ground. Finally, reinsert tab of terminal block cover into slot of dryer rear panel. Secure cover with hold-down screw. Now, go to "Venting Requirements."

Electrical Connection, 24" (61 cm) 240V Electric Models (U.S.A. Only)

Power Supply Cord

WARNING



Fire Hazard

Use a new UL listed 30 amp power supply cord.

Use a UL listed strain relief.

Disconnect power before making electrical connections.

Connect neutral wire (white or center wire) to center terminal.

Ground wire (green or bare wire) must be connected to green ground connector.

Connect remaining 2 supply wires to remaining 2 terminals (gold).

Securely tighten all electrical connections.

Failure to do so can result in death, fire, or electrical shock.

Electrical Connection Options

1. Choose electrical connection type



Power supply cord 4-wire receptacle (NEMA Type 14-30R): Go to "4-Wire Power Supply Cord Connection." Then, go to "Venting Requirements."



Power supply cord 3-wire receptacle (NEMA Type 10-30R): Go to "3-Wire Power Supply Cord Connection." Then go to "Venting Requirements."

NOTE: If local codes do not permit connection of a cabinet-ground conductor to neutral wire, go to "Optional 3-Wire Connection."

2. Remove terminal block cover

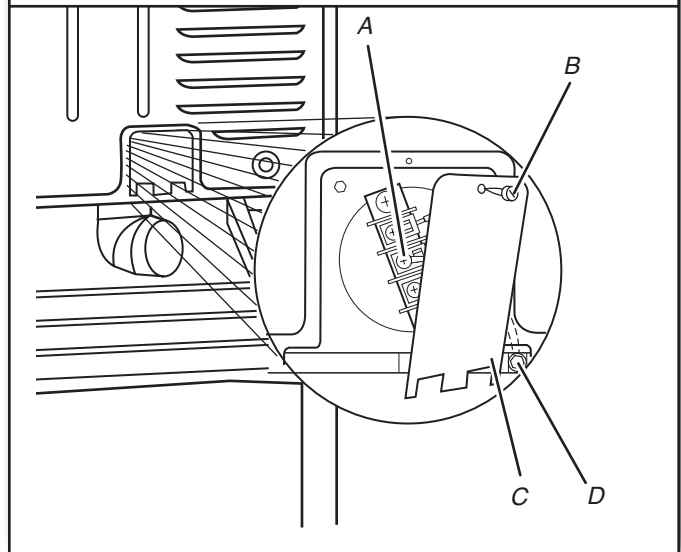

Before you start, disconnect power. Remove hold-down screw (B) and terminal block cover (C).

- A. Center terminal block screw
- B. Hold-down screw
- C. Terminal block cover
- D. External ground conductor screw

Power Supply Cord Connection

Power Supply Cord Strain Relief

1. Attach power supply cord strain relief

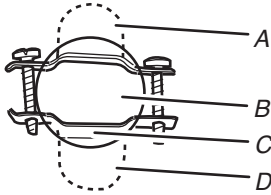

Remove the screws from a 3/4" (19 mm) UL Listed strain relief. Put the tabs of the two clamp sections (C) into the hole below the terminal block opening (B) so that one tab is pointing up (A) and the other is pointing down (D), and hold in place. Tighten strain relief screws just enough to hold the two clamp sections (C) together.

- A. Strain relief tab pointing up
- B. Hole below terminal block opening
- C. Clamp section
- D. Strain relief tab pointing down

2. Attach power supply cord to strain relief

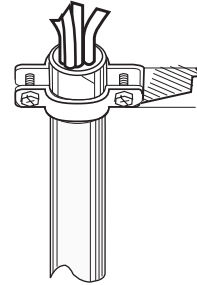

Put power supply cord through the strain relief. Be sure that the wire insulation on the power supply cord is inside the strain relief. The strain relief should have a tight fit with the dryer cabinet and be in a horizontal position. Do not further tighten strain relief screws at this point.

4-Wire Power Supply Cord Connection

IMPORTANT: A 4-wire connection is required for mobile homes and where local codes do not permit the use of 3-wire connections.

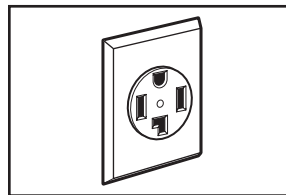

4-wire receptacle
(NEMA type 14-30R)

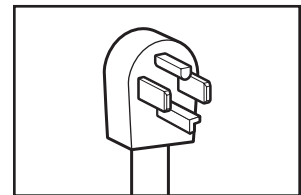

4 prong plug

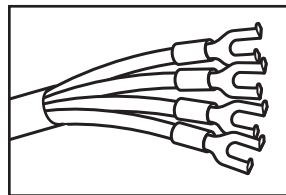

Spade terminals
with upturned ends

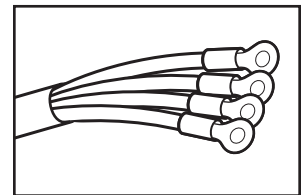

Ring terminals

1. Connect neutral ground wire and neutral wire

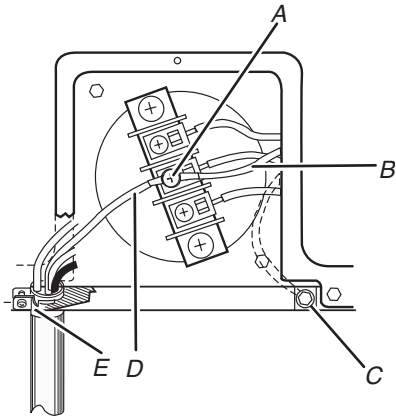

Remove center terminal block screw. Remove neutral ground wire from external ground conductor screw. Connect neutral ground wire and the neutral wire (white or center wire) of power supply cord under center terminal block screw. Tighten screw.

- A. Center terminal block screw
- B. Neutral ground wire
- C. External ground conductor screw – Dotted line shows position of NEUTRAL ground wire before being moved to center terminal block screw.
- D. Neutral wire (white or center wire)
- E. 3/4" (19 mm) UL Listed strain relief

2. Connect ground wire

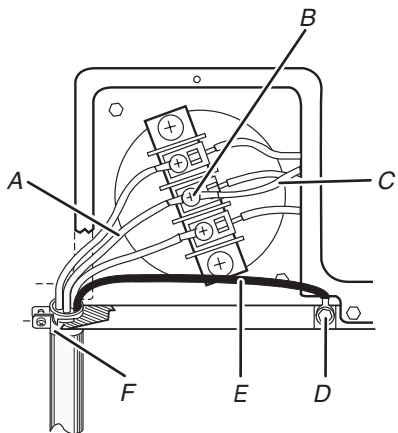

Connect ground wire (green or bare) of power supply cord to external ground conductor screw. Tighten screw.

- A. Neutral wire (white or center wire)
- B. Center terminal block screw
- C. Neutral ground wire
- D. External ground conductor screw
- E. Ground wire (green or bare) of power supply cord
- F. 3/4" (19 mm) UL Listed strain relief

Connect the other wires to outer terminal block screws. Tighten screws. Tighten strain relief screws. Insert tab of terminal block cover into slot of dryer rear panel. Secure cover with hold-down screw. Now go to "Venting Requirements."

3-Wire Power Supply Cord Connection

IMPORTANT: Use where local codes permit connecting cabinet-ground conductor to neutral wire.

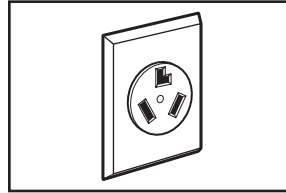

3-wire receptacle
(NEMA type 10-30R)

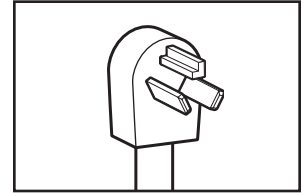

3 prong plug

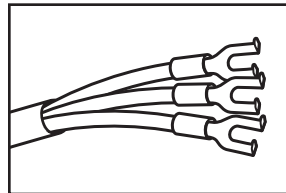

Spade terminals
with upturned ends

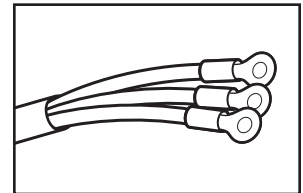

Ring terminals

1. Connect neutral wire

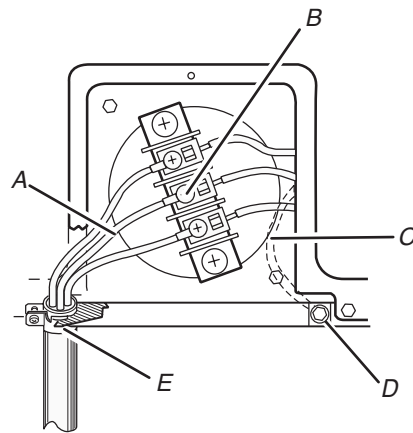

Loosen or remove center terminal block screw. Connect neutral wire (white or center wire) of power supply cord to the center terminal screw of the terminal block. Tighten screw.

- A. Neutral wire (white or center wire)
- B. Center terminal block screw
- C. Neutral ground wire
- D. External ground conductor screw
- E. 3/4" (19 mm) UL Listed strain relief

Connect the other wires to outer terminal block screws. Tighten screws. Tighten strain relief screws. Insert tab of terminal block cover into slot of dryer rear panel. Secure cover with hold-down screw. Now go to "Venting Requirements."

Optional 3-Wire Connection

Use for power supply cord where local codes do not permit connecting cabinet-ground conductor to neutral wire.

1. Connect neutral ground wire and neutral wire

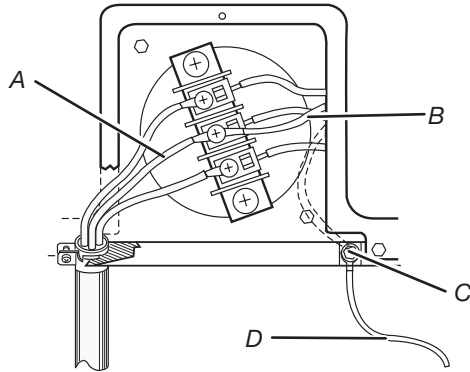

Remove center terminal block screw. Remove neutral ground wire from external ground conductor screw. Connect neutral ground wire and the neutral wire (white or center wire) of power supply cord under center terminal block screw. Tighten screw.

- A. Neutral wire (white or center wire)
- B. Neutral ground wire
- C. External ground conductor screw – Dotted line shows position of NEUTRAL ground wire before being moved to center terminal block screw.
- D. Grounding path determined by a qualified electrician

2. Connect remaining wires and connect separate ground wire

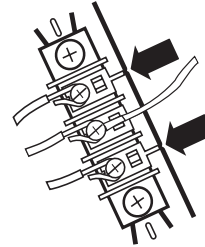

Connect the other wires to outer terminal block screws. Tighten screws. Tighten strain relief screws. Connect a separate copper ground wire from the external ground conductor screw to an adequate ground. Insert tab of terminal block cover into slot of dryer rear panel. Secure cover with hold-down screw. Now go to "Venting Requirements."

Venting

Venting Requirements

⚠ WARNING



Fire Hazard

Use a heavy metal vent.

Do not use a plastic vent.

Do not use a metal foil vent.

Failure to follow these instructions can result in death or fire.

WARNING: To reduce the risk of fire, this dryer MUST BE EXHAUSTED OUTDOORS.

IMPORTANT: Observe all governing codes and ordinances. Dryer exhaust must not be connected into any gas vent, chimney, wall, ceiling, attic, crawlspace, or a concealed space of a building. Only rigid or flexible metal vent shall be used for exhausting.

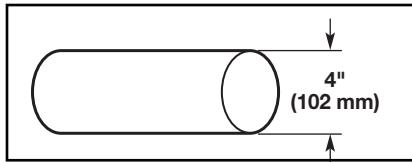

- Only a 4" (102 mm) heavy metal exhaust vent and clamps may be used.
- Do not use plastic or metal foil vent.

Rigid metal vent:

- Recommended for best drying performance and to avoid crushing and kinking.

Flexible metal vent: (Acceptable only if accessible to clean)

- Must be fully extended and supported in final dryer location.
- Remove excess to avoid sagging and kinking that may result in reduced airflow and poor performance.
- Do not install in enclosed walls, ceilings, or floors.
- The total length should not exceed 7¾ ft. (2.4 m).

NOTE: If using an existing vent system, clean lint from entire length of the system and make sure exhaust hood is not plugged with lint. Replace plastic or metal foil vents with rigid metal or flexible metal vents. Review "Vent System Chart" and, if necessary, modify existing vent system to achieve best drying performance.

Exhaust hoods:

- Must be at least 12" (305 mm) from ground or any object that may obstruct exhaust (such as flowers, rocks, bushes, or snow).

Recommended Styles:

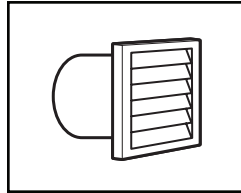

Louvered hood

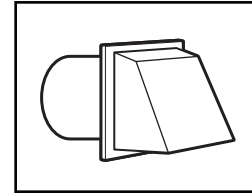

Box hood

Acceptable Style:

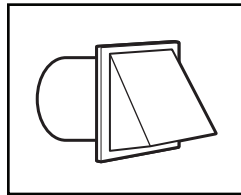

Angled hood

Elbows:

- 45° elbows provide better airflow than 90° elbows.

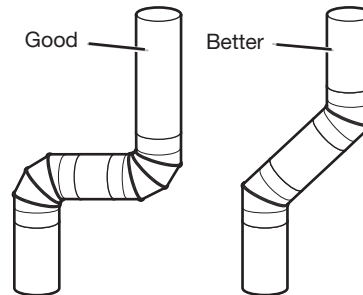

Clamps:

- Use clamps to seal all joints.
- Exhaust vent must not be connected or secured with screws or other fastening devices that extend into interior of duct and catch lint. Do not use duct tape.

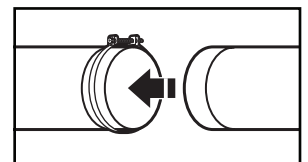
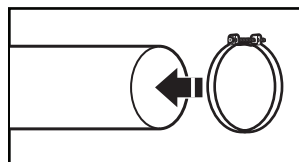

Improper venting can cause moisture and lint to collect indoors, which may result in:

- Moisture damage to woodwork, furniture, paint, wallpaper, carpets, etc.
- Housecleaning problems and health problems.

See "Venting Kits" for more information.

Plan Vent System

Recommended exhaust installations

Typical installations vent the washer/dryer from the rear. Other installations are possible.

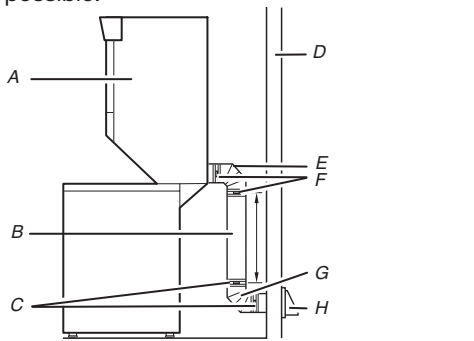

- | | |
|---------------------------------------|-----------------|
| A. Dryer | E. Elbow |
| B. Rigid metal or flexible metal vent | F. Clamps |
| C. Clamps | G. Elbow |
| D. Wall | H. Exhaust hood |

Optional exhaust installations:

24" (61 cm) washer/dryer models can be converted to exhaust out the right or left side. To convert the washer/dryer, use Side Exhaust Kit Part Number 279823. If your washer/dryer was previously exhausted from the right or left side, it can be converted to rear exhaust by using standard offset connections. To cover the hole in the side, the following plug can be added: 692790 (white)

Follow the instructions in the kit to install. The kit is available from the dealer from whom you purchased your washer/dryer.

⚠ WARNING



Fire Hazard

Cover unused exhaust holes with a manufacturer's exhaust cover kit.

Contact your local dealer.

Failure to follow these instructions can result in death, fire, electrical shock, or serious injury.

Alternate installations for close clearances

Venting systems come in many varieties. Select the type best for your installation. Three close-clearance installations are shown. Refer to the manufacturer's instructions.

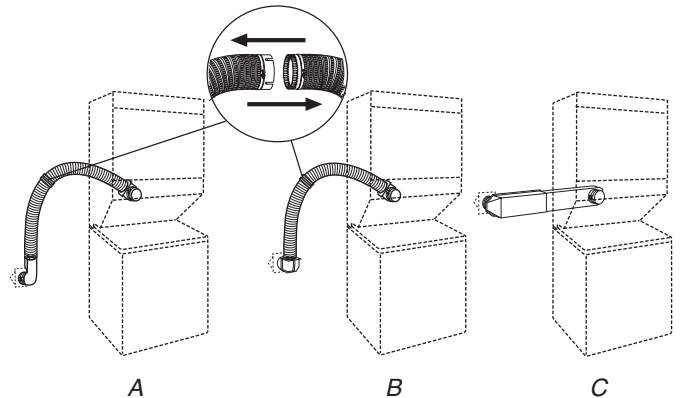

- A. Loop system with standard elbows
 B. Loop system with one offset and one standard elbow
 C. Vent system with one periscope (2" [51 mm] clearance)

Venting Kits

For more information, call **1-866-698-2538**, or visit us at www.whirlpool.com. In Canada, call **1-800-688-2002** or visit us at www.whirlpool.ca.

Special provisions for mobile home installations:

The exhaust vent must be securely fastened to a noncombustible portion of the mobile home structure and must not terminate beneath the mobile home. Terminate the exhaust vent outside.

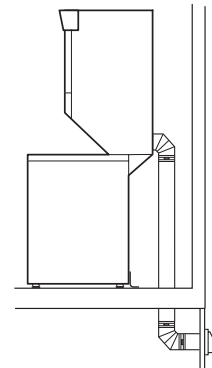

Determine vent path:

- Select route that will provide straightest and most direct path outdoors.
- Plan installation to use fewest number of elbows and turns.
- When using elbows or making turns, allow as much room as possible.
- Bend vent gradually to avoid kinking.
- Use as few 90° turns as possible.

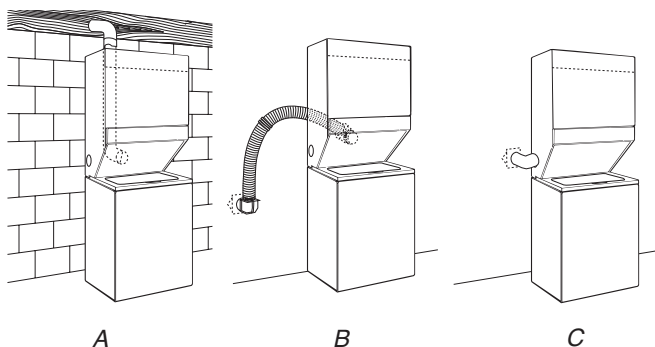

- A. Standard rear offset exhaust installation
 B. Rear exhaust for offset close-clearance connection
 C. Left- or right-side exhaust installation (24" [61 cm] models only)

Install Vent System

Determine vent length and elbows needed for best drying performance:

- Use following Vent System Chart to determine type of vent material and hood combinations acceptable to use.

NOTE: Do not use vent runs longer than those specified in Vent System Chart. Exhaust systems longer than those specified will:

- Shorten life of dryer.
- Reduce performance, resulting in longer drying times and increased energy usage.

The Vent System Chart provides venting requirements that will help achieve best drying performance.

Vent System Chart, 27" (69 cm) Models

Number of 90° turns or elbows	Type of vent	Angled hoods
0	Rigid metal	35 ft. (10.7 m)
1	Rigid metal	27 ft. (8.2 m)
2	Rigid metal	19 ft. (5.8 m)

Vent System Chart, 24" (61 cm) Models

Number of 90° turns or elbows	Type of vent	Angled hoods
0	Rigid metal	36 ft. (11.0 m)
1	Rigid metal	26 ft. (7.9 m)
2	Rigid metal	16 ft. (4.9 m)

NOTE: Side exhaust installations (24" [61 cm] models only) have a 90° turn inside the dryer. To determine maximum exhaust length, add one 90° turn to the chart.

Vent System Chart, 27" (69 cm) Long Vent Models WETLV27H and WGLV27H (U.S. Only)

Number of 90° turns or elbows	Type of vent	Angled hoods
0	Rigid metal	125 ft. (38.1 m)
1	Rigid metal	115 ft. (35.1 m)
2	Rigid metal	105 ft. (32.0 m)
3	Rigid metal	95 ft. (29.0 m)
4	Rigid metal	85 ft. (25.9 m)
5	Rigid metal	75 ft. (22.9 m)

1. Install exhaust hood

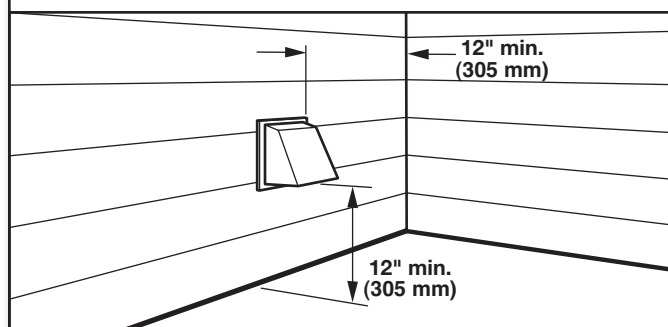

Install exhaust hood and use caulking compound to seal exterior wall opening around exhaust hood.

2. Connect vent to exhaust hood

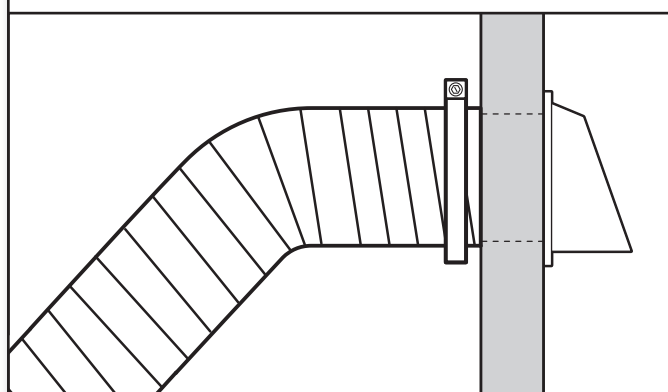

Vent must fit inside the exhaust hood. Secure vent to exhaust hood with 4" (102 mm) clamp. Run vent to dryer location using straightest path possible. Avoid 90° turns. Use clamps to seal all joints. Do not use duct tape, screws, or other fastening devices that extend into interior of vent to secure vent, because they can catch lint.

Connect Drain Hose

Proper connection of the drain hose protects your floors from damage due to water leakage. To keep the drain hose from coming off or leaking, it must be installed according to the following instructions:

IMPORTANT: To ensure proper installation, this procedure must be followed exactly.

1. Attach clamp to drain hose

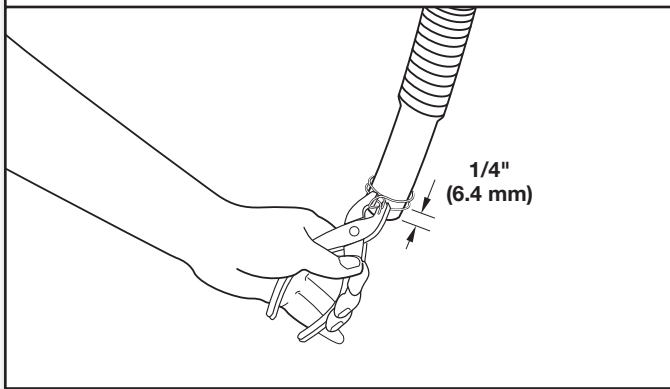

Check the drain hose to see whether it is the proper length. Wet the inside of the straight end of the drain hose with tap water.

IMPORTANT: Do not use any lubricant other than water.

Squeeze ears of the silver double-wire clamp with pliers to open. Place clamp over the straight end of the drain hose 1/4" (6.4 mm) from the end.

2. Attach drain hose to drain connector (27" [69 cm] model shown)

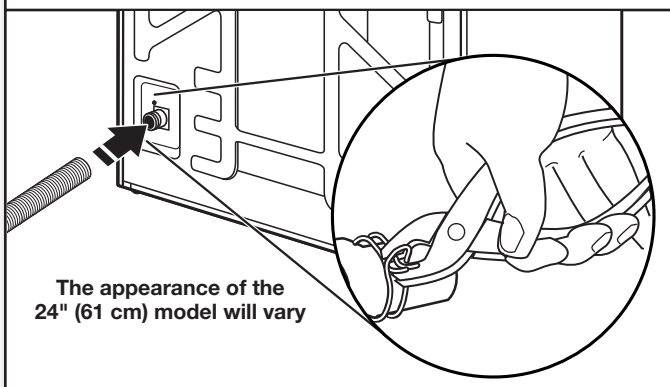

Open clamp. Twist hose back and forth while pushing onto drain connector at the lower left (27" [69 cm] models) or lower center (24" [61 cm] models) portion of the rear of the washer/dryer. Continue until hose contacts the ribbed stops on the cabinet. On 27" (69 cm) models, place clamp over the area on the hose marked "CLAMP." On 24" (61 cm) models, place clamp over the smooth area on the hose between the two ribs. Release clamp.

3. Place drain hose in standpipe

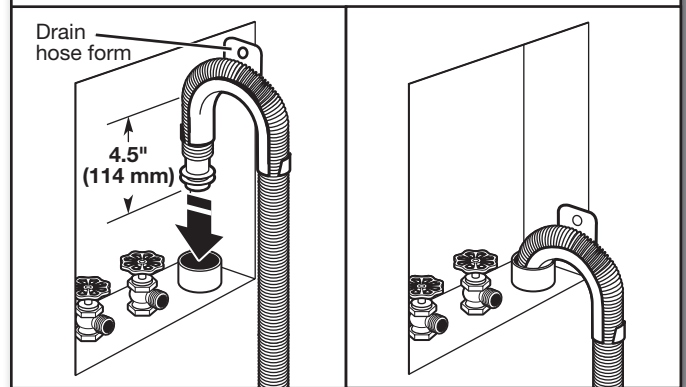

Place hose into standpipe (shown in picture) or over side of laundry tub.

IMPORTANT: 4.5" (114 mm) of drain hose should be inside standpipe; do not force excess hose into standpipe or lay on bottom of laundry tub. Drain hose form must be used.

4. Remove drain hose form (floor drain installations only)

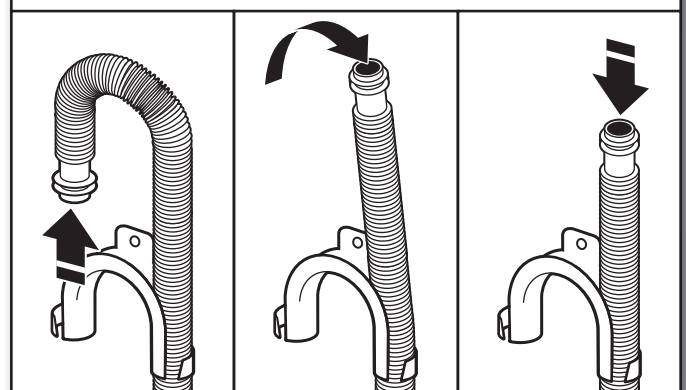

For floor drain installations, you will need to remove the drain hose form from the end of the drain hose. You may need additional parts with separate directions. See "Tools and Parts."

Connect Inlet Hoses

Washer must be connected to water faucets with new inlet hoses with flat washers (not provided). Do not use old hoses.

NOTE: Both hoses must be attached and have water flowing to inlet valves. If you are only connecting to a cold water faucet, you must use a Y-adapter (not included).

1. Insert washer into each hose

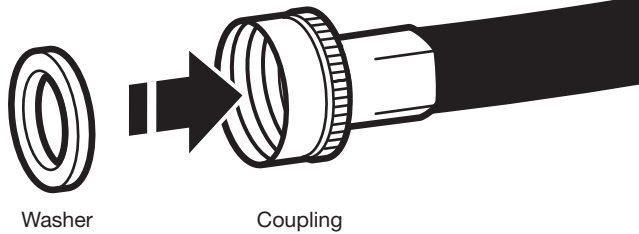

Insert a new flat washer into each end of the inlet hoses (not provided). Firmly seat the washers in the couplings.

2. Connect inlet hoses to water faucets

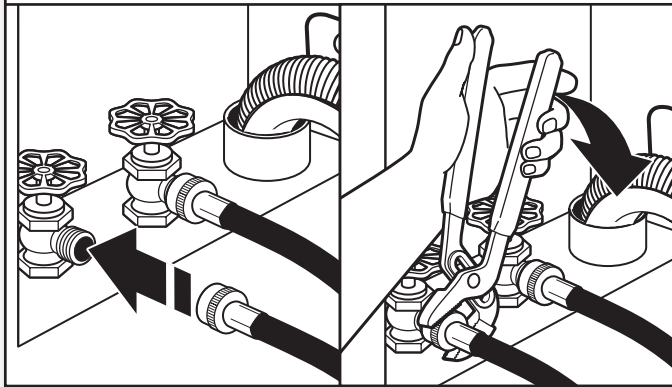

Attach hose to hot water faucet. Screw on coupling by hand until it is seated on washer. Use pliers to tighten couplings an additional two-thirds turn. Repeat this step with second hose for cold water faucet.

IMPORTANT: Do not overtighten or use tape or sealants on valve when attaching to faucets or washer. Damage can result.

HELPFUL TIP: Make note of which hose is connected to hot water to help in attaching hoses to washer correctly. In most standard configurations, hoses will cross over each other when attached correctly.

3. Clear water lines

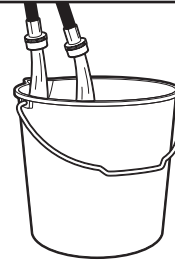

Run water for a few seconds through hoses into a laundry tub, drainpipe, or bucket to prevent clogs. Water should run until clear.

4. Connect inlet hoses to washer

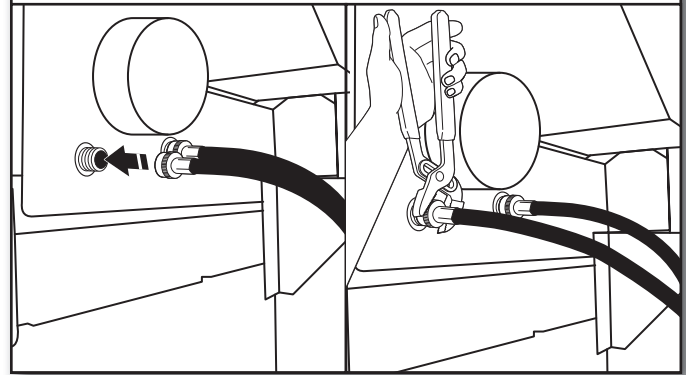

Attach hot water hose to the right-hand (red) inlet valve. Screw coupling by hand until it is snug. Use pliers to tighten couplings an additional two-thirds turn. Repeat with cold water inlet valve (left-hand [blue] inlet valve).

IMPORTANT: To reduce risk of hose failure, replace the hoses every 5 years. Record hose installation or replacement dates for future reference.

- Periodically inspect and replace hoses if bulges, kinks, cuts, wear, or leaks are found.

5. Move washer/dryer to final location

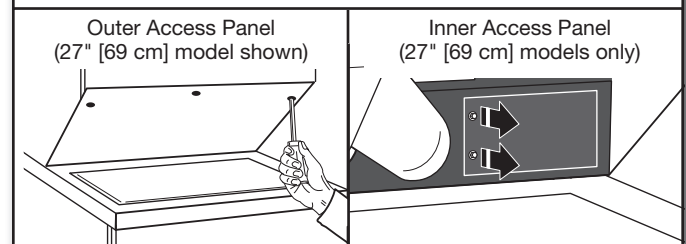

If you are working in a closet or recessed area: move the washer/dryer into its final location and remove cardboard from under washer/dryer. Remove the outer access panel by removing two (24" [61 cm] models) or three (27" [69 cm] models) Phillips-head screws and one bumper (27" [69 cm] models only), located at the top of the access panel. Remove inner access panel (27" [69 cm] models only) by removing cover and two screws. Set panels, screws, inner access panel cover, and bumper aside. Complete hookup of water hoses and vent. Replace access panels upon completion of washer/dryer installation.

Make Gas Connection (Gas 27" [69 cm] Models Only)

6. Check for leaks

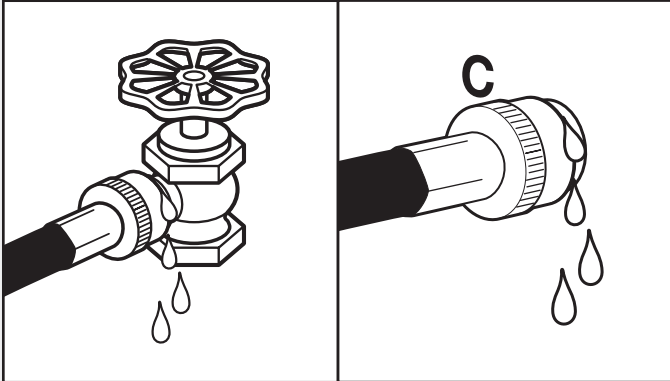

Turn on water faucets to check for leaks. A small amount of water may enter washer. It will drain later.

7. Secure drain hose

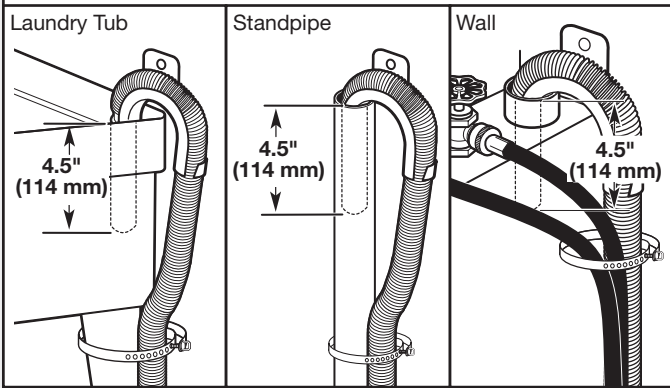

Secure drain hose to laundry tub leg, drain standpipe, or inlet hoses for wall standpipe with plastic strap included in the parts package.

It is the responsibility of the installer to install and secure the drain hose into the provided plumbing/drain in a manner that will avoid the drain hose coming out of or leaking from the plumbing/drain.

1. Preparing to connect gas supply to dryer

- A. Flared male fitting
- B. Non-flared male fitting

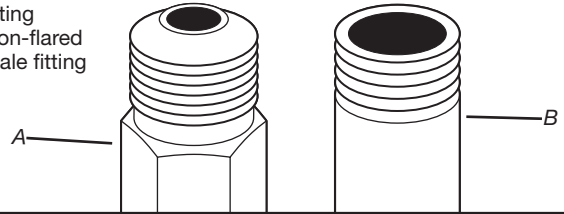

Remove red cap from flexible gas connector. Remove the 1/2" NPT adapter from the flexible gas connector (it will be necessary to use two adjustable wrenches). Use pipe-joint compound on threads of all non-flared male fittings. If flexible metal tubing is used, be sure there are no kinks.

NOTE: For propane gas connections, you must use pipe-joint compound resistant to action of propane gas. Do not use TEFLON® tape.

2. Install adapter

- A. 1/2" rigid gas supply pipe
- B. Use pipe-joint compound.
- C. 1/2" NPT adapter
- D. Do not use pipe-joint compound.
- E. Flexible gas connector

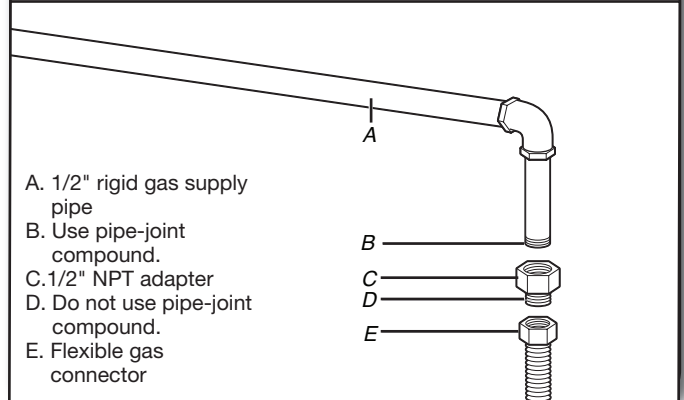

Install the adapter on the 1/2" rigid gas supply pipe using pipe-joint compound.

NOTE: For propane gas connections, you must use pipe-joint compound resistant to action of propane gas. Do not use TEFLON® tape.

3. Attach connector

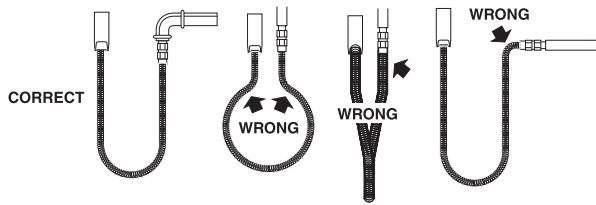

Attach the flexible gas connector to the 1/2" NPT adapter. Do not use pipe-joint compound for this connection.

There should be a natural loop in the flexible gas connector. The flexible gas connector must not be twisted, kinked, or attached with any sharp bends.

4. Open shut-off valve

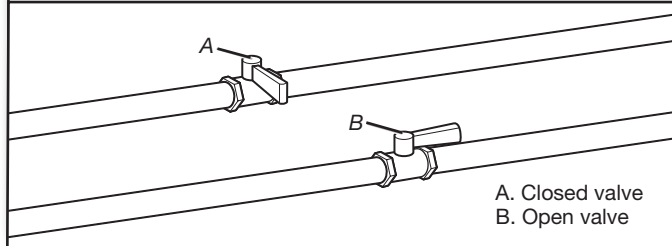

Open shut-off valve in supply line; valve is open when handle is parallel to gas pipe. Then, test all connections by brushing on an approved noncorrosive leak-detection solution. Bubbles will show a leak. Correct any leak found.

Connect Vent

1. Connect vent to exhaust outlet (27" [69 cm] model shown)

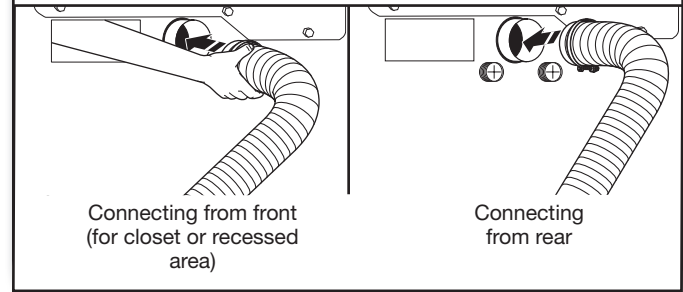

Using a 4" (102 mm) clamp, connect vent to exhaust outlet in dryer. If connecting to existing vent, make sure vent is clean. Dryer vent must fit over dryer exhaust outlet and inside exhaust hood. Check that vent is secured to exhaust hood with a 4" (102 mm) clamp.

2. Move washer/dryer to final location

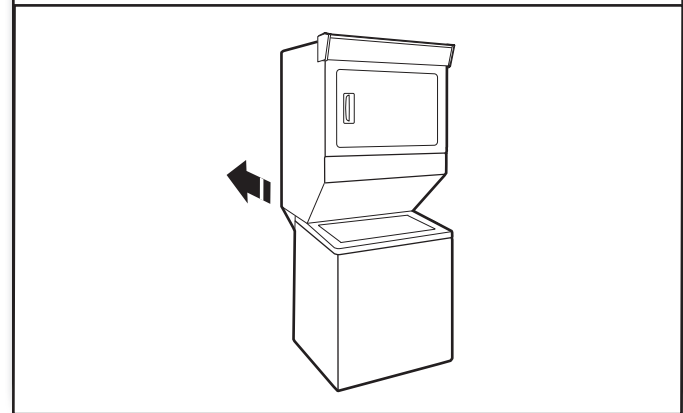

Move washer/dryer to final location, taking care not to crush or kink vent.

After washer/dryer is in place, remove corner posts and cardboard from under washer/dryer.

Final Installation Steps

Level Washer/Dryer

IMPORTANT: Level washer/dryer properly to reduce excess noise and vibration.

1. Check levelness of washer/dryer

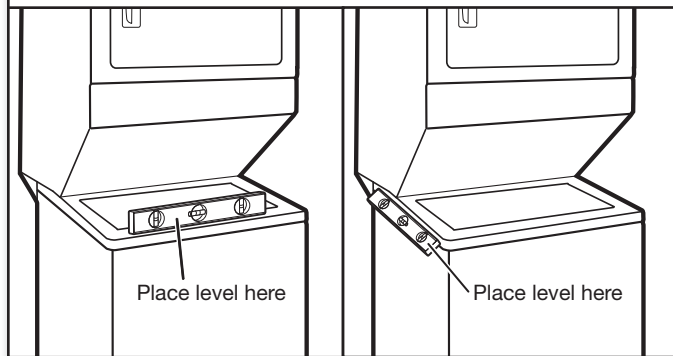

With washer/dryer in its final location, place a level on top edges of washer/dryer. Use side seam as a guide to check levelness of sides. Check levelness of front using lid, as shown. Rock washer/dryer back and forth to make sure all four feet make solid contact with floor. If washer/dryer is level, skip to step 3 (24" [61 cm] models) or "Install Anti-Tip Brackets" (27" [69 cm] models).

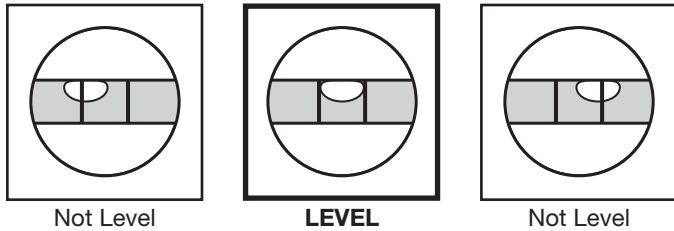

2. Adjust leveling feet (24" [61 cm] model shown)

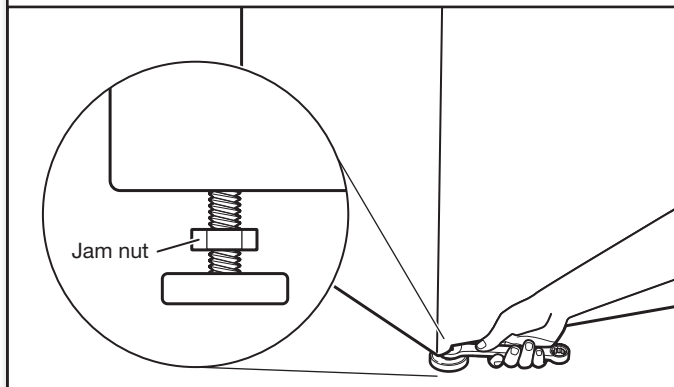

If washer/dryer is not level, prop up front of washer/dryer about 4" (102 mm) with a wood block or similar object that will support weight of washer/dryer.

On 24" (61 cm) models, use a 9/16" or 14 mm open-end or adjustable wrench to turn jam nuts clockwise on feet until they are about 1/2" (13 mm) from the washer/dryer cabinet. Then turn the leveling foot clockwise to lower the washer/dryer or counterclockwise to raise the washer/dryer.

On 27" (69 cm) models, adjust the feet up or down as necessary.

On all models, remove wood block and lower washer/dryer. Recheck levelness of washer/dryer and repeat as needed.

3. Tighten leveling feet (24" [61 cm] models)

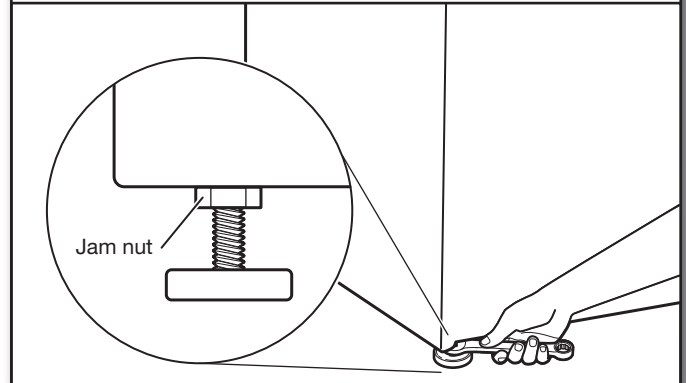

When washer/dryer is level, use a 9/16" or 14 mm open-end or adjustable wrench to turn jam nuts counterclockwise on leveling feet tightly against washer/dryer cabinet.

HELPFUL TIP: You may want to prop washer/dryer with a wooden block.

Install Anti-Tip Brackets (27" [69 cm] Models Only)

1. Attach anti-tip brackets

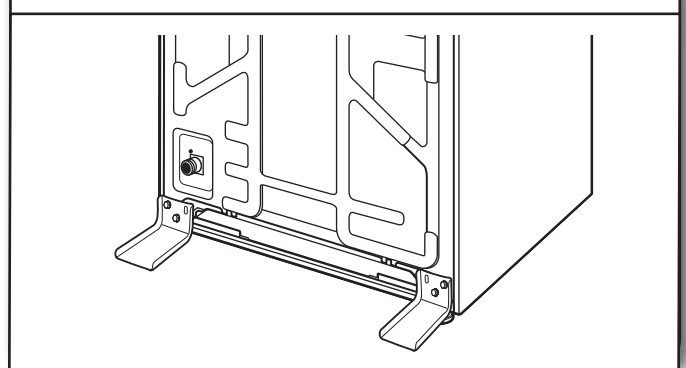

IMPORTANT: The anti-tip brackets must be installed on 27" (69 cm) models to avoid possible tipping backward of the washer/dryer.

With the washer/dryer in its final location, place anti-tip brackets at the lower left and lower right corners of the rear of the washer/dryer, aligning the screw holes in the brackets with the perforations in the cabinet, as shown.

Insert two of the provided screws in the top left and bottom holes in the left-hand bracket with a 1/4" (6.5 mm) nut driver or socket wrench and secure tightly to the washer/dryer cabinet. Repeat for the right-hand bracket using the top right and bottom holes.

Fasten Gas Washer/Dryer to Floor (Gas 27" [69 cm] Models Installed in Mobile Homes Only)

1. Fasten washer/dryer to floor

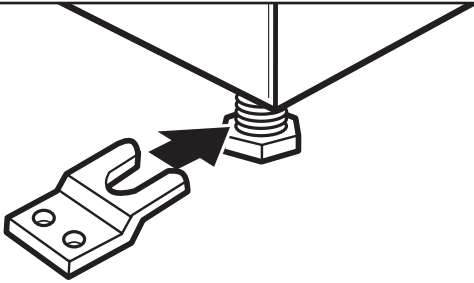

For mobile home use: Washer/dryers with gas dryers must be securely fastened to the floor.

Mobile home installations require a Mobile Home Installation Kit. See "Tools and Parts" for information on ordering.

Plug In Washer/Dryer: 27" (69 cm) Electric Models with Power Cord and 24" (61 cm) 240V Electric Models

In U.S.A.

⚠ WARNING



Electrical Shock Hazard

Plug into a grounded 3 or 4 prong outlet.

Do not remove ground prong.

Do not use an adapter.

Do not use an extension cord.

Failure to follow these instructions can result in death, fire, or electrical shock.

1. Plug into a grounded 3 or 4 prong outlet

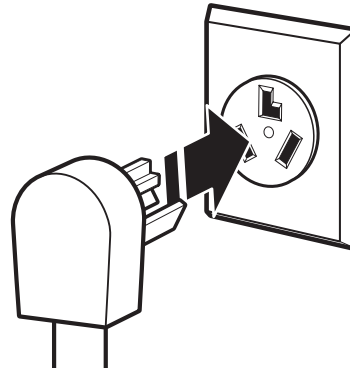

⚠ WARNING



Electrical Shock Hazard

Plug into a grounded 4 prong outlet.

Failure to do so can result in death or electrical shock.

1. Plug into a grounded 4 prong outlet

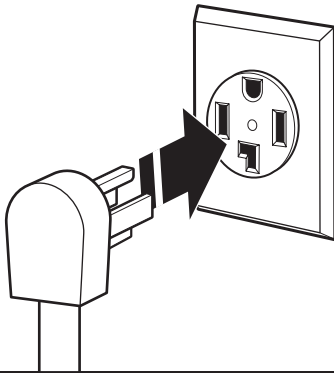

**Plug In Washer/Dryer:
27" (69 cm) Gas Models**

⚠ WARNING



Electrical Shock Hazard

Plug into a grounded 3 prong outlet.

Do not remove ground prong.

Do not use an adapter.

Do not use an extension cord.

**Failure to follow these instructions can result in death,
fire, or electrical shock.**

1. Plug into a grounded 3 prong outlet

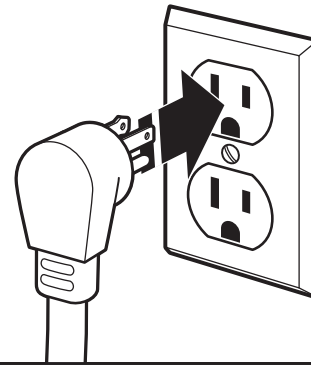

Plug In Washer/Dryer: 24" (61 cm) 120V Electric Models

⚠ WARNING



Electrical Shock Hazard

Plug into a grounded 3 prong outlet.

Do not remove ground prong.

Do not use an adapter.

Do not use an extension cord.

Failure to follow these instructions can result in death, fire, or electrical shock.

1. Plug into a grounded 3 prong 20 amp (5-20R) outlet

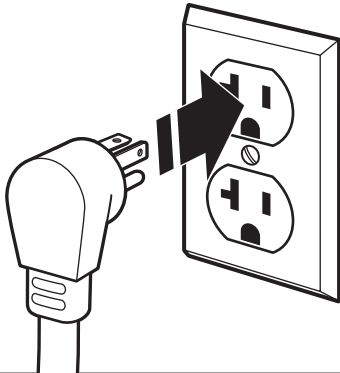

Complete Installation Checklist

- Check that all parts are now installed. If there is an extra part, go back through the steps to see which step was skipped.
- Check that you have all of your tools.
- Dispose of/recycle all packaging materials. Keep the plastic foam (24" [61 cm] models) for use if the washer/dryer should be transported.
- Check the washer/dryer's final location. Be sure the vent is not crushed or kinked.
- Check that the washer/dryer is level and leveling feet are tight (24" [61 cm] models). See "Level Washer/Dryer."

Electric Models (In the U.S.A.):

- 240V models: For power supply cord installation, plug into a grounded 4 prong or 3 prong outlet. For direct wire installation (27" [69 cm] models only), turn on power.
- 120V models: Plug into a grounded 3 prong 20 amp outlet.

Electric Models (In Canada):

- 240V models: Plug into a grounded 4 prong outlet.
- 120V models: Plug into a grounded 3 prong 20 amp outlet.

Gas Models (In the U.S.A. and Canada):

- Plug into a grounded 3 prong outlet.

All Models (In the U.S.A. and Canada):

- Check that the water faucets are on.
- Check for leaks around faucets and inlet hoses.
- Remove the film on the console and any tape remaining on the washer/dryer.
- Read the Washer/Dryer Use and Care Guide.
- Wipe the dryer drum interior thoroughly with a damp cloth to remove any dust.
- To test the washer, measure 1/2 the normal recommended amount of detergent and pour it into the washer. Close the lid. Select Heavy Duty or Heavy (depending on model) and push START/PAUSE. Allow the washer to complete one whole cycle.
- To test the dryer, set the dryer on a full heat cycle (not an air cycle) for 20 minutes and start the dryer.

If the dryer will not start, check the following:

- Controls are set in a running or On position.
- Start button has been firmly pushed.
- Washer/dryer is plugged into a grounded outlet.
- Electrical supply is connected.
- Household fuses are intact and tight, or circuit breakers have not tripped.
- Dryer door is closed.

- When the dryer has been running for 5 minutes, open the dryer door and feel for heat.

If you do not feel heat, turn off the dryer and check the following:

- Electric dryers: There may be two household fuses or circuit breakers for the dryer. Check that both fuses are intact and tight, or that both circuit breakers have not tripped. If there is still no heat, contact a qualified technician.
- Gas dryers: Check whether the gas supply line shut-off valve is open. If it is closed, open it, then repeat the 5-minute test as outlined above. If it is open, contact a qualified technician.

NOTE: On electric models, you may notice an odor when the dryer is first heated. This odor is common when the heating element is first used. The odor will go away.

