

# Poulan PRO

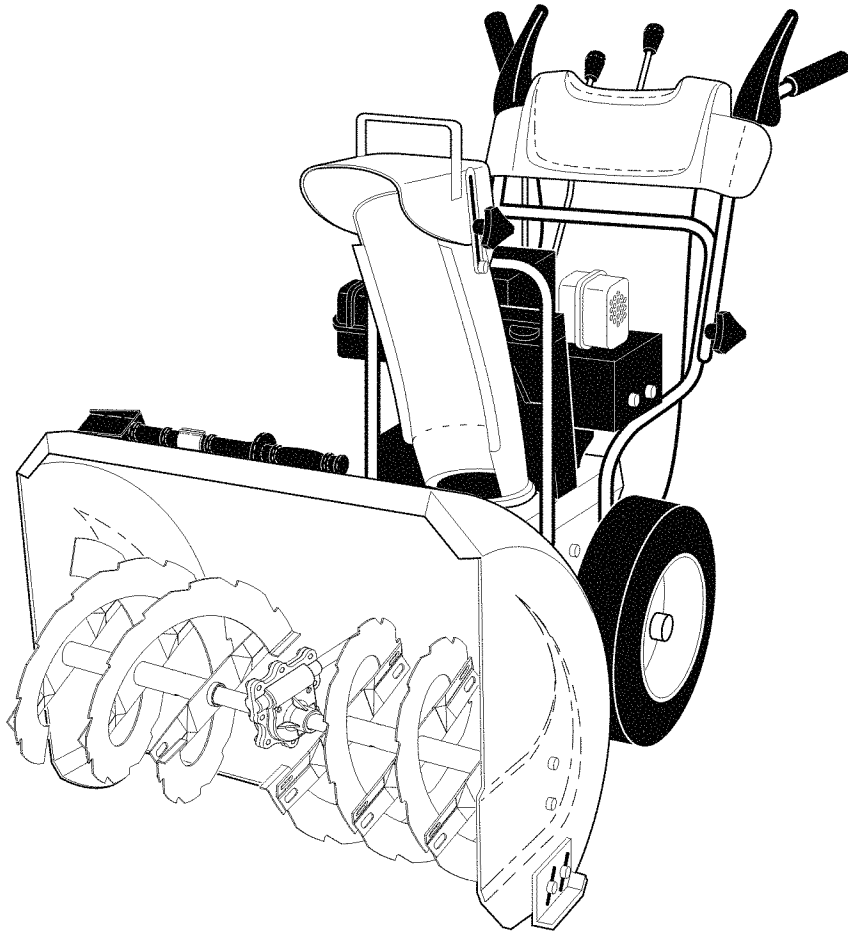

## OWNER'S MANUAL

**MODEL NUMBER:**  
**PR624ES**  
**SNOW THROWER**

**⚠ WARNING:**  
Read the Owner's Manual and follow all Warnings and Safety Instructions. Failure to do so can result in serious injury.

Gasoline containing up to 10% ethanol (E10) is acceptable for use in this machine. The use of any gasoline exceeding 10% ethanol (E10) will void the product warranty.

**Always Wear Eye Protection During Operation**

# IMPORTANT

## Safe Operation Practices for Walk-Behind Snow Throwers

This snow thrower is capable of amputating hands and feet and throwing objects. Failure to observe the following safety instructions could result in serious injury.



Look for this symbol to point out important safety precautions. It means **CAUTION!!! BECOME ALERT!!! YOUR SAFETY IS INVOLVED.**



**WARNING:** Always disconnect spark plug wire and place it where it cannot contact plug in order to prevent accidental starting when setting up, transporting, adjusting or making repairs.



**WARNING:** This snow thrower is for use on sidewalks, driveways and other ground level surfaces. Caution should be exercised while using on sloping surfaces. Do not use snow thrower on surfaces above ground level such as roofs of residences, garages, porches or other such structures or buildings.



**WARNING:** Snow throwers have exposed rotating parts, which can cause severe injury from contact, or from material thrown from the discharge chute. Keep the area of operation clear of all persons, small children and pets at all times including startup.



**CAUTION:** Muffler and other engine parts become extremely hot during operation and remain hot after engine has stopped. To avoid severe burns on contact, stay away from these areas.



**WARNING:** Engine exhaust, some of its constituents, and certain vehicle components contain or emit chemicals known to the State of California to cause cancer and birth defects or other reproductive harm.

### Training

1. Read, understand and follow all instructions on the machine and in the manual(s) before operating this unit. Be thoroughly familiar with the controls and the proper use of the equipment. Know how to stop the unit and disengage the controls quickly.
2. Never allow children to operate the equipment. Never allow adults to operate the equipment without proper instruction.
3. Keep the area of operation clear of all persons, particularly small children.
4. Exercise caution to avoid slipping or falling, especially when operating the snow thrower in reverse.

### Preparation

1. Thoroughly inspect the area where the equipment is to be used and remove all doormats, sleds, boards, wires, and other foreign objects.
2. Disengage all clutches and shift into neutral before starting the engine (motor).
3. Do not operate the equipment without wearing adequate winter garments. Avoid loose fitting clothing that can get caught in moving parts. Wear footwear that will improve footing on slippery surfaces.
4. Handle fuel with care; it is highly flammable
  - (a) Use an approved fuel container.
  - (b) Never add fuel to a running engine or hot engine.
  - (c) Fill fuel tank outdoors with extreme care. Never fill fuel tank indoors.
  - (d) Never fill containers inside a vehicle or on a truck or trailer bed with a plastic liner. Always place containers on the ground, away from your vehicle, before filling.
  - (e) When practical, remove gas-powered equipment from the truck or trailer and refuel it on the ground. If this is not possible, then refuel such equipment on a trailer with a portable container, rather than from a gasoline dispenser nozzle.

- (f) Keep the nozzle in contact with the rim of the fuel tank or container opening at all times, until refueling is complete. Do not use a nozzle lock-open device.
  - (g) Replace gasoline cap securely and wipe up spilled fuel.
  - (h) If fuel is spilled on clothing, change clothing immediately.
5. Use extension cords and receptacles as specified by the manufacturer for all units with electric drive motors or electric starting motors.
  6. Adjust the collector housing height to clear gravel or crushed rock surface.
  7. Never attempt to make any adjustments while the engine (motor) is running (except when specifically recommended by manufacturer).
  8. Always wear safety glasses or eye shields during operation or while performing an adjustment or repair to protect eyes from foreign objects that may be thrown from the machine.

### Operation

1. Do not put hands or feet near or under rotating parts. Keep clear of the discharge opening at all times.
2. Exercise extreme caution when operating on or crossing gravel drives, walks, or roads. Stay alert for hidden hazards or traffic.
3. After striking a foreign object, stop the engine (motor), remove the wire from the spark plug, disconnect the cord on electric motors, thoroughly inspect the snow thrower for any damage, and repair the damage before restarting and operating the snow thrower.
4. If the unit should start to vibrate abnormally, stop the engine (motor) and check immediately for the cause. Vibration is generally a warning of trouble.
5. Stop the engine (motor) whenever you leave the operating position, before unclogging the collector/impeller housing or discharge chute, and when making any repairs, adjustments or inspections.

6. When cleaning, repairing or inspecting the snow thrower, stop the engine and make certain the collector/impeller and all moving parts have stopped. Disconnect the spark plug wire and keep the wire away from the plug to prevent someone from accidentally starting the engine.
7. Do not run the engine indoors, except when starting the engine and for transporting the snow thrower in or out of the building. Open the outside doors; exhaust fumes are dangerous.
8. Exercise extreme caution when operating on slopes.
9. Never operate the snow thrower without proper guards, and other safety protective devices in place and working.
10. Never direct the discharge toward people or areas where property damage can occur. Keep children and others away.
11. Do not overload the machine capacity by attempting to clear snow at too fast a rate.
12. Never operate the machine at high transport speeds on slippery surfaces. Look behind and use care when operating in reverse.
13. Disengage power to the collector/impeller when snow thrower is transported or not in use.
14. Use only attachments and accessories approved by the manufacturer of the snow thrower (such as wheel weights, counterweights, or cabs).
15. Never operate the snow thrower without good visibility or light. Always be sure of your footing, and keep a firm hold on the handles. Walk; never run.

16. Never touch a hot engine or muffler.

### Clearing a Clogged Discharge Chute

Hand contact with the rotating impeller inside the discharge chute is the most common cause of injury associated with snow throwers. Never use your hand to clean out the discharge chute. To clear the chute:

1. SHUT THE ENGINE OFF!
2. Wait 10 seconds to be sure the impeller blades have stopped rotating.
3. Always use a clean-out tool, not your hands.

### Maintenance and Storage

1. Check shear bolts and other bolts at frequent intervals for proper tightness to be sure the equipment is in safe working condition.
2. Never store the machine with fuel in the fuel tank inside a building where ignition sources are present such as hot water heaters, space heaters, or clothes dryers. Allow the engine to cool before storing in any enclosure.
3. Always refer to operator's manual for important details if the snow thrower is to be stored for an extended period.
4. Maintain or replace safety and instruction labels, as necessary.
5. Run the machine a few minutes after throwing snow to prevent freeze-up of the collector/impeller.

**CONGRATULATIONS** on your purchase of a new snow thrower. It has been designed, engineered and manufactured to give best possible dependability and performance.

Should you experience any problem you cannot easily remedy, please contact your nearest authorized service center. We have competent, well-trained technicians and the proper tools to service or repair this unit.

Please read and retain this manual. The instructions will enable you to assemble and maintain your snow thrower properly. Always observe the "SAFETY RULES".

SERIAL NUMBER: \_\_\_\_\_

DATE OF PURCHASE: \_\_\_\_\_

THE MODEL AND SERIAL NUMBERS WILL BE FOUND ON A DECAL ATTACHED TO THE REAR OF THE SNOW THROWER HOUSING.

YOU SHOULD RECORD BOTH SERIAL NUMBER AND DATE OF PURCHASE AND KEEP IN A SAFE PLACE FOR FUTURE REFERENCE.

### PRODUCT SPECIFICATIONS

<b>Gasoline Capacity and Type:</b>	.5 Gal (1,89 Liters) Unleaded Regular only
<b>Oil Type (API SG-SL):</b>	SAE 30 (above 50°F) SAE 5W-30 or 10W-30 (32° to 50°F) SAE 5W-30 (below 32°F)
<b>Oil Capacity:</b>	16 Ounces (0,47 Liters)
<b>Spark Plug: Gap:</b>	Champion F6RTC 0.030" (0,762 mm)

### CUSTOMER RESPONSIBILITIES

- Read and observe the safety rules.
- Follow a regular schedule in maintaining, caring for and using your snow thrower.
- Follow the instructions under "Maintenance" and "Storage" sections of this owner's manual.

## TABLE OF CONTENTS

<b>SAFETY RULES</b> .....	<b>2-3</b>
<b>PRODUCT SPECIFICATIONS</b> .....	<b>3</b>
<b>CUSTOMER RESPONSIBILITIES</b> .....	<b>3</b>
<b>ASSEMBLY / PRE-OPERATION</b> .....	<b>4-7</b>
<b>OPERATION</b> .....	<b>8-12</b>
<b>MAINTENANCE SCHEDULE</b> .....	<b>13</b>
<b>MAINTENANCE</b> .....	<b>13-14</b>

<b>SERVICE AND ADJUSTMENTS</b> .....	<b>15-17</b>
<b>STORAGE</b> .....	<b>18</b>
<b>TROUBLESHOOTING</b> .....	<b>19</b>
<b>REPAIR PARTS</b> .....	<b>20-37</b>
<b>ENGINE BREAKDOWN</b> .....	<b>38-39</b>
<b>WARRANTY</b> .....	<b>BACK COVER</b>

# PARTS PACKED SEPARATELY IN CARTON

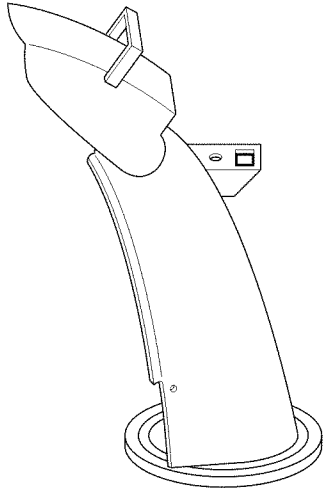

(1) DISCHARGE CHUTE

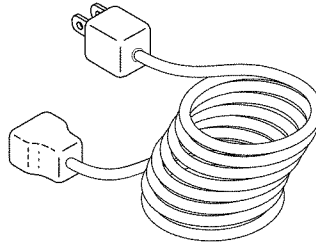

(1) POWER CORD  
(198563)

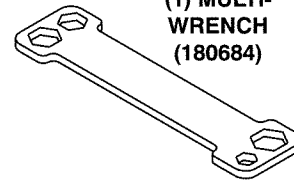

(1) MULTI-  
WRENCH  
(180684)

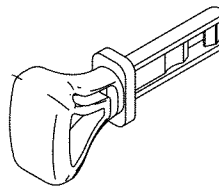
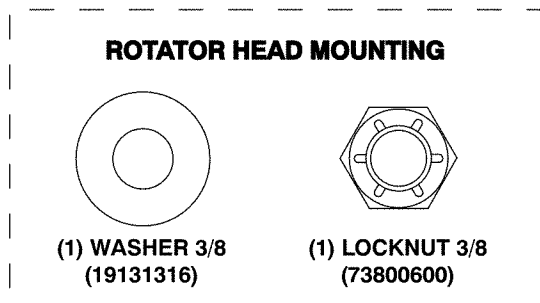

SAFETY IGNITION KEY(S)  
(443059)

(1) RETAINER  
SPRING  
(169675)

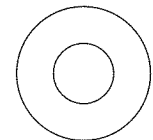
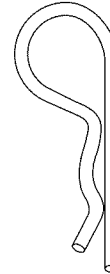

(2) FLAT WASHERS

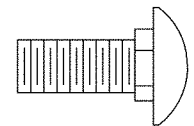

(2) CARRIAGE BOLTS  
3/8-16 x 2.25

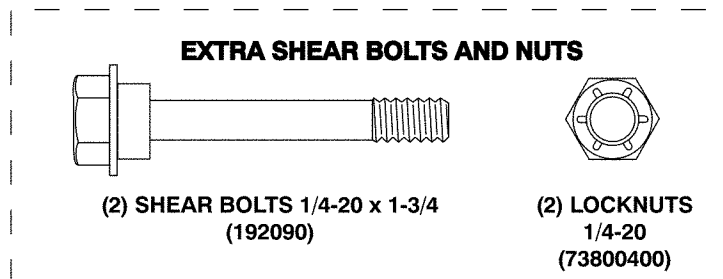

(2) HANDLE KNOBS

## ASSEMBLY / PRE-OPERATION

Read these instructions and this manual in its entirety before you attempt to assemble or operate your new snow thrower. Reading the entire manual will familiarize you with the unit, which will assist you in assembly, operation and maintenance of the product.

Your new snow thrower has been assembled at the factory with the exception of those parts left unassembled for shipping purposes. All parts such as nuts, washers, bolts, etc., necessary to complete the assembly have been placed in the parts bag. To ensure safe and proper operation of your snow thrower, all parts and hardware you assemble must be tightened securely. Use the correct tools as necessary to ensure proper tightness.

### REMOVE SNOW THROWER FROM CARTON

1. Remove all accessible loose parts and parts boxes from carton.

2. Cut down all four corners of carton and lay panels flat.
3. Remove the two (2) screws securing the auger housing to the pallet.
4. Remove all packing materials except plastic tie holding speed control rod to lower handle.
5. Remove the two (2) plastic ties securing the upper handle to the pallet.
6. Remove snow thrower from carton and check carton thoroughly for additional loose parts.

### HOW TO SET UP YOUR SNOW THROWER

#### TOOL BOX (See Fig. 8)

A toolbox is provided on your snow thrower. The toolbox is located on top of the belt cover. Store the extra shear bolts, nuts and multi-wrench provided in parts bag in the toolbox.

# ASSEMBLY / PRE-OPERATION

**NOTE:** The multi-wrench may be used for assembly of the chute rotator head to snow thrower and making adjustments to the skid plates.

## UNFOLD UPPER HANDLE

1. Raise upper handle to the operating position and tighten handle knobs securely. Additional carriage bolts, washers and handle knobs are in bag of parts. Use to secure upper handle to lower handle. Install in lower holes in handles.

## INSTALL SPEED CONTROL ROD (See Figs. 1 and 2)

1. Remove plastic tie securing rod to lower handle.
2. Insert rod into speed control bracket and secure with retainer spring.

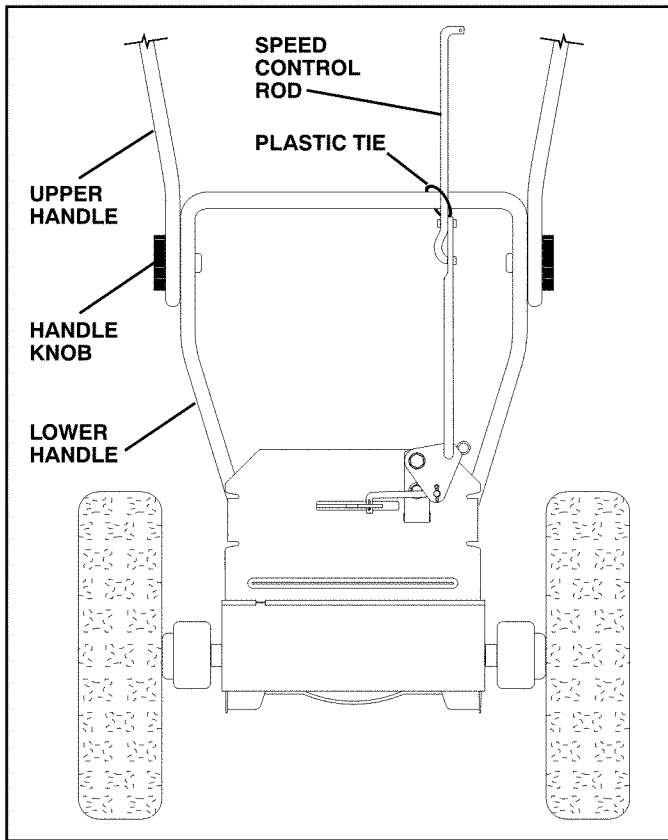

FIG. 1

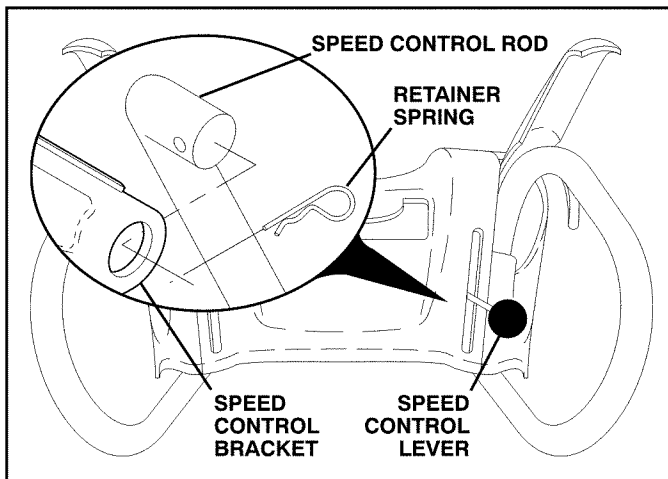

FIG. 2

## INSTALL TRACTION DRIVE CONTROL ROD

(See Figs. 3 and 4)

The traction drive control rod is installed on the snow thrower.

1. Remove plastic tie securing traction drive control rod to rotator bracket.
2. With top end of rod positioned under left side of control panel, push rod down and insert top end of rod into hole in traction drive control lever. Snap rod into place by pushing down.

**NOTE:** Engage lever once and rod should snap into place.

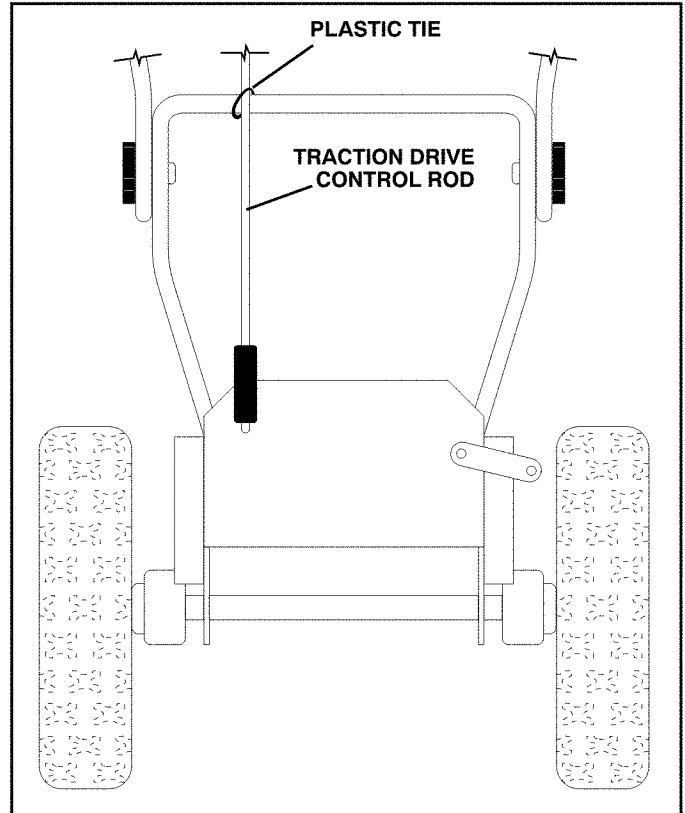

FIG. 3

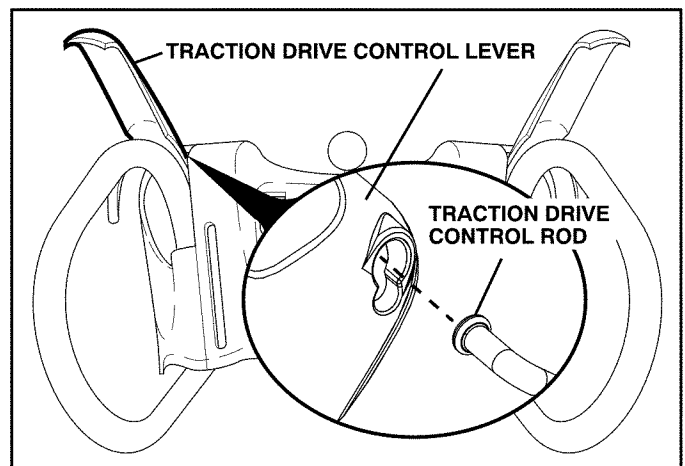

FIG. 4

# ASSEMBLY / PRE-OPERATION

## INSTALL AUGER CONTROL ROD (See Figs. 5 and 6)

The auger control rod is installed on the snow thrower.

1. Remove plastic tie securing auger control rod to lower handle. (See Fig. 5).
2. Push down on the auger control rod and bring top end of rod up between the metal console and plastic console cover at right control lever.
3. With control lever in the raised position, insert end of control rod in slot of control lever.

**NOTE:** Engage lever once and rod should snap into place.

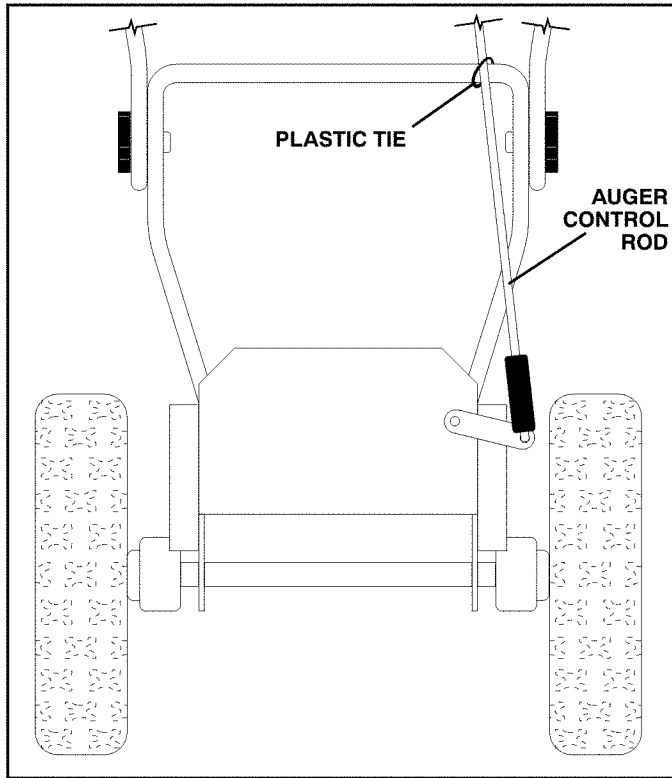

FIG. 5

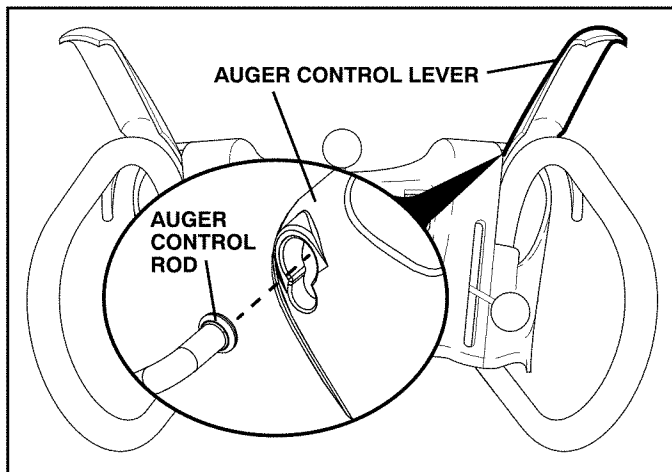

FIG. 6

## INSTALL DISCHARGE CHUTE / CHUTE ROTATER HEAD (See Fig. 7)

**NOTE:** The multi-wrench provided in your parts bag may be used to install the chute rotater head.

1. Place discharge chute assembly on top of chute base with discharge opening toward front of snow thrower.
2. Position chute rotater head over chute bracket. If necessary, rotate chute assembly to align square and pin on underside of chute rotater head with holes in chute bracket.
3. With chute rotater head and chute bracket aligned, position chute rotater head on pin and threaded stud of mounting bracket.
4. Install 3/8 washer and locknut on threaded stud and tighten securely.

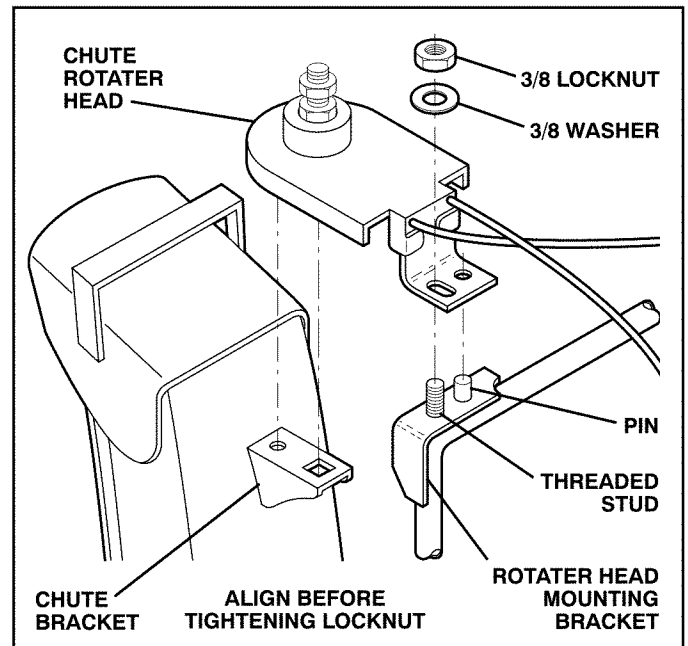

FIG. 7

## CHECK TIRE PRESSURE

The tires on your snow thrower were overinflated at the factory for shipping purposes. Correct and equal tire pressure is important for best snow throwing performance.

- Reduce tire pressure to 14-17 PSI.

# OPERATION

## KNOW YOUR SNOW THROWER

READ THIS OWNER'S MANUAL AND ALL SAFETY RULES BEFORE OPERATING YOUR SNOW THROWER. Compare the illustrations with your snow thrower to familiarize yourself with the location of various controls and adjustments. Save this manual for future reference.

These symbols may appear on your snow thrower or in literature supplied with the product. Learn and understand their meaning.

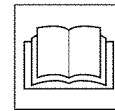
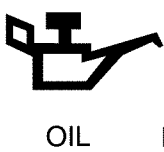
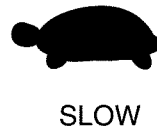

**READ AND FOLLOW ALL SAFETY INFORMATION AND INSTRUCTIONS BEFORE USE OF THIS PRODUCT. KEEP THESE INSTRUCTIONS FOR FUTURE REFERENCE.**

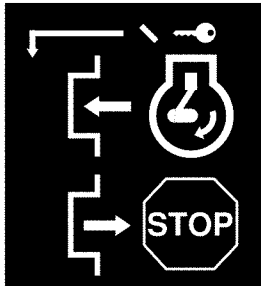

**IGNITION KEY. INSERT TO START AND RUN, PULL OUT TO STOP.**

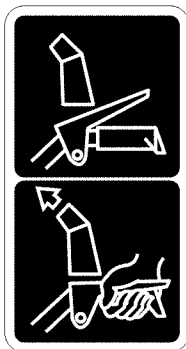

**SNOW DISCHARGE**

**DISENGAGED**

**ENGAGED**

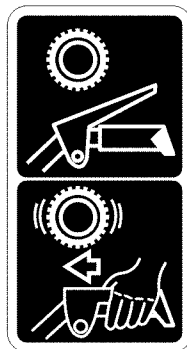

**TRACTION DRIVE CONTROL**



# OPERATION

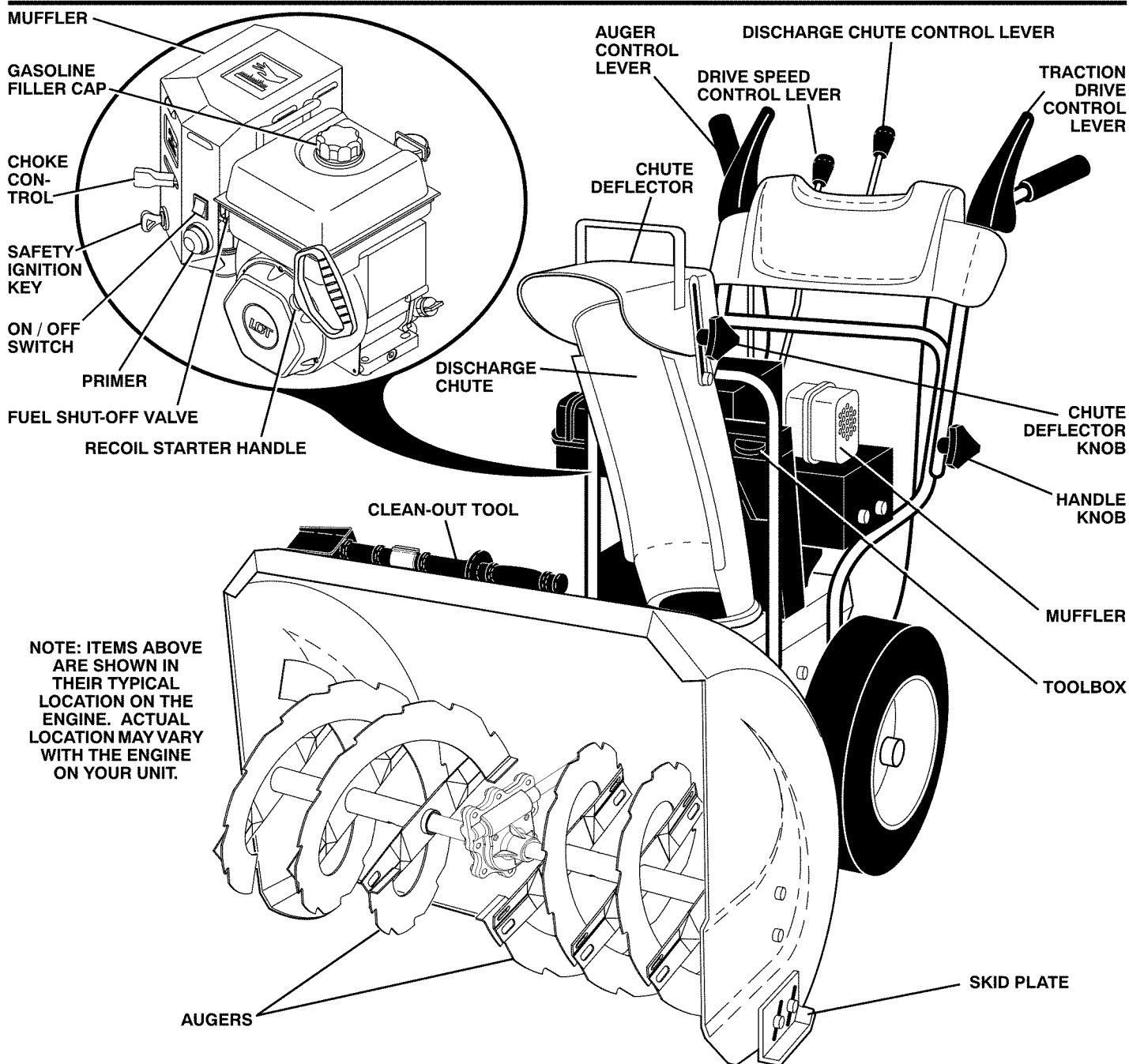

FIG. 8

## MEETS A.N.S.I. SAFETY REQUIREMENTS

Our snow throwers conform to the standards of the American National Standards Institute.

**Toolbox** - used to store spare shear bolts, locknuts and wrench.

**Safety ignition key** - must be inserted for the engine to start and run. Remove when snow thrower is not in use.

**Electric start button** - used for starting the engine.

**Recoil (auxiliary) starter handle** - used for starting the engine.

**Primer** - pumps additional fuel from the carburetor to the cylinder for use when starting a cold engine.

**ON / OFF switch** - used to STOP the engine.

**Choke control** - used for starting a cold engine.

**Drive speed control lever** - used to select forward or reverse motion and speed of snow thrower.

**Traction drive control lever** - used to engage power-propelled forward or reverse motion of snow thrower.

**Auger control lever** - used to engage auger motion (throw snow).

**Discharge chute control lever** - used to change the direction the snow is thrown.

**Skid plate** - used to adjust height of scraper bar from the ground.



# OPERATION



The operation of any snow thrower can result in foreign objects thrown into the eyes, which can result in severe eye damage. Always wear safety glasses or eye shields while operating your snow thrower or performing any adjustments or repairs. We recommend standard safety glasses or a wide vision safety mask worn over spectacles.

## HOW TO USE YOUR SNOW THROWER

**Know how** to operate all controls before adding fuel or attempting to start the engine.

### STOPPING

#### TRACTION DRIVE

- Release traction drive control lever to stop the forward or reverse movement of the snow thrower.

#### AUGER

- Release the auger control lever to stop throwing snow.

#### ENGINE

1. Move ON / OFF switch to "OFF" position.
2. Remove (do not turn) safety ignition key to prevent unauthorized use.

**NOTE:** Never use choke to stop engine.

### TO USE FUEL SHUT-OFF VALVE (See Fig. 9)

The fuel shut-off valve is located beneath the fuel tank on the engine. Always operate the snow thrower with the fuel shut-off valve in the OPEN position.

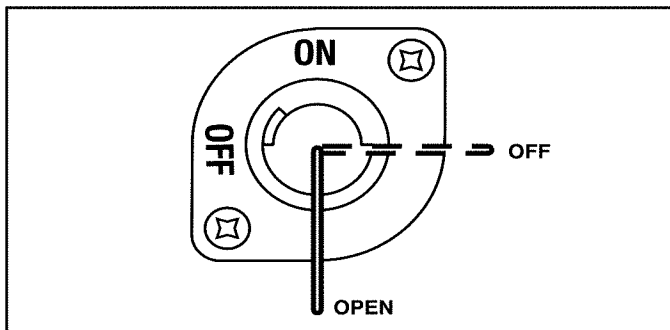

FIG. 9

### TO USE CHOKE CONTROL (See Fig. 10)

The choke control is located on the engine. Use the choke control whenever you are starting a cold engine. Do not use to start a warm engine.

- To engage choke, move lever to "FULL" position.

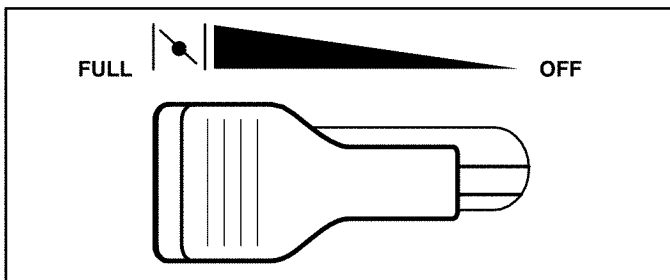

FIG. 10

### TO CONTROL SNOW DISCHARGE (See Figs. 11 & 12)



**WARNING:** Snow throwers have exposed rotating parts, which can cause severe injury from contact, or from material thrown from the discharge chute. Keep the area of operation clear of all persons, small children and pets at all times including startup.



**WARNING:** If the discharge chute or auger become clogged, shut-off engine and wait for all moving parts to stop. Use the clean-out tool, NOT YOUR HANDS, to unclog the chute and/or auger.

The DIRECTION in which snow is to be thrown is controlled by the discharge chute control lever.

- To change the discharge chute position, press downward on discharge chute control lever and move lever left or right until chute is in desired position. Be sure lever springs back and locks into desired position.

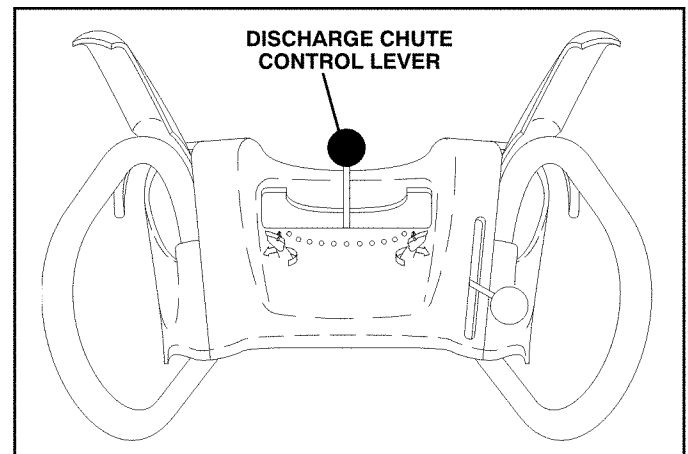

FIG. 11

The DISTANCE that snow is thrown is controlled by the position of the chute deflector. Set the deflector low to throw snow a short distance; set the deflector higher to throw snow farther.

- To change the deflector position, loosen knob, move deflector to desired position and tighten knob securely.

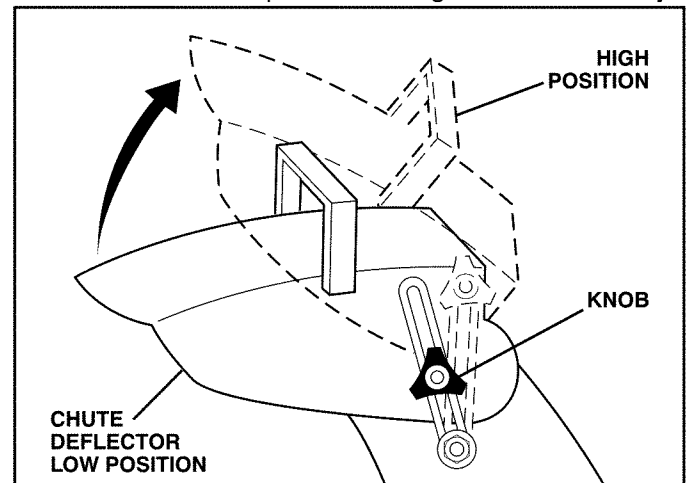

FIG. 12

# OPERATION

## TO THROW SNOW (See Fig. 13)

The auger rotation is controlled by the auger control lever located on the right side handle.

- Squeeze auger control lever to handle to engage the auger and throw snow.
- Release the auger control lever to stop throwing snow.

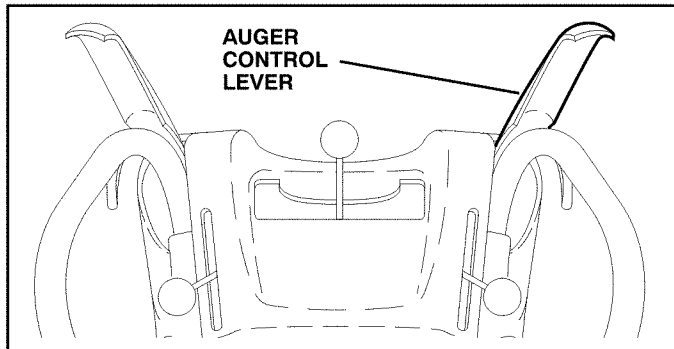

FIG. 13

## USING THE CLEAN-OUT TOOL (See Fig. 14)

In certain snow conditions, the discharge chute may become clogged with ice and snow. Use the clean-out tool to dislodge this blockage.

**When cleaning, repairing, or inspecting, make certain all controls are disengaged and the auger/impeller and all moving parts have stopped. Disconnect the spark plug wire and keep the wire away from the spark plug to prevent accidental starting.**

- Release the auger control lever and shut off the engine.
- Remove the clean-out tool from its mounting clip. Grasp the tool firmly by the handle and push and twist the tool into the discharge chute to dislodge the blockage.

After the packed snow has been dislodged, return the clean-out tool to its mounting clip by pushing it into the clip.

- Make sure the discharge chute is pointed in a safe direction (no vehicles, buildings, people, or other objects are in the direction of discharge) before restarting engine.
- Restart the engine, then squeeze the auger control lever to the handle to clear snow from the auger housing and the discharge chute.

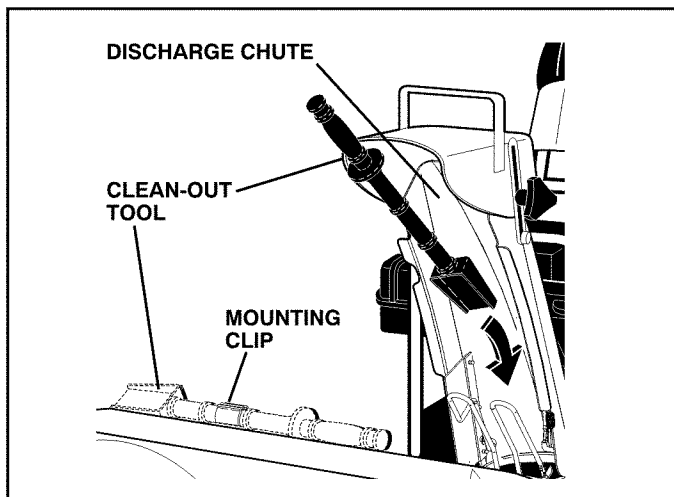

FIG. 14

## TO MOVE FORWARD AND BACKWARD (See Fig. 15)

SELF-PROPELLING, forward and reverse movement of the snow thrower, is controlled by the traction drive control lever located on the left side handle.

- Squeeze traction drive control lever to handle to engage the drive system.
- Release traction drive control lever to stop the forward or reverse movement of the snow thrower.

SPEED and DIRECTION are controlled by the drive speed control lever.

- Press downward on the speed control lever and move lever to desired position BEFORE engaging the traction drive control lever. Be sure lever springs back and locks into desired position.

**CAUTION: Do not move speed control lever when traction drive control lever is engaged. Damage to the snow thrower can result.**

- Slower speeds are for heavier snow and faster speeds are for light snow and transporting the snow thrower. It is recommended that you use a slower speed until you are familiar with the operation of the snow thrower.

**NOTE:** When both traction drive and auger control levers are engaged, the traction drive control lever will lock the auger control lever in the engaged position. This will allow you to release your right hand from the handle and adjust the discharge chute direction without interrupting the snow throwing process.

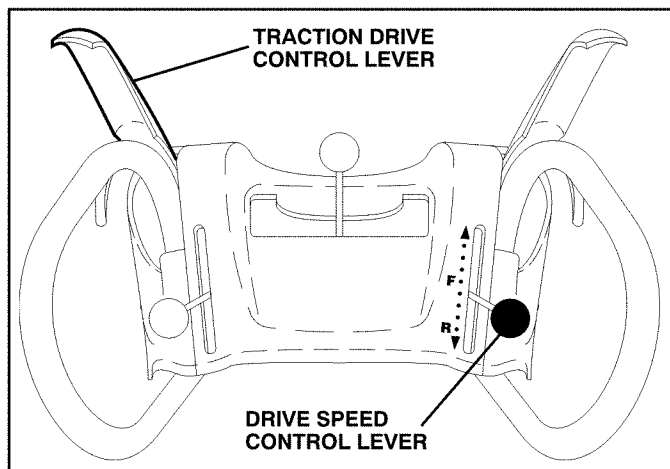

FIG. 15

# OPERATION

## TO ADJUST SKID PLATES (See Fig. 16)

**NOTE:** The wrench provided in your parts bag may be used to adjust the skid plates.

Skid plates are located on each side of the auger housing and adjust the clearance between the scraper bar and the ground surface. Adjust skid plates evenly to proper height for current surface conditions. For removal of snow in normal conditions, such as a paved driveway or sidewalk, place skid plates in the highest position (lowest scraper clearance) to give a 1/8" clearance between the scraper bar and the ground. Use a middle position if the surface to be cleared is uneven.

**NOTE:** It is not recommended to operate the snow thrower over gravel or rocky surfaces. Objects such as gravel, rocks or other debris, can easily be picked up and thrown by the impeller, which can cause serious personal injury, property damage or damage to the snow thrower.

- If snow thrower must be operated over gravel surface, use extra caution and be sure skid plates are adjusted to lowest (highest scraper clearance) position.
1. Shut off engine and wait for all moving parts to stop.
  2. Adjust skid plates by loosening the hex nuts, then moving skid plate to desired position. Be sure both plates are adjusted evenly. Tighten securely.

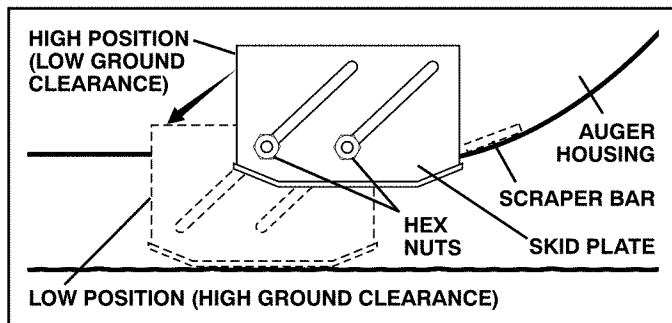

FIG. 16

## SCRAPER BAR (See Fig. 16)

The scraper bar is not adjustable, but is reversible. After considerable use it may become worn. When it has worn almost to the edge of the housing, it can be reversed, providing additional service before requiring replacement. Replace a damaged or worn scraper bar.

## BEFORE STARTING THE ENGINE

### CHECK ENGINE OIL LEVEL (See Fig. 17)

The engine on your snow thrower has been shipped from the factory already filled with oil.

1. Check engine oil with snow thrower on level ground.
  2. Remove oil fill cap/dipstick and wipe clean, reinsert the dipstick and screw tight, wait for a few seconds, remove and read oil level. If necessary, add oil until "FULL" mark on dipstick is reached. Do not overfill.
- To change engine oil, see "TO CHANGE ENGINE OIL" in the Maintenance section of this manual.

## ADD GASOLINE (See Fig. 17)

- Fill fuel tank to bottom of tank filler neck. Do not overfill. Use fresh, clean, regular unleaded gasoline with a minimum of 87 octane. Do not mix oil with gasoline. Purchase fuel in quantities that can be used within 30 days to assure fuel freshness.



**WARNING:** Wipe off any spilled oil or fuel. Do not store, spill or use gasoline near an open flame.

**CAUTION:** Alcohol blended fuels (called gasohol or using ethanol or methanol) can attract moisture which leads to separation and formation of acids during storage. Acidic gas can damage the fuel system of an engine while in storage. To avoid engine problems, the fuel system should be emptied before storage of 30 days or longer. Empty the gas tank, start the engine and let it run until the fuel lines and carburetor are empty. Use fresh fuel next season. See Storage Instructions for additional information. Never use engine or carburetor cleaner products in the fuel tank or permanent damage may occur.

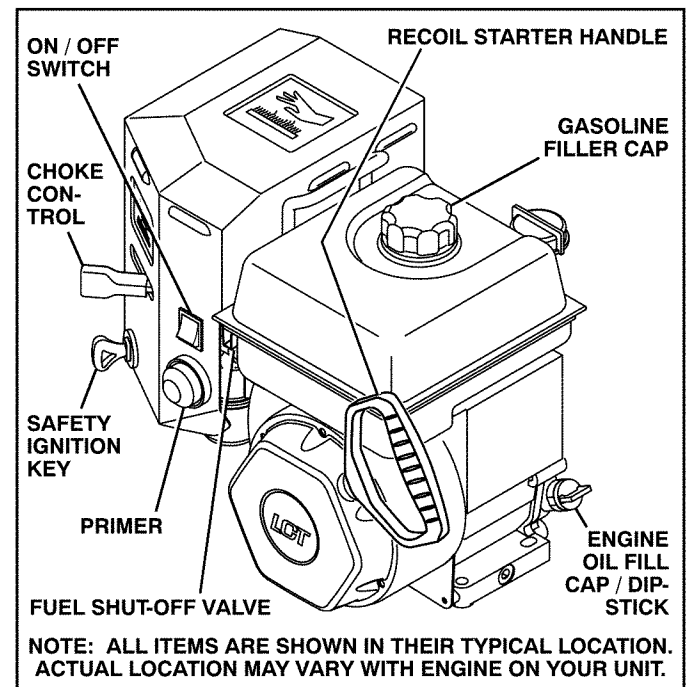

FIG. 17

---

# OPERATION

---

## TO START ENGINE

- Be sure fuel shut-off valve is in the “OPEN” position.

Your snow thrower engine is equipped with a recoil starter.

### COLD START

1. Insert safety ignition key (tied to recoil start cord) into ignition slot until it clicks. **DO NOT** turn the key. Keep the extra safety ignition key in a safe place.
2. Place ON / OFF switch in “ON” position.
3. Rotate choke control to “FULL” position.
4. Push the primer four (4) times if the temperature is below 15°F, or two (2) times if temperature is between 15° and 50°F. If temperature is above 50°F, priming is not necessary.

**NOTE:** Over priming may cause flooding, preventing the engine from starting. If you do flood the engine, wait a few minutes before attempting to start and **DO NOT** push the primer.

5. Pull recoil starter handle quickly. Do not allow starter rope to snap back.
6. When the engine starts, release the recoil starter handle and slowly move the choke control to the “OFF” position.

Allow the engine to warm up for a few minutes. Engine will not develop full power until it has reached normal operating temperature.

### WARM START

Follow the steps above, keeping the choke in the “OFF” position. **DO NOT** push the primer.

### BEFORE STOPPING

Run the engine for a few minutes to help dry off any moisture on the engine.

### IF RECOIL STARTER HAS FROZEN

If the recoil starter has frozen and will not turn the engine, proceed as follows:

1. Grasp the recoil starter handle and slowly pull as much rope out of the starter as possible.
2. Release the recoil starter handle and let it snap back against the starter.

If the engine still fails to start, repeat the above steps.

## SNOW THROWING TIPS

- Go slower in deep, freezing or heavy wet snow. Use the drive speed control, **NOT** the ON / OFF switch, to adjust speed.
- It is easier and more efficient to remove snow immediately after it falls.
- The best time to remove snow is the early morning. At this time the snow is usually dry and has not been exposed to the direct sun and warming temperatures.
- Slightly overlap each successive path to ensure all snow will be removed.
- Throw snow downwind whenever possible.
- Adjust the skid plates to proper height for current snow conditions. See “TO ADJUST SKID PLATES” in this section of this manual.
- For extremely heavy snow, reduce the width of snow removal by overlapping previous path and moving slowly.
- Keep engine clean and clear of snow during use. This will help air flow and extend engine life.
- After snow-throwing is completed, allow engine to run for a few minutes to melt snow and ice off the engine.
- Clean the entire snow thrower thoroughly after each use and wipe dry so it is ready for next use.



**WARNING: Do not operate snow thrower if weather conditions impair visibility. Throwing snow during a heavy, windy snowstorm can blind you and be hazardous to the safe operation of the snow thrower.**

# MAINTENANCE

<b>MAINTENANCE SCHEDULE</b>		BEFORE EACH USE AFTER EACH USE EVERY 25 HOURS OR EVERY SEASON EVERY 50 HOURS EVERY 100 HOURS BEFORE STORAGE						SERVICE DATES	
<b>T H R O W E R</b>	Check for Loose Fasteners	✓					✓		
	Clean / Inspect Snow Thrower		✓				✓		
	Check / Replace V-Belts				✓				
	Lubrication Chart			✓			✓		
<b>E N G I N E</b>	Check Engine Oil Level	✓							
	Change Engine Oil			✓					
	Inspect Muffler				✓				
	Check / Replace Spark Plug					✓			
	Empty Fuel Tank						✓		

## GENERAL RECOMMENDATIONS

The warranty on this snow thrower does not cover items that have been subjected to operator abuse or negligence. To receive full value from the warranty, operator must maintain snow thrower as instructed in this manual. Some adjustments will need to be made periodically to properly maintain your snow thrower.

At least once a season, check to see if you should make any of the adjustments described in the Service and Adjustments section of this manual.

- At least once a year, you should replace the spark plug and check belts for wear. A new spark plug will help your engine run better and last longer.
- Follow the maintenance schedule in this manual.

**NOTE:** Use only Original Equipment Manufacturer (OEM) parts to service this unit. Failure to do so can cause the unit to malfunction and pose a risk of injury to the operator.

## BEFORE EACH USE

1. Check engine oil level.
2. Check for loose fasteners.
3. Check controls to be sure they are functioning properly.

## LUBRICATION

Keep your snow thrower well lubricated (See "LUBRICATION CHART").

## LUBRICATION CHART

- ① SAE 30 Motor Oil
- ② See "ENGINE" in Maintenance section
- ③ General Purpose Grease

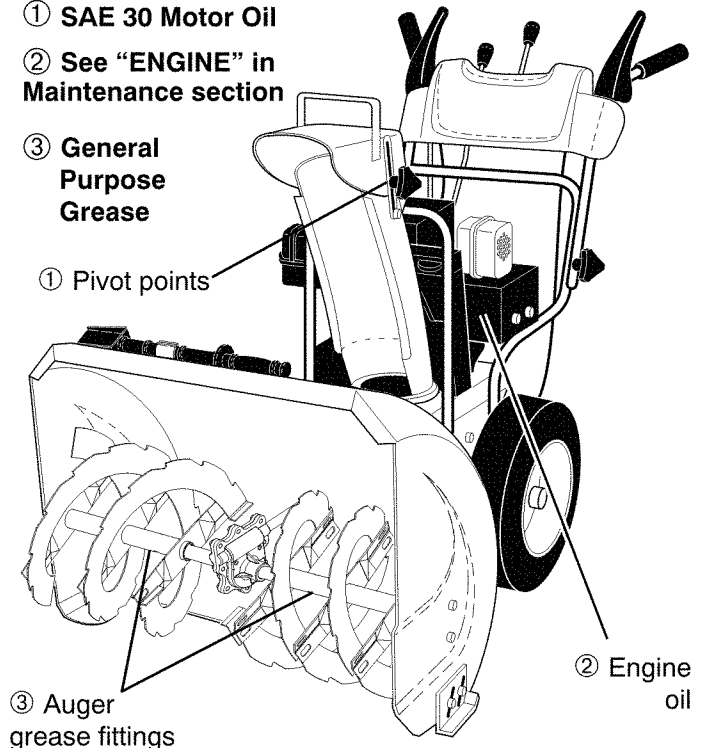

## SNOW THROWER

Always observe the safety rules when performing any maintenance.

## TIRES

- Maintain proper air pressure in both tires (14–17 P.S.I.).

- Keep tires free of gasoline and oil, which can harm rubber.

**NOTE:** To seal tire punctures and prevent flat tires due to slow leaks, tire sealant may be purchased from your local parts dealer. Tire sealant also prevents tire dry rot and corrosion.

# MAINTENANCE

## BELTS

Check belts for deterioration and wear after every 50 hours of operation and replace if necessary. The belts are not adjustable. Replace belts if they begin to slip from wear. (See "TO REMOVE BELT COVER" in the Service and Adjustments section of this manual).

The belts on your snow thrower are of special construction and should be replaced by original equipment manufacturer (OEM) belts available from your nearest dealer. Using other than OEM belts can cause personal injury or damage to the snow thrower.

## AUGER GEAR CASE

- The gear case was filled with lubricant to the proper level at the factory. The only time the lubricant needs attention is if service has been performed on the gear case.
- If lubricant is required, use only Ronex ED #1 grease.

## TRACTION DRIVE SYSTEM

DO NOT lubricate the drive components inside the snow thrower. The sprockets, hex shafts, drive disc and friction wheel require no lubrication. The bearings and bushings are lifetime lubricated and require no maintenance.

**CAUTION: Any lubricating of the above components can cause contamination of the friction wheel and damage to the drive system of your snow thrower.**

## ENGINE

See engine manual.

## LUBRICATION

Use only high quality detergent oil rated with API service classification SG–SL. Select the oil's SAE viscosity grade according to your expected operating temperature.

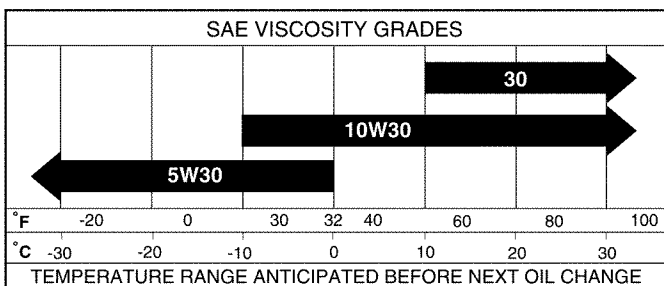

**NOTE:** Although multi-viscosity oils (5W30, 10W30 etc.) improve starting in cold weather, these multi-viscosity oils will result in increased oil consumption when used above 32°F. Check your engine oil level more frequently to avoid possible engine damage from running low on oil.

Change the oil after every 25 hours of operation or at least once a year if the snow thrower is not used for 25 hours in one year.

Check the crankcase oil level before starting the engine and after each five (5) hours of continuous use. Tighten oil fill cap / dipstick securely each time you check the oil level.

## TO CHANGE ENGINE OIL

Determine temperature range anticipated before next oil change. All oil must meet API service classification SG–SL.

- Be sure snow thrower is on level surface.
- Oil will drain more freely when warm.
- Catch oil in a suitable container.

**NOTE:** The left side wheel may be removed from snow thrower for easier access to the oil drain plug and placement of a suitable container. The unit tilted, resting on the frame with the left wheel removed, will help drain any oil trapped inside the engine. (See "TO REMOVE WHEELS" in the Service and Adjustments section of this manual).

1. Remove safety ignition key and disconnect spark plug wire from spark plug and place wire where it cannot come in contact with plug.
2. Clean area around drain plug.
3. Remove drain plug and drain oil in a suitable container.
4. Install drain plug and tighten securely.
5. Wipe off any spilled oil from snow thrower and engine.
6. Install left wheel (if removed for draining oil). Be sure to install wheel pin and retainer pin into proper hole in wheel axle (See "TO REMOVE WHEELS" in the Service and Adjustments section of this manual).
7. Remove oil fill cap/dipstick. Be careful not to allow dirt to enter the engine.
8. Refill engine with oil through oil dipstick tube. Pour slowly. Do not overfill. For approximate capacity see "PRODUCT SPECIFICATIONS" section of this manual.
9. Use gauge on oil fill cap/dipstick for checking level. Be sure dipstick cap is tightened securely for accurate reading. Keep oil at "FULL" line on dipstick.
10. Wipe off any spilled oil.

## MUFFLER

Inspect and replace corroded muffler as it could create a fire hazard and/or damage.

## SPARK PLUG

Replace spark plug at the beginning of each season or after every 100 hours of operation, whichever occurs first. Spark plug type and gap setting are shown in the "PRODUCT SPECIFICATIONS" section of this manual.

## CLEANING

**IMPORTANT:** For best performance, keep snow thrower housing free of any dirt or trash. Clean the outside of your snow thrower after each use.



**WARNING: Remove safety ignition key and disconnect spark plug wire from spark plug. Place wire where it cannot come in contact with spark plug.**

- Keep finished surfaces/wheels free of gasoline, oil, etc.
- We do not recommend using a garden hose to clean your snow thrower unless the electrical system, muffler and carburetor are covered to keep water out. Water in engine can result in shortened engine life..

# SERVICE AND ADJUSTMENTS

**WARNING: To avoid serious injury, before performing any service or adjustments:**



1. Be sure the on/off switch is in the OFF position.
2. Remove safety ignition key.
3. Make sure the augers and all moving parts have completely stopped.
4. Disconnect spark plug wire from spark plug and place wire where it cannot come in contact with plug.

## SNOW THROWER

### TO ADJUST SNOW THROWER HEIGHT

See "TO ADJUST SKID PLATES" and "SCRAPER BAR" in the Operation section of this manual.

### CHUTE DEFLECTOR

The chute deflector, attached to the top of the discharge chute, is provided to direct discharging snow away from the operator. If the deflector becomes damaged, it should be replaced.



**WARNING: To avoid serious injury, never operate your snow thrower with the deflector removed or damaged.**

- To change direction and/or distance snow is discharged, see "TO CONTROL SNOW DISCHARGE" in the Operation section of this manual.

### SHEAR BOLTS (See Fig. 18)

#### AUGER SHEAR BOLTS

Both right and left-hand augers are secured to the auger shaft with a shear bolt and hex nut. Should a foreign object or ice become lodged in the augers, the shear bolts are designed to break, preventing damage to any other components. If one or both augers do not turn when auger control lever is engaged, check to see if one or both of the bolts have sheared. To replace the shear bolts:

1. Disengage all controls and move throttle control to STOP position. Wait for all moving parts to stop.
2. Remove safety ignition key and disconnect spark plug wire from spark plug. Place wire where it cannot come in contact with spark plug.
3. Align hole in auger hub with hole in auger shaft and install a new 1/4-20 x 2" shear bolt. Install 1/4-20 lock nut and tighten securely.

**CAUTION: Do not substitute. Use only original equipment shear bolts as supplied with your snow thrower.**

4. Insert safety ignition key and reconnect spark plug wire to spark plug.

#### IMPELLER SHEAR BOLTS

The impeller is secured to the impeller shaft with two (2) capscrew/shear bolts and hex nuts. Should a foreign object or ice become lodged in the impeller, the capscrews are designed to break, preventing damage to any other components. If impeller does not turn when auger control lever is engaged, check to see if the capscrews have sheared.

To replace the capscrew/shear bolts:

1. Disengage all controls and move throttle control to STOP position. Wait for all moving parts to stop.
2. Remove safety ignition key and disconnect spark plug wire from spark plug. Place wire where it cannot come in contact with spark plug.
3. Align holes in impeller hub with holes in impeller shaft and install two (2) new 1/4-20 x 1-5/8" capscrew/shear bolts. Install 1/4-20 locknuts and tighten securely.

**CAUTION: Do not substitute. Use only original equipment capscrew/shear bolts as supplied with your snow thrower.**

4. Insert safety ignition key and reconnect spark plug wire to spark plug.

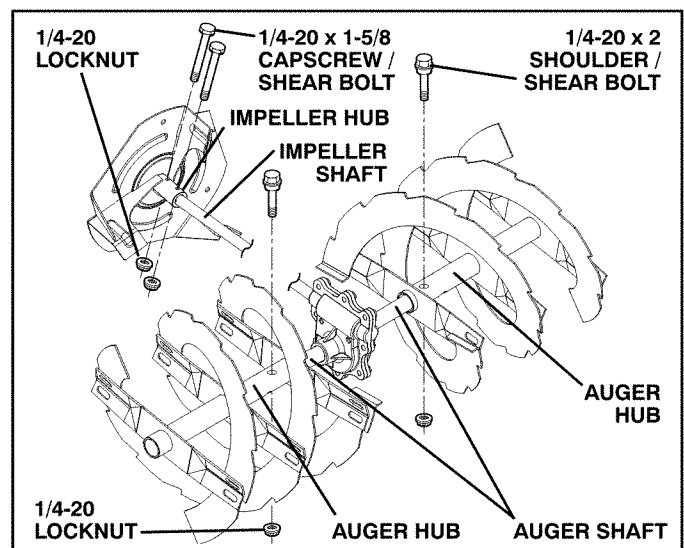

FIG. 18

### TO REMOVE BELT COVER (See Fig. 19)

1. Loosen the two (2) screws securing belt cover to frame.
  2. Remove belt cover.
- Replace belt cover by installing cover and tightening screws.

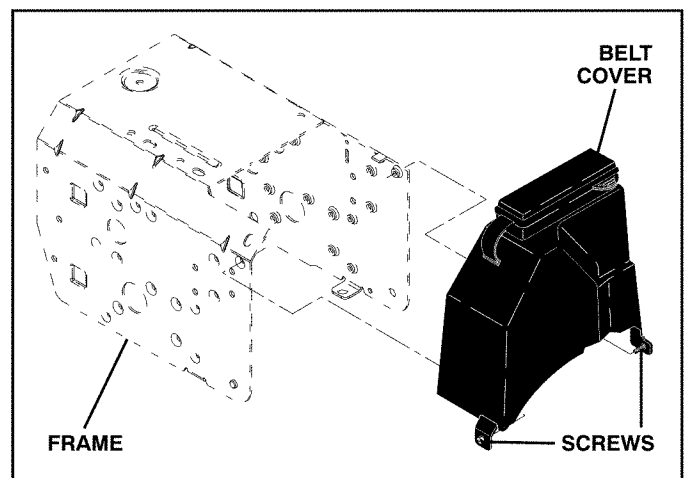

FIG. 19

# SERVICE AND ADJUSTMENTS

## TO REPLACE BELTS (See Fig. 20)

The auger and traction drive belts are not adjustable. If the belts are damaged or begin to slip from wear, they should be replaced. It is recommended that the belt(s) be replaced by a service center/department.

**NOTE:** It is recommended that both the auger and traction drive belt be replaced at the same time.

The V-belts on your snow thrower are of special construction and should be replaced by original equipment manufacturer (OEM) belts available from your nearest service center/department. Using other than OEM belts can cause personal injury or damage to the snow thrower.

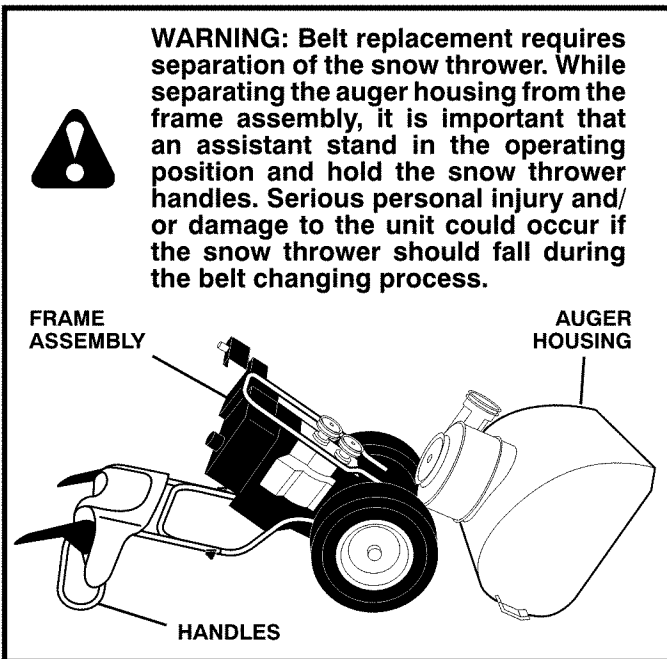

1. REMOVE GASOLINE FROM FUEL TANK - Drain gasoline from fuel tank into a suitable container, outdoors, away from fire or flame. Wipe up any spilled gasoline.
2. REMOVE DISCHARGE CHUTE - Loosen locknut securing chute rotator head to mounting bracket only enough to allow chute rotator head to be raised and discharge chute to be removed from snow thrower.
3. REMOVE BELT COVER - See "TO REMOVE BELT COVER" in this section of this manual.
4. REMOVE ENGINE PULLEY - Remove bolt, flat washer securing pulley to engine crankshaft. Remove outside (auger) pulley only from crankshaft.
5. SEPARATE SNOW THROWER - With your assistant standing in the operating position holding the handles, remove the two (2) bolts holding the auger housing and frame together.

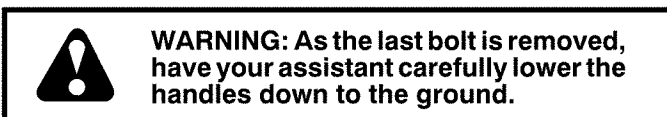

6. REMOVE HAIRPIN FROM CLUTCH ROD and remove clutch rod from swing plate. Tip swing plate forward.
7. REMOVE AUGER BELT from around pulley.

8. RELIEVE TENSION ON TRACTION DRIVE BELT IDLER and remove traction drive belt from around pulleys.

**HINT:** Insert a 3/8" drive ratchet (in the "ON" position) into the square hole in idler arm and rotate ratchet clockwise to relieve tension.

9. With tension relieved on idler, install new traction drive belt around pulleys and inside belt keepers.
10. Install clutch rod in swing plate; secure with hairpin.
11. Place auger belt around and inside the groove of auger pulley only.
12. While your assistant slowly raises handles to rejoin the auger housing and frame assembly, pull up on the auger belt and squeeze sides together above pulley so belt is fully seated in groove of pulley.
13. Move idler arm so it does not hit impeller pulley as you bring snow thrower completely together and check carefully for proper routing of belts. If auger belt has become dislodged from the pulley (by catching the idler arm bracket while bringing snow thrower together), separate the snow thrower and repeat step 12. Belt must be fully seated in pulley groove when bringing the snow thrower together.
14. Install the two (2) hex bolts and tighten securely.
15. INSTALL ENGINE PULLEY - Place belt in pulley groove and slide pulley on crankshaft. Install flat washer, bolt and tighten securely (41-47 N-m torque). Make sure belt is inside belt keeper.
16. INSTALL BELT COVER and two (2) screws. Tighten securely.
17. INSTALL DISCHARGE CHUTE - See "INSTALL DISCHARGE CHUTE / CHUTE ROTATER HEAD" in the Assembly / Pre-Operation section of this manual.

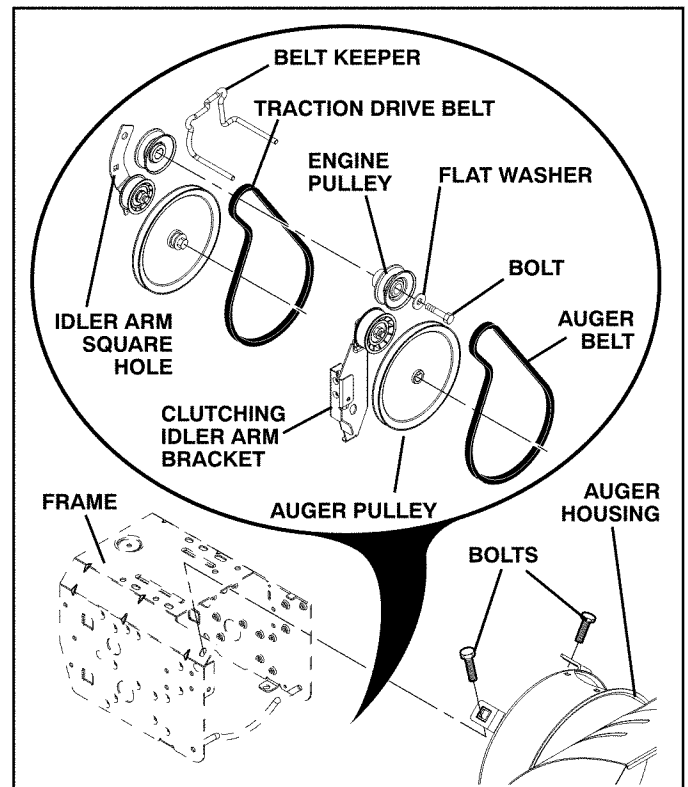

FIG. 20



# SERVICE AND ADJUSTMENTS

## TO REMOVE WHEELS (See Fig. 21)

- Remove the wheel pin and retainer pin and remove wheel from axle.

**IMPORTANT:** When installing wheel, be sure to use the inner most hole in axle and the wheel hub hole. To disengage drive system from the wheels (for pushing or transporting the snow thrower) remove wheel pin and retainer pin from wheel hub and insert wheel pin and retainer into the outer hole in axle only.

**NOTE:** To seal punctures or prevent flat tires due to slow leaks, tire sealant may be purchased from your local parts dealer. Tire sealant also prevents tire dry rot and corrosion.

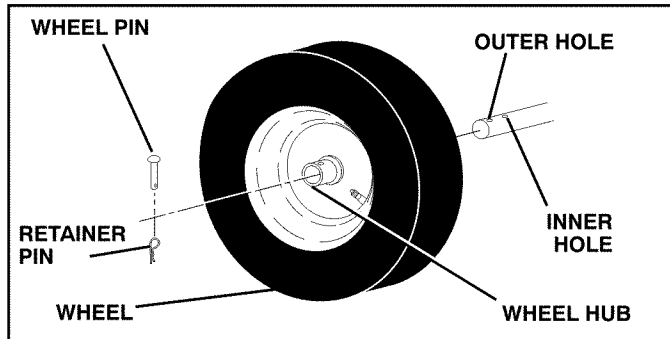

FIG. 21

## TO ADJUST CABLE TENSION (See Fig. 22)

Adjust cable tension by turning the adjuster turn buckle, located on the right hand cable. Grasp the long section tightly and turn the short section to lengthen the adjuster. Adjust until cable is snug.

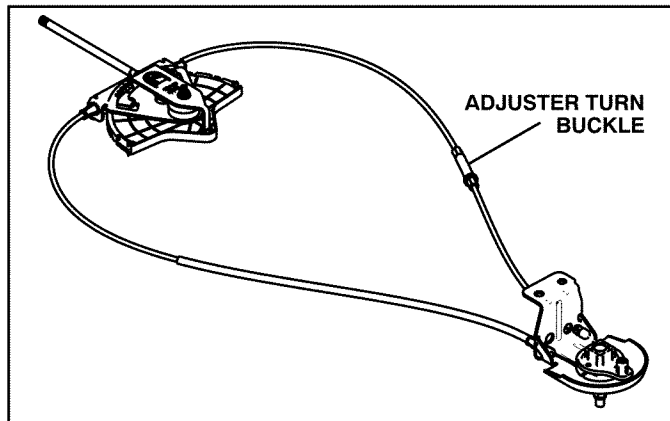

FIG. 22

## TO ADJUST TRACTION BELT AND AUGER BELT TENSION

If the traction or auger belt is slipping because it is not tight enough when engaged, the tension can be increased by adjusting the spring location in the control rod. Unhook the rod from the control lever and move the spring at the bottom of the rod one or two holes closer to the top of the rod. This effectively shortens the rod and increases the belt tension. (See "INSTALL AUGER CONTROL ROD" in the Assembly section of this manual.)

## ENGINE

See engine manual.

## CARBURETOR

Your carburetor is not adjustable. Engine performance should not be affected at altitudes up to 7,000 feet (2,134 meters). If your engine does not operate properly due to suspected carburetor problems, take your snow thrower to a qualified service center.

## ENGINE SPEED

Never tamper with the engine governor, which is factory set for proper engine speed. Overspeeding the engine above the factory high speed setting can be dangerous and will void the warranty. If you think the engine-governed high speed needs adjusting, contact a qualified service center, which has proper equipment and experience to make any necessary adjustments.

# STORAGE

Immediately prepare your snow thrower for storage at the end of the season or if the unit will not be used for 30 days or more.



**WARNING: Never store the snow thrower with gasoline in the tank inside a building where fumes may reach an open flame, spark or pilot light as on a furnace, water heater, clothes dryer or gas appliance. Allow the engine to cool before storing in any enclosure.**

## SNOW THROWER

When snow thrower is to be stored for a period of time, clean it thoroughly, remove all dirt, grease, leaves, etc. Store in a clean, dry area.

1. Clean entire snow thrower (See "CLEANING" in the Maintenance section of this manual).
2. Inspect and replace belts, if necessary (See "TO REPLACE BELTS" in the Service and Adjustments section of this manual).
3. Lubricate as shown in the Maintenance section of this manual.
4. Be sure that all nuts, bolts, screws, and pins are securely fastened. Inspect moving parts for damage, breakage and wear. Replace if necessary.
5. Touch up all rusted or chipped paint surfaces; sand lightly before painting.

## ENGINE

See engine manual.

## FUEL SYSTEM

**IMPORTANT:** It is important to prevent gum deposits from forming in essential fuel system parts such as carburetor, fuel hose, or tank during storage. Also, alcohol blended fuels (called gasohol or using ethanol or methanol) can attract moisture which leads to separation and formation of acids during storage. Acidic gas can damage the fuel system of an engine while in storage.

- Empty the fuel tank by starting the engine and letting it run until the fuel lines and carburetor are empty.
- Never use engine or carburetor cleaner products in the fuel tank or permanent damage may occur.
- Use fresh fuel next season.

**NOTE:** Fuel stabilizer is an acceptable alternative in minimizing the formation of fuel gum deposits during storage. Add stabilizer to gasoline in fuel tank or storage container. Always follow the mix ratio found on stabilizer container. Run engine at least 10 minutes after adding stabilizer to allow the stabilizer to reach the carburetor. Do not empty the gas tank and carburetor if using fuel stabilizer.

## ENGINE OIL

Drain oil (with engine warm) and replace with clean engine oil. (See "ENGINE" in the Maintenance section of this manual).

## CYLINDER

1. Remove spark plug.
2. Pour one ounce (29 ml) of oil through spark plug hole into cylinder.
3. Pull recoil starter handle slowly a few times to distribute oil.
4. Replace with new spark plug.

## OTHER

- Remove safety ignition key; store it in a safe place.
- Do not store gasoline from one season to another.
- Replace your gasoline can if your can starts to rust. Rust and/or dirt in your gasoline will cause problems.
- If possible, store your snow thrower indoors and cover it to protect it from dust and dirt.
- Cover your snow thrower with a suitable protective cover that does not retain moisture. Do not use plastic. Plastic cannot breathe, which allows condensation to form and will cause your snow thrower to rust.

**IMPORTANT:** Never cover snow thrower while engine/exhaust area is still warm.

# TROUBLESHOOTING

See appropriate section in manual unless directed to an authorized service center/department.

PROBLEM	CAUSE	CORRECTION
<b>Does not start</b>	<ol style="list-style-type: none"> <li>1. Fuel shut-off valve (if so equipped) in OFF position.</li> <li>2. Safety ignition key is not inserted.</li> <li>3. Out of fuel.</li> <li>4. Throttle in STOP position (or ON/OFF switch is OFF).</li> <li>5. Choke in OFF position.</li> <li>6. Primer not depressed.</li> <li>7. Engine is flooded.</li> <li>8. Spark plug wire is disconnected.</li> <li>9. Bad spark plug.</li> <li>10. Stale fuel.</li> <li>11. Water in fuel.</li> </ol>	<ol style="list-style-type: none"> <li>1. Turn fuel shut-off valve to OPEN position.</li> <li>2. Insert safety ignition key.</li> <li>3. Fill fuel tank with fresh, clean gasoline.</li> <li>4. Move throttle to FAST position (or ON/OFF switch to ON position).</li> <li>5. Move to FULL position.</li> <li>6. Prime as instructed in the Operation section of this manual.</li> <li>7. Wait a few minutes before restarting, DO NOT prime.</li> <li>8. Connect wire to spark plug.</li> <li>9. Replace spark plug.</li> <li>10. Empty fuel tank &amp; carburetor, refill with fresh, clean gasoline.</li> <li>11. Empty fuel tank &amp; carburetor, refill with fresh, clean gasoline.</li> </ol>
<b>Loss of power</b>	<ol style="list-style-type: none"> <li>1. Spark plug wire loose.</li> <li>2. Throwing too much snow.</li> <li>3. Fuel tank cap is covered with ice or snow.</li> <li>4. Dirty or clogged muffler.</li> </ol>	<ol style="list-style-type: none"> <li>1. Reconnect spark plug wire.</li> <li>2. Reduce speed and width of swath.</li> <li>3. Remove ice and snow on and around fuel tank cap.</li> <li>4. Clean or replace muffler.</li> </ol>
<b>Engine idles or runs roughly</b>	<ol style="list-style-type: none"> <li>1. Choke is in FULL position.</li> <li>2. Blockage in fuel line.</li> <li>3. Stale fuel.</li> <li>4. Water in fuel.</li> <li>5. Carburetor is in need of adjustment or overhaul.</li> </ol>	<ol style="list-style-type: none"> <li>1. Move choke to OFF position.</li> <li>2. Clean fuel line.</li> <li>3. Empty fuel tank &amp; carburetor, refill with fresh, clean gasoline.</li> <li>4. Empty fuel tank &amp; carburetor, refill with fresh, clean gasoline.</li> <li>5. Contact an authorized service center/department.</li> </ol>
<b>Excessive vibration</b>	<ol style="list-style-type: none"> <li>1. Loose parts or damaged augers or impeller.</li> </ol>	<ol style="list-style-type: none"> <li>1. Tighten all fasteners. Replace damaged parts. If vibration remains, contact an authorized service center/department.</li> </ol>
<b>Recoil starter is hard to pull</b>	<ol style="list-style-type: none"> <li>1. Frozen recoil starter.</li> </ol>	<ol style="list-style-type: none"> <li>1. See "IF RECOIL STARTER HAS FROZEN" in the Operation section of this manual.</li> </ol>
<b>Loss of traction drive / slowing of drive speed</b>	<ol style="list-style-type: none"> <li>1. Drive belt is worn.</li> <li>2. Drive belt is off of pulley.</li> <li>3. Friction drive wheel is worn.</li> </ol>	<ol style="list-style-type: none"> <li>1. Check / replace drive belt.</li> <li>2. Check / reinstall drive belt.</li> <li>3. Contact an authorized service center/department.</li> </ol>
<b>Loss of snow discharge or slowing of snow discharge</b>	<ol style="list-style-type: none"> <li>1. Auger belt is off of pulley.</li> <li>2. Auger belt is worn.</li> <li>3. Clogged discharge chute.</li> <li>4. Augers / impeller jammed.</li> </ol>	<ol style="list-style-type: none"> <li>1. Check / reinstall auger belt.</li> <li>2. Check / replace auger belt.</li> <li>3. Clean snow chute.</li> <li>4. Remove debris or foreign object from augers / impeller.</li> </ol>

**REPAIR PARTS SNOW THROWER - - MODEL NUMBER PR624ES (96192003703)  
 AUGER HOUSING / IMPELLER ASSEMBLY**

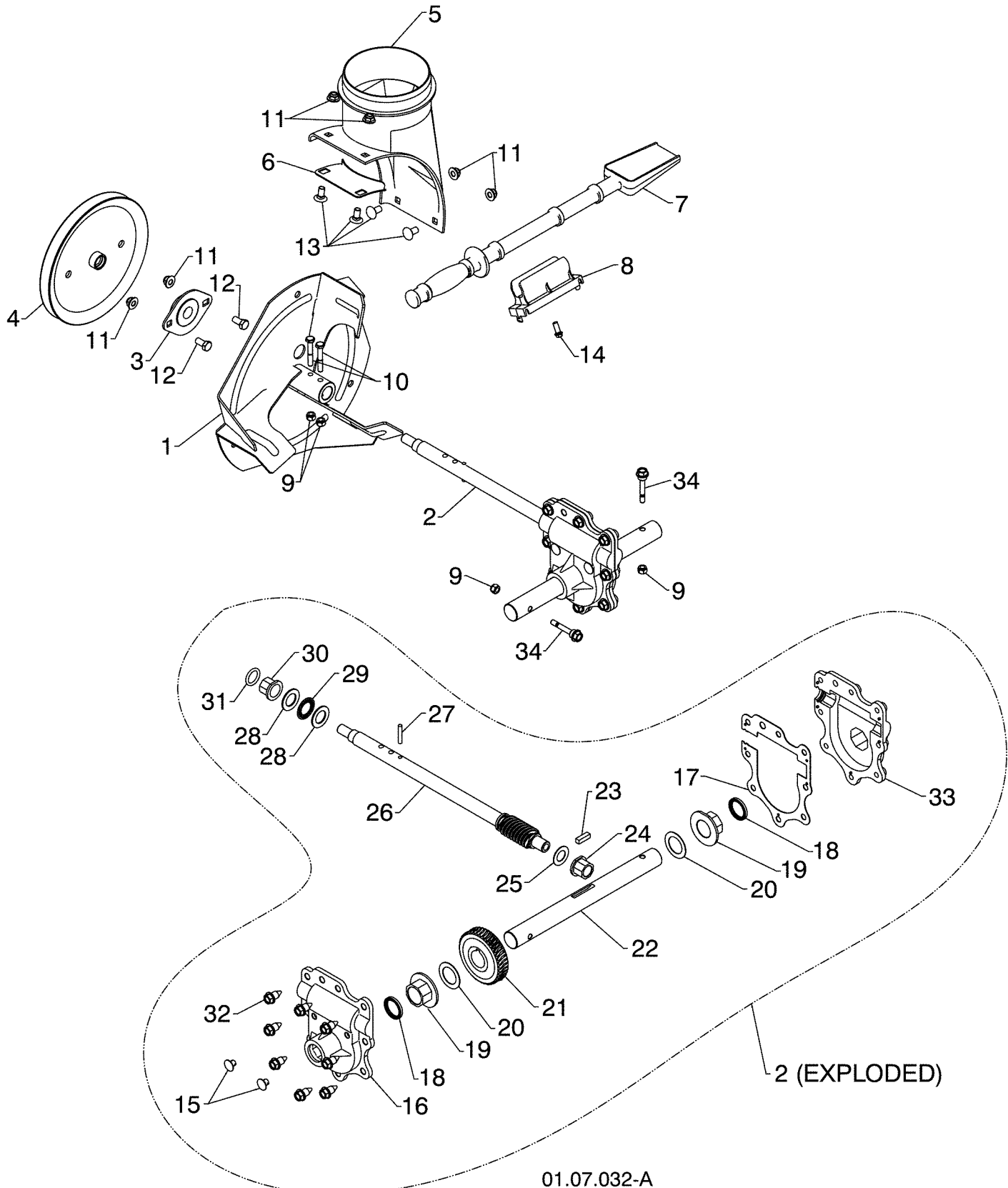

01.07.032-A

**NOTE:** All component dimensions given in U.S. inches. 1 inch = 25.4 mm  
**IMPORTANT:** Use only Original Equipment Manufacturer (O.E.M.) replacement parts.  
 Failure to do so could be hazardous, damage your snow thrower and void your warranty.

# REPAIR PARTS SNOW THROWER - - MODEL NUMBER PR624ES (96192003703)

## AUGER HOUSING / IMPELLER ASSEMBLY

KEY NO.	PART NO.	DESCRIPTION
1	532 18 41-05	IMPELLER
2	584 64 83-01	GEARBOX ASSEMBLY
3	532 18 89-09	BEARING
4	585 09 32-01	IMPELLER PULLEY
5	532 44 24-38	DISCHARGE BASE
6	532 18 40-95	CORNER BRACKET
7	532 19 21-99	CLEAN OUT TOOL
8	532 40 54-00	TOOL CLIP
9	873 80 04-00	NUT 1/4-20
10	874 78 04-26	SCREW 1/4-20 X .625
11	532 42 79-42	NUT 5/16-18
12	532 16 31-83	SCREW 5/16-18 X .625
13	532 18 03-55	CARRIAGE BOLT
14	532 19 41-89	SCREW 13-16 X .625
15	532 40 77-60	PLUG
16	532 42 73-02	GEARBOX COVER RH
17	532 42 73-45	GASKET
18	532 40 77-70	SEAL
19	532 40 77-62	BEARING
20	532 17 46-97	THRUST WASHER 1.00
21	580 36 41-01	WORM GEAR
22	532 40 77-64	AUGER SHAFT
23	532 18 92-82	SQUARE KEY
24	532 40 77-58	BEARING
25	532 17 46-83	THRUST WASHER
26	584 64 84-01	IMPELLER SHAFT
27	532 18 42-05	ROLL PIN
28	532 17 46-81	THRUST WASHER
29	532 17 46-84	THRUST BEARING
30	532 40 77-69	BEARING
31	532 40 77-68	O-RING
32	532 40 77-67	SCREW 5/16-18 X .750
33	532 42 73-17	GEARBOX COVER LH
34	532 19 20-90	SHEAR BOLT

**NOTE:** All component dimensions given in U.S. inches. 1 inch = 25.4 mm  
**IMPORTANT:** Use only Original Equipment Manufacturer (O.E.M.) replacement parts.  
 Failure to do so could be hazardous, damage your snow thrower and void your warranty.

**REPAIR PARTS SNOW THROWER - - MODEL NUMBER PR624ES (96192003703)**  
**AUGER HOUSING / IMPELLER ASSEMBLY**

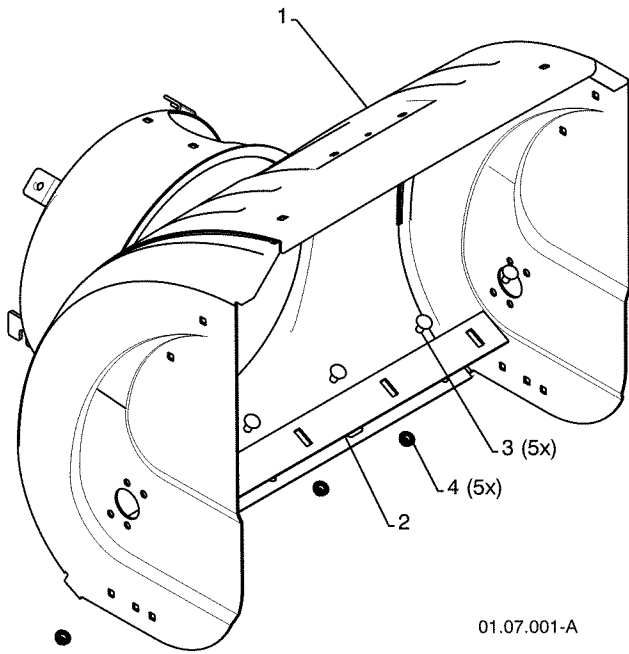

KEY NO.	PART NO.	DESCRIPTION
1	532 43 88-28	AUGER HOUSING
2	532 40 78-25	SCRAPPER BAR
3	872 27 05-05	CARRIAGE BOLT 5/16-18 X .625
4	532 15 53-77	NUT 5/16-18

01.07.001-A

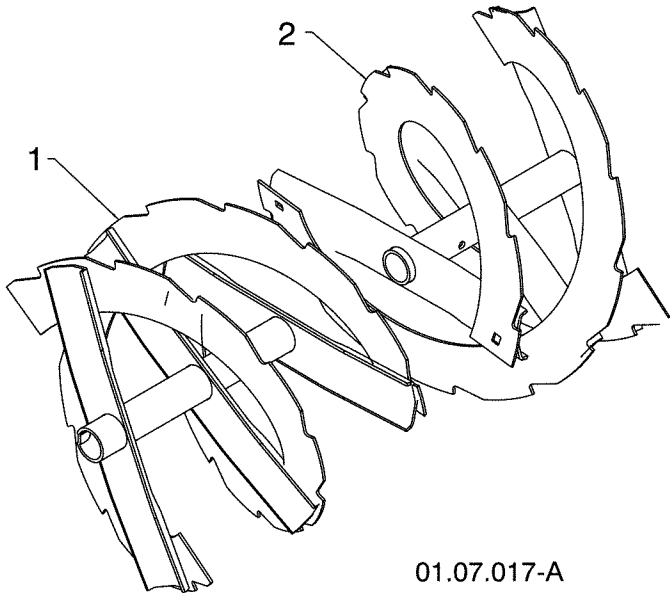

KEY NO.	PART NO.	DESCRIPTION
1	532 42 10-72	AUGER ASSEMBLY LH 24
2	532 42 10-73	AUGER ASSEMBLY RH 24

01.07.017-A

**NOTE:** All component dimensions given in U.S. inches. 1 inch = 25.4 mm  
**IMPORTANT:** Use only Original Equipment Manufacturer (O.E.M.) replacement parts.  
 Failure to do so could be hazardous, damage your snow thrower and void your warranty.

**REPAIR PARTS SNOW THROWER - - MODEL NUMBER PR624ES (96192003703)  
AUGER HOUSING / IMPELLER ASSEMBLY**

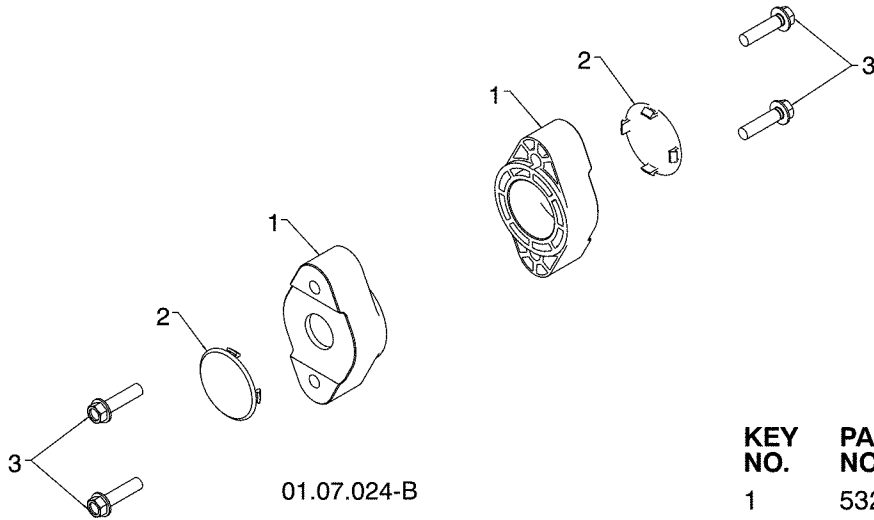

01.07.024-B

KEY NO.	PART NO.	DESCRIPTION
1	532 42 04-78	AUGER BEARING
2	532 41 19-39	BEARING PLUG
3	532 17 95-82	SCREW 5/16-18 X 1.00

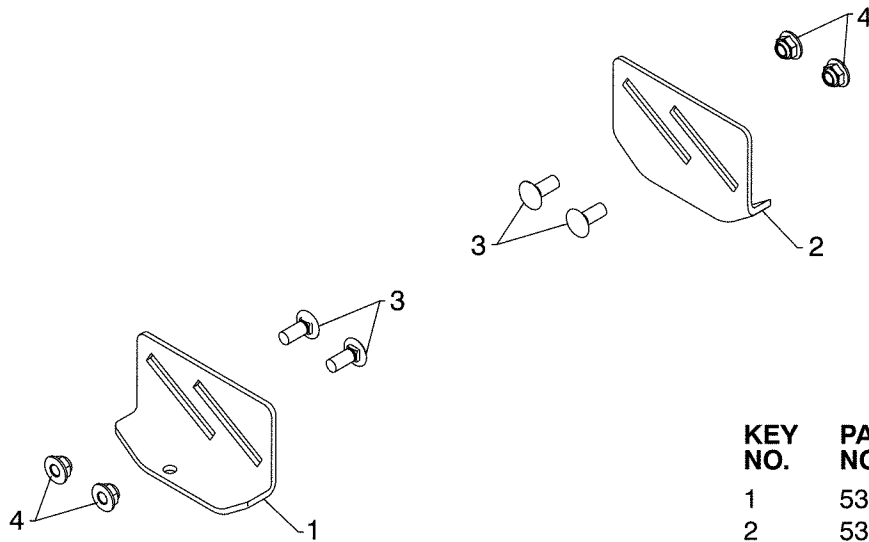

01.11.001-C

KEY NO.	PART NO.	DESCRIPTION
1	532 18 40-93	SKID PLATE LH
2	532 18 40-94	SKID PLATE RH
3	872 27 05-06	CARRIAGE BOLT 5/16-18 X .75
4	532 42 79-42	NUT 5/16-18

**NOTE:** All component dimensions given in U.S. inches. 1 inch = 25.4 mm  
**IMPORTANT:** Use only Original Equipment Manufacturer (O.E.M.) replacement parts.  
Failure to do so could be hazardous, damage your snow thrower and void your warranty.

# REPAIR PARTS SNOW THROWER - - MODEL NUMBER PR624ES (96192003703)

## CONTROL PANEL / CHUTE

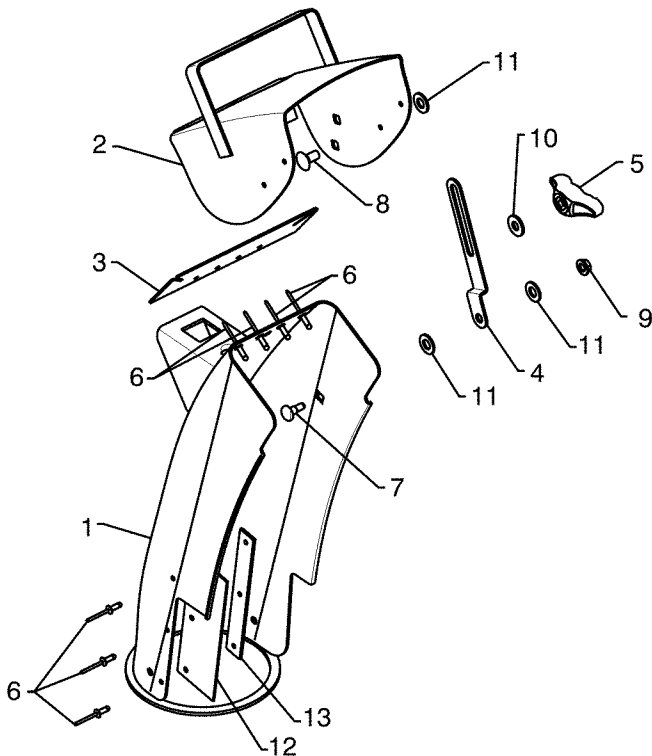

01.09.005-E

KEY NO.	PART NO.	DESCRIPTION
1	532 44 42-39	CHUTE WELDMENT
2	532 43 88-32	DEFLECTOR WELDMENT
3	532 42 03-25	DEFLECTOR SEAL
4	532 18 41-14	STRAP
5	532 19 19-38	KNOB BLACK
6	532 12 84-15	POP RIVET
7	532 18 56-00	SHOULDER BOLT 1/4-20 X .704
8	872 27 05-05	CARRIAGE BOLT 5/16-18 X .625
9	532 19 17-30	NUT 1/4-20
10	532 15 54-15	WASHER
11	532 17 92-46	PLASTIC WASHER
12	532 43 03-24	CHUTE SNOW SHIELD
13	532 42 17-28	SHIELD RETAINER STRAP

**NOTE:** All component dimensions given in U.S. inches. 1 inch = 25.4 mm  
**IMPORTANT:** Use only Original Equipment Manufacturer (O.E.M.) replacement parts.  
 Failure to do so could be hazardous, damage your snow thrower and void your warranty.



**REPAIR PARTS SNOW THROWER - - MODEL NUMBER PR624ES (96192003703)  
CONTROL PANEL / CHUTE**

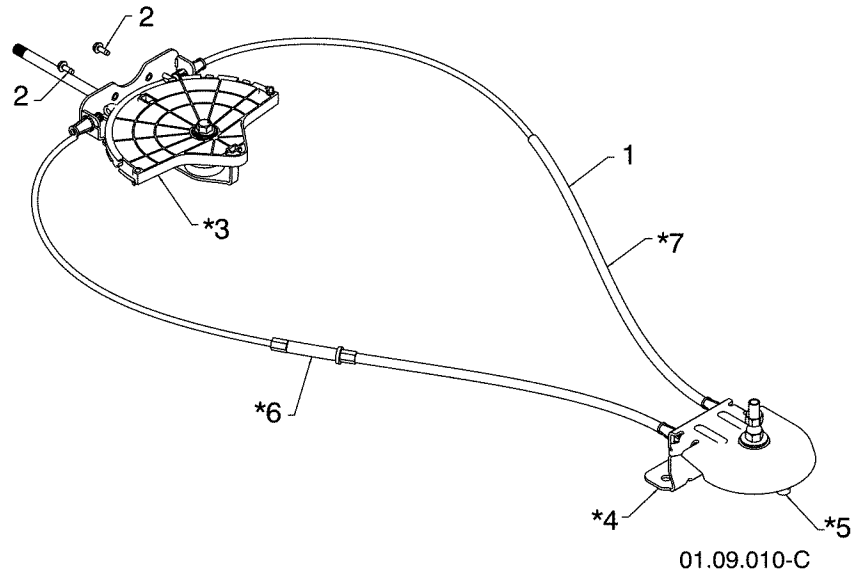

KEY NO.	PART NO.	DESCRIPTION
1	532 42 82-72	LEVER/CABLE ROTATOR ASSEMBLY
2	817 54 10-08	SCREW 10-24 X .625
*3	532 42 06-78	ROTATOR HEAD
*4	532 40 59-32	ROTATOR PIVOT BRACKET
*5	532 42 06-75	PULLEY PIVOT
*6	532 42 82-73	CABLE ASSEMBLY ADJUSTABLE
*7	532 42 83-10	CABLE ASSEMBLY HEAT SHIELD

**NOTES:**

1. ITEMS INDICATED WITH AN \* ARE LISTED AS REFERENCE FOR SERVICE PARTS ONLY.

**NOTE:** All component dimensions given in U.S. inches. 1 inch = 25.4 mm  
**IMPORTANT:** Use only Original Equipment Manufacturer (O.E.M.) replacement parts.  
 Failure to do so could be hazardous, damage your snow thrower and void your warranty.

# REPAIR PARTS SNOW THROWER - - MODEL NUMBER PR624ES (96192003703) HANDLES

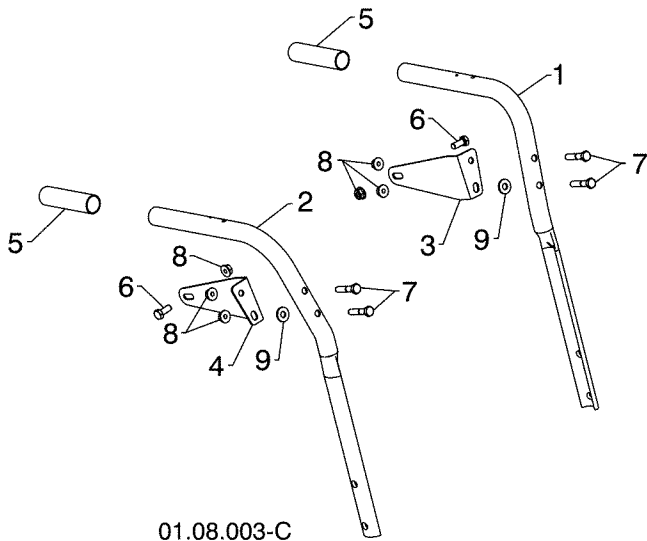

KEY NO.	PART NO.	DESCRIPTION
1	532 42 10-69	PLOW HANDLE LH
2	532 42 10-70	PLOW HANDLE RH
3	532 42 91-48	PANEL BRACKET LH
4	532 42 91-49	PANEL BRACKET RH
5	532 19 95-13	HANDLE GRIP
6	874 78 05-12	SCREW 5/16-18 X .750
7	874 78 05-24	SCREW 5/16-18 X 1.50
8	532 75 11-53	NUT 5/16-18
9	532 15 54-15	WASHER

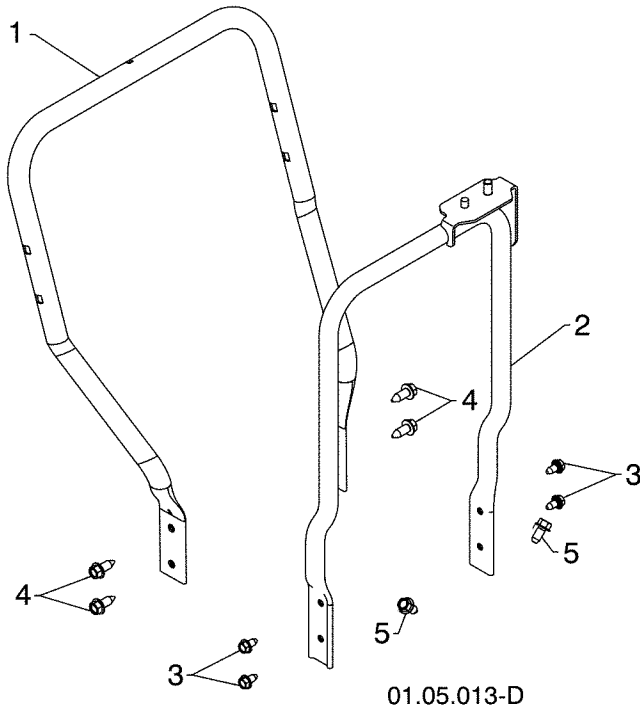

KEY NO.	PART NO.	DESCRIPTION
1	585 23 81-02	LOWER HANDLE
2	532 44 36-17	PIVOT SUPPORT WELDMENT
3	817 00 05-10	SCREW 5/16-18 X .750
4	817 00 06-16	SCREW 3/8-16 X 1.00
5	817 00 06-12	SCREW 3/8-16 X .750

**NOTE:** All component dimensions given in U.S. inches. 1 inch = 25.4 mm  
**IMPORTANT:** Use only Original Equipment Manufacturer (O.E.M.) replacement parts.  
 Failure to do so could be hazardous, damage your snow thrower and void your warranty.

# REPAIR PARTS SNOW THROWER - - MODEL NUMBER PR624ES (96192003703) HANDLES

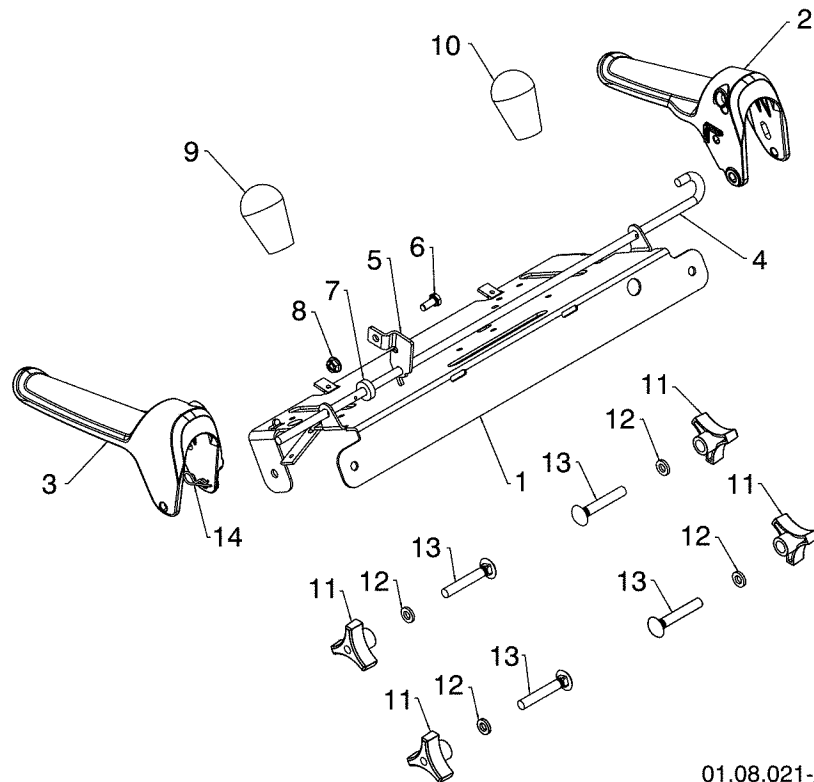

01.08.021-A

KEY NO.	PART NO.	DESCRIPTION
1	585 19 88-02	CONTROL PANEL
2	581 77 98-01	LH CONTROL LEVER
3	581 77 97-01	RH CONTROL LEVER
4	584 80 90-01	INTERLOCK CONTROL ROD
5	585 00 47-03	INTERLOCK BRACKET
6	874 78 04-10	1/4-20 X .625 HEX HEAD SCREW
7	532 42 16-13	SPACER
8	532 08 83-49	1/4-20 FLANGE NUT (TOP LOCK)
9	532 41 42-81	KNOB RED
10	532 41 42-80	KNOB BLACK
11	532 17 88-99	HANDLE KNOB
12	819 13 13-16	3/8 WASHER
13	872 12 06-18	CARRIAGE BOLT 3/8-16 X 2.25
14	532 16 96-75	RETAINER

**NOTE:** All component dimensions given in U.S. inches. 1 inch = 25.4 mm  
**IMPORTANT:** Use only Original Equipment Manufacturer (O.E.M.) replacement parts.  
 Failure to do so could be hazardous, damage your snow thrower and void your warranty.

# REPAIR PARTS SNOW THROWER - - MODEL NUMBER PR624ES (96192003703) HANDLES

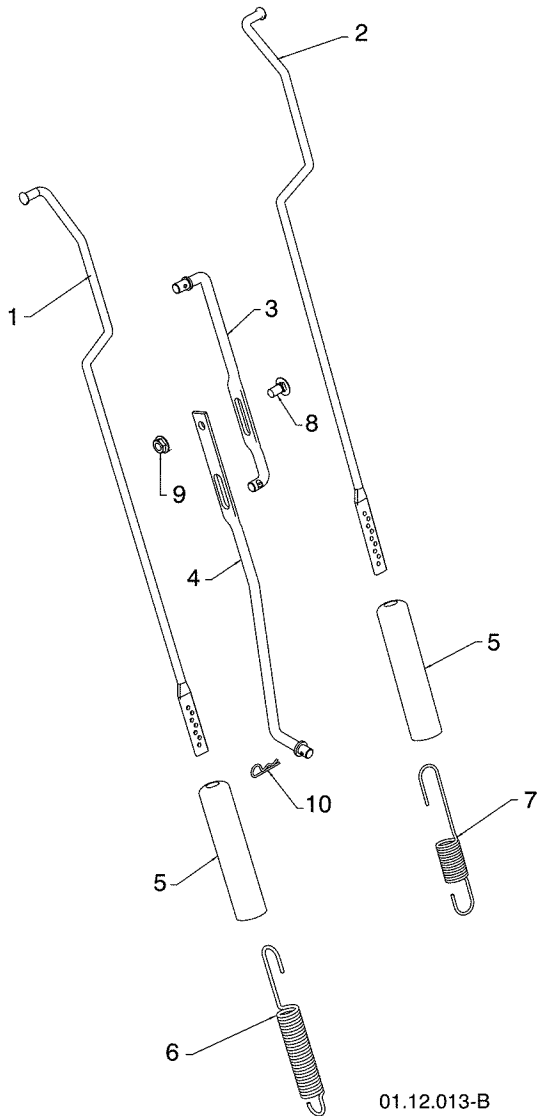

KEY NO.	PART NO.	DESCRIPTION
1	584 80 87-01	ROD IMPELLER CONTROL
2	584 80 88-01	ROD TRACTION CONTROL
3	532 18 04-45	SHIFTER ROD TOP
4	532 18 77-16	SHIFTER ROD BOTTOM
5	532 18 04-47	SPRING SLEEVE
6	580 79 62-01	SPRING CONTROL ROD
7	580 80 21-01	SPRING TRACTION ROD
8	872 27 05-05	CARRIAGE BOLT 5/16-18 X .75
9	532 15 53-77	NUT 5/16-18
10	532 16 96-75	RETAINER HAIRPIN

**NOTE:** HOOK TRACTION ROD SPRING IN HOLE 7  
HOOK IMPELLER ROD SPRING IN HOLE 4

01.12.013-B

**NOTE:** All component dimensions given in U.S. inches. 1 inch = 25.4 mm  
**IMPORTANT:** Use only Original Equipment Manufacturer (O.E.M.) replacement parts.  
Failure to do so could be hazardous, damage your snow thrower and void your warranty.

# REPAIR PARTS SNOW THROWER - - MODEL NUMBER PR624ES (96192003703) HANDLES

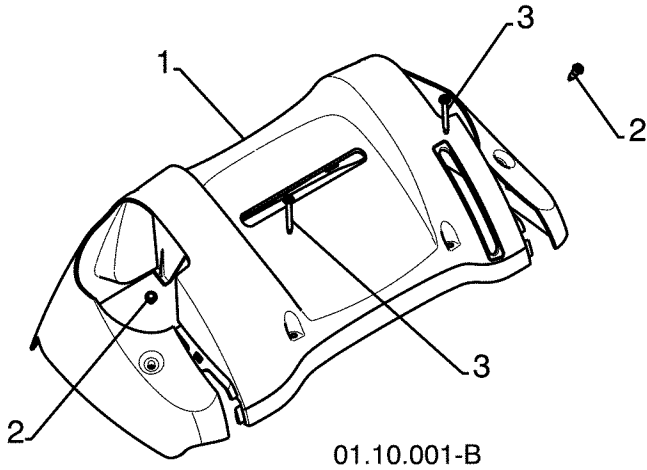

KEY NO.	PART NO.	DESCRIPTION
1	532 18 33-52	CONSOLE PANEL
2	532 18 44-71	SCREW 10-24 X .625
3	532 17 52-62	SCREW 10-24 X 1.25

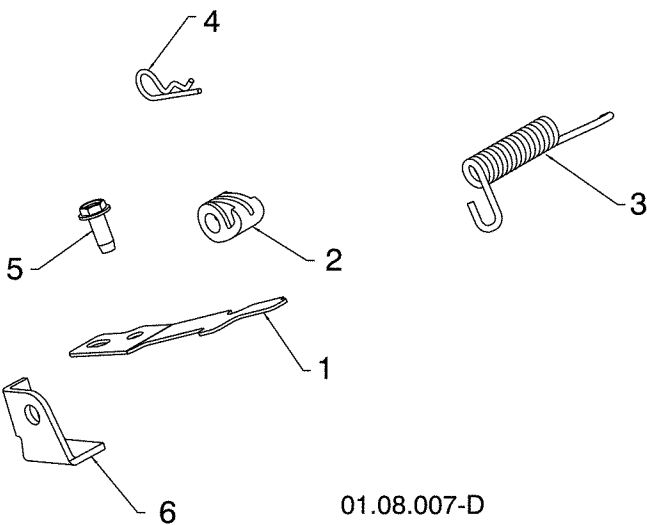

KEY NO.	PART NO.	DESCRIPTION
1	532 41 62-88	INTERLOCK SPRING
2	532 44 52-91	INTERLOCK CAM
3	532 44 32-15	TORSION SPRING
4	532 16 96-75	RETAINER
5	817 06 04-10	SCREW 1/4-20 X .625
6	532 42 18-14	INTERLOCK STOP

**NOTE:** All component dimensions given in U.S. inches. 1 inch = 25.4 mm  
**IMPORTANT:** Use only Original Equipment Manufacturer (O.E.M.) replacement parts.  
 Failure to do so could be hazardous, damage your snow thrower and void your warranty.

# REPAIR PARTS SNOW THROWER - - MODEL NUMBER PR624ES (96192003703)

## DRIVE

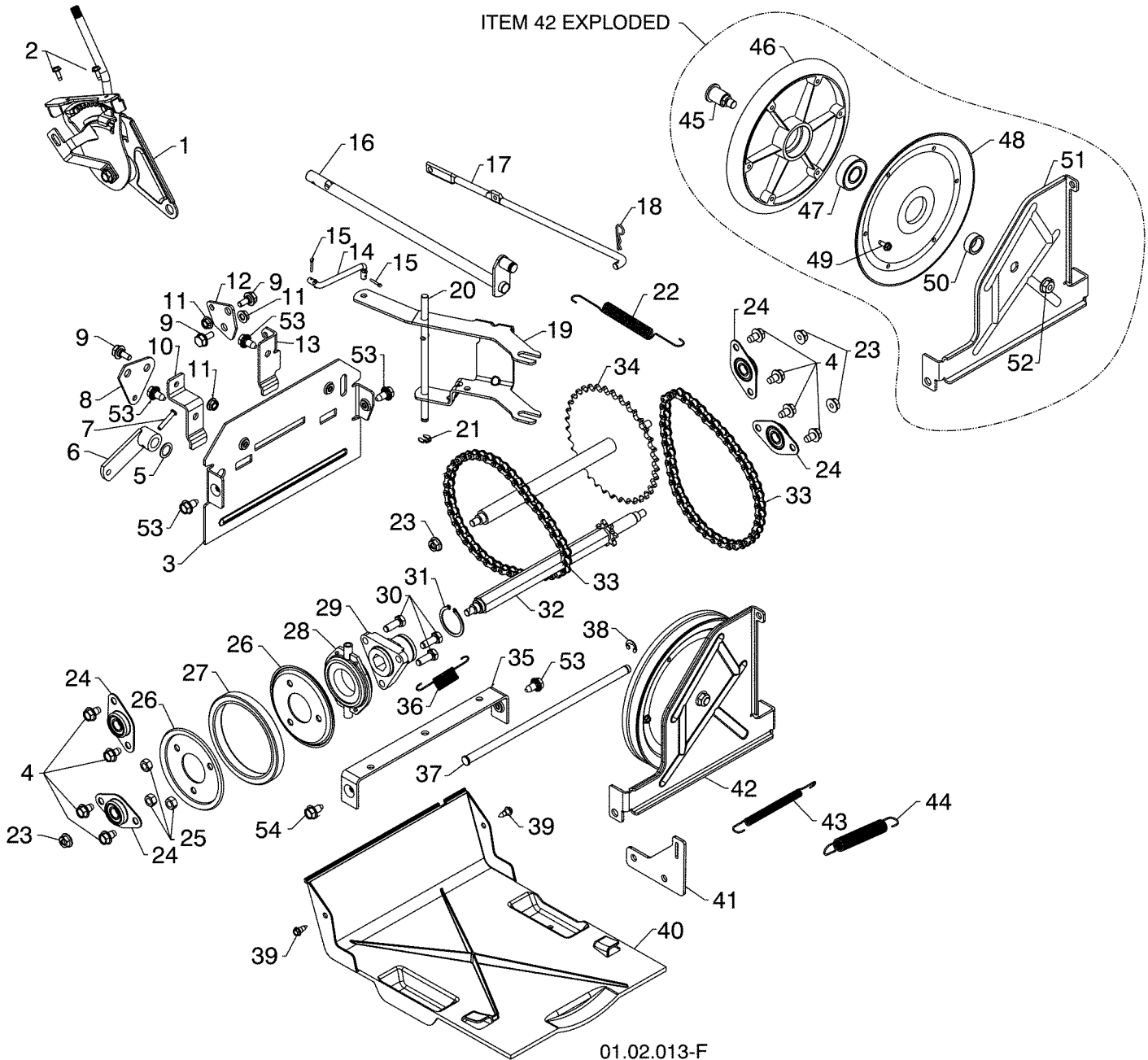

**NOTE:** All component dimensions given in U.S. inches. 1 inch = 25.4 mm  
**IMPORTANT:** Use only Original Equipment Manufacturer (O.E.M.) replacement parts.  
 Failure to do so could be hazardous, damage your snow thrower and void your warranty.

# REPAIR PARTS SNOW THROWER - - MODEL NUMBER PR624ES (96192003703) DRIVE

KEY NO.	PART NO.	DESCRIPTION	KEY NO.	PART NO.	DESCRIPTION
1	532 19 88-75	SPEED SELECTOR ASSEMBLY	28	532 17 53-44	BEARING
2	817 50 10-10	SCREW 10-24 X .625	29	532 17 86-13	WHEEL HUB
3	532 43 88-37	END PLATE	30	874 76 05-14	SCREW 5/16-18-.875
4	817 49 05-08	SCREW 5/16-18 X .50	31	812 00 00-12	RETAINER RING
5	532 05 70-79	WASHER	32	532 40 21-87	SPROCKET SHAFT
6	532 40 54-85	CONTROL ARM	33	532 40 16-19	CHAIN
7	532 19 85-80	CLEVIS PIN	34	532 43 73-03	SPROCKET WELDMENT
8	532 41 54-50	SHIFTER PLATE	35	532 41 54-29	SHIFTER BRACKET
9	532 40 28-81	SHOULDER BOLT	36	532 18 01-35	SPRING
10	532 41 54-33	SHIFTER BRACKET	37	532 40 26-52	PLATE PIVOT ROD
11	532 19 17-30	NUT 1/4-20	38	532 42 82-88	E-RING .375
12	532 41 54-35	CLUTCH PLATE	39	532 18 44-71	SHOULDER SCREW
13	532 41 68-64	CLUTCH BRACKET	40	532 41 08-77	BOTTOM PAN
14	532 18 71-01	SHIFTER LINK	41	532 41 66-82	SPRING BRACKET
15	532 70 02-79	RETAINER	42	532 40 26-89	DRIVE PLATE ASSEMBLY
16	532 42 75-42	CONTROL SHAFT	43	532 41 45-57	IDLER SPRING
17	532 40 25-68	CLUTCH ROD	44	532 17 88-28	IDLER SPRING
18	532 16 96-75	RETAINER	45	532 40 25-04	PULLEY SHAFT
19	581 42 25-01	SHIFTER YOKE	46	532 40 18-20	DRIVE PLATE
20	532 40 23-10	PIVOT ROD	47	532 19 87-91	BEARING
21	812 00 00-36	RETAINER	48	532 40 23-93	PULLEY HALF
22	532 40 28-78	RETURN SPRING	49	817 54 10-08	SCREW 10-24 X .50
23	532 75 11-53	NUT 5/16-18	50	532 40 25-11	SPACER BEARING
24	532 40 89-81	BEARING	51	532 42 29-41	SWING PLATE
25	873 93 05-00	NUT 5/16-18	52	532 13 20-10	NUT 3/8-16
26	532 19 95-09	RUBBER WHEEL PLATE	53	532 42 88-67	SCREW 5/16-18 X .750
27	585 02 10-01	RUBBER RING	54	817 00 05-10	BOLT 5/16-18 X .625

**NOTE:** All component dimensions given in U.S. inches. 1 inch = 25.4 mm  
**IMPORTANT:** Use only Original Equipment Manufacturer (O.E.M.) replacement parts.  
 Failure to do so could be hazardous, damage your snow thrower and void your warranty.

# REPAIR PARTS SNOW THROWER - - MODEL NUMBER PR624ES (96192003703) DRIVE

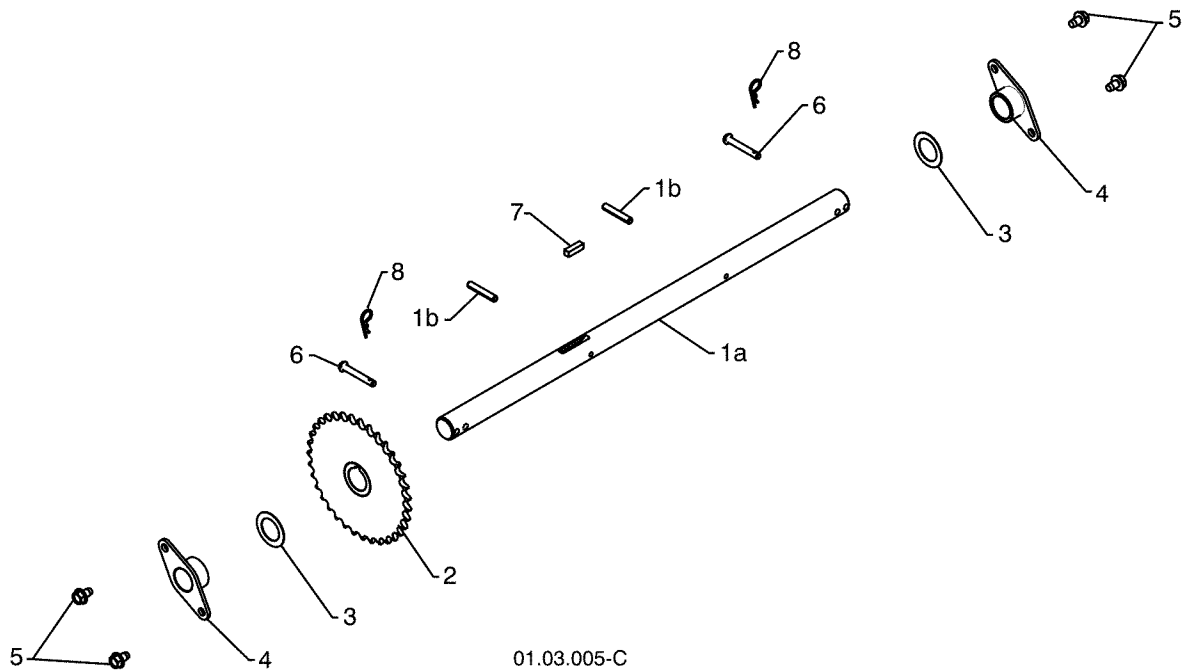

01.03.005-C

KEY NO.	PART NO.	DESCRIPTION
1	532 18 82-26	AXLE ASSEMBLY (assy of 1a,1b)
1a	532 17 93-52	AXLE SHAFT
1b	532 18 42-06	ROLL PIN 3/16
2	532 40 26-91	SPROCKET
3	532 44 49-49	THRUST WASHER
4	532 17 98-30	BEARING
5	817 49 05-08	BOLT 5/16-18 X .500
6	532 17 12-71	PIN
7	532 18 92-82	SQUARE KEY
8	532 12 47-88	RETAINER PIN

**NOTE:** All component dimensions given in U.S. inches. 1 inch = 25.4 mm  
**IMPORTANT:** Use only Original Equipment Manufacturer (O.E.M.) replacement parts.  
 Failure to do so could be hazardous, damage your snow thrower and void your warranty.



**REPAIR PARTS SNOW THROWER - - MODEL NUMBER PR624ES (96192003703)  
CHASSIS / ENGINE / PULLEYS**

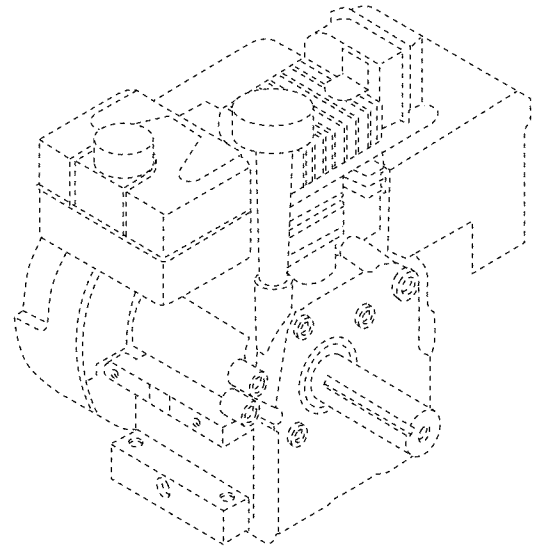
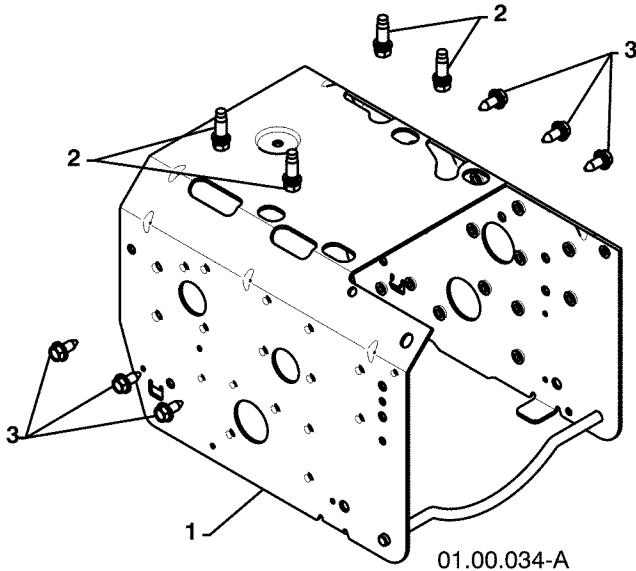

KEY NO.	PART NO.	DESCRIPTION
--	532 43 60-67	COMPLETE LCT ENGINE PW2HK1865017-E
1	532 43 88-40	FRAME
2	532 15 04-06	BOLT 3/8-16
3	532 42 88-67	SCREW 5/16-18 X .750

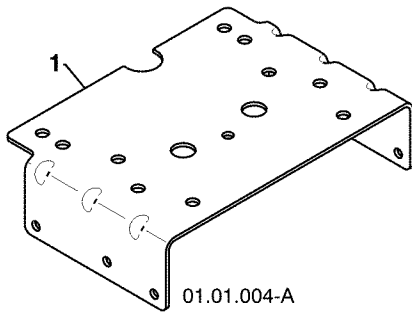

KEY NO.	PART NO.	DESCRIPTION
1	532 43 88-42	ENGINE MOUNTING PLATE

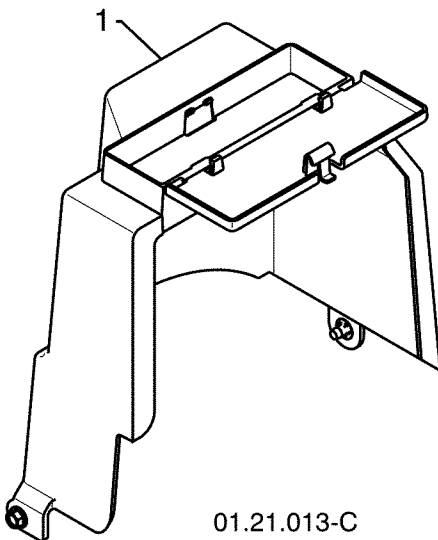

KEY NO.	PART NO.	DESCRIPTION
1	532 44 30-30	COVER ASSEMBLY

**NOTE:** All component dimensions given in U.S. inches. 1 inch = 25.4 mm  
**IMPORTANT:** Use only Original Equipment Manufacturer (O.E.M.) replacement parts.  
 Failure to do so could be hazardous, damage your snow thrower and void your warranty.

# REPAIR PARTS SNOW THROWER - - MODEL NUMBER PR624ES (96192003703)

## CHASSIS / ENGINE / PULLEYS

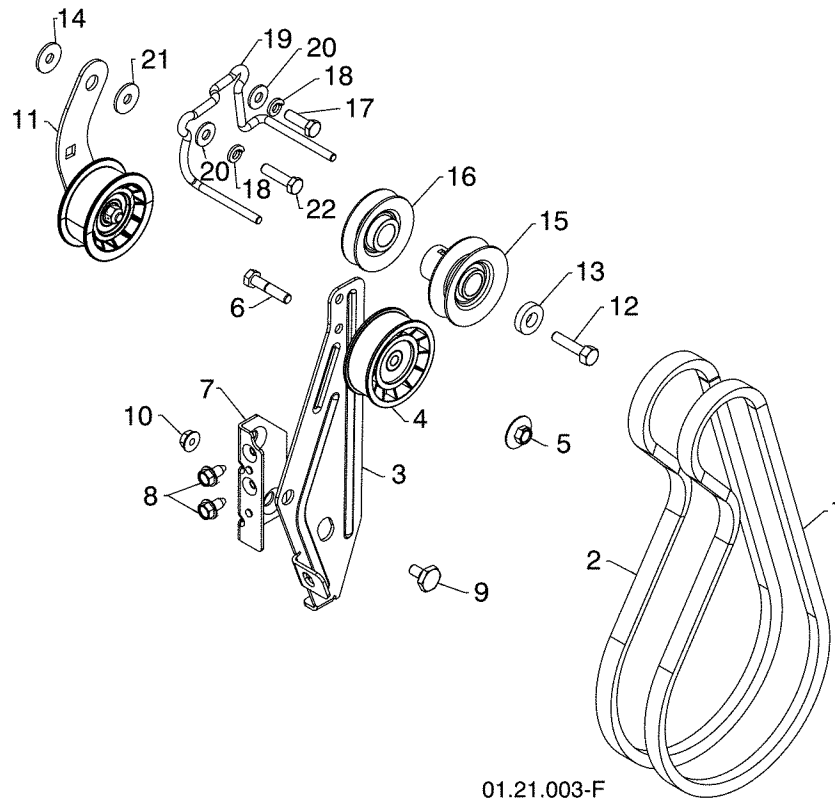

01.21.003-F

KEY NO.	PART NO.	DESCRIPTION	KEY NO.	PART NO.	DESCRIPTION
1	532 40 80-07	IMPELLER BELT	13	532 40 00-26	WASHER
2	532 41 97-44	TRACTION BELT	14	532 05 92-89	WASHER
3	584 23 24-02	IDLER ARM BRACKET	15	532 42 64-91	PULLEY ENG IMPELLER
4	532 18 05-23	IDLER PULLEY	16	532 42 64-90	PULLEY ENG TRACTION
5	532 42 65-89	NUT 5/16-18	17	874 61 05-16	SCREW 5/16-18 X 1.00
6	874 78 05-24	CAPSCREW 5/16-18 X 1.50	18	810 04 05-00	LOCKWASER 5/16
7	585 28 49-01	IDLER BRACKET	19	585 05 82-01	BELT GUIDE
8	817 00 05-10	SCREW 5/16-18 HEX	20	532 15 54-15	WASHER
9	532 42 42-97	SHOULDER BOLT 5/16-18 X .500	21	532 17 53-31	IDLER BUSHING
10	532 75 11-53	NUT 5/16-18 TOP LOCK	22	874 61 05-20	CAPSCREW HEX HEAD 5/16 X 1.25 GR5
11	585 23 84-01	TRACTION IDLER ARM ASM			
12	532 85 10-84	CAPSCREW 3/8-24 X 1.375			

**NOTE:** All component dimensions given in U.S. inches. 1 inch = 25.4 mm  
**IMPORTANT:** Use only Original Equipment Manufacturer (O.E.M.) replacement parts.  
 Failure to do so could be hazardous, damage your snow thrower and void your warranty.

# REPAIR PARTS SNOW THROWER - - MODEL NUMBER PR624ES (96192003703) WHEELS

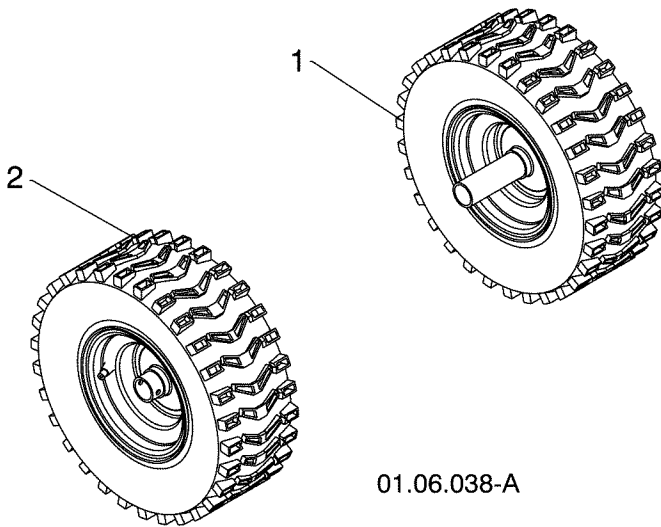

KEY NO.	PART NO.	DESCRIPTION
1	580 62 77-04	WHEEL 13 X 4 NPS RH 1. 428
2	580 62 76-04	WHEEL 13 X 4 NPS LH 1. 428

**NOTE:** All component dimensions given in U.S. inches. 1 inch = 25.4 mm  
**IMPORTANT:** Use only Original Equipment Manufacturer (O.E.M.) replacement parts.  
Failure to do so could be hazardous, damage your snow thrower and void your warranty.

# REPAIR PARTS SNOW THROWER - - MODEL NUMBER PR624ES (96192003703)

## BAG OF PARTS

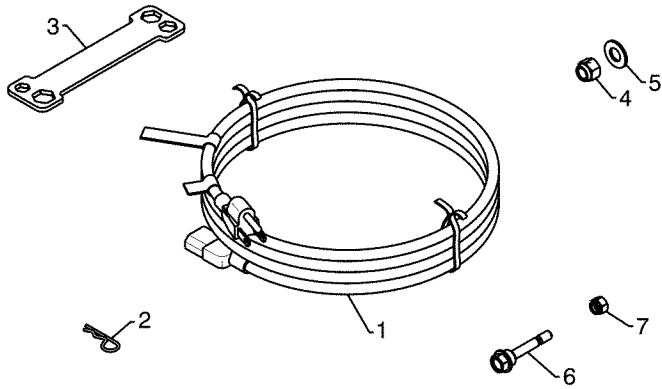

01.14.004-B

KEY NO.	PART NO.	DESCRIPTION
1	532 19 85-63	POWER CORD
2	532 16 96-75	RETAINER PIN
3	532 42 91-12	WRENCH
4	873 80 06-00	LOCKNUT 3/8-16
5	819 13 13-16	WASHER 3/8
6	532 19 20-90	SHEAR BOLT 1/4-20 X 1-3/4
7	873 80 04-00	LOCKNUT 1/4-20

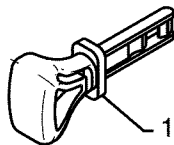

01.14.009-B

KEY NO.	PART NO.	DESCRIPTION
1	532 44 30-59	SAFETY IGNITION KEY KIT

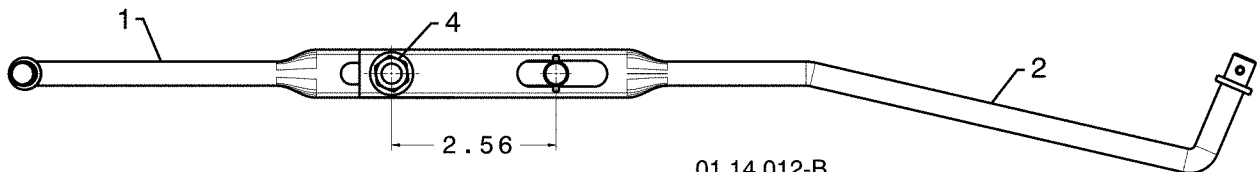
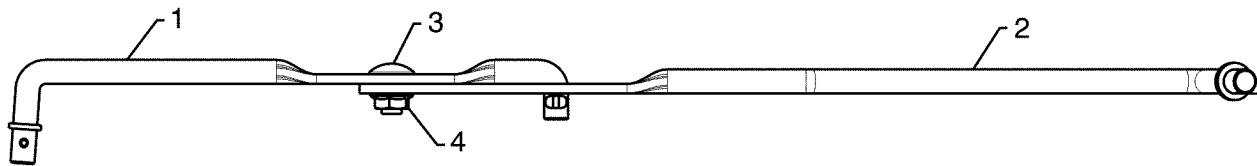

01.14.012-B

KEY NO.	PART NO.	DESCRIPTION
1	532 18 04-45	SHIFTER ROD TOP
2	532 18 77-16	SHIFTER ROD BOTTOM
3	872 27 05-05	CARRIAGE BOLT 5/16-18 X .75
4	532 15 53-77	NUT 5/16-18

**NOTE:** All component dimensions given in U.S. inches. 1 inch = 25.4 mm  
**IMPORTANT:** Use only Original Equipment Manufacturer (O.E.M.) replacement parts.  
 Failure to do so could be hazardous, damage your snow thrower and void your warranty.

# REPAIR PARTS SNOW THROWER - - MODEL NUMBER PR624ES (96192003703)

## DECALS

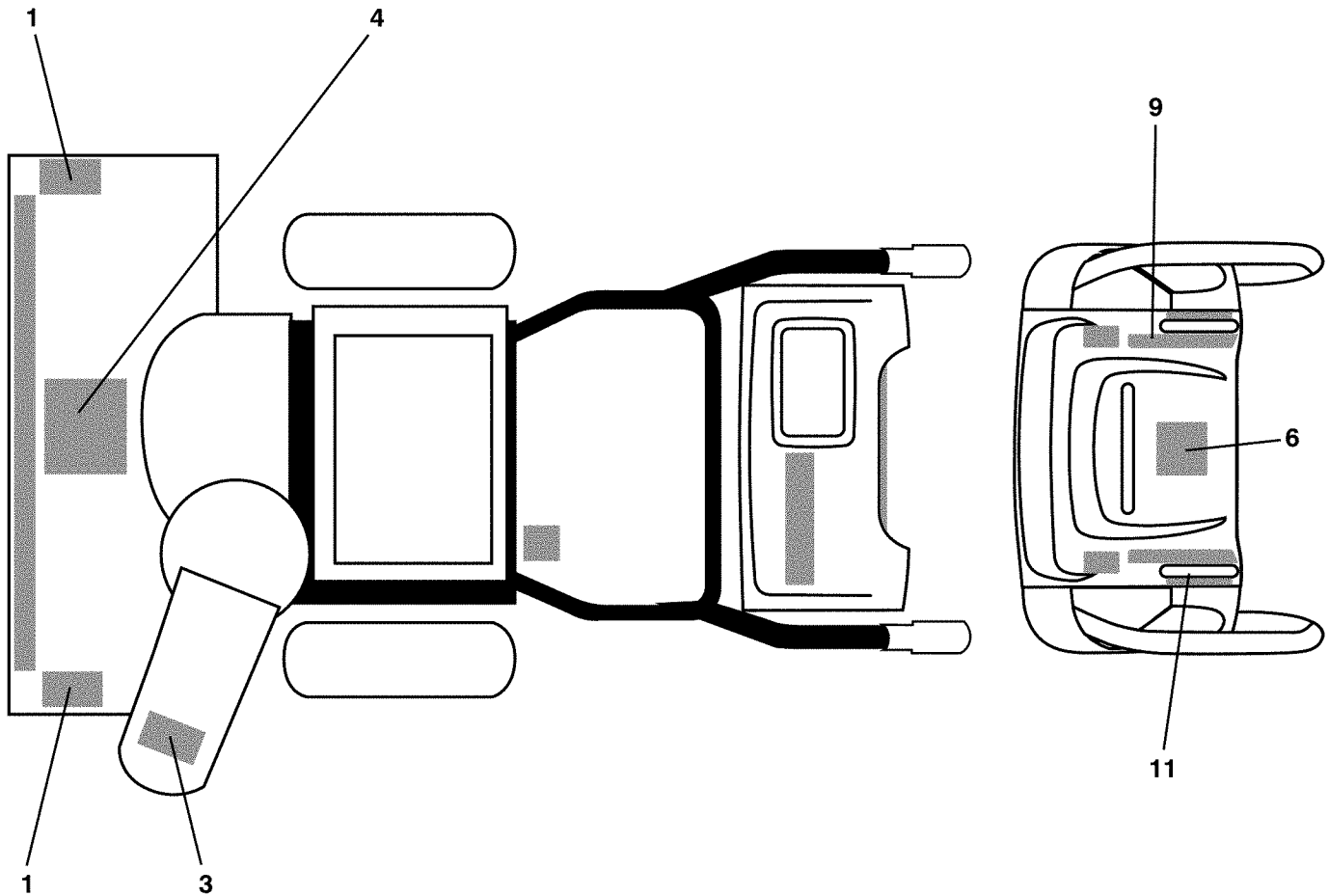

KEY NO.	PART NO.	DESCRIPTION
1	532 18 10-37	DECAL, DANGER
3	532 18 10-35	DECAL, DANGER, DEFLECTOR
4	532 18 10-42	DECAL, DANGER
6	532 18 10-33	DECAL, INSTRUCTION
9	581 43 01-01	DECAL, CON RT SPD/LEV/PWST
11	581 43 01-02	DECAL, CON LT WD/DEF
--	580 92 45-27	OWNER'S MANUAL, ENGLISH
--	580 92 45-32	OWNER'S MANUAL, FRENCH

**NOTE:** All component dimensions given in U.S. inches. 1 inch = 25.4 mm  
**IMPORTANT:** Use only Original Equipment Manufacturer (O.E.M.) replacement parts.  
 Failure to do so could be hazardous, damage your snow thrower and void your warranty.

# REPAIR PARTS

# SNOW THROWER - MODEL PR624ES (96192003703)

## COMPLETE ENGINE-532436067

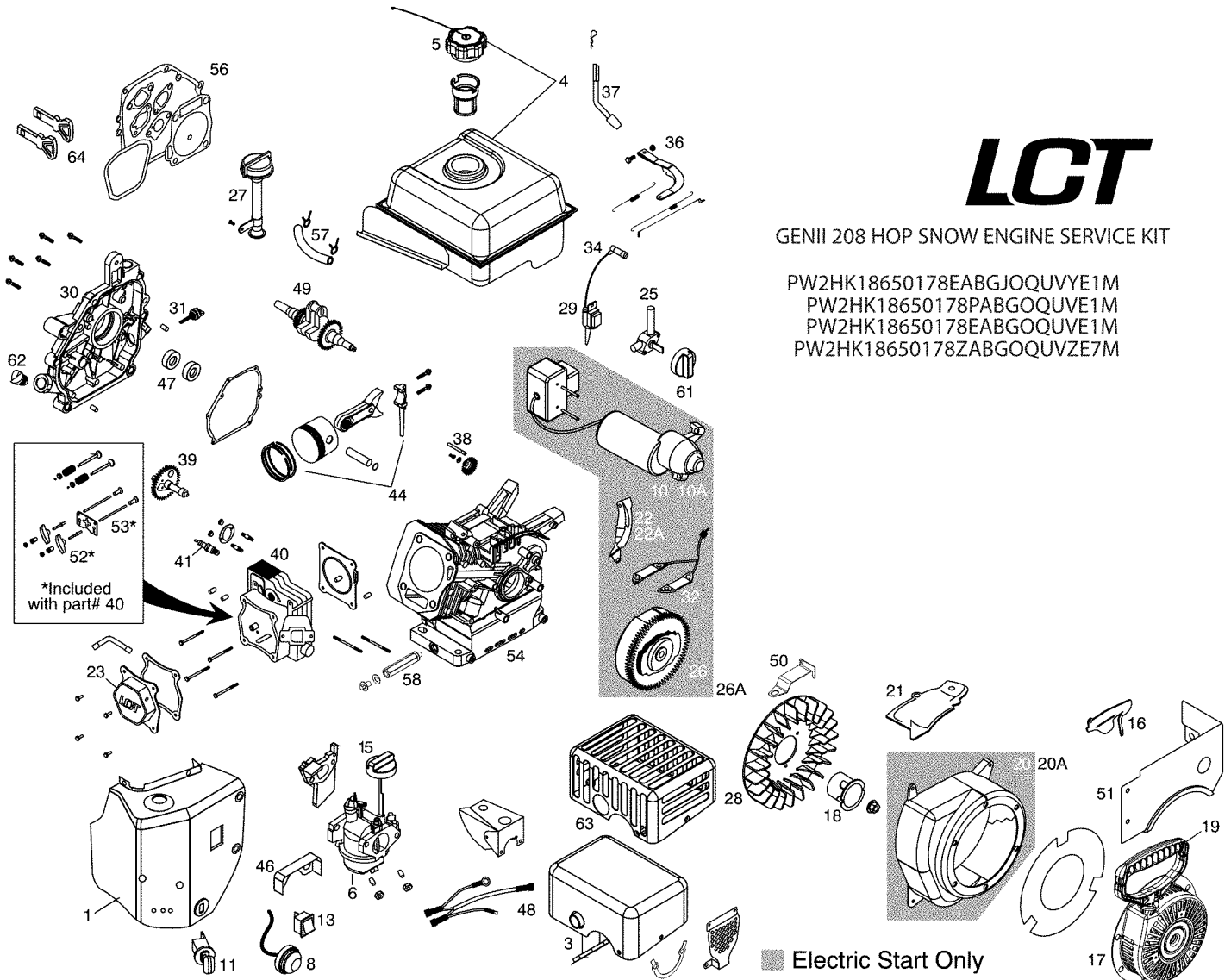

# LCT

GENII 208 HOP SNOW ENGINE SERVICE KIT

- PW2HK18650178EABGJOQUVYE1M
- PW2HK18650178PABGOQUVE1M
- PW2HK18650178EABGOQUVE1M
- PW2HK18650178ZABGOQUVZE7M

**NOTE:** All component dimensions given in U.S. inches. 1 inch = 25.4 mm

**IMPORTANT:** Use only Original Equipment Manufacturer (O.E.M.) replacement parts. Failure to do so could be hazardous, damage your snow thrower and void your warranty.

# REPAIR PARTS

# SNOW THROWER - MODEL PR624ES (96192003703)

## COMPLETE ENGINE-532436067

KEY PART NO. NO.	DESCRIPTION	KEY PART NO. NO.	DESCRIPTION		
1	532 43 65-61	Heater Box Assembly-Snow	28	532 42 05-86	Flywheel Fan
3	532 43 65-63	Muffler Assembly-Snow	29	532 44 39-34	Ignition Coil Assy (CDI)
4	532 43 65-64	Fuel Tank Assembly-Snow	30	532 42 06-06	Crankcase Cover Assy
5	532 42 49-42	Oversized Fuel Tank Cap (Click Style)	31	532 42 09-61	Black Oil Dipstick
6	532 43 65-65	Carburetor Assembly-Snow	32	532 42 49-59	Charging Coil Dc
8	532 42 49-49	Primer Bulb Assembly W/Hose-Snow	34	532 43 69-66	Spark Plug Boot
10	532 43 64-66	Electric Starter Assembly-Snow	36	532 42 06-01	Governor Arm Assy
10A	532 43 66-71	European 230V Electric Starter	37	532 42 06-02	Governor Shaft
11	532 42 49-54	Key Switch Assembly	38	532 42 96-46	Governor Gear Assy
13	532 42 49-57	On/Off Switch	39	532 42 05-84	Camshaft
15	532 42 92-24	Choke Knob-Snow	40	532 42 05-78	Cylinder Head Assy
16	532 42 49-60	Governor Linkage Shield Plate	41	532 42 49-39	Spark Plug
17	532 43 69-67	Recoil Starter Assembly-Snow	44	532 42 05-82	Piston And Rod Assy
18	532 43 69-68	Starter Cup Small	46	532 42 92-60	Vapor Shield
19	532 42 49-68	Snow Starter Grip	47	532 42 95-99	Seal Kit
20	532 42 49-71	Blower Housing Assembly, Electric Start-Snow (Black)	48	532 42 92-62	Wire Harness
20A	532 42 92-30	Blower Housing Assembly Manual Start-Snow (Black)	49	532 42 96-00	Crankshaft
21	532 42 49-73	Shield, Cylinder	50	532 42 92-59	Speed Control Bracket
22	532 42 49-75	Shield, Flywheel-Electric Start (If Equipped)	51	532 43 65-62	Fuel Tank Skirt
22A	532 42 95-96	Shield, Flywheel-Manual Start	52	532 42 96-91	Rocker Asm Kit
23	532 42 05-80	Valve Cover	53	532 42 05-79	Push Rod Kit
25	532 42 92-34	Fuel Petcock, Snow	54	532 42 65-67	Cylinder Assy
26	532 42 92-35	Flywheel Assembly, Electric Start- Snow	56	532 42 96-01	Gasket Kit
26A	532 42 05-85	Flywheel Assembly, Manual Start- Snow	57	532 43 21-44	Fuel Hose Kit
27	532 42 49-69	High Oil Fill Assy Kit, Snow	58	532 43 26-86	Extended Oil Drain Tube
			61	532 43 27-52	Fuel Knob-Snow
			62	532 42 95-98	Non-Removable Oil Plug
			63	532 43 66-72	Ce Compliant Muffler Shield
			64	532 44 30-59	Red Key Set

**NOTE:** All component dimensions given in U.S. inches. 1 inch = 25.4 mm

**IMPORTANT:** Use only Original Equipment Manufacturer (O.E.M.) replacement parts.  
Failure to do so could be hazardous, damage your snow thrower and void your warranty.

## LIMITED WARRANTY

The Manufacturer warrants to the original consumer purchaser that this product as manufactured is free from defects in materials and workmanship. For a period of two (2) years from date of purchase by the original consumer purchaser, we will repair or replace, at our option, without charge for parts or labor incurred in replacing parts, any part which we find to be defective due to materials or workmanship. This Warranty is subject to the following limitations and exclusions.

1. This warranty does not apply to the engine, transaxle/transmission components, battery (except as noted below) or components parts thereof. Please refer to the applicable manufacturer's warranty on these items.
2. Transportation charges for the movement of any power equipment unit or attachment are the responsibility of the purchaser. Transportation charges for any parts submitted for replacement under this warranty must be paid by the purchaser unless such return is requested by the manufacturer.
3. Battery Warranty: On products equipped with a Battery, we will replace, without charge to you, any battery which we find to be defective in manufacture, during the first ninety (90) days of ownership. After ninety (90) days, we will exchange the Battery, charging you 1/12 of the price of a new Battery for each full month from the date of the original sale. Battery must be maintained in accordance with the instructions furnished.
4. The Warranty period for any products used for rental or commercial purposes is limited to 90 days from the date of original purchase.
5. This Warranty applies only to products which have been properly assembled, adjusted, operated, and maintained in accordance with the instructions furnished. This Warranty does not apply to any product which has been subjected to alteration, misuse, abuse, improper assembly or installation, delivery damage, or to normal wear of the product.
6. Exclusions: Excluded from this Warranty are belts, blades, blade adapters, normal wear, normal adjustments, standard hardware and normal maintenance.
7. In the event you have a claim under this Warranty, you must return the product to an authorized service dealer.

Should you have any unanswered questions concerning this Warranty, please contact:

Poulan Pro  
Outdoor Products Customer Service Dept.  
9335 Harris Corners Parkway  
Charlotte, NC 28269 USA

In Canada contact:  
Poulan Pro  
5855 Terry Fox Way  
Mississauga, Ontario  
L5V 3E4

giving the model number, serial number and date of purchase of your product and the name and address of the authorized dealer from whom it was purchased.

THIS WARRANTY DOES NOT APPLY TO INCIDENTAL OR CONSEQUENTIAL DAMAGES AND ANY IMPLIED WARRANTIES ARE LIMITED TO THE SAME TIME PERIODS STATED HEREIN FOR OUR EXPRESSED WARRANTIES. Some areas do not allow the limitation of consequential damages or limitations of how long an implied Warranty may last, so the above limitations or exclusions may not apply to you. This Warranty gives you specific legal rights, and you may have other rights which vary from locale to locale.

This is a limited Warranty within the meaning of that term as defined in the Magnuson-Moss Act of 1975.