

# WEIDER<sup>®</sup> PRO 345

Model No. 831.15964.0

Serial No. \_\_\_\_\_

Write the serial number in the space above for reference.

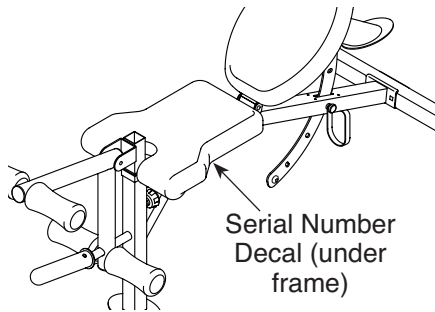

## WEIGHT BENCH EXERCISER User's Manual

- Assembly
- Operation
- Maintenance
- Part List and Drawing

Sears, Roebuck and Co.  
Hoffman Estates, IL 60179

### CAUTION

Read all precautions and instructions in this manual before using this equipment. Keep this manual for future reference.

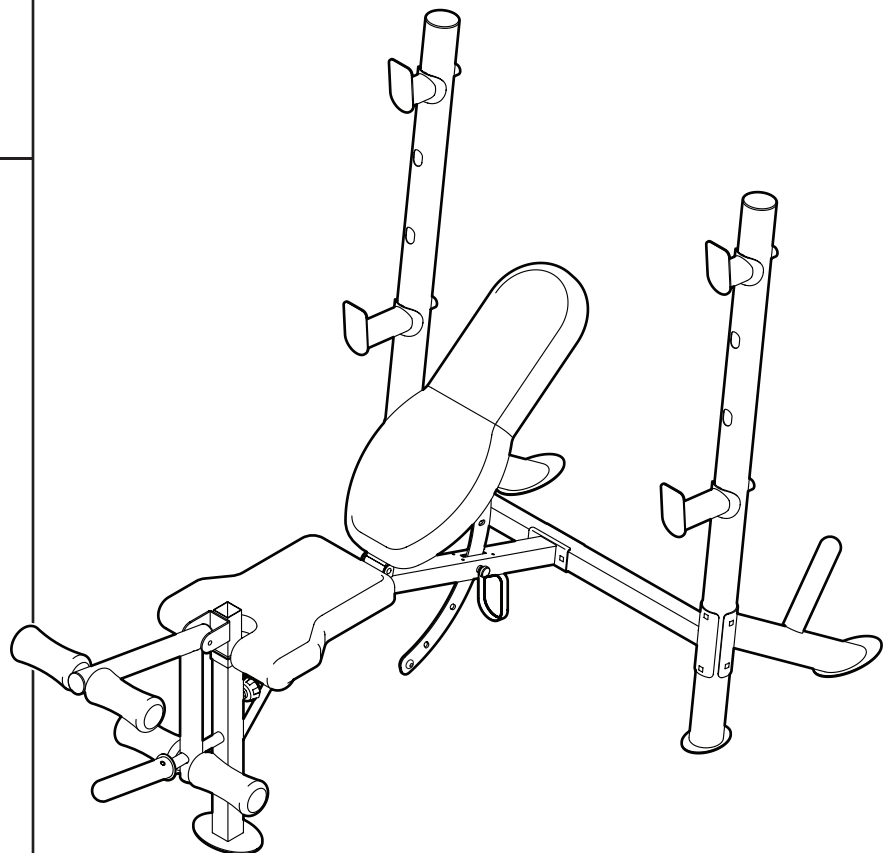

# TABLE OF CONTENTS

WARNING DECAL PLACEMENT .....2

IMPORTANT PRECAUTIONS.....3

BEFORE YOU BEGIN.....4

PART IDENTIFICATION CHART.....5

ASSEMBLY.....6

ADJUSTMENT.....12

EXERCISE GUIDELINES.....14

PART LIST.....18

EXPLODED DRAWING.....19

ORDERING REPLACEMENT PARTS..... Back Cover

90 DAY FULL WARRANTY..... Back Cover

## WARNING DECAL PLACEMENT

This drawing shows the location(s) of the warning decal(s). **If a decal is missing or illegible, call 1-877-992-5999 and request a free replacement decal. Apply the decal in the location shown.**  
 Note: The decal(s) may not be shown at actual size.

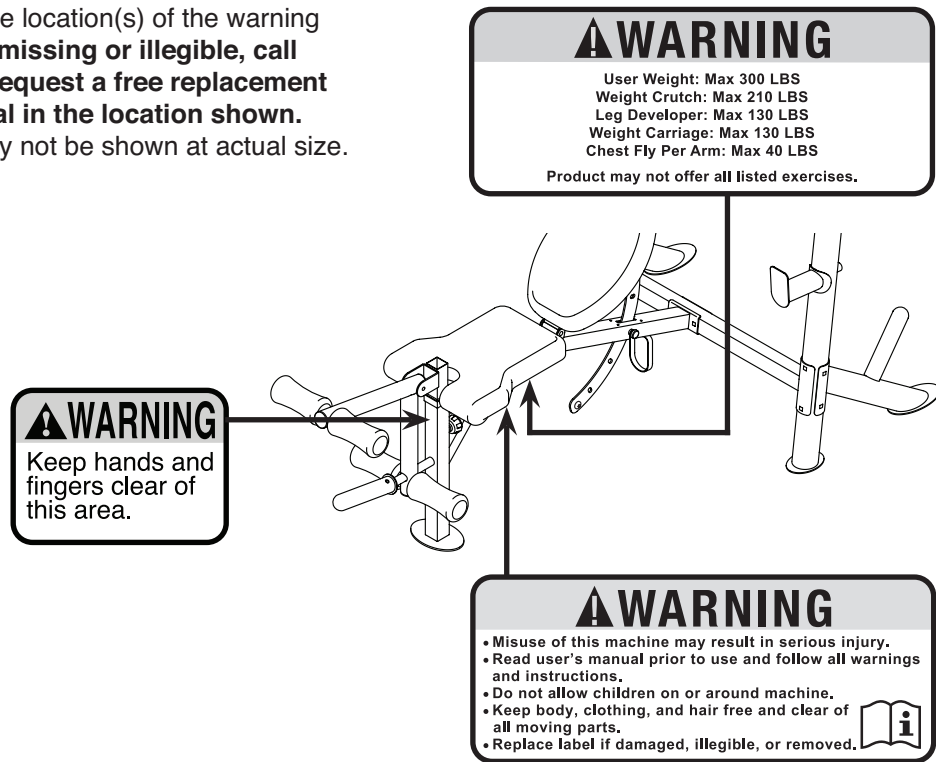

# IMPORTANT PRECAUTIONS

**⚠️ WARNING:** To reduce the risk of serious injury, read all important precautions and instructions in this manual and all warnings on your weight bench before using your weight bench. Sears assumes no responsibility for personal injury or property damage sustained by or through the use of this product.

1. It is the responsibility of the owner to ensure that all users of the weight bench are adequately informed of all precautions.
2. Before beginning any exercise program, consult your physician. This is especially important for persons over age 35 or persons with pre-existing health problems.
3. The weight bench is not intended for use by persons with reduced physical, sensory, or mental capabilities or lack of experience and knowledge, unless they are given supervision or instruction about use of the weight bench by someone responsible for their safety.
4. Use the weight bench only as described in this manual.
5. The weight bench is intended for home use only. Do not use the weight bench in any commercial, rental, or institutional setting.
6. Keep the weight bench indoors, away from moisture and dust. Do not put the weight bench in a garage or covered patio, or near water.
7. Place the weight bench on a level surface, with enough clearance around the weight bench to mount, dismount, and use the weight bench. To protect the floor or carpet from damage, place a mat under the weight bench.
8. Inspect and properly tighten all parts each time the weight bench is used. Replace any worn parts immediately.
9. Keep children under age 13 and pets away from the weight bench at all times.
10. Keep hands and feet away from moving parts.
11. Always wear athletic shoes for foot protection while using the weight bench.
12. The weight bench is designed to support a maximum user weight of 300 lbs. (136 kg), and a maximum total weight of 510 lbs. (231 kg). Do not place more than 210 lbs. (95 kg), including a barbell and weights (not included), on the weight rests. Do not place more than 130 lbs. (59 kg) on the leg lever.
13. Always place the same amount of weight on both ends of your barbell. While adding or removing weights, always keep some weight on both ends of your barbell to prevent the barbell from tipping. Always secure weights with your spring collars.
14. Before you use the weight rests, make sure that the weight rests are properly attached to the uprights. In addition, make sure that the spotters are properly attached to the uprights.
15. Always make sure that the locking pin is fully inserted into the seat frame and into the pivot bracket before you use the weight bench.
16. Always exercise with a partner. Your partner should be ready to catch your barbell if you cannot complete a repetition.
17. Over exercising may result in serious injury or death. If you feel faint, if you become short of breath, or if you experience pain while exercising, stop immediately and cool down.

# BEFORE YOU BEGIN

Thank you for selecting the WEIDER® PRO 345 weight bench. The versatile PRO 345 weight bench is designed to develop every major muscle group of the body. Whether your goal is to have a shapely figure, dramatic muscle size and strength, or a healthier cardiovascular system, the weight bench will help you to achieve the specific results you want.

**For your benefit, read this manual carefully before using the weight bench.** If you have questions after

reading this manual, please see the back cover of this manual. To help us assist you, note the product model number and serial number before contacting us. The model number and the location of the serial number decal are shown on the front cover of this manual.

Before reading further, please review the drawing below and familiarize yourself with the labeled parts.

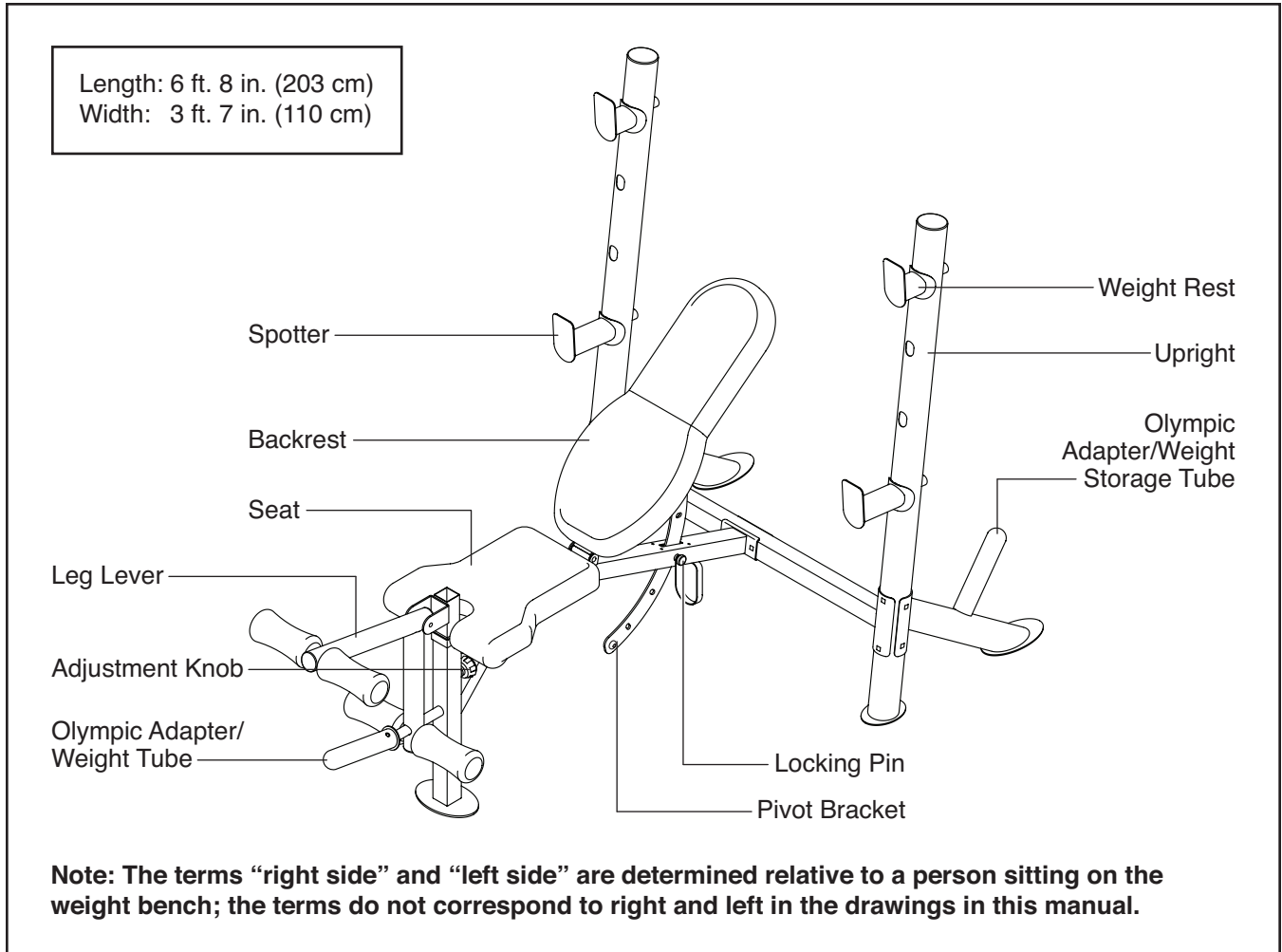

# PART IDENTIFICATION CHART

Use the drawings below to identify the small parts needed for assembly. The number in parentheses below each drawing is the key number of the part, from the PART LIST near the end of this manual. **Note: If a part is not in the hardware kit, check to see if it has been preassembled. Extra hardware may be included. If a part is missing, call 1-877-992-5999.**

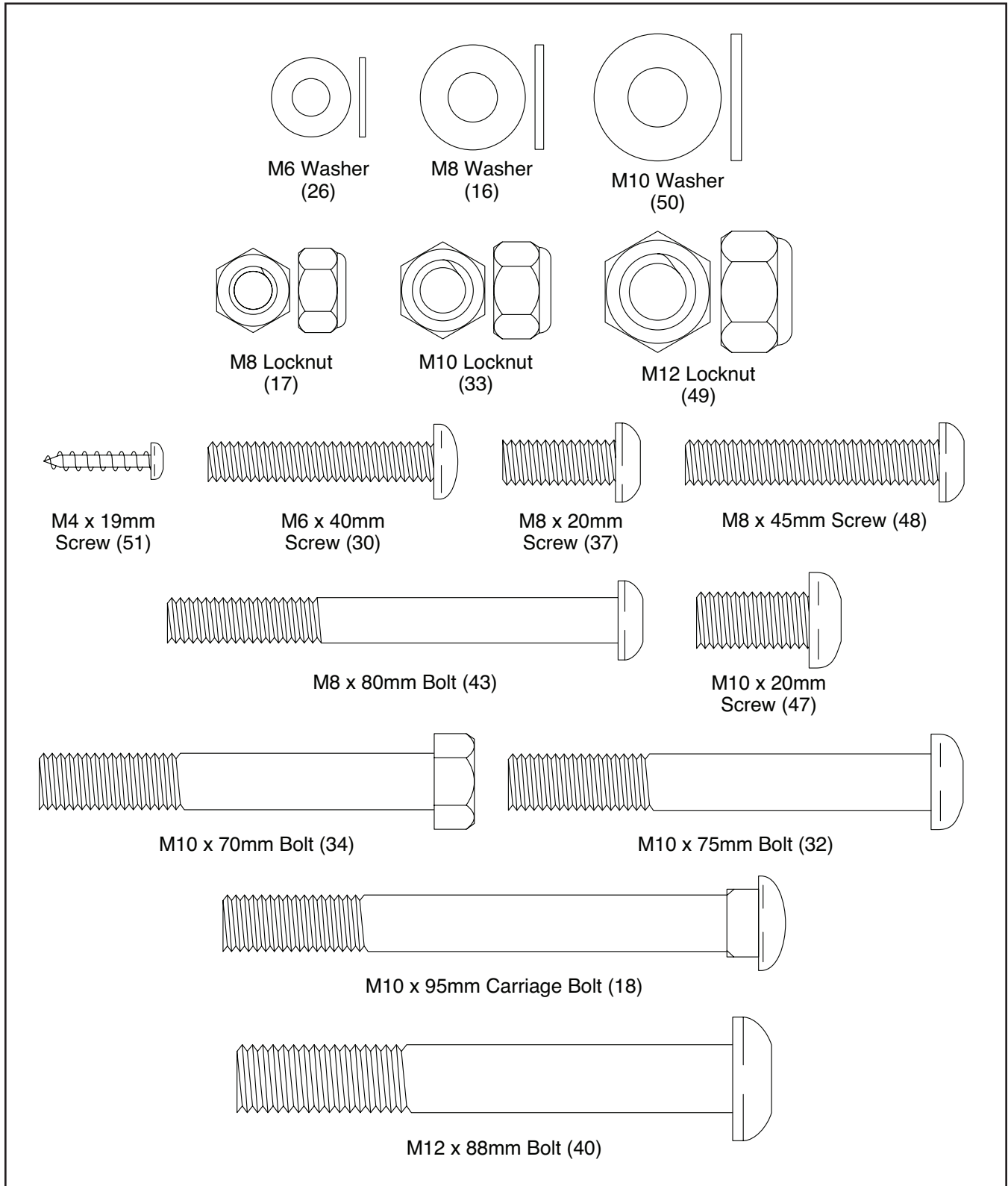

# ASSEMBLY

- Assembly requires two persons.
- Because of its weight and size, assemble the weight bench in the location where it will be used. Make sure that there is enough clearance to walk around the weight bench as you assemble it.
- Place all parts in a cleared area and remove the packing materials. Do not dispose of the packing materials until you finish all assembly steps.

- To identify small parts, see page 5.
- In addition to the included tool(s), assembly requires the following tools:

one adjustable wrench



one Phillips screwdriver



Assembly may be easier if you have a set of wrenches. To avoid damaging parts, do not use power tools.

## 1. Go to [www.weiderservice.com/registration](http://www.weiderservice.com/registration) on your computer and register your product.

- activates your warranty
- saves you time if you ever need to contact Customer Care
- allows us to notify you of upgrades and offers

Note: If you do not have Internet access, call 1-877-992-5999 and register your product.

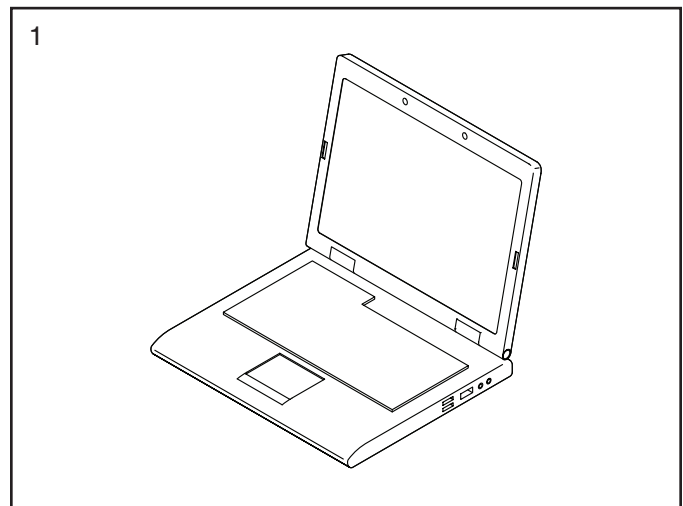

## 2. Identify the Left and Right Stabilizers (13, 38).

Attach the Crossbar (3) and the Left Stabilizer (13) to an Upright (1) with four M10 x 95mm Carriage Bolts (18) and four M10 Locknuts (33); **do not tighten the Locknuts yet.**

**Attach the Crossbar (3) and the Right Stabilizer (38) to the other Upright (1) in the same way.**

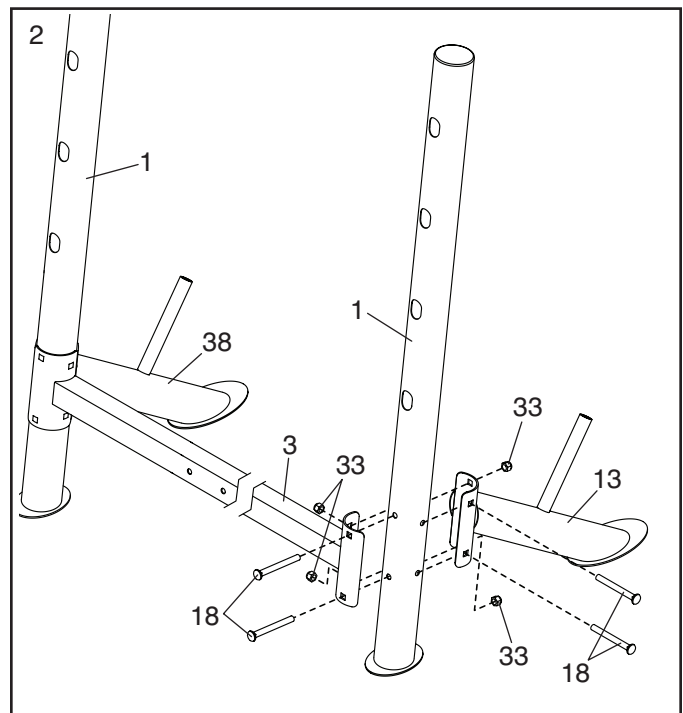

- Attach the Seat Frame (2) to the Lower Front Leg (8) with three M10 x 20mm Screws (47) and three M10 Washers (50); **do not tighten the Screws yet.**

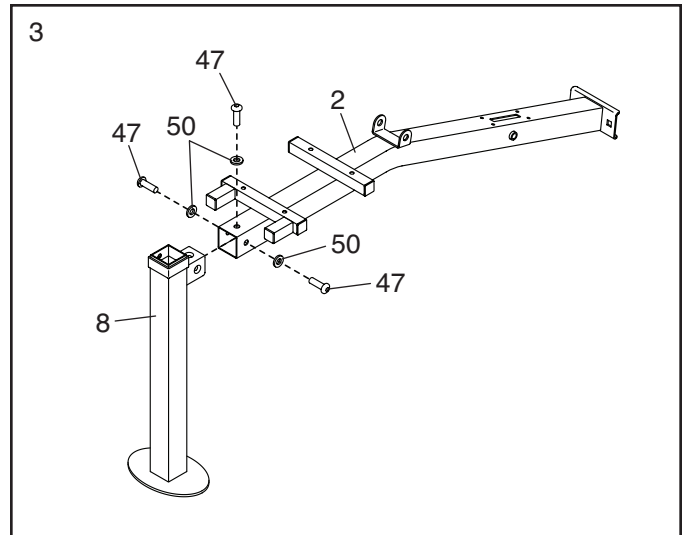

- Attach the Brace (44) to the Seat Frame (2) and the Lower Front Leg (8) with two M8 x 20mm Screws (37); **do not tighten the Screws yet.**

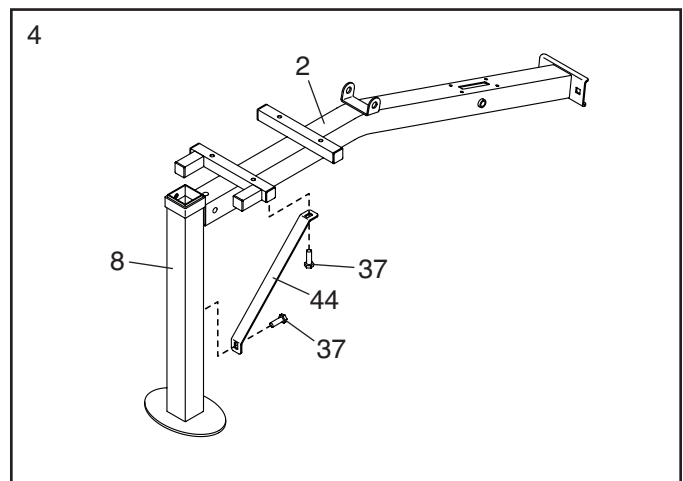

- Attach the Seat Frame (2) to the Crossbar (3) with two M10 x 70mm Bolts (34), the Support Bracket (22), and two M10 Locknuts (33).

**See steps 2–4.** Tighten the M10 Locknuts (33), the M10 x 20mm Screws (47), and the M8 x 20mm Screws (37).

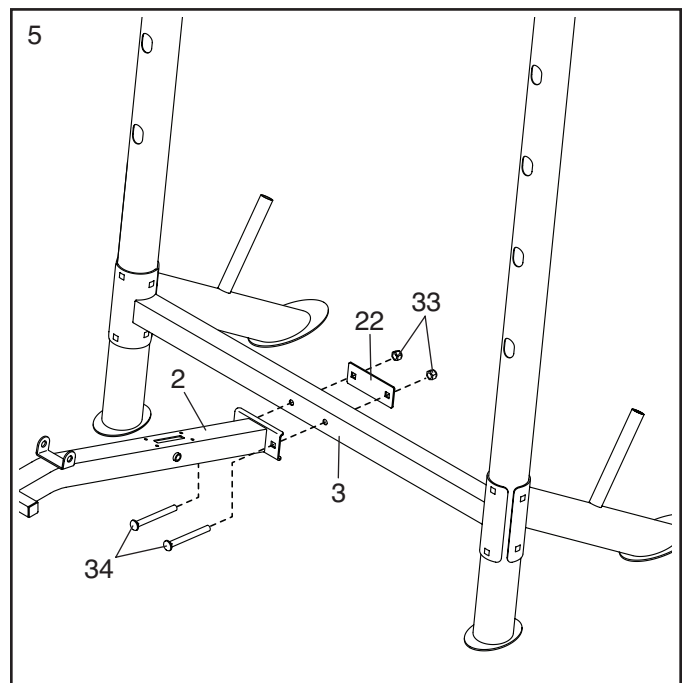

6. Insert a Pad Tube (10) into a hole in the Leg Lever (4). Slide a Foam Pad (23) onto each side of the Pad Tube.

Then, press a Foam Pad Cap (41) into each Foam Pad (23).

**Attach the other Pad Tube (not shown), two Foam Pads (23), and Foam Pad Caps (41) in the same way.**

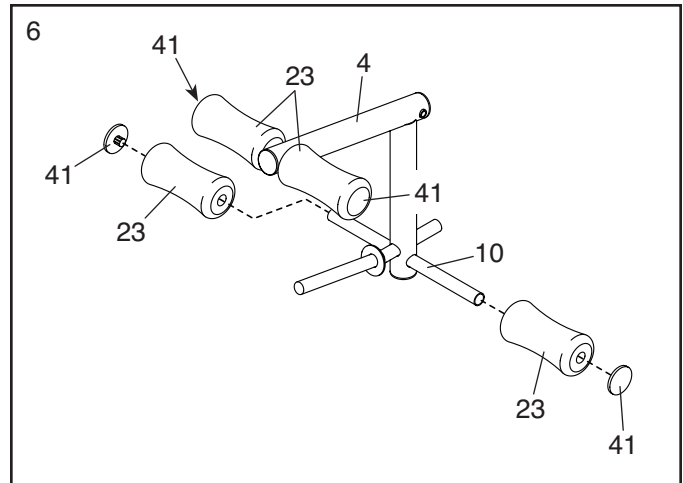

7. Using a plastic bag to keep your fingers clean, apply a generous amount of the included grease to an M10 x 75mm Bolt (32).

Attach the Leg Lever (4) to the Upper Front Leg (27) with the M10 x 75mm Bolt (32) and an M10 Locknut (33). **Do not overtighten the Locknut; the Leg Lever must pivot easily.**

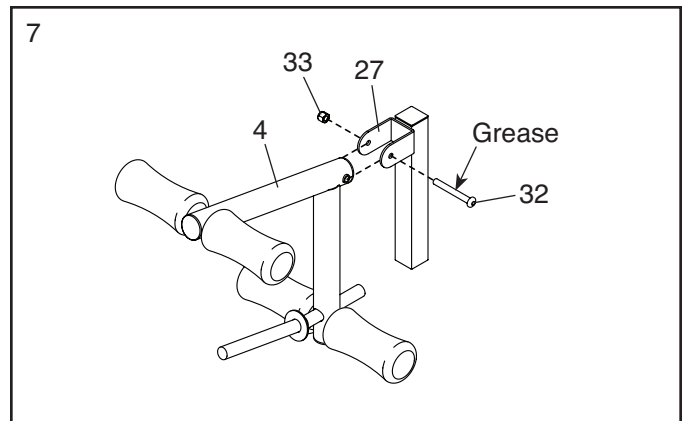

8. Loosen and pull the Adjustment Knob (31) outward and insert the Upper Front Leg (27) into the Lower Front Leg (8).

Move the Upper Front Leg (27) to the desired position, release the Adjustment Knob (31) into an adjustment hole in the Upper Front Leg, and then tighten the Adjustment Knob.

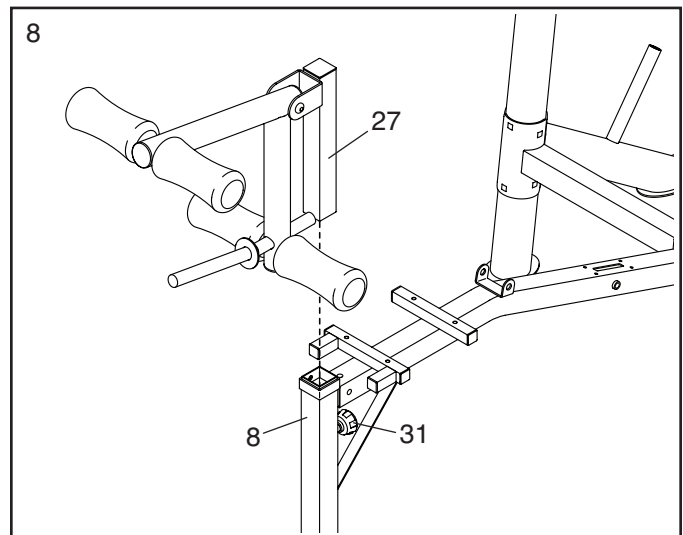



9. Attach the tether on the Locking Pin (36) to the Seat Frame (2) with an M4 x 19mm Screw (51).

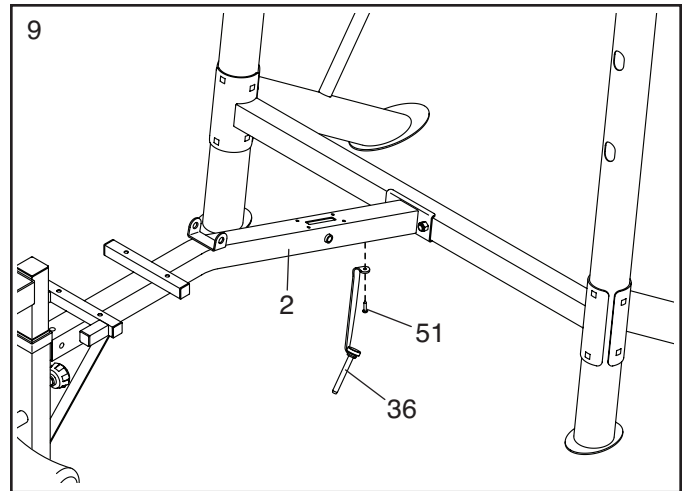

10. Orient the Backrest Frame (5) so that the pivot tube is in the location shown. **Make sure that there is a Backrest Frame Bushing (28) in each side of the pivot tube.** If necessary, press a Backrest Frame Bushing into each side of the pivot tube.

Attach the Pivot Bracket (7) to the Backrest Frame (5) with two M8 x 80mm Bolts (43) and two M8 Locknuts (17); **do not tighten the Locknuts yet.**

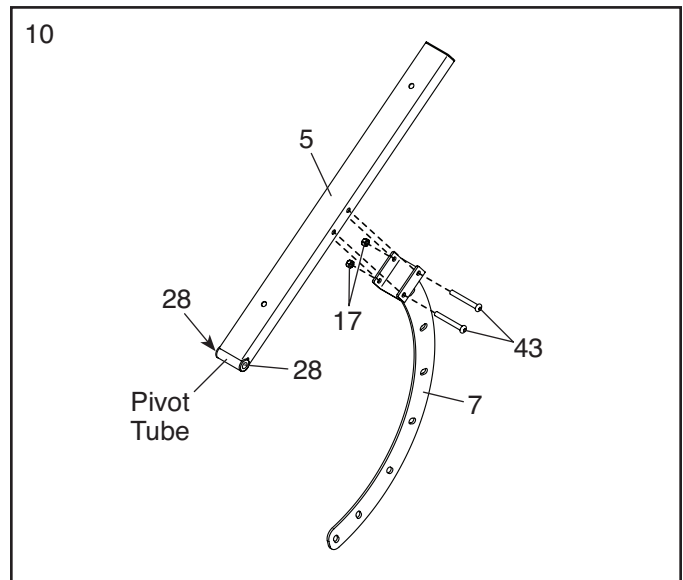

11. Apply a small amount of grease to an M12 x 88mm Bolt (40).

Insert the Pivot Bracket (7) into the slot in the Seat Frame (2).

Next, attach the Backrest Frame (5) to the bracket on the Seat Frame (2) with the M12 x 88mm Bolt (40) and an M12 Locknut (49). **Do not overtighten the Locknut; the Backrest Frame must pivot easily.**

Then, insert the Locking Pin (36) through the Seat Frame (2) into one of the adjustment holes in the Pivot Bracket (7).

**See step 10.** Tighten the M8 Locknuts (17).

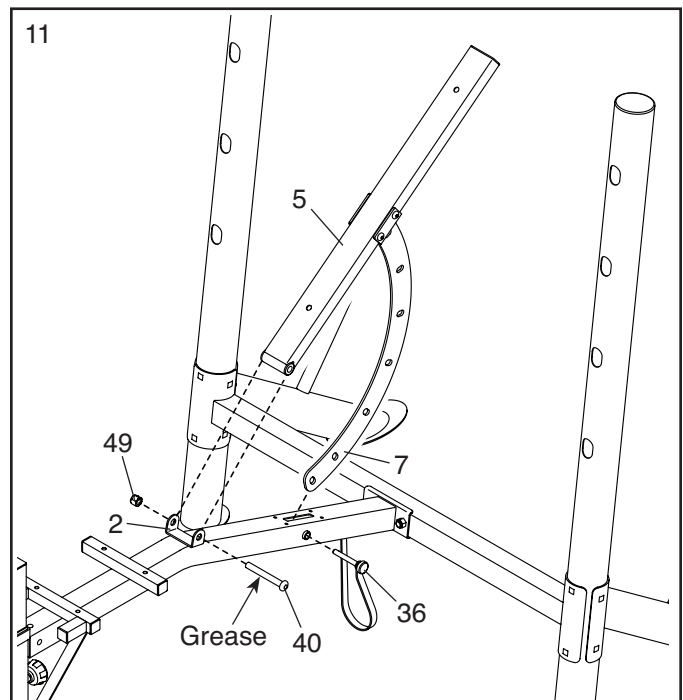

12. Attach an M10 x 20mm Bolt (47) and an M10 Locknut (33) to the hole in the end of the Pivot Bracket (7).

Attach the Backrest (6) to the Backrest Frame (5) with two M8 x 45mm Screws (48) and two M8 Washers (16).

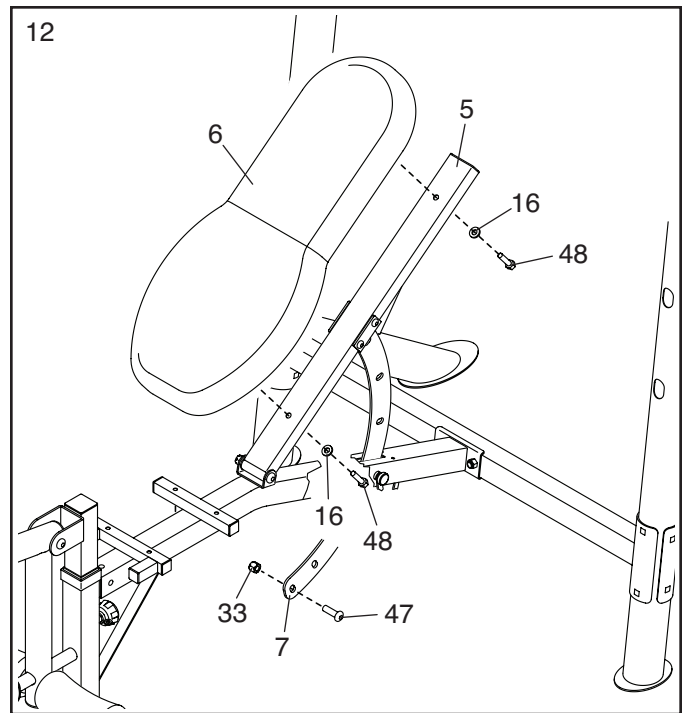

13. Attach the Seat (11) to the Seat Frame (2) with four M6 x 40mm Screws (30) and four M6 Washers (26); **start all the Screws, and then tighten them.**

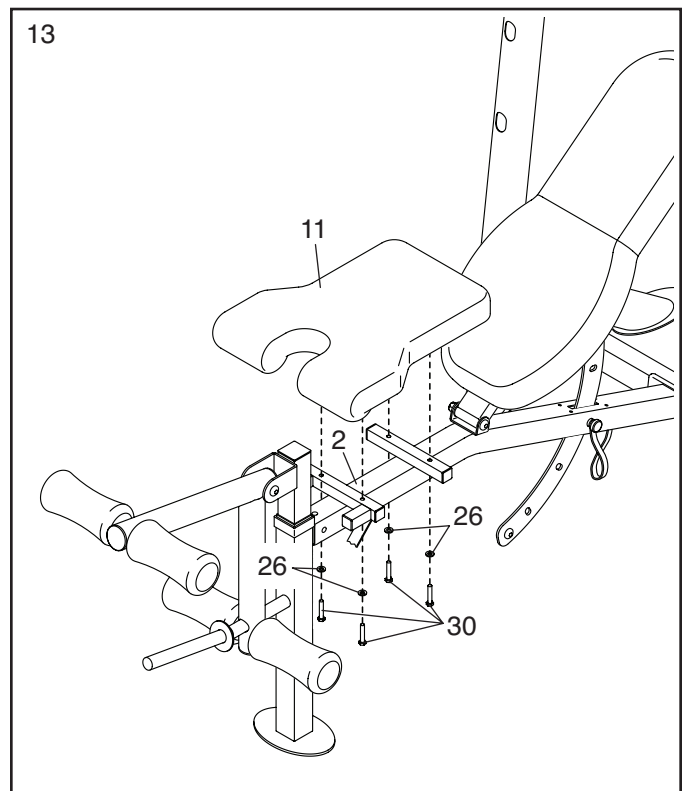

14. Insert a Weight Rest (29) into one of the adjustment holes into an Upright (1). **Repeat this action for the other Weight Rest. Make sure that the Weight Rests are at the same height.**

Then, insert a Spotter (24) into one of the adjustment holes in an Upright (1). **Repeat this action for the other Spotter. Make sure that the Spotters are at the same height.**

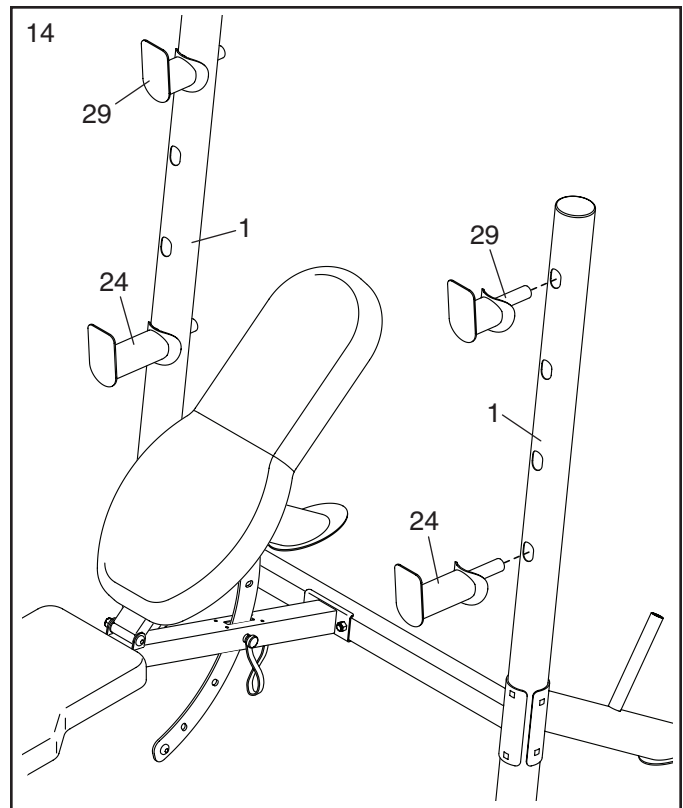

15. **If you plan to use Olympic weights (not included) with the weight bench, perform this assembly step.**

**See the upper drawing.** Slide an Olympic Adapter (25) onto the weight storage tube on the Left Stabilizer (13), and tighten the Set Screw (39) in the Olympic Adapter. **Repeat this action for the Right Stabilizer (not shown).**

**See the lower drawing.** Slide an Olympic Adapter (25) onto the weight tube on the Leg Lever (4), and tighten the Set Screw (39) in the Olympic Adapter.

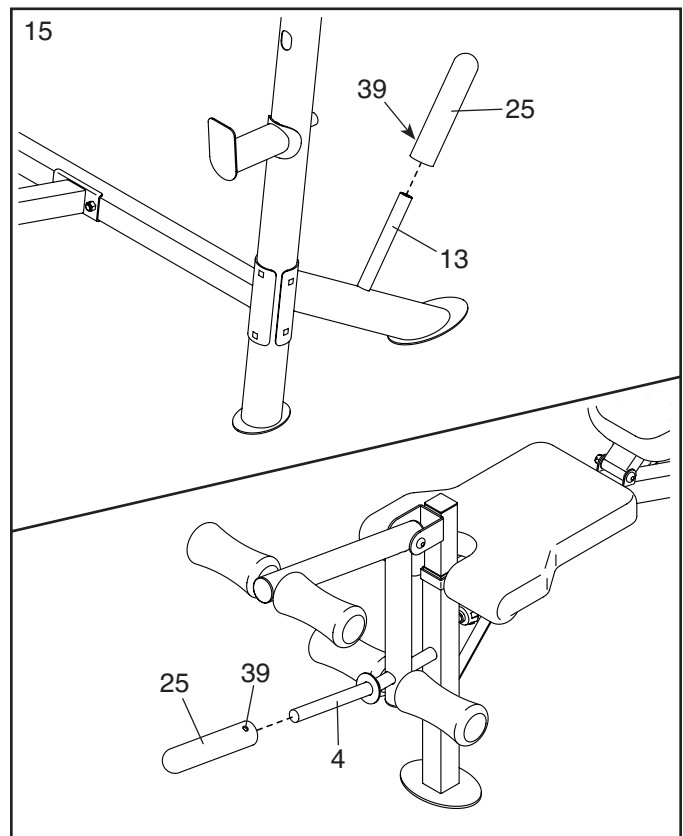

16. **Make sure that all parts are properly tightened before you use the weight bench.** Extra parts may be included. The use of all remaining parts will be explained in ADJUSTMENT, beginning on page 12.

# ADJUSTMENT

The steps below explain how the weight bench can be adjusted. See the accompanying exercise guide to see the correct form for several exercises.

Make sure that all parts are properly tightened each time you use the weight bench. Replace any worn parts immediately. The weight bench can be cleaned with a damp cloth and a mild, non-abrasive detergent; **do not use solvents.**

## ADJUSTING THE WEIGHT RESTS AND THE SPOTTERS

To adjust the height of the Weight Rests (29), first remove the Weight Rests from the Uprights (1), and then insert them into the desired adjustment holes in the Uprights. **Make sure that the Weight Rests are at the same height.**

To adjust the height of the Spotters (24), first remove the Spotters from the Uprights (1), and then insert them into the desired adjustment holes in the Uprights. **Make sure that the Spotters are at the same height.**

**⚠ WARNING:** Do not place more than 210 lbs. (92 kg) on the Weight Rests (29). Always place both Weight Rests at the same height and both Spotters (24) at the same height.

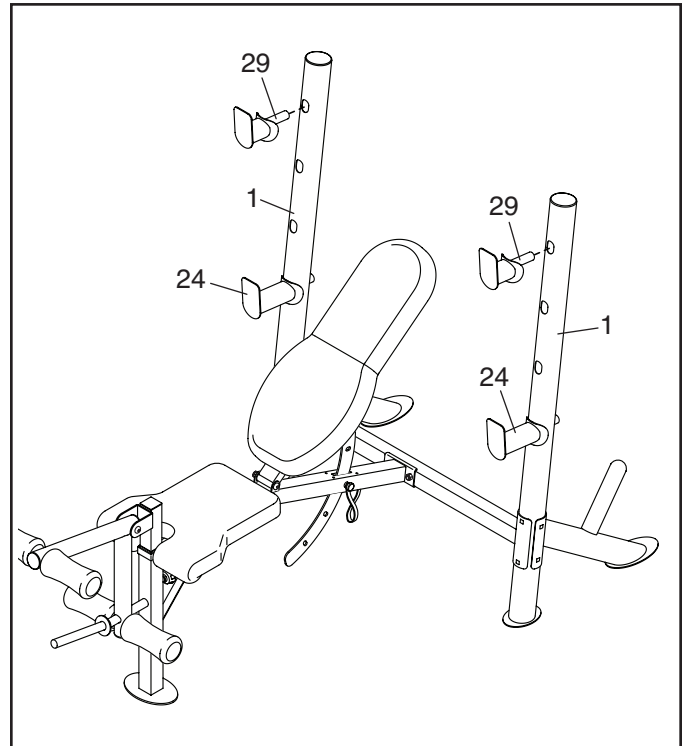

## ADJUSTING THE BACKREST

The Backrest (6) can be used in several positions. To adjust the position of the Backrest, remove the Locking Pin (36), move the Backrest to the desired position, and then insert the Locking Pin through the Seat Frame (2) into an adjustment hole in the Pivot Bracket (7).

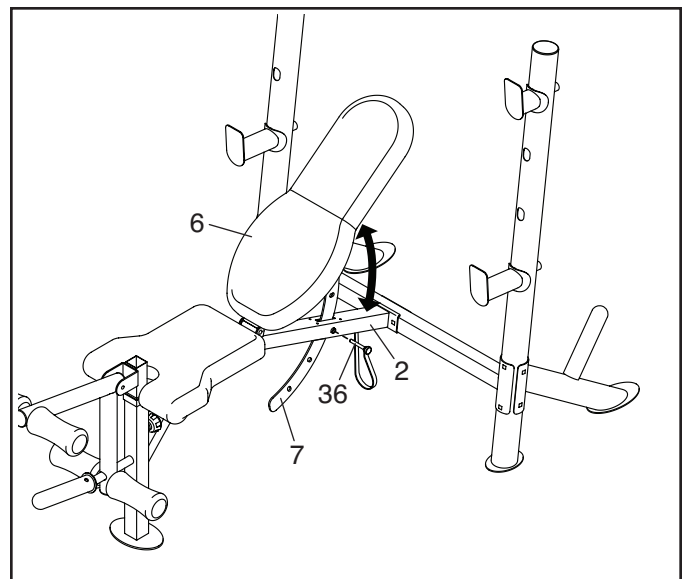

## ADJUSTING THE UPPER FRONT LEG

To adjust the height of the Upper Front Leg (27), first loosen and pull the Adjustment Knob (31) outward.

Move the Upper Front Leg (27) to the desired position, release the Adjustment Knob (31) into an adjustment hole in the Upper Front Leg, and then tighten the Adjustment Knob.

**When the Leg Lever (4) is not in use, remove the Upper Front Leg (27) and store it away from the weight bench.**

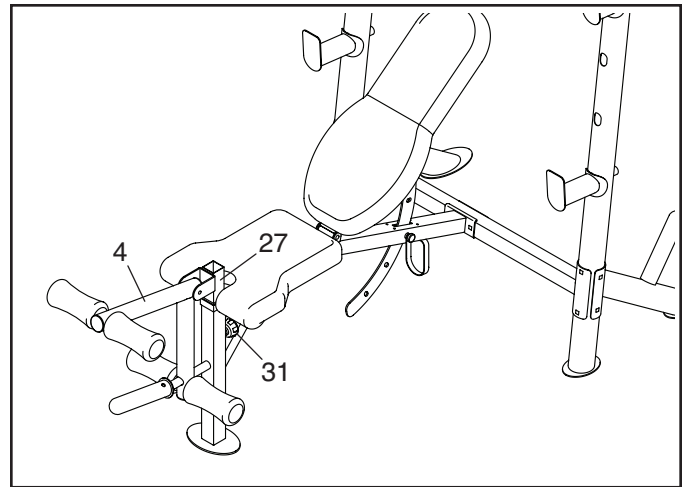

## ATTACHING WEIGHTS TO THE LEG LEVER

**If you plan to use Olympic weights (not included) with the weight bench, see assembly step 15 and attach the three Olympic Adapters (25) to the weight bench.**

To use the Leg Lever (4), slide the desired weights (not included) onto the weight tube on the Leg Lever. Secure the weights with the Spring Collar (45) or the Olympic Spring Collar (46).

**⚠ WARNING:** Do not place more than 130 lbs. (59 kg) on the Leg Lever (4).

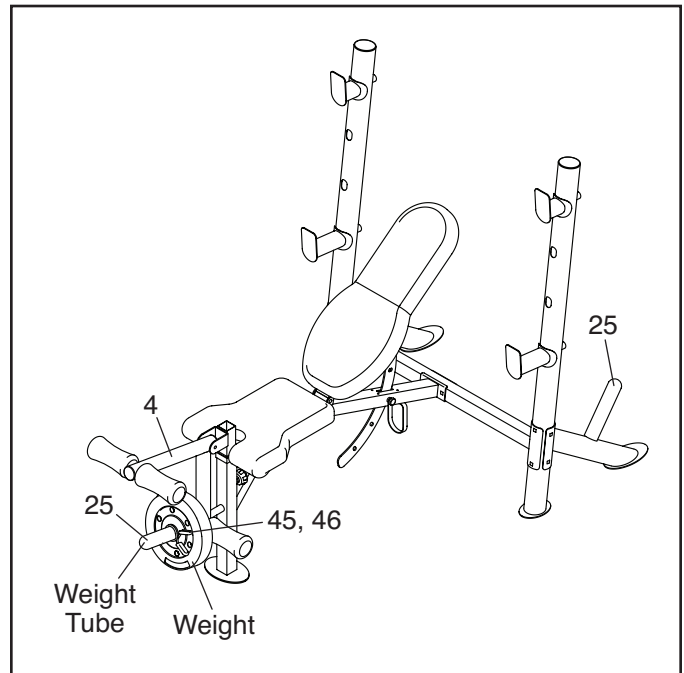

## STORING WEIGHTS

**If you plan to use Olympic weights (not included) with the weight bench, see assembly step 15 and attach the three Olympic Adapters (25) to the weight bench.**

Store weights (not included) by placing them on the weight storage tubes on the Left and Right Stabilizers (13, 38).

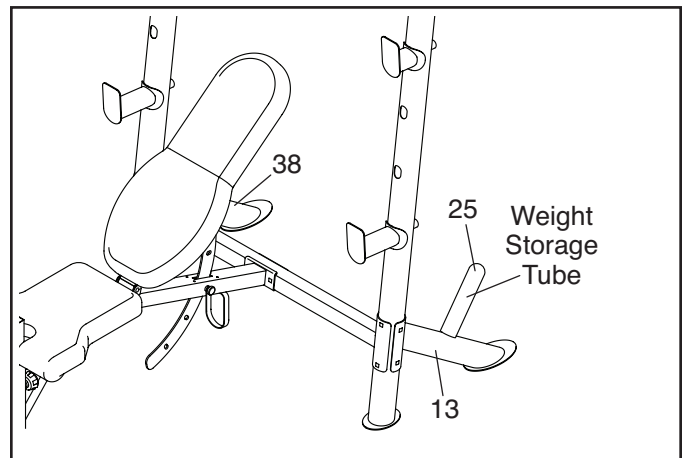

---

# EXERCISE GUIDELINES

## FOUR TYPES OF STRENGTH WORKOUTS

Note: A “repetition” is one complete cycle of an exercise, such as one sit-up. A “set” is a series of repetitions.

**Muscle Building**—Work your muscles near their maximum capacity and progressively increase the intensity of your exercise. Adjust the intensity level of an individual exercise as follows:

- Change the amount of resistance used.
- Change the number of repetitions or sets performed.

Use your own judgment to determine the amount of resistance that is right for you. Begin with 3 sets of 8 repetitions for each exercise you perform. Rest for 3 minutes after each set. When you can complete 3 sets of 12 repetitions without difficulty, increase the amount of resistance.

**Toning**—Tone your muscles by working them to a moderate percentage of their capacity. Select a moderate amount of resistance and increase the number of repetitions in each set. Complete as many sets of 15 to 20 repetitions as possible without discomfort. Rest for 1 minute after each set. Work your muscles by completing more sets rather than by using high amounts of resistance.

**Weight Loss**—To lose weight, use a low amount of resistance and increase the number of repetitions in each set. Exercise for 20 to 30 minutes, resting for a maximum of 30 seconds between sets.

**Cross Training**—Combine strength training and aerobic exercise by following this type of program:

- Strength training workouts on Monday, Wednesday, and Friday.
- 20 to 30 minutes of aerobic exercise on Tuesday and Thursday.
- One full day of rest each week to give your body time to regenerate.

## WORKOUT GUIDELINES

Familiarize yourself with the equipment and learn the proper form for each exercise. Use your own judgment to determine the appropriate length of time for each

workout, and the numbers of repetitions and sets to complete. Progress at your own pace and be sensitive to your body’s signals. Follow each workout with at least one day of rest.

**Warming Up**—Start with 5 to 10 minutes of stretching and light exercise. A warm-up increases your body temperature, heart rate, and circulation in preparation for exercise.

**Working Out**—Include 6 to 10 different exercises in each workout. Select exercises for every major muscle group, emphasizing areas that you want to develop. To give balance and variety to your workouts, vary the exercises from workout to workout.

**Cooling Down**—Finish with 5 to 10 minutes of stretching. Stretching increases the flexibility of your muscles and helps to prevent post-exercise problems.

## EXERCISE FORM

Move through the full range of motion for each exercise and move only the appropriate parts of the body. Perform the repetitions in each set smoothly and without pausing. The exertion stage of each repetition should last about half as long as the return stage. Exhale during the exertion stage of each repetition and inhale during the return stroke. Never hold your breath.

Rest for a short period of time after each set:

- Muscle Building—Rest for three minutes after each set.
- Toning—Rest for one minute after each set.
- Weight Loss—Rest for 30 seconds after each set.

## STAYING MOTIVATED

For motivation, keep a record of each workout. Write the date, the exercises performed, the resistance used, and the numbers of sets and repetitions completed. Record your weight and key body measurements once a month. To achieve good results, make exercise a regular and enjoyable part of your life.

**EXERCISE LOG**

Make copies of this page, and use the copies to schedule and record your strength and aerobic workouts. Scheduling and recording your workouts will help you to make exercise a regular and enjoyable part of your life.

**Strength**

Date:

\_\_\_\_ / \_\_\_\_ / \_\_\_\_

Exercise	Lbs.	Sets	Reps	Exercise	Lbs.	Sets	Reps
1.				6.			
2.				7.			
3.				8.			
4.				9.			
5.				10.			

**Aerobic**

Date:

\_\_\_\_ / \_\_\_\_ / \_\_\_\_

Exercise	Time	Distance	Speed

**Strength**

Date:

\_\_\_\_ / \_\_\_\_ / \_\_\_\_

Exercise	Lbs.	Sets	Reps	Exercise	Lbs.	Sets	Reps
1.				6.			
2.				7.			
3.				8.			
4.				9.			
5.				10.			

**Aerobic**

Date:

\_\_\_\_ / \_\_\_\_ / \_\_\_\_

Exercise	Time	Distance	Speed

**Strength**

Date:

\_\_\_\_ / \_\_\_\_ / \_\_\_\_

Exercise	Lbs.	Sets	Reps	Exercise	Lbs.	Sets	Reps
1.				6.			
2.				7.			
3.				8.			
4.				9.			
5.				10.			

**Aerobic**

Date:

\_\_\_\_ / \_\_\_\_ / \_\_\_\_

Exercise	Time	Distance	Speed

---

# NOTES



---

# NOTES

# PART LIST

Model No. 831.15964.0 R1015C

Key No.	Qty.	Description	Key No.	Qty.	Description
1	2	Upright	28	2	Backrest Frame Bushing
2	1	Seat Frame	29	2	Weight Rest
3	1	Crossbar	30	4	M6 x 40mm Screw
4	1	Leg Lever	31	1	Adjustment Knob
5	1	Backrest Frame	32	1	M10 x 75mm Bolt
6	1	Backrest	33	12	M10 Locknut
7	1	Pivot Bracket	34	2	M10 x 70mm Bolt
8	1	Lower Front Leg	35	6	Frame Cap
9	2	Round Cap	36	1	Locking Pin/Tether
10	2	Pad Tube	37	2	M8 x 20mm Screw
11	1	Seat	38	1	Right Stabilizer
12	1	Front Leg Cap	39	3	Set Screw
13	1	Left Stabilizer	40	1	M12 x 88mm Bolt
14	2	Storage Tube Cap	41	4	Foam Pad Cap
15	2	Upright Cap	42	4	Plug
16	2	M8 Washer	43	2	M8 x 80mm Bolt
17	2	M8 Locknut	44	1	Brace
18	8	M10 x 95mm Carriage Bolt	45	1	Spring Collar
19	1	Backrest Frame Cap	46	1	Olympic Spring Collar
20	1	Post Bushing	47	4	M10 x 20mm Bolt/Screw
21	3	Leg Lever Cap	48	2	M8 x 45mm Screw
22	1	Support Bracket	49	1	M12 Locknut
23	4	Foam Pad	50	3	M10 Washer
24	2	Spotter	51	1	M4 x 19mm Screw
25	3	Olympic Adapter	*	–	User's Manual
26	4	M6 Washer	*	–	Exercise Guide
27	1	Upper Front Leg	*	–	Grease Packet

Note: Specifications are subject to change without notice. For information about ordering replacement parts, see the back cover of this manual. **If a part is missing, call 1-877-992-5999.** \*These parts are not illustrated.



## Get it fixed, at your home or ours!

### Your Home

For repair—**in your home**—of **all** major brand appliances, lawn and garden equipment, or heating and cooling systems, **no matter who made it, no matter who sold it!**

For the replacement parts, accessories, and user's manuals that you need to do-it-yourself.

For Sears professional installation of home appliances and items like garage door openers and water heaters.

**1-800-4-MY-HOME® (1-800-469-4663)**

Call anytime, day or night (U.S.A. and Canada)

[www.sears.com](http://www.sears.com)

[www.sears.ca](http://www.sears.ca)

### Our Home

For repair of carry-in items like vacuums, lawn equipment, and electronics, call or go on-line for the location of your nearest **Sears Parts & Repair Center.**

**1-800-488-1222** Call anytime, day or night (U.S.A. only)

[www.sears.com](http://www.sears.com)

To purchase a protection agreement (U.S.A.) or maintenance agreement (Canada) on a product serviced by Sears:

**1-800-827-6655** (U.S.A.)

**1-800-361-6665** (Canada)

Para pedir servicio de reparación a domicilio, y para ordenar piezas:

**1-888-SU-HOGAR® (1-888-784-6427)**



® Registered Trademark / ™ Trademark / ™ Service Mark of Sears Brands, LLC  
® Marca Registrada / ™ Marca de Fábrica / ™ Marca de Servicio de Sears Brands, LLC

## 90 DAY FULL WARRANTY

If this Sears Weight Bench Exerciser fails due to a defect in material or workmanship within 90 days of the date of purchase, call 1-800-4-MY-HOME® (1-800-469-4663) to arrange for free repair (or replacement if repair proves impossible).

This warranty does not apply when the Weight Bench Exerciser is used commercially or for rental purposes. This warranty gives you specific legal rights, and you may also have other rights which vary from state to state.

**Sears, Roebuck and Co., Hoffman Estates, IL 60179**