



# AUTOMATIC WASHER INSTALLATION INSTRUCTIONS

---

---



***LEAVE THESE INSTRUCTIONS WITH THE OWNER***

## Read this before you start...

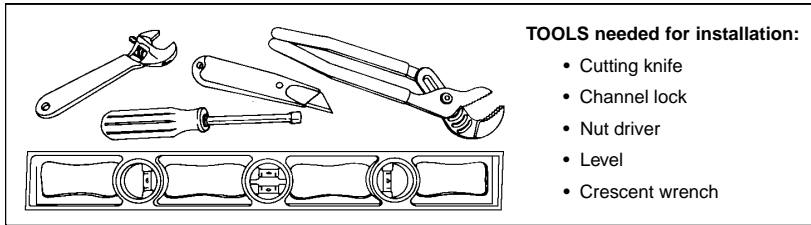

Proper installation is the responsibility of the purchaser.

**SERVICE CALLS PERFORMED AS A RESULT OF POOR INSTALLATION ARE THE RESPONSIBILITY OF THE INSTALLER.**

Make sure you have everything necessary for proper installation.

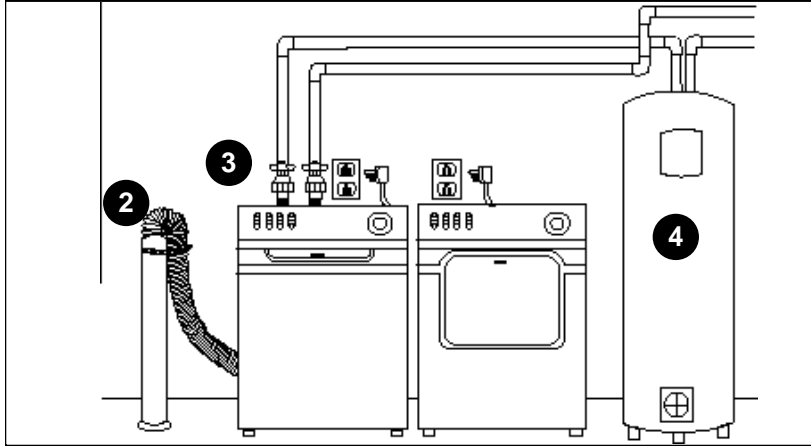

**1** GROUNDED ELECTRICAL OUTLETS are required. See Electrical Requirements.

**2** STANDPIPE DRAIN SYSTEM must be able to accept 1-1/2 inch O.D. drain hose. Standpipe height of 36 inches is recommended. The drain must permit 23 gallon per minute flow to evacuate the washer.

**NOTE:** If the standpipe height is less than 3 feet or greater than 5 feet, refer to the "DRAIN FACILITY" section to determine if special provisions are needed.

**3** HOT AND COLD WATER FAUCETS must be within 4 feet of the back of the washer.

**NOTE:** For installations requiring longer hose length, it is recommended to purchase a double male 3/4" NH coupling and Maytag hose #33-7046 or equivalent.



**4** WATER HEATER set to deliver 140°F (60°C) hot water to the washer.

**5** PROTECTION FROM WEATHER: Do not store or operate washer below 60°F (15°C).

### PARTS supplied for installation:

Cable tie to secure drain hose to standpipe, inlet hose or laundry tub



2 washers and 2 screens for water hoses



# REQUIREMENTS

---

## ELECTRICAL

120 Volt 60 Hz 15 AMP Fuse

Individual branch circuit serving only the washer is recommended.

The washer is equipped with a power cord.

**NEVER USE AN EXTENSION CORD.**

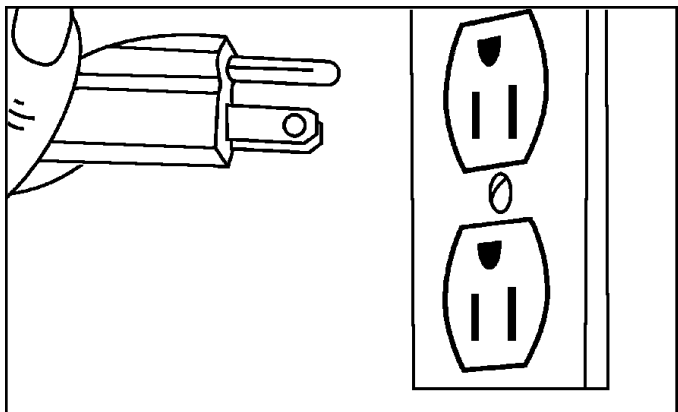

## EXPORT MODELS – 50 HZ AND 60 HZ

A washer must be used on the voltage and frequency it was designed for. It should be operated on an individual branch circuit and fused by no less than a 15 amp fuse or circuit breaker for 120 volt units or 10 amp fuse or circuit breaker on 220–240 volt units. Export models may require the addition of a plug on the power cord. It is the responsibility of the installer to assure that this has been done properly. Check the data plate to be sure of voltage and line frequency requirements.

## GROUNDING

***ELECTRICAL GROUND IS REQUIRED ON THIS APPLIANCE.***

Appliance is equipped with a power cord having a 3-prong grounding plug for use in a properly installed and grounded outlet.

### **Additional Ground Procedure:**

If a separate ground is required by local codes a grounding kit (Part No. 12001875) containing accessory ground wire, clamp, ground screw and washer can be purchased. Contact your authorized Maytag dealer for further assistance. Follow ALL grounding requirements and codes.

A proper external ground **MUST** be determined prior to wire hookup. Consult local building officials and a qualified electrician if in doubt.

**EXPORT**—specific grounding instructions must be determined due to variation of electrical services.

---

## WATER

Water pressure of 30 to 120 p.s.i. is required to correctly fill the washer to the proper levels. Pressures of less than 30 p.s.i. may cause a failure to the water valve. The valve might not shut off completely.

***TO AVOID THE POSSIBILITY OF WATER DAMAGE, SHOULD A HOSE LEAK, ALWAYS HAVE FAUCETS ACCESSIBLE AND TURN OFF FAUCETS WHEN WASHER IS NOT IN USE.***

## CABINET DIMENSIONS

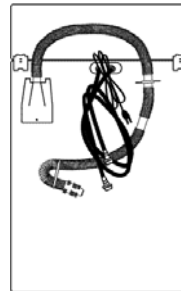
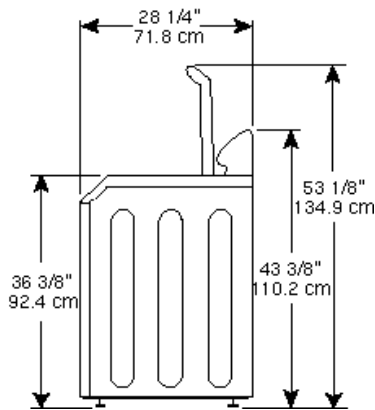

## DRAIN FACILITY

Recommended height of standpipe is 36". The standpipe must be large enough to accept a 1-1/2 inch outside diameter drain hose.

**Without the 36" high elevation, water may run out of the washer prematurely.** A possible sign that the drain hose has not been elevated to proper height is if the washer fills and drains at the same time.

The drain hose is attached at the factory.

A drain that will permit 23 gallons per minute flow is required to evacuate the washer. The standpipe should have a 1-1/2 inch minimum internal diameter to prevent siphoning.

Tight connections between the drain hose and the drain (standpipe, etc.) are not recommended since they violate most plumbing codes. In most cases where a tight connection is demanded, an antisiphon valve should be placed in the drain hose to prevent water from siphoning from the washer or facility during agitation. If required, an antisiphon valve (Part No. 12001586) is available from your dealer or store.

Refer to the drain height drawing to determine if special provisions must be taken for the drain hose and pump:

- (A)** Between the floor and 3 feet, the routing of the drain hose is critical. Be sure that at least some portion of the hose reaches a height of 3 feet before running to the drain.
- (B)** Between 3 feet and 5 feet is the recommended drain height.
- (C)** For drain heights greater than 5 feet, a high-volume pump (Part No. 12001587) may improve draining performance, especially if the unit provides a customized cycle with a slow spin speed (refer to the User's Guide).

If the drain hose needs to be extended to reach the drain facility, an accessory kit must be obtained (Part No. 12001585). If a high-volume pump is purchased, the extension kit is included. Contact your authorized Maytag dealer for further assistance.

## FLOORING

For best performance, the washer must be installed on a solidly constructed floor. Wood floors may need to be reinforced to minimize vibration and/or unbalanced load situations. Carpeting and soft tile surfaces are also contributing factors in vibration and/or tendency for a washer to move slightly during spin cycle. Never install washer on a platform or weak supported structure.

If installing on carpeting, be sure there is adequate clearance between carpet and moving parts beneath the washer.

## LOCATION CONSIDERATIONS

It is recommended the washer never be installed in areas where water may freeze, since the washer will always maintain some water in the water valve, pump and hose areas. This can cause damage to belts, pump, hoses and other components. Operating temperature should be above 60°F.

## COLD WEATHER STORAGE

The following precautions should be taken if a washer is to be stored where it would be subject to freezing conditions.

1. Turn off the water supply, and remove the inlet hoses.
2. Select a fill cycle and energize the water valve by selecting a warm water setting. A few seconds of fill is sufficient.
3. Disconnect from electrical supply.
4. Lower the drain hose to floor level and tip the washer on its back to allow water to drain from the pump and drain hose.
5. Return washer to upright position.
6. 30 day detergent dispenser should be completely emptied (on models so equipped).

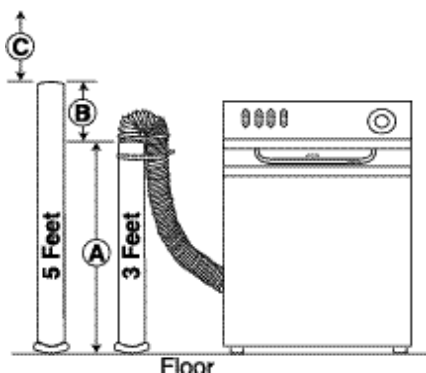

# Remove parts and literature from inside of washer

## Start here...

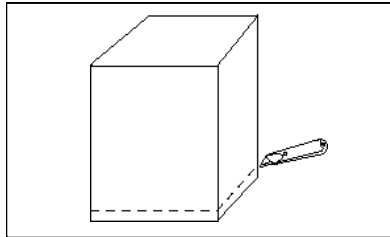

### Step 1

- Remove the carton by cutting only marked areas of the carton. **CAUTION: Hoses are connected to the washer.**

**NOTE:** If the washer is moved without the carton in place, be sure to keep sharp edges from damaging the washer cabinet or attached hoses.

- Lift the carton up and clear of the washer. Carefully remove any packaging materials from the outside of the washer. **NOTE: Retain the corner posts for later use.**
- Untape and raise the washer lid. Remove the styrofoam tub block, remove the items shipped in the spin basket, then replace the tub block. Save the literature for future reference. Close and tape lid.

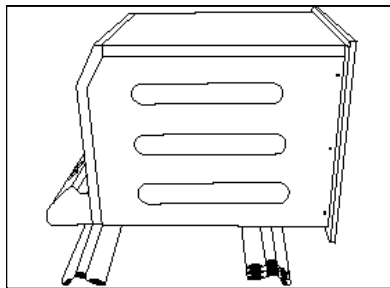

### Step 2

With the tub block in place and the lid taped shut, lay corner posts on the floor, as shown. Use one corner post to support the top, and three posts for the bottom. Gently tip the washer on its back, laying it across the corner posts.

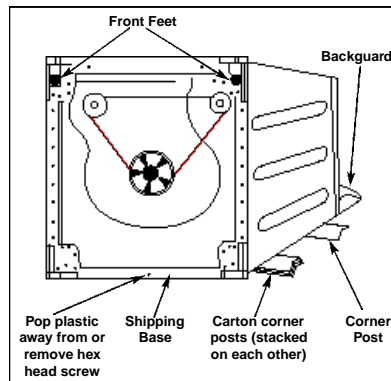

### Step 3

Pop the plastic shipping base away from the metal baseframe, or remove the hex head screw at the rear. Pull plastic base away from rear feet, and pull downward to disengage from front feet. Recycle or discard the plastic base. Return washer to upright position.

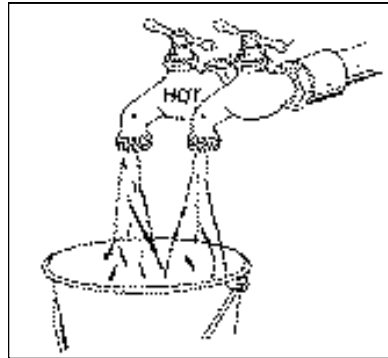

### Step 4

Run water through faucets to remove particles that might clog the water hoses. Determine which of the faucets is hot and place an identifying mark on it.

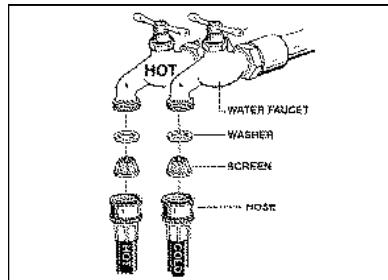

### Step 5

Water hoses are attached to the washer and labeled as "Hot" and "Cold." Push the screens and washers (located in the parts package) into the remaining ends of the hoses. Attach the "Hot" and "Cold" hoses to the corresponding faucets. Tighten by hand until snug and then an additional 2/3 turn with pliers. Turn on faucets to check for leaks at the faucet and machine. Tighten if necessary. Fill hoses should have slack in them when attached to faucets.

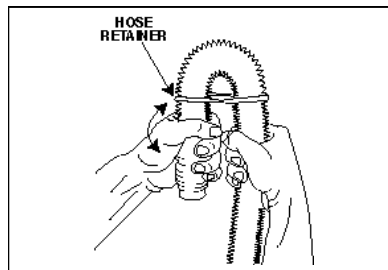

### Step 6

Unhook the hose retainer and drain hose from the back of the cabinet and place the drain hose in the drain facility (standpipe, laundry tub, etc.). A small amount of water may still be in the drain hose from factory testing. The height of the drain facility is important. Refer to the "DRAIN FACILITY" section to determine if special provisions are needed. **NOTE: Do not remove the hose retainer from the drain hose.** If the hose is twisted after it has been placed in the drain, adjust the end of the hose to remove the twist. To remove the twist, turn the short end of the hose while holding the base of the hose stationary.

**NOTE: If you must make an airtight seal, an antisiphon kit must be used.**

## ib. With the tub block in place, retape the lid. After in

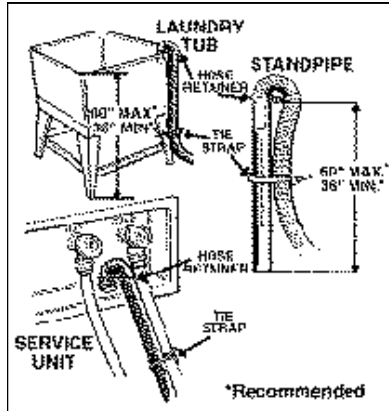

### Step 7

To prevent accidental dislodging, secure the drain hose to the standpipe, inlet hose, or laundry tub with the tie strap provided in the parts package.

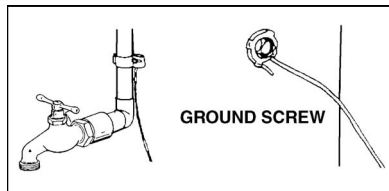

### Step 8

If separate ground is required by local codes:

An accessory grounding kit (Part No. 12001875) containing accessory ground wire, clamp, ground screw and washer can be purchased separately. Connect ground wire to back of unit with the cabinet ground screw and washer. Secure the other end of ground wire with clamp to grounded COLD metal water pipe.

NEVER CONNECT GROUND WIRE TO PLASTIC PLUMBING LINES, GAS LINES, OR HOT WATER PIPES.

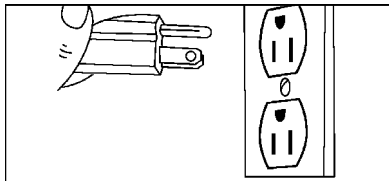

### Step 9

Plug the power cord into a properly grounded electrical outlet.

Consult local building officials and a qualified electrician if in doubt.



- Improper connection of the equipment-grounding conductor can result in a risk of electrical shock. Check with a qualified electrician or serviceman if you are in doubt as to whether the appliance is properly grounded.
- Do not modify the plug provided with the appliance – if it will not fit the outlet, have a proper outlet installed by a qualified electrician.

**IMPORTANT SAFETY PRECAUTIONS**

- To prevent unnecessary risk of fire, electrical shock or personal injury, all wiring and grounding must be done in accordance with the National Electrical Code ANSI/NFPA, No. 70-Latest Revision (for U.S.) or the Canadian Electrical code CSA C22.1-Latest Revision (for Canada) and local codes and ordinances. It is the personal responsibility and obligation of the appliance owner to provide adequate electrical services for this appliance.

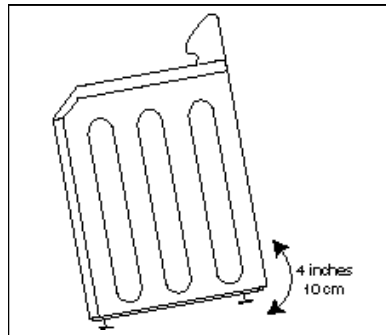

### Step 10

The washer is equipped with self-stabilizing rear legs. The front legs are threaded and can be adjusted to level the washer.

Place the washer in its final operating location. Tilt the machine forward until the rear of the machine is approximately 4 inches off the floor. Allow the unit to gently drop onto the rear feet. This causes the rear feet to conform to the floor and seat solidly.

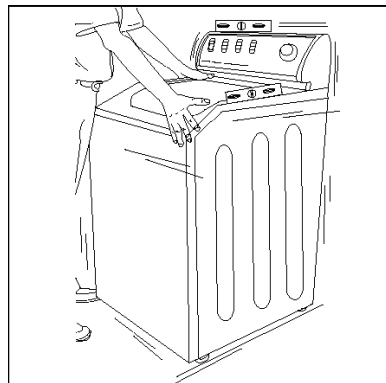

### Step 11

With hands on opposite corners, rock the washer to check for stability.

With a level, check the washer and make the necessary adjustments to the front leveling legs.

NOTE: Self-stabilizing rear legs level the rear of the machine side-to-side. They do not provide front-to-back leveling.

allation is completed, be sure to remove tub block.

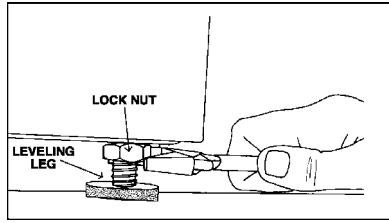

### Step 12

Once the machine is level, tighten both front leveling leg locking nuts with a wrench. Once again, reset the rear stabilizer as described in Step 10. On models equipped with a felt sound deflector under the front of the machine, the felt should be tucked under the machine.

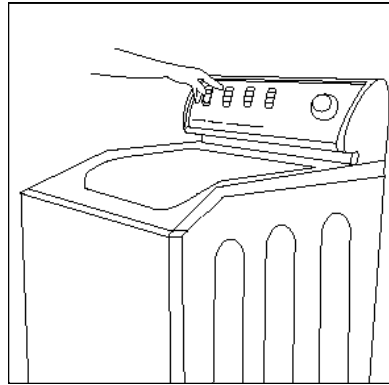

### Step 14

Check the operation by using the check list provided.

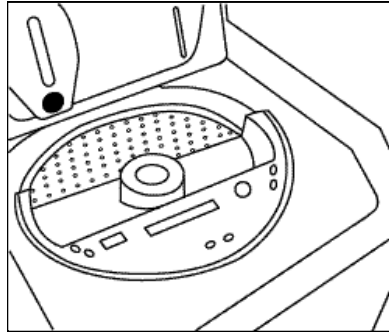

### Step 13

Remove tape from the lid. Open the lid to remove the styrofoam tub block. Remove any remaining shipping materials.

Remove the protective film from the fascia.

## CHECK LIST

- Tub block, parts package and instructions have been removed from the tub.
- Washer has been properly grounded and plugged into a polarized electrical outlet.
- Water has been turned on. Check for leaks at faucets and water valve connections.
- Drain hose is properly located into drain facility and is not twisted or kinked.
- Washer has been leveled with legs firmly on the floor. The front leveling legs' locking nuts have been tightened.
- Fill washer, checking for the correct water temperature.
- After the washer has filled, let the washer agitate.
- Spin the water out.
- Demonstrate washer usage to consumer. Be sure to leave these instructions and the User's Guide with the owner.