

Poulan PRO



OWNER'S MANUAL

MODEL NUMBER:
PR121ES
SNOW THROWER

⚠ WARNING:
Read the Owner's Manual and follow all Warnings and Safety Instructions. Failure to do so can result in serious injury.

Gasoline containing up to 10% ethanol (E10) is acceptable for use in this machine. The use of any gasoline exceeding 10% ethanol (E10) will void the product warranty.

Always Wear Eye Protection During Operation

CONGRATULATIONS on your purchase of a new snow thrower. It has been designed, engineered and manufactured to give best possible dependability and performance.

Should you experience any problem you cannot easily remedy, please contact your nearest authorized service center. We have competent, well-trained technicians and the proper tools to service or repair this unit.

Please read and retain this manual. The instructions will enable you to assemble and maintain your snow thrower properly. Always observe the "SAFETY RULES".

Safe Operation Practices for Walk-Behind Snow Throwers

IMPORTANT: This snow thrower is capable of amputating hands and feet and throwing objects. Failure to observe the following safety instructions could result in serious injury.



Look for this symbol  to point out important safety precautions. It means CAUTION!!! BECOME ALERT!!! YOUR SAFETY IS INVOLVED.





WARNING: Always disconnect spark plug wire and place it where it cannot contact plug in order to prevent accidental starting when setting up, transporting, adjusting or making repairs.



WARNING: This snow thrower is for use on sidewalks, driveways and other ground level surfaces. Caution should be exercised while using on sloping surfaces. Do not use snow thrower on surfaces above ground level such as roofs of residences, garages, porches or other such structures or buildings.



WARNING: Snow throwers have exposed rotating parts, which can cause severe injury from contact, or from material thrown from the discharge chute. Keep the area of operation clear of all persons, small children and pets at all times including startup.

CAUTION: Muffler and other engine parts become extremely hot during operation and remain hot after engine has stopped. To avoid severe burns on contact, stay away from these areas.



WARNING: Engine exhaust, some of its constituents, and certain vehicle components contain or emit chemicals known to the State of California to cause cancer and birth defects or other reproductive harm.

Training

1. Read, understand and follow all instructions on the machine and in the manual(s) before operating this unit. Be thoroughly familiar with the controls and the proper use of the equipment. Know how to stop the unit and disengage the controls quickly.
2. Never allow children to operate the equipment. Never allow adults to operate the equipment without proper instruction.
3. Keep the area of operation clear of all persons, particularly small children.
4. Exercise caution to avoid slipping or falling, especially when operating the snow thrower in reverse.

Preparation

1. Thoroughly inspect the area where the equipment is to be used and remove all doormats, sleds, boards, wires, and other foreign objects.
2. Ensure the control bar is released before starting the engine.
3. Do not operate the equipment without wearing adequate winter garments. Avoid loose fitting clothing that can get caught in moving parts. Wear footwear that will improve footing on slippery surfaces.
4. Handle fuel with care; it is highly flammable
 - (a) Use an approved fuel container.
 - (b) Never add fuel to a running engine or hot engine.

- (c) Fill fuel tank outdoors with extreme care. Never fill fuel tank indoors.
 - (d) Never fill containers inside a vehicle or on a truck or trailer bed with a plastic liner. Always place containers on the ground, away from your vehicle, before filling.
 - (e) When practical, remove gas-powered equipment from the truck or trailer and refuel it on the ground. If this is not possible, then refuel such equipment on a trailer with a portable container, rather than from a gasoline dispenser nozzle.
 - (f) Keep the nozzle in contact with the rim of the fuel tank or container opening at all times, until refueling is complete. Do not use a nozzle lock-open device.
 - (g) Replace gasoline cap securely and wipe up spilled fuel.
 - (h) If fuel is spilled on clothing, change clothing immediately.
5. Use extension cords and receptacles as specified by the manufacturer for all units with electric drive motors or electric starting motors.
 6. Never attempt to make any adjustments while the engine (motor) is running (except when specifically recommended by manufacturer).
 7. Always wear safety glasses or eye shields during operation or while performing an adjustment or repair to protect eyes from foreign objects that may be thrown from the machine.
 8. Use ear protectors to avoid damage to hearing.

Operation

1. Do not put hands or feet near or under rotating parts. Keep clear of the discharge opening at all times.
2. Exercise extreme caution when operating on or crossing gravel drives, walks, or roads. Stay alert for hidden hazards or traffic.
3. After striking a foreign object, stop the engine (motor), disconnect the cord on electric motors, thoroughly inspect the snow thrower for any damage, and repair the damage before restarting and operating the snow thrower. Remove key.
4. If the unit should start to vibrate abnormally, stop the engine (motor) and check immediately for the cause. Vibration is generally a warning of trouble.
5. Stop the engine (motor) whenever you leave the operating position, before unclogging the auger housing or discharge chute, and when making any repairs, adjustments or inspections.
6. When cleaning, repairing or inspecting the snow thrower, stop the engine and make certain the auger blades and all moving parts have stopped. Remove key.
7. Do not run the engine indoors, except when starting the engine and for transporting the snow thrower in or out of the building. Open the outside doors; exhaust fumes are dangerous.
8. Exercise extreme caution when operating on slopes.
9. Never operate the snow thrower without proper guards, and other safety protective devices in place and working.
10. Never direct the discharge toward people or areas where property damage can occur. Keep children and others away.
11. Do not overload the machine capacity by attempting to clear snow at too fast a rate.
12. Never operate the machine at high transport speeds on slippery surfaces. Look behind and use care when operating in reverse.
13. Disengage power to the auger blades when snow thrower is transported or not in use.
14. Use only attachments and accessories approved by the manufacturer of the snow thrower.
15. Never operate the snow thrower without good visibility or light. Always be sure of your footing, and keep a firm hold on the handles. Walk; never run.
16. Never touch a hot engine or muffler.

Clearing a Clogged Discharge Chute



Hand contact with the rotating auger blades inside the discharge chute is the most common cause of injury associated with snow throwers. Never use your hand to clean out the discharge chute.

To clear the chute:

1. SHUT THE ENGINE OFF!
2. Wait 10 seconds to be sure the auger blades have stopped rotating.
3. Always use a clearing tool at least 15 inches long.

Maintenance and Storage

1. Check shear bolts and other bolts at frequent intervals for proper tightness to be sure the equipment is in safe working condition.
2. Never store the machine with fuel in the fuel tank inside a building where ignition sources are present such as hot water heaters, space heaters, or clothes dryers. Allow the engine to cool before storing in any enclosure.
3. Always refer to operator's manual for important details if the snow thrower is to be stored for an extended period.
4. Maintain or replace safety and instruction labels, as necessary.
5. Run the machine a few minutes after throwing snow to prevent freeze-up of the collector/impeller.

SERIAL NUMBER: _____

DATE OF PURCHASE: _____

THE MODEL AND SERIAL NUMBERS WILL BE FOUND ON A DECAL ATTACHED TO THE REAR OF THE SNOW THROWER HOUSING (Figure 1).

YOU SHOULD RECORD BOTH SERIAL NUMBER AND DATE OF PURCHASE AND KEEP IN A SAFE PLACE FOR FUTURE REFERENCE.

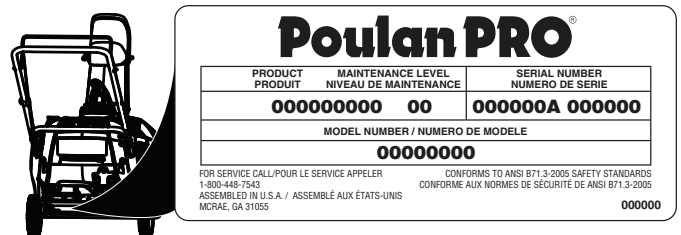

Figure 1

CUSTOMER RESPONSIBILITIES

- Read and observe the safety rules.
- Follow a regular schedule in maintaining, caring for and using your snow thrower.
- Follow the instructions under "Maintenance" and "Storage" sections of this manual.

PRODUCT SPECIFICATIONS

Gasoline Capacity and Type:	0.4 Gallons (1,4 Liters) Unleaded Regular only
Oil Type (API SG-SL):	SAE 30 (above 50°F) SAE 5W-30 or 10W-30 (32° to 50°F) SAE 5W-30 (below 32°F)
Oil Capacity:	16 Ounces (0,47 Liters)
Spark Plug: Gap:	F6RTC 0.030" (0,762 mm)

TABLE OF CONTENTS

SAFETY RULES	2-3	OPERATION	7-11
PRODUCT SPECIFICATIONS.....	3	MAINTENANCE	12-15
CUSTOMER RESPONSIBILITIES.....	3	STORAGE.....	16
SAFETY AND INSTRUCTIONAL DECALS	4	TROUBLESHOOTING	17
SETUP.....	5-6	REPAIR PARTS.....	18-27
PRODUCT OVERVIEW	6		

KNOW YOUR SNOW THROWER

READ THIS OWNER'S MANUAL AND ALL SAFETY RULES BEFORE OPERATING YOUR SNOW THROWER.

Compare the illustrations with your snow thrower to familiarize yourself with the location of various controls and adjustments. Save this manual for future reference.

These symbols may appear on your snow thrower or in literature supplied with the product. Learn and understand their meaning.

IMPORTANT: Safety and instruction decals are located near areas of potential danger. Replace damaged decals.

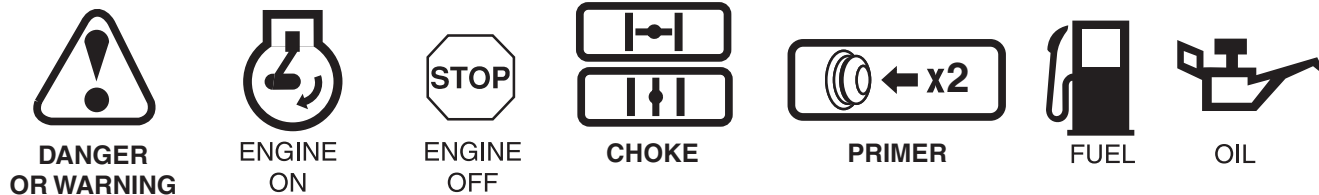

DANGER OR WARNING

ENGINE ON

ENGINE OFF

CHOKE

PRIMER

FUEL

OIL



READ AND FOLLOW ALL SAFETY INFORMATION AND INSTRUCTIONS BEFORE USE OF THIS PRODUCT. KEEP THESE INSTRUCTIONS FOR FUTURE REFERENCE.



EAR PROTECTION RECOMMENDED



IGNITION KEY. INSERT TO START AND RUN, PULL OUT TO STOP.

⚠ DANGER

Shut off engine before unclogging chute. A clean-out tool must be used. Never use your hand to unclog chute.
Les blocages ne doivent pas être dégagés jusqu'à ce que le moteur soit au point mort. Utilisez un outil pour nettoyage. N'utilisez jamais vos mains pour nettoyer les chutes.

⚠ DANGER

TO AVOID INJURY FROM ROTATING AUGER - KEEP HANDS, FEET AND CLOTHING AWAY.

POUR ÉVITER DES BLESSURES SÉRIEUSES AVEC LA FOREUSE TOURNANTE - GARDEZ LES MAINS, LES PIEDS ET LES VÊTEMENTS LOIN.

⚠ DANGER

<ul style="list-style-type: none"> • Read and follow owner's manual. • Never allow children to operate snowthrower. • Keep all shields and guards in place while operating. • Shut off engine and remain behind handles until all moving parts have stopped before unclogging or servicing unit. • To avoid thrown object injuries never direct discharge at bystanders. Use extra caution when operating on gravel surfaces. 	<ul style="list-style-type: none"> • Lisez le manuel du propriétaire. • N'autorisez jamais que le enfants utilisent le chasse - neige. • Gardez tous les déflecteurs en place pendant l'utilisation. • Arrêtez le moteur et restez derrière des guidons jusqu'à ce que toutes les pièces mobiles se soient arrêtées avant de déboucher ou de faire aucun entretien à l'unité. • Pour éviter des blessures sérieuses d'objets projetés; soyez conscient que l'orientation de la décharge ne soit jamais dirigée aux spectateurs. Prenez des précautions particulières quand vous allez sur des surfaces de gravier.
---	---

←→ START
RUN |↑|

Setup

Loose Parts

Use the chart below to verify that all parts have been shipped.

Procedure	Description	Qty.	Use
1.	No parts required	–	Unfold the handle.
2.	Carriage bolts Shoulder Bolt Flange nuts Washer Knob Cap Plunger Chute Deflector	4 1 4 1 1 1 1 1 1	Install the discharge chute. Install the discharge chute. Install the discharge chute. Install the discharge chute. Install the discharge chute. Install the discharge chute. Install the discharge chute. Install the discharge chute. Install the discharge chute.

1. Unfolding the Handle

Procedure

- Loosen the two handle knobs and pull out the two handle bolts until you can move the handle freely and rotate the handle to the operating position (Figure 2).

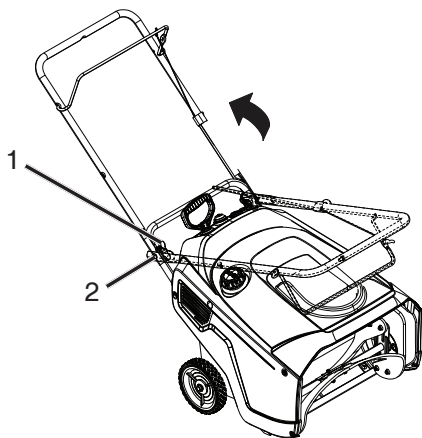

Figure 2

1. Handle knobs 2. Handle bolt

- Tighten the handle knobs until they are snug (Figure 3).

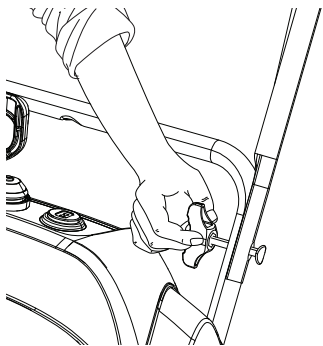

Figure 3

2. Installing the Discharge Chute

Procedure

- Install the chute deflector to the discharge chute using bolts and, washer, nut, deflector knob and cap plunger (Figure 4).
- Install the discharge chute to the chute base using three screws and nuts.

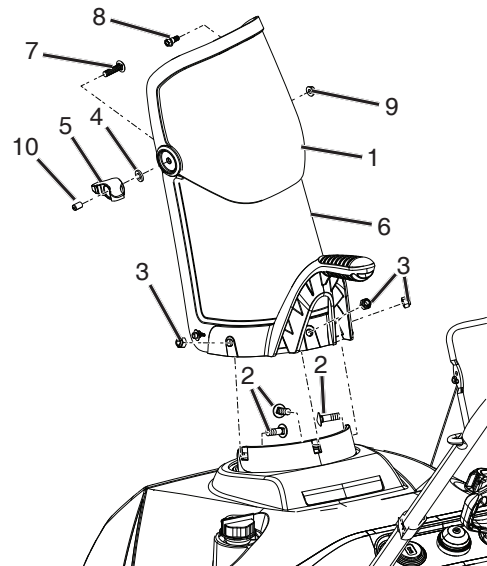

Figure 4

- | | |
|------------------------|-----------------------|
| 1. Deflector | 6. Discharge chute |
| 2. Carriage bolts | 7. Carriage Bolt |
| 3. Flange nuts 5/16-18 | 8. Shoulder Bolt |
| 4. Washer | 9. Flange nuts 1/4-20 |
| 5. Knob | 10. Cap Plunger |

IMPORTANT: Do not overtighten the flange nuts; otherwise you may damage the discharge chute.

3. Filling the Engine with Oil

ENGINE

See engine manual.

LUBRICATION

NOTE: SAE 10W30 or SAE 5W30 oil is acceptable for use in cold temperatures if engine is difficult to start.

NOTE: Although multi-viscosity oils (5W30, 10W30 etc.) improve starting in cold weather, these multi-viscosity oils will result in increased oil consumption when used above 32°F. Check your engine oil level more frequently to avoid possible engine damage from running low on oil.

Change the oil after every 25 hours of operation or at least once a year if the snow thrower is not used for 25 hours in one year.

Check the crankcase oil level before starting the engine and after each five (5) hours of continuous use. Tighten oil fill cap / dipstick securely each time you check the oil level.

1. Move the snowthrower to a level surface.
2. Clean around the dipstick (Figure 5).

NOTE: Dipstick location may vary depending on engine type.

3. Remove either side mounted filler cap dipstick or high oil fill dipstick and wipe it clean.

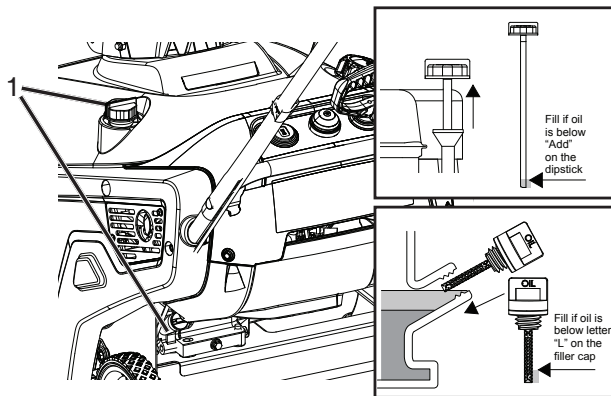

Figure 5

1. Oil filler cap/dipstick

4. Insert the dipstick into the filler neck and turn clockwise until fully seated. Then remove the dipstick by turning it counter-clockwise.
5. Fill oil to "FULL" on dipstick with the recommended oil.
6. Securely screw in the oil filler cap/dipstick.

Product Overview

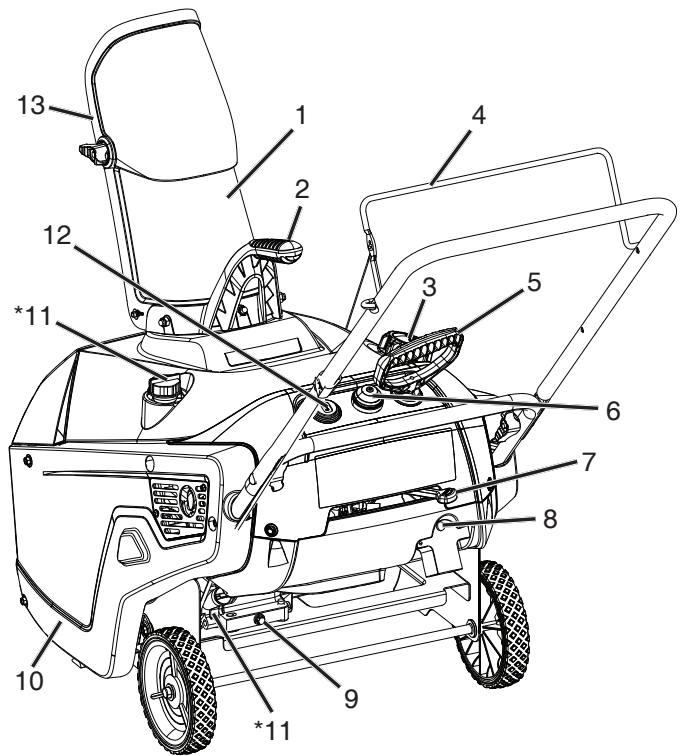



Figure 6

- | | |
|---------------------------|--|
| 1. Discharge chute | 8. Electric-start button (if equipped) |
| 2. Chute deflector handle | 9. Oil drain plug |
| 3. Fuel tank cap | 10. Drive belt cover |
| 4. Control bar | *11. Oil fill cap/dipstick |
| 5. Recoil start handle | 12. Ignition key |
| 6. Primer | 13. Chute deflector |
| 7. Choke lever | |

* Dipstick location may vary depending on engine type.

Operation

NOTE: Determine the left and right sides of the machine from the normal operating position.



- **Gasoline is extremely flammable and explosive. A fire or explosion from gasoline can burn you and others.**
- **To prevent a static charge from igniting the gasoline, place the container and/or snowthrower on the ground before filling, not in a vehicle or on an object.**
- **Fill the tank outdoors when the engine is cold. Wipe up spills.**
- **Do not handle gasoline when smoking or around an open flame or sparks.**
- **Store gasoline in an approved fuel container, out of the reach of children.**
- **Do not tip the snowthrower with fuel in the fuel tank.**



The operation of any snow thrower can result in foreign objects thrown into the eyes, which can result in severe eye damage. Always wear safety glasses or eye shields while operating your snow thrower or performing any adjustments or repairs. We recommend standard safety glasses or a wide vision safety mask worn over spectacles.

IMPORTANT: Know how to operate all controls before adding fuel or attempting to start the engine.

Filling the Fuel Tank

Fill the fuel tank with fresh, unleaded gasoline (minimum 87 AKI octane rating) (Figure 7).

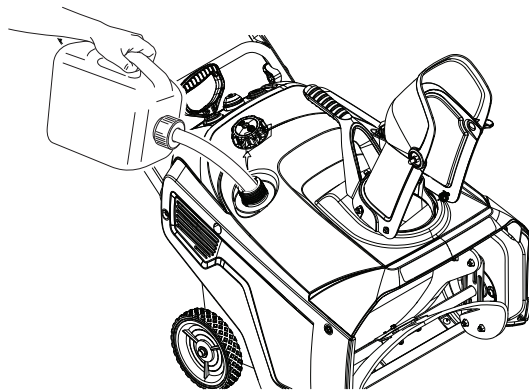

Figure 7

IMPORTANT: Do not add oil to the gasoline.

IMPORTANT: Do not use E85 blended fuels. This engine is not E20/E30/E85 compatible. Alternative fuels with high alcohol content can cause hard starting, poor engine performance, and may cause internal engine damage.

NOTE: For best results, purchase only the quantity of gasoline that you expect to use in 30 days. Otherwise, you may add fuel stabilizer to newly purchased gasoline to keep it fresh for up to 6 months.

Checking the Engine Oil Level

1. Move the snowthrower to a level surface.
2. Clean around the dipstick (Figure 8).

NOTE: Dipstick location may vary depending on engine type.

3. Remove either side mounted filler cap dipstick or high oil fill dipstick and wipe it clean.

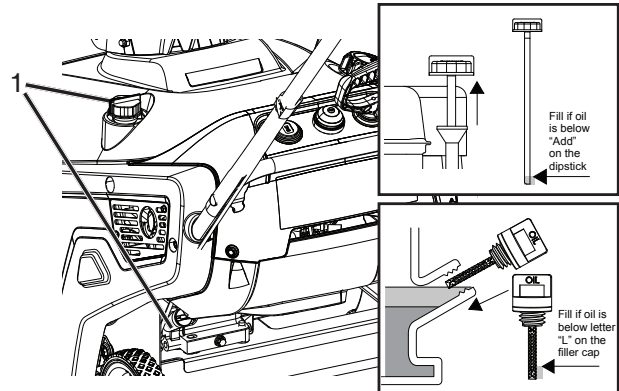

Figure 8

1. Oil filler cap/dipstick

4. Insert the dipstick into the filler neck and turn clockwise until fully seated. Then remove the dipstick by turning it counter-clockwise.
5. Fill oil to "FULL" on dipstick with the recommended oil.
6. Securely screw in the oil filler cap/dipstick.

NOTE: Running the engine with a low oil level can cause engine damage. Always check the engine oil before start up.

NOTE: Running the engine with too much oil may cause engine damage and excess smoke in the exhaust. Always check the engine oil level before start up.

Starting the Engine

1. Push key in (Figure 9).

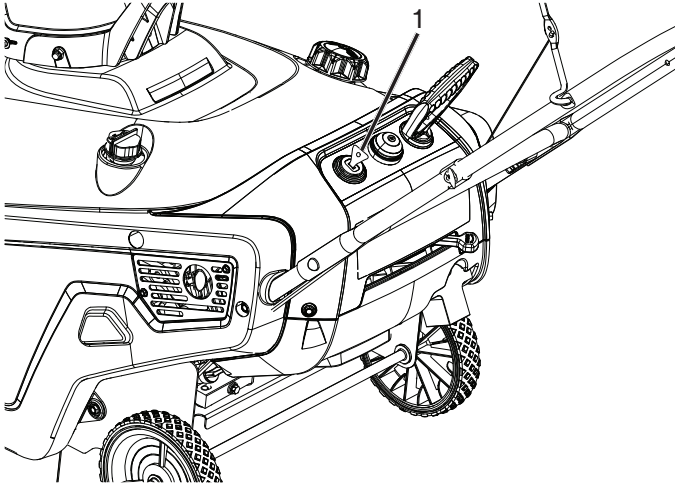

Figure 9

1. Key

2. Move choke lever to left position (Figure 10).

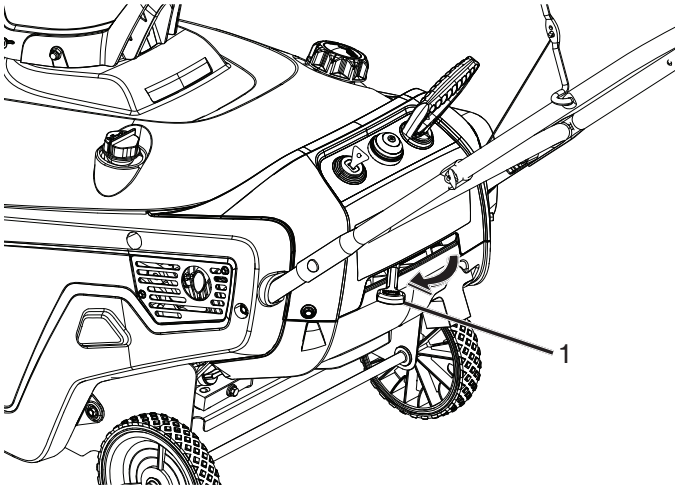

Figure 10

1. Choke lever

3. Firmly push in the primer 2 times with your thumb, holding the primer in a for a second before releasing it each time (Figure 11).

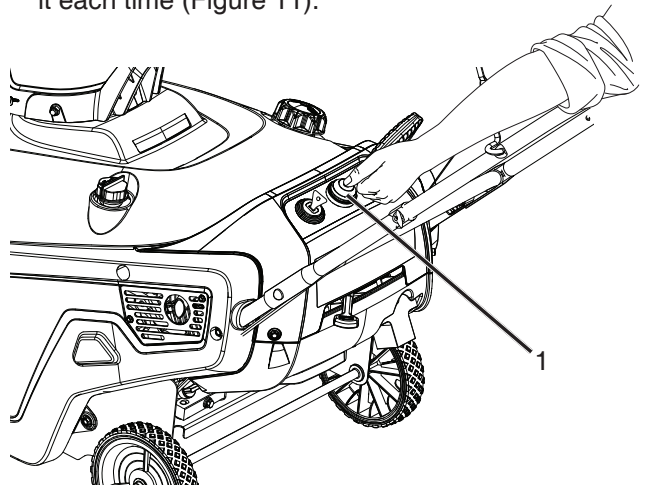

Figure 11

1. Primer

NOTE: Remove your glove when you push in the primer so that air cannot escape from the primer hole.

IMPORTANT: It may not be necessary to use the primer or the choke if the engine has been running and is hot. Excessive priming may flood the engine and prevent it from starting.

4. Pull the recoil starter (Figure 12) or if your snow thrower is equipped with an electric starter, connect an extension cord to the snow thrower and plug the other end into a three-hole grounded 110 volt A.C. receptacle and push the electric-start button (Figure 13).



Figure 12

1. Recoil start handle

NOTE: Use only a UL-listed, 16-gauge extension cord recommended for outdoor use that is not longer than 50 feet (15 m).



The electrical cord can become damaged, causing a shock or fire.

Thoroughly inspect the electrical cord before plugging it into a power source. If the cord is damaged, do not use it to start the snowthrower. Replace or repair the damaged cord immediately. Contact an Authorized Service Dealer for assistance.

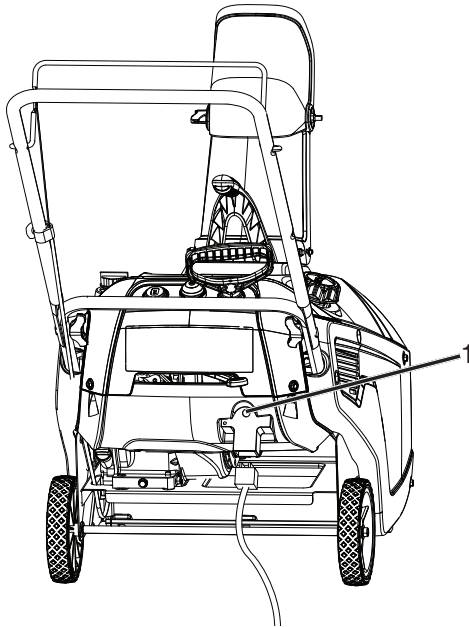

Figure 13

1. Electric start button

IMPORTANT: Run the electric starter no more than 10 times at intervals of 5 seconds on, then 5 seconds off. Running the electric starter extensively can overheat and damage it. If the engine does not start after this series of attempts, wait at least 40 minutes to allow the starter to cool before attempting to start it again. If the engine does not start after the second series of attempts, take the snowthrower to an Authorized Service Dealer for service.

NOTE: If you pull the recoil handle and feel no resistance, the starter may be frozen. Thaw out the starter before attempting to start the snowthrower.

5. While the engine is running, move the choke lever slowly to the right position.
6. Unplug the extension cord from the power source and the snowthrower (Figure 13).



Unplug the power cord whenever you are not starting the snowthrower.

Engaging the Auger Blades

1. To engage the auger blades, hold the control bar against the handle (Figure 14).



Figure 14

1. Control bar

Disengaging the Auger Blades

1. To disengage the auger blades, release the control bar (Figure 15).



Figure 15

1. Control bar

IMPORTANT: During initial operation there is wear between the auger blades and the scraper bar. This wear is normal and to be expected. Maximum performance, both snow throwing and driving, occurs when there is zero clearance between these two parts. In order to account for part variation a small interference is designed into the parts so they can wear to zero clearance within the first few minutes of operation (Figure 16).



During initial break-in period of the auger blades it is normal for the auger blades to build up excessive heat if not operated in the snow.

Do not operate without snow or water for lubricating the auger blades. This will cause excessive heat build up in the auger blades which could cause damage to the auger blades and scraper bar.

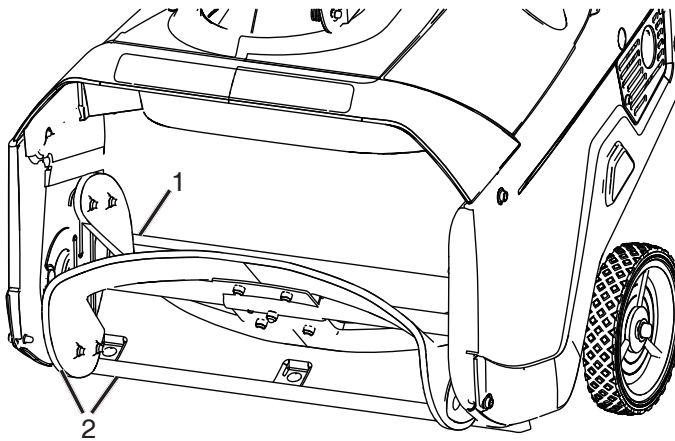

Figure 16

1. Rub Area

2. Wear Areas

Adjusting the Discharge Chute and Chute Deflector

1. To adjust the discharge chute, move deflector chute handle left or right to desired position (Figure 18).

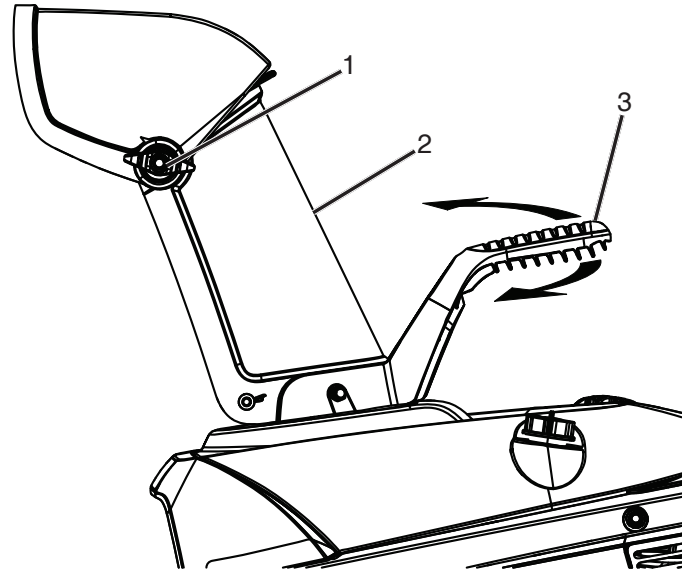

Figure 18

1. Chute deflector knob

2. Chute deflector

3. Chute handle

2. To raise or lower the angle of the chute deflector, loosen the chute deflector knob on the chute deflector and move the chute deflector up or down (Figure 18).

Stopping the Engine

To stop the engine, pull key out (Figure 17).

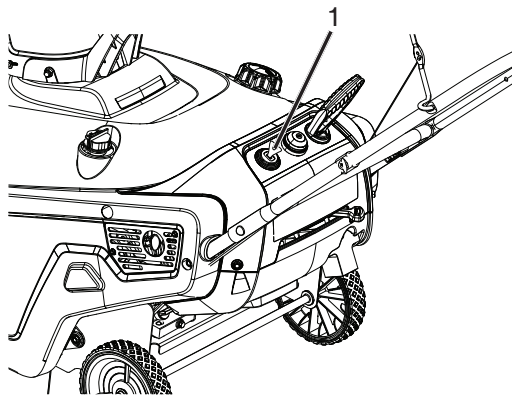

Figure 17

1. Key

Clearing a Clogged Discharge Chute



Hand contact with the rotating auger blades inside the discharge chute is the most common cause of injury associated with snow throwers. Never use your hand to clean out the discharge chute.

To clear the chute:

1. SHUT THE ENGINE OFF!
2. Wait 10 seconds to be sure the auger blades have stopped rotating.
3. Always use a clearing tool at least 15 inches long, not your hands (Figure 19).



Figure 19

Preventing Freeze-up After Use

- Let the engine run for a few minutes to prevent moving parts from freezing. Stop the engine, wait for all moving parts to stop, and remove ice and snow from the snowthrower.
- Clean off any snow and ice from the base of the chute.
- Rotate the discharge chute left and right to free it from any ice buildup.
- With the ignition key in the Off position, pull the recoil starter handle several times or connect the electrical cord to a power source and the snowthrower and push the electric start button once to prevent the recoil starter and/or the electric starter from freezing up.
- In snowy and cold conditions, some controls and moving parts may freeze. Do not use excessive force when trying to operate frozen controls. If you have difficulty operating any control or part, start the engine and let it run for a few minutes.

Operating Tips



The auger blades can throw stones, toys, and other foreign objects and cause serious personal injury to the operator or to bystanders.

- **Keep the area to be cleared free of all objects that the auger blades could pick up and throw.**
 - **Keep all children and pets away from the area of operation.**
 - **Do not operate snow thrower if weather conditions impair visibility. Throwing snow during a heavy, windy snowstorm can blind you and be hazardous to the safe operation of the snow thrower.**
- The best time to remove snow is the early morning. At this time the snow is usually dry and has not been exposed to the direct sun and warming temperatures.
 - Slightly overlap each successive path to ensure all snow will be removed.
 - Throw snow downwind whenever possible.
 - For extremely heavy snow, reduce the width of snow removal by overlapping previous path and moving slowly.
 - Keep engine clean and clear of snow during use. This will help air flow and extend engine life.
 - After snow-throwing is completed, allow engine to run for a few minutes to melt snow and ice off the engine.
 - Clean the entire snow thrower thoroughly after each use and wipe dry so it is ready for next use.
 - Spraying off unit with a hose is NOT recommended.

Maintenance

NOTE: Determine the left and right sides of the machine from the normal operating position.

MAINTENANCE SCHEDULE						SERVICE DATES							
		BEFORE EACH USE	AFTER EACH USE	EVERY 25 HOURS OR EVERY SEASON	BEFORE STORAGE								
T H R O W E R	Check for Loose Fasteners	✓			✓								
	Clean / Inspect Snow Thrower		✓		✓								
	Clean / Replace V-Belts			✓									
	Check / Replace Auger Blades and Scraper Bar	✓											
	Check Fuel Lines and Electrical Wires			✓	✓								
E N G I N E	Check Engine Oil Level	✓											
	Change Engine Oil			✓									
	Inspect Muffler			✓									
	Check / Replace Spark Plug			✓									
	Empty Fuel Tank				✓								

Adjusting the Control Cable

Checking the Control Cable

1. Release the control bar to remove the slack in the control cable (Figure 20).



Figure 20

1. Control bar

IMPORTANT: The control cable must contain some slack when you disengage the control bar for the auger blades to stop properly.

NOTE: You may need to adjust the control cable from position 1 (default) to position 2 if you notice belt slip when the control bar is engaged.

NOTE: If the control cable is adjusted to position 2, ensure that the auger stops properly when the control bar is released

Adjusting the Control Cable

1. With the control bar disengaged, unhook and move the control cable to the highest position. (Figure 21).

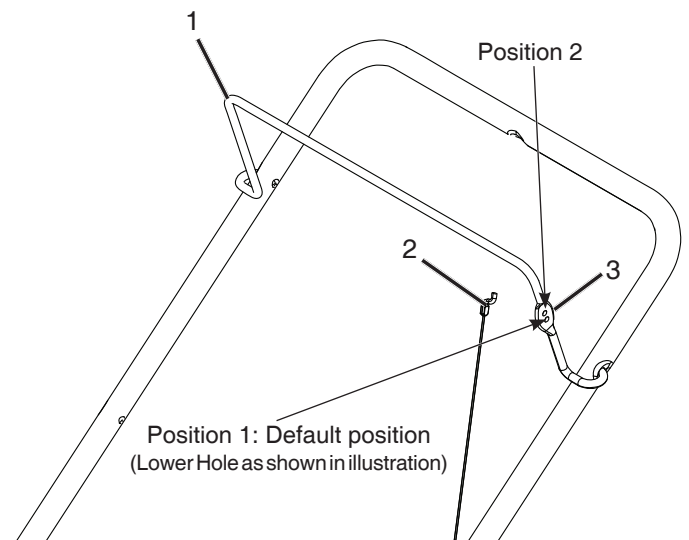

Figure 21

1. Control bar
2. Adjuster link
3. Cable positions

Inspecting the Auger Blades/ Scraper Bar

Before each session, inspect the auger blades for wear. When an auger blade edge or the scraper bar has worn down have an Authorized Service Dealer replace the auger blades and the scraper bar (Figure 22).

NOTE: Auger blades and scraper bar are wear items and may have to be replaced after extended use.

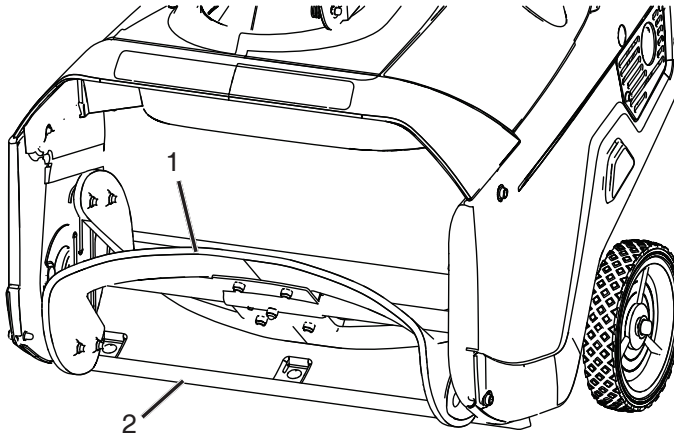

Figure 22

1. Auger blades 2. Scraper bar

Changing the Engine Oil

Run the engine a few minutes before changing the oil to warm it. Warm oil flows better and carries more contaminants.



The engine oil will be hot. Avoid skin contact with the used engine oil.

1. Move snowthrower to a level surface.
2. Run snowthrower until all fuel has been depleted.
3. Remove ignition key.
4. Place an oil drain pan under the oil drain plug and remove the oil drain plug. Tip the snowthrower backward and drain the used oil in the oil drain pan (Figure 23).

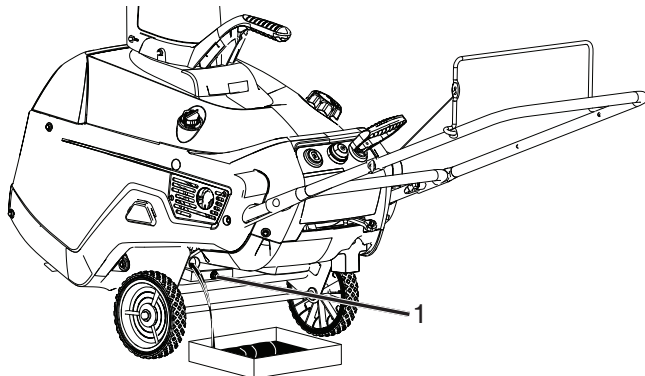

Figure 23

1. Oil drain plug

5. After draining the used oil, return the snowthrower to the operating position.
6. Install the oil drain plug and torque to 145-150 in-lbs (17 N-m).

NOTE: Dipstick location may vary depending on engine type.

7. Clean around the oil filler cap/dipstick (Figure 24).
8. Unscrew and remove the oil fill cap/dipstick.

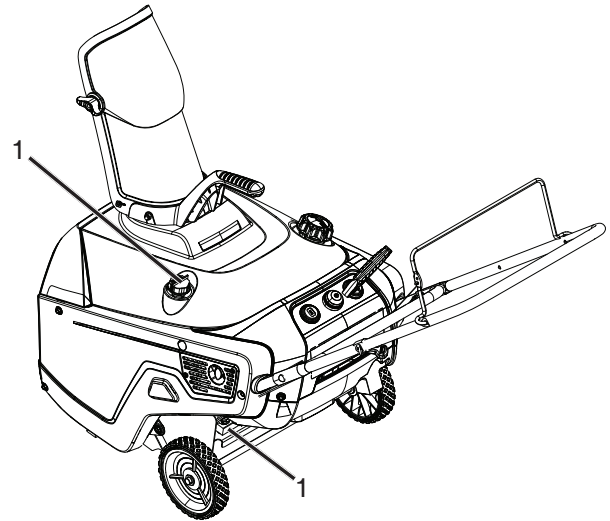

Figure 24

1. Oil fill cap/dipstick

9. With the snowthrower in the operating position, carefully pour oil into the oil fill hole until "Full" on the fill cap/dipstick line (Figure 25).

Max fill: 18 oz. (0.5 l), type: automotive detergent oil with an API service classification of SJ, SL, or higher.

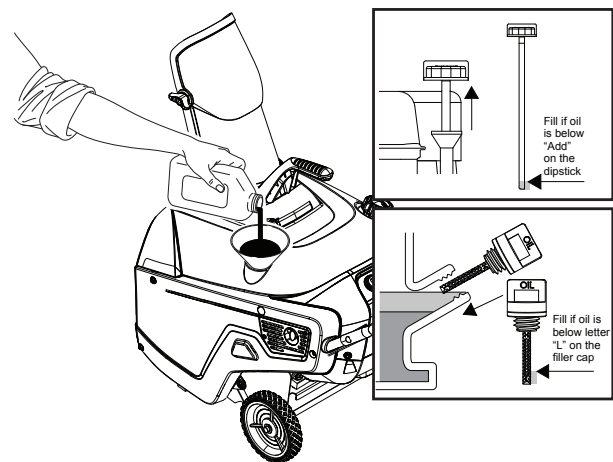

Figure 25

10. Screw in the oil fill cap/dipstick and hand tighten it securely.
11. Wipe up any spilled oil.
12. Dispose of the used oil properly at a local recycling center.

Servicing the Spark Plug

Use a NGK BPR6ES, Champion RN9YC, or BOSCH WR6DC spark plug or equivalent.

1. Stop the engine and wait for all moving parts to stop.
2. Rotate the discharge chute so that it faces forward.
3. Remove the discharge chute and the discharge chute handle by removing the three carriage bolts and three flange nuts (Figure 26).

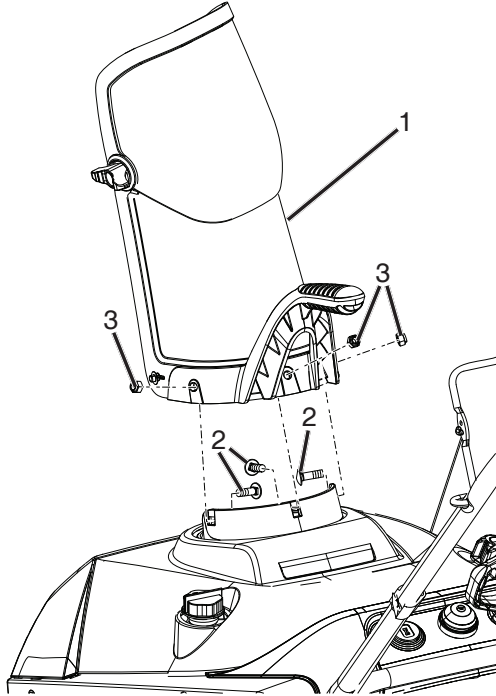

Figure 26

1. Discharge chute
2. Carriage bolts
3. Flange nuts

4. Remove the six screws that secure the shroud assembly (Figure 27).
5. Remove the oil fill cap.
6. Remove the shroud assembly.

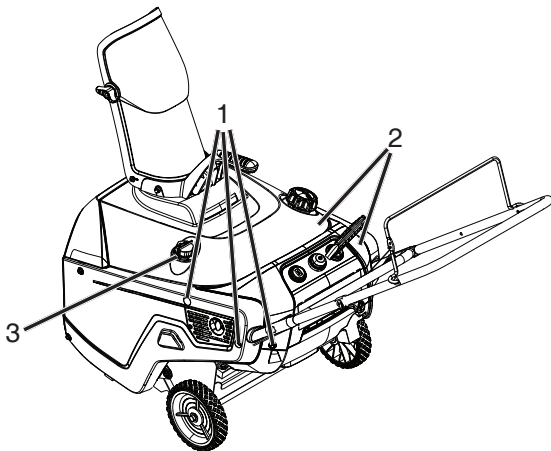

Figure 27

1. Screw
2. Shroud assembly
3. Oil fill cap

7. Install the oil fill cap.
8. Disconnect the spark plug wire from the spark plug (Figure 28).

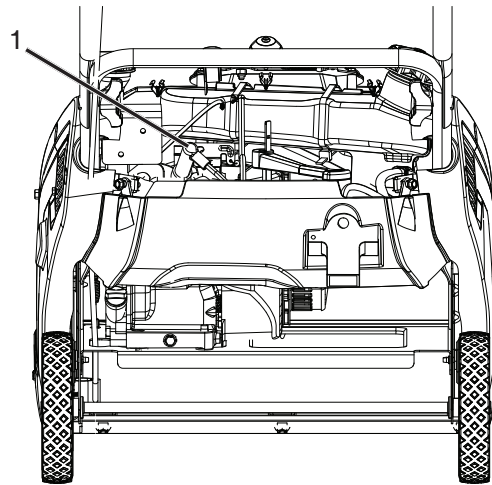

Figure 28

1. Spark plug wire

9. Clean around the spark plug.
10. Remove the spark plug from the cylinder head.

IMPORTANT: Replace a cracked, fouled, or dirty spark plug. Do not clean the electrodes because grit entering the cylinder can damage the engine.

11. Set the gap on the plug to 0.030 inch (0.76 mm) (Figure 29).

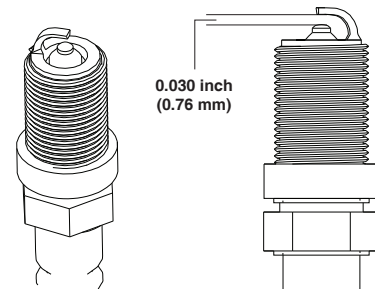

Figure 29

12. Install the spark plug and torque to 20–22 ft-lb (27-30 N-m).
13. Connect the spark plug wire to the spark plug (Figure 28).
14. Remove the oil fill cap.
15. Install the shroud with the screws removed in step 4 (Figure 27).

NOTE: Ensure that the shroud assembly fits together in the side grooves.

16. Install the oil fill cap.
17. Install the discharge chute, and the discharge chute handle onto the snowthrower using the hardware removed in step 3 (Figure 26).

Replacing the Drive Belt

If drive belt becomes worn, oil-soaked, excessively cracked, frayed, or otherwise damaged, replace the belt.

1. Remove the drive side cover by removing the six screws as shown in (Figure 30).

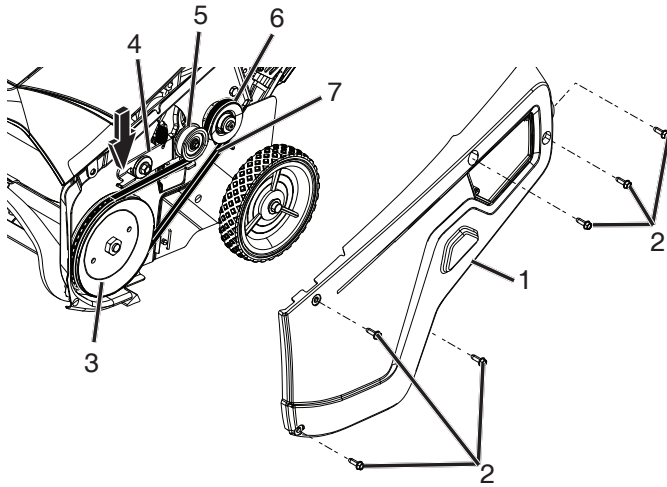

Figure 30

- | | |
|---------------------|------------------|
| 1. Drive side cover | 5. Idler pulley |
| 2. Screw | 6. Engine pulley |
| 3. Drive pulley | 7. Drive belt |
| 4. Idler arm | |

2. Press down on front of idler arm to release the belt tension (Figure 31).
3. Remove the drive belt from the drive pulley (Figure 31).

4. Install the new drive belt, routing it as shown in Figure 31.

NOTE: Route the new drive belt first around the engine pulley, then the idler pulley, and finally around the drive pulley while pressing down on the front of the idler arm. (Figure 31).

5. Install the drive side cover with the screws removed in step 1.

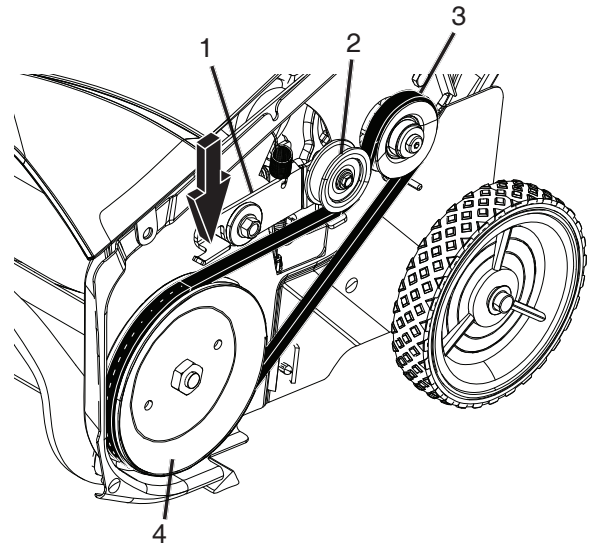

Figure 31

- | |
|------------------|
| 1. Idler arm |
| 2. Idler pulley |
| 3. Engine pulley |
| 4. Drive pulley |

NOTE: Ensure that the drive belt is properly adjusted and operating; refer to Checking the Control Cable and Adjusting the Control Cable in the Maintenance section of this manual.

Storage

STORING THE SNOWTHROWER

Immediately prepare your snow thrower for storage at the end of the season or if the unit will not be used for 30 days or more.



WARNING: Never store the snow thrower with gasoline in the tank inside a building where fumes may reach an open flame, spark or pilot light as on a furnace, water heater, clothes dryer or gas appliance. Allow the engine to cool before storing in any enclosure.

SNOW THROWER

When snow thrower is to be stored for a period of time, clean it thoroughly, remove all dirt, grease, leaves, etc. Store in a clean, dry area.

1. Clean entire snow thrower after each use.
2. Inspect and replace belts, if necessary (See "Replacing the Drive Belt" section of this manual).
3. Be sure that all nuts, bolts, screws, and pins are securely fastened. Inspect moving parts for damage, breakage and wear. Replace if necessary.

FUEL SYSTEM

IMPORTANT: It is important to prevent gum deposits from forming in essential fuel system parts such as carburetor, fuel hose, or tank during storage. Also, alcohol blended fuels can attract moisture which leads to separation and formation of acids during storage. Acidic gas can damage the fuel system of an engine while in storage.

- Empty the fuel tank by starting the engine and letting it run until the fuel lines and carburetor are empty.
- Never use engine or carburetor cleaner products in the fuel tank or permanent damage may occur.
- Use fresh fuel next season.

NOTE: Fuel stabilizer is an acceptable alternative in minimizing the formation of fuel gum deposits during storage. Add stabilizer to gasoline in fuel tank or storage container. Always follow the mix ratio found on stabilizer container. Run engine at least 10 minutes after adding stabilizer to allow the stabilizer to reach the carburetor. Do not empty the gas tank and carburetor if using fuel stabilizer.

ENGINE OIL

Drain oil (with engine warm) and replace with clean engine oil. (See "Changing the Engine Oil" section of this manual).

CYLINDER

1. Remove spark plug.
2. Pour one ounce (29 ml) of oil through spark plug hole into cylinder.
3. Pull recoil starter handle slowly a few times to distribute oil.

OTHER

- Remove safety ignition key; store it in a safe place.
- Do not store gasoline from one season to another.
- Replace your gasoline can if your can starts to rust. Rust and/or dirt in your gasoline will cause problems.
- If possible, store your snow thrower indoors and cover it to protect it from dust and dirt.
- Cover your snow thrower with a suitable protective cover that does not retain moisture. Do not use plastic. Plastic cannot breathe, which allows condensation to form and will cause your snow thrower to rust.

IMPORTANT: Never cover snow thrower while engine/exhaust area is still warm.

Troubleshooting

See appropriate section in manual unless directed to a service center/department.

PROBLEM	CAUSE	CORRECTION
Does not start	<ol style="list-style-type: none"> 1. Safety ignition key is not inserted. 2. Out of fuel. 3. ON/OFF switch is OFF. 4. Choke in OFF position. 5. Primer not depressed. 6. Engine is flooded. 7. Spark plug wire is disconnected. 8. Bad spark plug. 9. Stale fuel. 10. Water in fuel. 11. Vapor locked fuel line. 	<ol style="list-style-type: none"> 1. Insert safety ignition key. 2. Fill fuel tank with fresh, clean gasoline. 3. Move ON/OFF switch to ON position. 4. Move to FULL position. 5. Prime as instructed in the Operation section of this manual. 6. Wait a few minutes before restarting, DO NOT prime. 7. Connect wire to spark plug. 8. Replace spark plug. 9. Empty fuel tank & carburetor, refill with fresh, clean gasoline. 10. Empty fuel tank & carburetor, refill with fresh, clean gasoline. 11. Ensure all the fuel line is below the outlet of the fuel tank. Fuel line should run continuously down from fuel tank to carburetor.
Loss of power	<ol style="list-style-type: none"> 1. Spark plug wire loose. 2. Throwing too much snow. 3. Fuel tank cap is covered with ice or snow. 4. Dirty or clogged muffler. 5. Improper cable length. 6. Blocked muffler. 7. Blocked carburetor air intake. 	<ol style="list-style-type: none"> 1. Reconnect spark plug wire. 2. Reduce speed and width of swath. 3. Remove ice and snow on and around fuel tank cap. 4. Clean or replace muffler. 5. Adjust cable. 6. Clear blockage (ensure engine is cool). 7. Clear blockage (ensure engine is cool).
Engine idles or runs roughly	<ol style="list-style-type: none"> 1. Choke is in FULL position. 2. Blockage in fuel line. 3. Stale fuel. 4. Water in fuel. 5. Carburetor is in need of replacing 6. Belt stretch. 	<ol style="list-style-type: none"> 1. Move choke to OFF position. 2. Clean fuel line. 3. Empty fuel tank & carburetor, refill with fresh, clean gasoline. 4. Empty fuel tank & carburetor, refill with fresh, clean gasoline. 5. Contact an authorized service center/department. 6. Replace auger v-belt.
Excessive vibration / Handle movement	<ol style="list-style-type: none"> 1. Loose parts or damaged augers or impeller. 2. Handles not positioned correctly. 3. Adjustment lever nuts are loose. 	<ol style="list-style-type: none"> 1. Tighten all fasteners. Replace damaged parts. If vibration remains, contact an authorized service center/department. 2. Ensure handles are locked into positioning. 3. Tighten nuts until handle feels secure.
Recoil starter is hard to pull	<ol style="list-style-type: none"> 1. Frozen recoil starter. 2. Rope is interfering with components. 	<ol style="list-style-type: none"> 1. See "IF RECOIL STARTER HAS FROZEN" in the Operation section of this manual. 2. Recoil rope should not be touching any wires or hoses.
Loss of snow discharge or slowing of snow discharge	<ol style="list-style-type: none"> 1. Worn belt. 2. Auger v-belt is off of pulley. 3. Auger v-belt is worn. 4. Clogged discharge chute. 5. Augers / impeller jammed. 	<ol style="list-style-type: none"> 1. Adjust drive cable per maintenance procedures. 2. Check / reinstall auger v-belt. 3. Check / replace auger v-belt. 4. Clean snow chute. 5. Remove debris or foreign object from augers / impeller.
Lights not On (If Equipped)	<ol style="list-style-type: none"> 1. Motor not running. 2. Loose wire connection. 3. LED burnt out. 	<ol style="list-style-type: none"> 1. Start engine. 2. Check wire connections at engine and both lights. 3. Replace LED light module. (Individual LEDs are not replaceable)
Rotator hard to move	<ol style="list-style-type: none"> 1. Debris in chute rotator mechanism. 2. Cable are kinked or damaged. 	<ol style="list-style-type: none"> 1. Clean internal parts of chute rotator mechanism. 2. Ensure cables are not kinked. Replace damaged cables.

REPAIR PARTS SNOW THROWER - - MODEL NUMBER PR121ES (96182001701)

AUGER ASSEMBLY

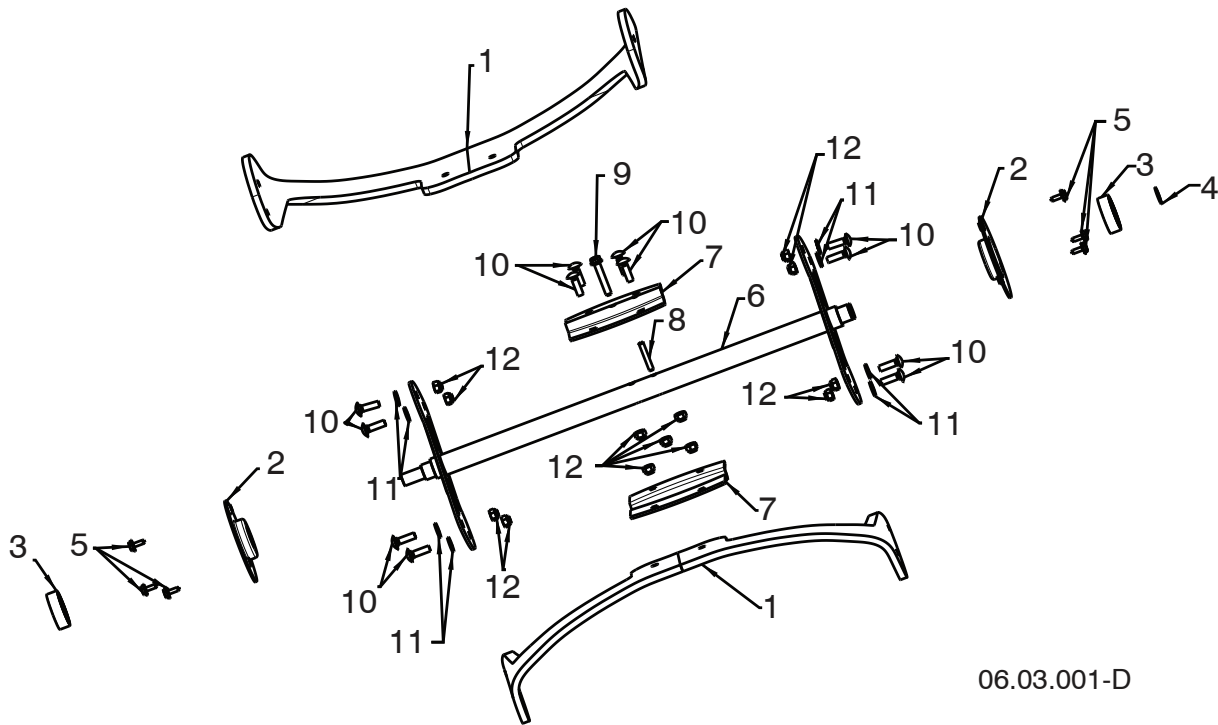

06.03.001-D

KEY NO.	PART NO.	DESCRIPTION
1	532 44 27-59	BLADE
2	580 85 55-01	BEARING SUPPORT
3	532 43 76-22	BALL BEARING
4	812 00 00-28	RETAINING RING
5	817 06 04-08	1/4-20 X 3/8 HEX SCREW
6	532 43 76-17	AUGER WELDMENT
7	580 85 54-01	CENTER BLADE PLATE
8	532 43 76-20	ROLL PIN
9	532 19 96-87	SCREW HEX WS HD 1/4-20 X 1.5
10	872 11 04-07	BOLT CARRIAGE 1/4-20 X 7/8
11	819 09 10-16	WASHER FLAT 1/4 SAE
12	532 13 20-04	NUT HEX 1/4-20 BZO

NOTE: All component dimensions given in U.S. inches. 1 inch = 25.4 mm
IMPORTANT: Use only Original Equipment Manufacturer (O.E.M.) replacement parts. Failure to do so could be hazardous, damage your snow thrower and void your warranty.

REPAIR PARTS SNOW THROWER - - MODEL NUMBER PR121ES (96182001701)

CHUTE ASSEMBLY

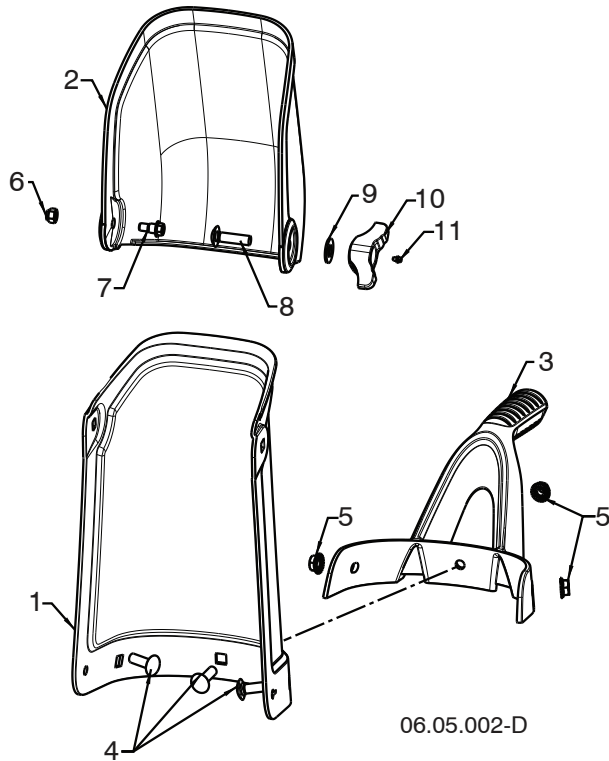

KEY NO.	PART NO.	DESCRIPTION
1	532 43 76-41	CHUTE (BLACK)
2	532 43 76-43	DEFLECTOR (BLACK)
3	532 43 76-42	HANDLE (BLACK)
4	532 43 73-18	CARRIAGE BOLT 5/16-18 UNC X 1
5	873 97 05-00	NUT LOCK HEX W/INS 5/16-18 UNC PL
6	532 13 20-04	NUT HEX 1/4 – 20 NYLON LOCKING
7	532 44 46-82	SHOULDER BOLT ¼-20 HEX HEAD
8	872 11 05-10	CARRIAGE BOLT 5/16-18 X 1-1/4
9	819 13 13-16	WASHER 13/32 X 13/16 X 16 GA
10	532 19 19-38	WING KNOB
11	532 07 16-73	CAP PLUNGER

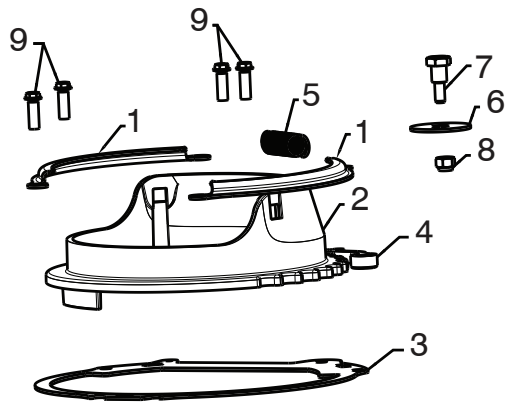

KEY NO.	PART NO.	DESCRIPTION
1	580 85 65-01	CHUTE RETAINER
2	587 23 81-01	CHUTE BASE
3	580 85 56-01	CHUTE BASE PLATE
4	532 43 48-78	RATCHET PAWL
5	532 43 48-79	SPRING
6	819 13 24-16	WASHER 13/32 X 1.25
7	532 08 13-28	BOLT 1/4-20 X .94
8	532 13 20-04	NUT 1/4-20 HEX
9	817 41 13-12	BOLT 13-16 X .75

06.04.009-C

NOTE: All component dimensions given in U.S. inches. 1 inch = 25.4 mm
IMPORTANT: Use only Original Equipment Manufacturer (O.E.M.) replacement parts. Failure to do so could be hazardous, damage your snow thrower and void your warranty.

REPAIR PARTS SNOW THROWER - - MODEL NUMBER PR121ES (96182001701) HANDLE ASSEMBLY

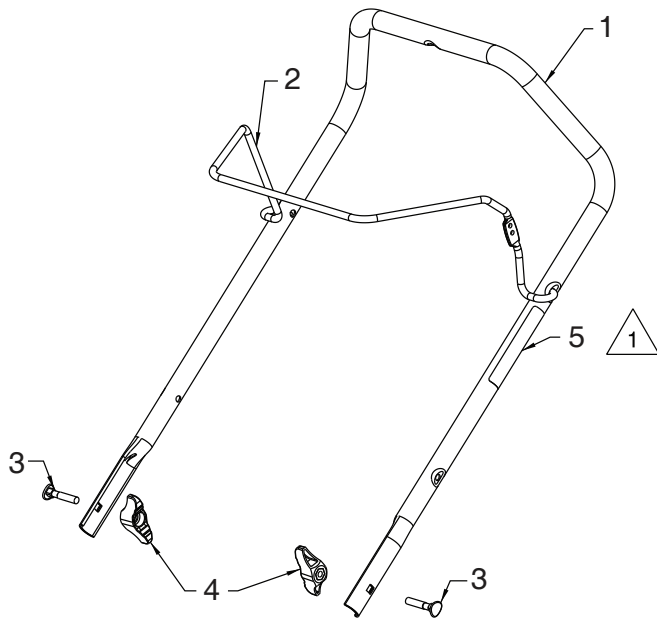

KEY NO.	PART NO.	DESCRIPTION
1	580 85 68-01	HANDLE ERGO SSST SHORT
2	580 86 05-01	BAIL ERGO SSST
3	532 19 15-74	BOLT HANDLE
4	532 19 19-38	KNOB WING
5	532 43 75-06	DECAL AUGER

06.07.002-C

NOTE: All component dimensions given in U.S. inches. 1 inch = 25.4 mm
IMPORTANT: Use only Original Equipment Manufacturer (O.E.M.) replacement parts.
 Failure to do so could be hazardous, damage your snow thrower and void your warranty.

REPAIR PARTS SNOW THROWER - - MODEL NUMBER PR121ES (96182001701) DRIVE ASSEMBLY

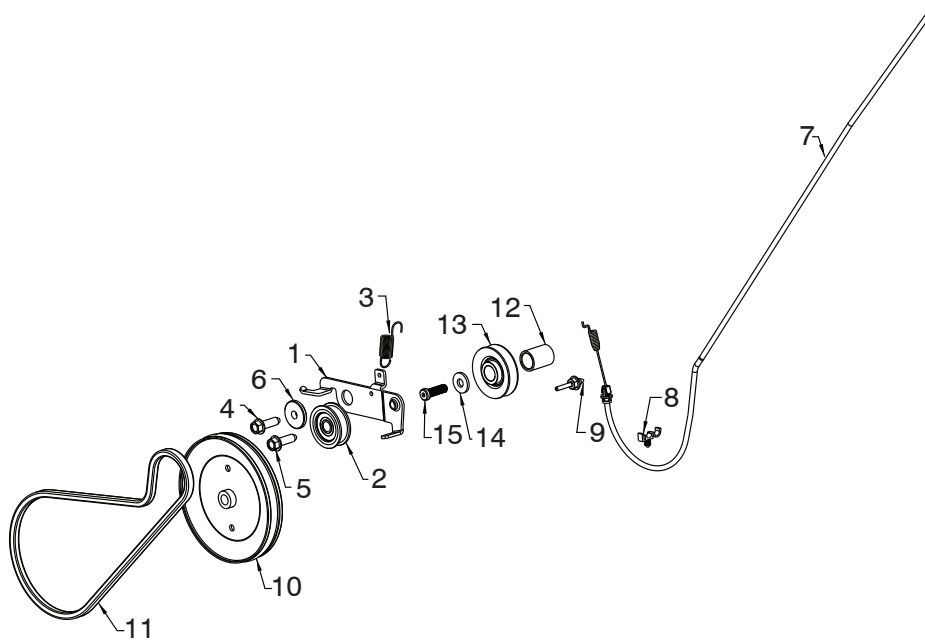

06.01.001-A

KEY NO.	PART NO.	DESCRIPTION
1	580 85 53-01	IDLER ARM
2	532 16 60-43	IDLER PULLEY
3	532 43 48-59	RETURN SPRING
4	817 06 06-20	SCREW 3/8-16 X 1-1/4 (TORQUE 13-18 FT-LBS)
5	817 06 06-20	SCREW 3/8-16 X 1-1/4 (TORQUE 22-27 FT-LBS)
6	532 19 90-92	SPACER
7	532 44 30-18	CLUTCH CABLE ASM
8	532 14 50-06	PUSH CLIP
9	532 43 45-02	BELT KEEPER
10	532 43 53-83	DRIVE PULLEY
11	532 43 72-61	BELT
12	532 43 48-60	ENGINE CRANK SPACER
13	532 42 64-90	ENGINE PULLEY
14	532 85 10-74	WASHER
15	532 43 08-17	SCREW 3/8-24 X 1/25

NOTE: All component dimensions given in U.S. inches. 1 inch = 25.4 mm
IMPORTANT: Use only Original Equipment Manufacturer (O.E.M.) replacement parts.
 Failure to do so could be hazardous, damage your snow thrower and void your warranty.

REPAIR PARTS SNOW THROWER - - MODEL NUMBER PR121ES (96182001701) ENGINE ASSEMBLY

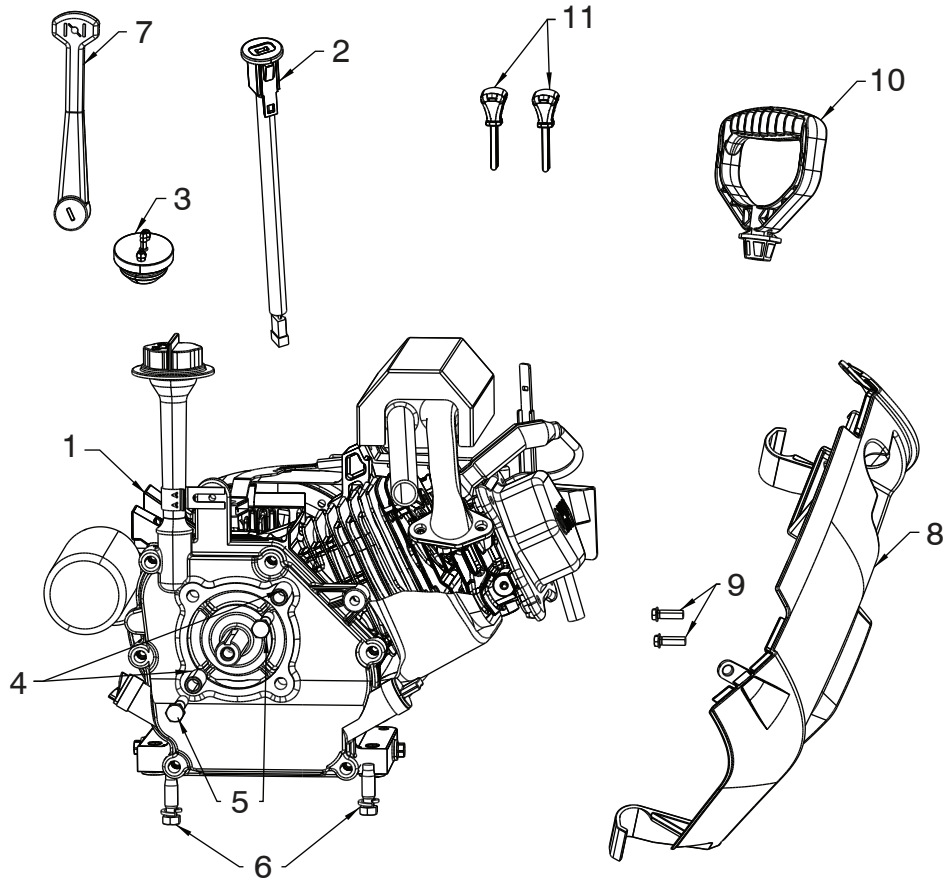

06.02.010-A

KEY NO.	PART NO.	DESCRIPTION
1	580 81 08-01	ENGINE LCT 208CC US PW3HK1865018E
2	580 85 02-01	KEY SWITCH
3	532 43 62-35	PRIMER BULB
4	532 43 48-57	SPACER ENGINE
5	532 43 55-78	SCREW 5/16-24 X 2.00 HHCS
6	532 15 04-06	BOLT ENGINE 3/8-16 DOGPOINT
7	532 43 48-74	LEVER CHOKE
8	532 43 76-58	COVER REAR LOWER
9	817 41 13-12	SCREW HEX WSHHD #13 X .750
10	532 42 49-68	RECOIL HANDLE
11	532 44 30-59	KEY SET (QTY: 2)

NOTE: All component dimensions given in U.S. inches. 1 inch = 25.4 mm
IMPORTANT: Use only Original Equipment Manufacturer (O.E.M.) replacement parts.
 Failure to do so could be hazardous, damage your snow thrower and void your warranty.

REPAIR PARTS SNOW THROWER - - MODEL NUMBER PR121ES (96182001701)

FRAME ASSEMBLY

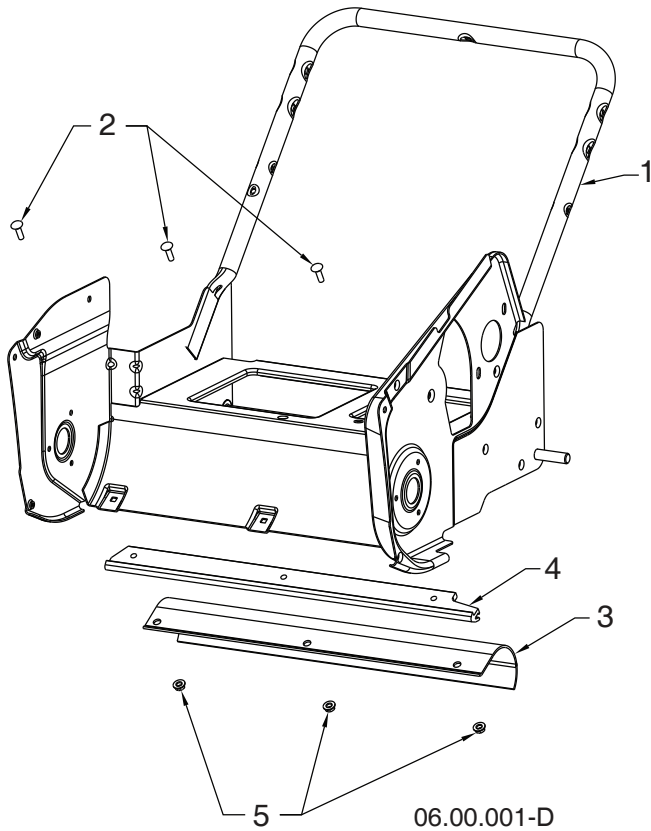

KEY NO.	PART NO.	DESCRIPTION
1	580 85 62-01	FRAME WELDMENT
2	872 11 04-07	BOLT CARRIAGE 1/4-20 X 7/8
3	532 44 21-46	SCRAPER SKIRT
4	580 50 26-01	BAR SCRAPER UHMW
5	532 19 17-30	NUT HEX FLANGE 1/4-20 CTR LOCK

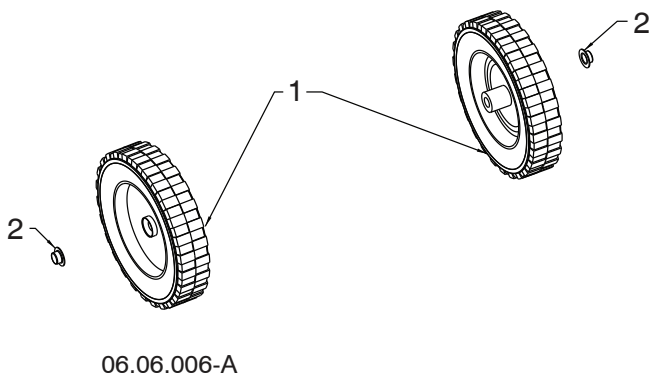

KEY NO.	PART NO.	DESCRIPTION
1	532 43 76-62	WHEEL 8"
2	532 43 54-17	PUSH NUT

NOTE: All component dimensions given in U.S. inches. 1 inch = 25.4 mm
IMPORTANT: Use only Original Equipment Manufacturer (O.E.M.) replacement parts.
 Failure to do so could be hazardous, damage your snow thrower and void your warranty.

REPAIR PARTS SNOW THROWER - - MODEL NUMBER PR121ES (96182001701)

SHROUD ASSEMBLY

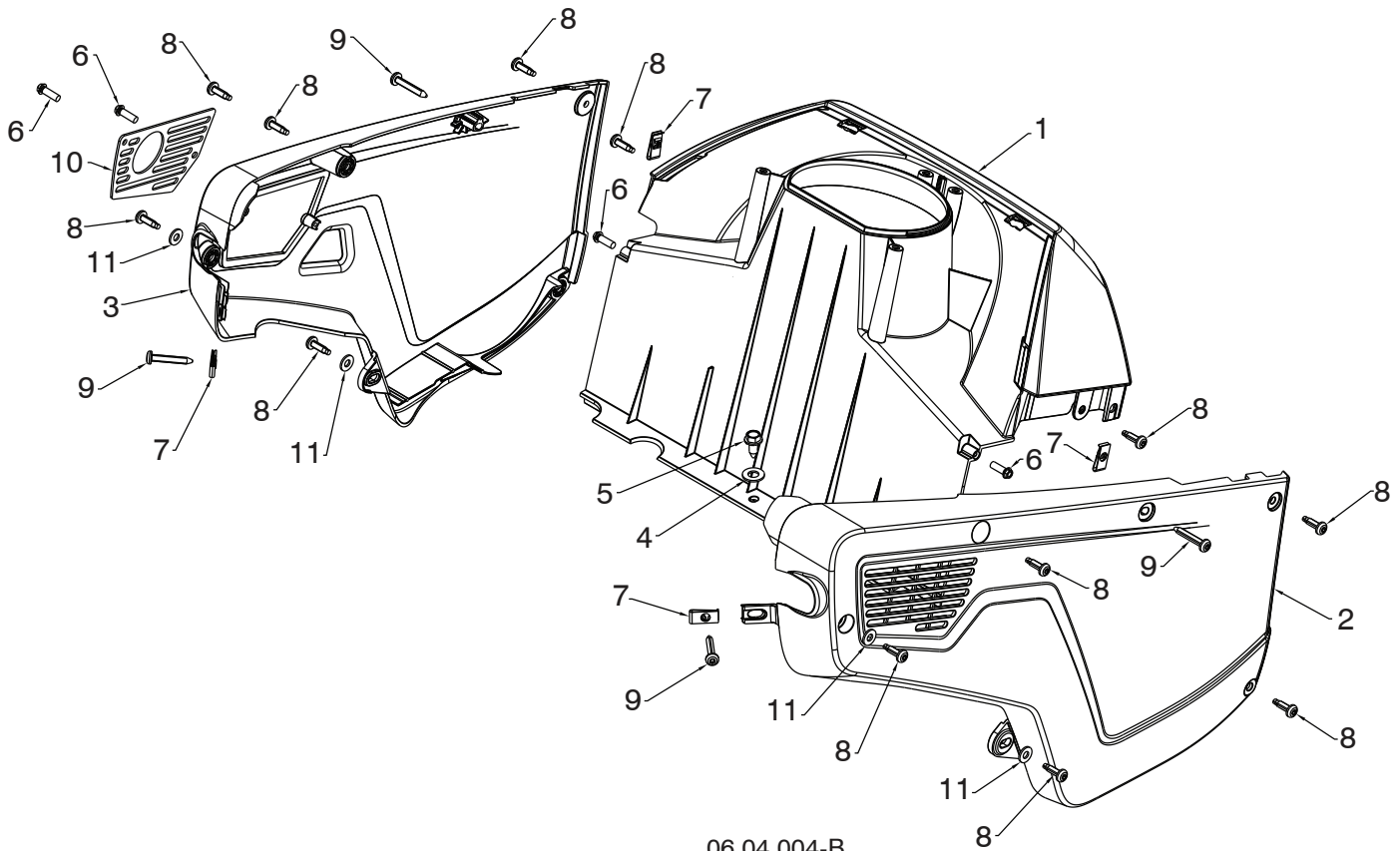

KEY NO.	PART NO.	DESCRIPTION
1	584 99 03-03	PLENUM
2	584 98 99-06	NON-DRIVE COVER
3	584 99 00-06	DRIVE COVER SIDE
4	819 13 13-16	WASHER 13/32 X 13 X 16 16 GA.
5	532 42 88-67	BOLT 5/16-18 X .75
6	817 41 13-12	BOLT 13-16 X .75
7	532 19 66-88	THREADED CLIP
8	532 44 22-50	SCREW 1/4-20 X .75
9	532 44 42-62	SCREW 1/4-20 X 1.5
10	532 43 48-73	EXHAUST PLATE
11	819 09 10-16	WASHER FLAT 1/4 SAE

NOTE: All component dimensions given in U.S. inches. 1 inch = 25.4 mm
IMPORTANT: Use only Original Equipment Manufacturer (O.E.M.) replacement parts. Failure to do so could be hazardous, damage your snow thrower and void your warranty.

REPAIR PARTS SNOW THROWER - - MODEL NUMBER PR121ES (96182001701) SHROUD ASSEMBLY

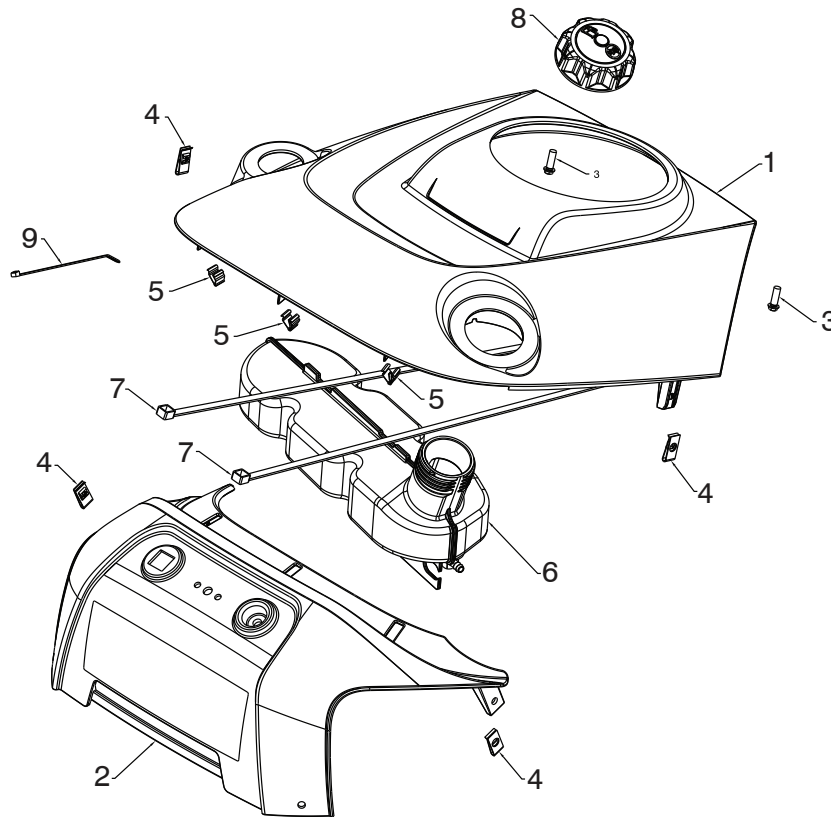

06.04.011-F

KEY NO.	PART NO.	DESCRIPTION
1	532 44 33-99	TOP COVER
2	588 75 39-01	REAR UPPER COVER
3	817 41 13-12	BOLT 13-16 X .75
4	532 19 66-88	THREADED CLIP
5	532 43 48-68	TRIM CLIP
6	580 98 26-01	FUEL TANK ASSEMBLY
7	532 14 68-48	CABLE TIE
8	581 07 55-01	FUEL CAP/GASKET
9	532 00 71-92	CABLE TIE

NOTE: All component dimensions given in U.S. inches. 1 inch = 25.4 mm
IMPORTANT: Use only Original Equipment Manufacturer (O.E.M.) replacement parts.
 Failure to do so could be hazardous, damage your snow thrower and void your warranty.

REPAIR PARTS SNOW THROWER - - MODEL NUMBER PR121ES (96182001701) ENGINE, LCT COMPLETE ENGINE - 580810801

136/179/208cc Single-Stage Snow Engines

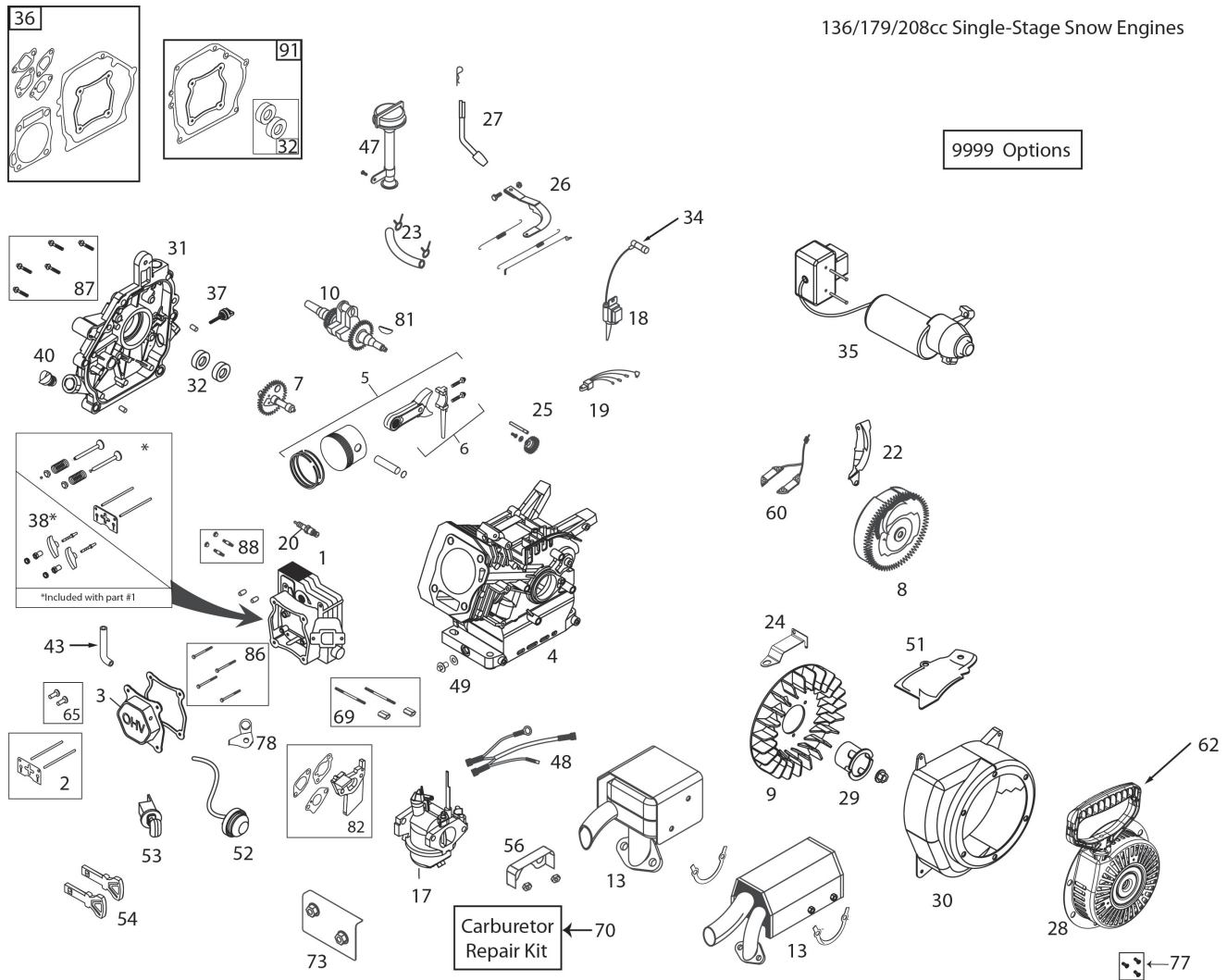

ILLUSTRATION FOR REFERENCE PURPOSES ONLY

KEY PART NO.	NO.	DESCRIPTION	KEY PART NO.	NO.	DESCRIPTION
1	532 42 05-78	CYLINDER HEAD ASSEMBLY - 208CC (INCL. GASKET)	6	532 42 05-83	CONNECTING ROD ASSEMBLY (208CC)
2	532 42 05-79	PUSH ROD & PLATE KIT (208CC)(INCL. VALVE COVER GSKT)	7	532 42 05-84	CAMSHAFT - MCR (208CC)
3	532 42 05-80	VALVE COVER (208CC) (INCL. GASKET)-OBSOLETE (SK2084501.1)	8	532 42 92-35	FLYWHEEL - ELECTRIC START (2-CHARGING MAGNETS) (208CC)
4	532 43 65-67	CYLINDER - 208CC GEN LL SNOW	9	532 42 05-86	COOLLNG FAN - FLYWHEEL (PLASTIC - 208CC)
5	532 42 05-82	PISTON & ROD ASSEMBLY (208CC)	10	532 44 66-42	CRANKSHAFT (#18 KEYED 208CC SNOW)
			13	532 44 42-77	MUFFLER ASSY (208CC SS SNOW) (PPP)

NOTE: All component dimensions given in U.S. inches. 1 inch = 25.4 mm
IMPORTANT: Use only Original Equipment Manufacturer (O.E.M.) replacement parts. Failure to do so could be hazardous, damage your snow thrower and void your warranty.

**REPAIR PARTS SNOW THROWER - - MODEL NUMBER PR121ES (96182001701)
ENGINE, LCT**

COMPLETE ENGINE - 580810801

KEY PART NO.	PART NO.	DESCRIPTION	KEY PART NO.	PART NO.	DESCRIPTION
17	532 43 71-22	CARBURETOR (L10-4) (SS SNOW 208CC- W/GSKTS & SPACER)	47	532 44 40-91	HIGH OIL-FILL TUBE/DIPSTICK (ROUND THREADED TYPE) (SN <1265H
18	532 44 39-34	IGNITION COIL (CDI) (208CC) (STANDARD)	48	532 44 42-76	WIRE HARNESS (SINGLE STAGE)-SNOW
19	N/A	N/A	49	532 43 54-95	OIL DRAIN PLUG W/WASHER (136/208/254CC)
20	532 42 49-39	SPARK PLUG	51	532 43 71-19	SHIELD - CYLLNDER
22	532 42 49-75	SHIELD - FLYWHEEL - ELECTRIC START - SNOW	52	532 43 71-23	PRIMER BULB W/HOSE KIT (SINGLE STAGE)SNOW
23	532 43 80-14	FUEL HOSE KIT - SINGLE STAGE SNOW (318MM)	53	532 42 49-54	SAFETY KEY SWITCH -SNOW (INCL. KEYS)
24	532 42 92-59	SPEED CONTROL BRACKET (FIXED)	54	532 44 30-59	KEY SET - RED (2) (SNOW)
25	532 42 96-46	GOVERNOR GEAR ASSEMBLY (136/208CC)	56	532 42 92-60	CARBURETOR VAPOR SHIELD - 208CC SNOW
26	581 76 87-01	GOVERNOR ARM & LINK KIT (208CC SNOW - 3600 FIXED RPM)	60	N/A	N/A
27	532 42 06-02	GOVERNOR ARM PADDLE	62	532 42 49-68	STARTER GRIP-SNOW
28	585 77 12-01	RECOIL STARTER (SINGLE-STAGE 78" ROPE)	65	581 37 28-01	TAPPET KIT (208/254CC) (SET OF 2)
29	532 43 69-68	STARTER CUP (USE WITH ROUND STYLE STARTER) (208CC SNOW)	69	532 42 49-51	CARBURETOR STUDS & COU- PLLNG KIT-SNOW
30	580 96 05-01	BLOWER HOUSING - BLACK ELECTRIC START W/WELDNUT (208CC)	70	580 35 36-01	CARBURETOR REPAIR KIT (136/208/254CC)
31	532 42 06-06	CRANKCASE COVER ASSY-HOFT (THREADED) (INCL. GASKET)	73	532 44 42-75	INTAKE SHIELD (208CC SS SNOW)
32	532 42 95-99	OIL SEAL KIT (2 PCS FOR 3/4-INCH CRANKSHAFT)	77	532 43 26-88	RECOIL BOLT KIT (3 BOLTS PER KIT)
34	532 43 69-66	SPARK PLUG BOOT - WITH METAL SHIELD (SNOW)	78	581 45 93-01	BREATHER TUBE BRACKET
35	532 43 71-24	120V ELECTRIC STARTER (208CC SS SNOW)	81	585 29 72-01	WOODRUFF FLYWHEEL KEYS (5-PACK) (5X6X18MM) (208/414CC)
36	532 42 96-01	ENGINE GASKET KIT (208CC)	82	585 02 05-03	208CC/254CC CARBURETOR SPACER KIT
37	532 42 09-61	SMALL BLACK OIL DIPSTICK (PLASTIC)	86	586 32 73-01	CYLINDER HEAD BOLT KIT (4) (136-179-208-254CC)
38	532 42 96-91	ROCKER ARM KIT (208CC) (INCL. GASKET)	87	586 32 69-01	CC COVER BOLT KIT (6) (179-208-254CC)
40	532 42 95-98	NON-REMOVABLE PLASTIC PLUG (136/208/254CC)	88	586 32 68-01	MUFFLER MTG STUD KIT (2)
43	580 35 34-01	BREATHER TUBE (136/208/254CC)	91	587 52 57-01	CRANKSHAFT GASKET KIT 179-208CC
			9999	586 32 62-01	HIGH ALTITUDE JET (>6,000 FEET)(208CC L10-1 CARBURETOR)

NOTE: All component dimensions given in U.S. inches. 1 inch = 25.4 mm
IMPORTANT: Use only Original Equipment Manufacturer (O.E.M.) replacement parts.
 Failure to do so could be hazardous, damage your snow thrower and void your warranty.

Poulan PRO