



# INSTALLATION INSTRUCTIONS

## Commercial Dryer Gas or Electric

---

# INSTRUCTIONS D'INSTALLATION

## Sécheuse à usage commercial à gaz ou électrique

---

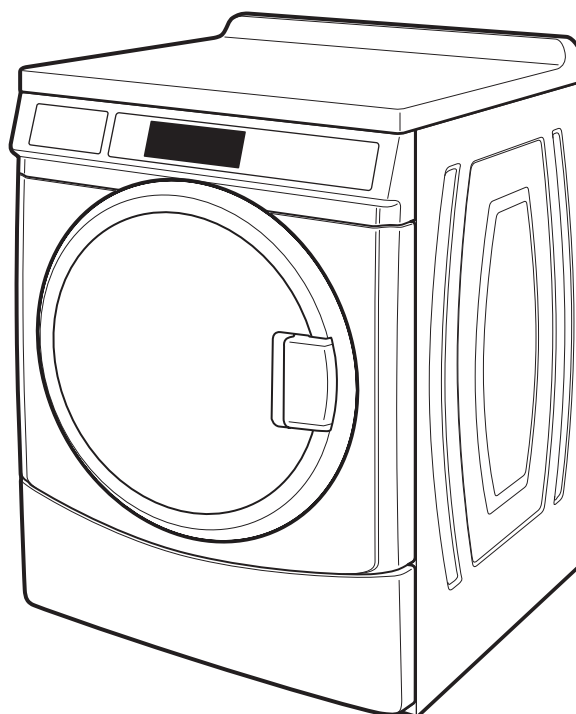
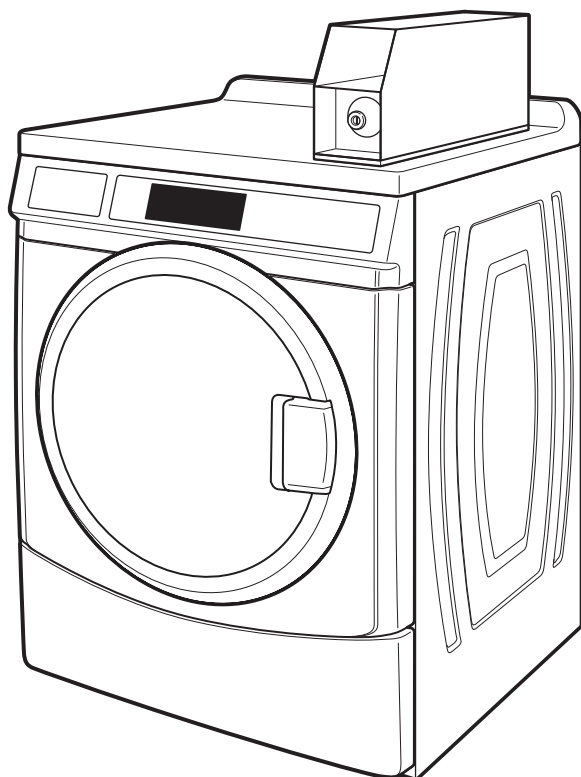

## TABLE OF CONTENTS

	Page
<b>DRYER SAFETY</b> .....	2
<b>INSTALLATION REQUIREMENTS</b> .....	5
Tools and Parts .....	5
Dimensions/Clearances .....	6
Venting Requirements .....	7
Gas Dryer Installation Requirements .....	10
Electric Dryer Installation Requirements .....	14
<b>INSTALLING LEVELING LEGS, COIN SLIDE, AND COIN BOX</b> .....	17
<b>INSTALLATION INSTRUCTIONS – GAS DRYER</b> .....	18
Make Gas Connection .....	18
<b>INSTALLATION INSTRUCTIONS – ELECTRIC DRYER</b> .....	19
Electric Dryer Electrical Connections .....	19
<b>LEVELING</b> .....	24
<b>COMPLETE INSTALLATION</b> .....	24
<b>REVERSING DRYER DOOR SWING</b> .....	25
<b>MAINTENANCE INSTRUCTIONS</b> .....	27
<b>IF YOU NEED ASSISTANCE</b> .....	27
<b>ELECTRONIC CONTROL SETUP INSTRUCTIONS</b> .....	28
<b>WARRANTY</b> .....	34

## TABLE DES MATIÈRES

	Page
<b>SÉCURITÉ DE LA SÈCHEUSE</b> .....	35
<b>EXIGENCES D'INSTALLATION</b> .....	38
Outils et pièces .....	38
Dimensions/Distances de dégagement .....	39
Exigences concernant l'évacuation .....	40
Exigences d'installation pour la sècheuse à gaz.....	43
Exigences d'installation pour la sècheuse électrique .....	47
<b>INSTALLATION DES PIEDS DE NIVELLEMENT, DE LA GLISSIÈRE À MONNAIE ET DE LA CAISSE À MONNAIE</b> .....	49
<b>INSTRUCTIONS D'INSTALLATION POUR LA SÈCHEUSE À GAZ</b> .....	50
Raccordement à la canalisation de gaz .....	50
<b>NIVELLEMENT</b> .....	51
<b>ACHEVER L'INSTALLATION</b> .....	52
<b>INVERSION DU SENS D'OUVERTURE DE LA PORTE DE LA SÈCHEUSE</b> .....	53
<b>INSTRUCTIONS D'ENTRETIEN</b> .....	55
<b>SI VOUS AVEZ BESOIN D'ASSISTANCE</b> .....	55
<b>INSTRUCTIONS DE RÉGLAGE DU TABLEAU DE COMMANDE ÉLECTRONIQUE</b> .....	56
<b>GARANTIE</b> .....	63

## DRYER SAFETY

### Your safety and the safety of others are very important.

We have provided many important safety messages in this manual and on your appliance. Always read and obey all safety messages.



This is the safety alert symbol.

This symbol alerts you to potential hazards that can kill or hurt you and others.

All safety messages will follow the safety alert symbol and either the word "DANGER" or "WARNING."

These words mean:

**⚠ DANGER**

You can be killed or seriously injured if you don't immediately follow instructions.

**⚠ WARNING**

You can be killed or seriously injured if you don't follow instructions.

All safety messages will tell you what the potential hazard is, tell you how to reduce the chance of injury, and tell you what can happen if the instructions are not followed.

- It is recommended that the owner post, in a prominent location, instructions for the customer's use in the event the customer smells gas. This information should be obtained from your gas supplier.
- Post the following warning in a prominent location.

### FOR YOUR SAFETY

Do not store or use gasoline or other flammable vapors and liquids in the vicinity of this or any other appliance.

**⚠ WARNING:**

**FIRE OR EXPLOSION HAZARD**

Failure to follow safety warnings exactly could result in serious injury, death, or property damage.

- Do not store or use gasoline or other flammable vapors and liquids in the vicinity of this or any other appliance.
- **WHAT TO DO IF YOU SMELL GAS:**
  - Do not try to light any appliance.
  - Do not touch any electrical switch; do not use any phone in your building.
  - Clear the room, building, or area of all occupants.
  - Immediately call your gas supplier from a neighbor's phone. Follow the gas supplier's instructions.
  - If you cannot reach your gas supplier, call the fire department.
- Installation and service must be performed by a qualified installer, service agency, or the gas supplier.

**WARNING:** Gas leaks cannot always be detected by smell.

Gas suppliers recommend that you use a gas detector approved by UL or CSA.

For more information, contact your gas supplier.

If a gas leak is detected, follow the "What to do if you smell gas" instructions.

State of California Proposition 65 Warnings:

WARNING: This product contains one or more chemicals known to the State of California to cause cancer.

WARNING: This product contains one or more chemicals known to the State of California to cause birth defects or other reproductive harm.



## **WARNING - "Risk of Fire"**

- Clothes dryer installation must be performed by a qualified installer.
- Install the clothes dryer according to the manufacturer's instructions and local codes.
- Do not install a clothes dryer with flexible plastic venting materials or flexible metal (foil type) duct. If flexible metal duct is installed, it must be of a specific type identified by the appliance manufacturer as suitable for use with clothes dryers. Flexible venting materials are known to collapse, be easily crushed, and trap lint. These conditions will obstruct clothes dryer airflow and increase the risk of fire.
- To reduce the risk of severe injury or death, follow all installation instructions.
- Save these instructions.

# DRYER SAFETY

In the State of Massachusetts, the following installation instructions apply:

- Installations and repairs must be performed by a qualified or licensed contractor, plumber, or gasfitter qualified or licensed by the State of Massachusetts.
- If using a ball valve, it shall be a T-handle type.
- A flexible gas connector, when used, must not exceed 3 feet.

## IMPORTANT SAFETY INSTRUCTIONS

**WARNING:** To reduce the risk of fire, electric shock, or injury to persons when using the dryer, follow basic precautions, including the following:

- Read all instructions before using the dryer.
- Do not place items exposed to cooking oils in your dryer. Items contaminated with cooking oils may contribute to a chemical reaction that could cause a load to catch fire.
- Do not dry articles that have been previously cleaned in, washed in, soaked in, or spotted with gasoline, dry-cleaning solvents, or other flammable or explosive substances as they give off vapors that could ignite or explode.
- Do not allow children to play on or in the dryer. Close supervision of children is necessary when the dryer is used near children.
- Before the dryer is removed from service or discarded, remove the door to the drying compartment.
- Do not reach into the dryer if the drum is moving.
- Do not install or store the dryer where it will be exposed to the weather.
- Do not tamper with controls.
- Do not repair or replace any part of the dryer or attempt any servicing unless specifically recommended in this Use and Care Guide or in published user-repair instructions that you understand and have the skills to carry out.
- Do not use fabric softeners or products to eliminate static unless recommended by the manufacturer of the fabric softener or product.
- Do not use heat to dry articles containing foam rubber or similarly textured rubber-like materials.
- Clean lint screen before or after each load.
- Keep area around the exhaust opening and adjacent surrounding areas free from the accumulation of lint, dust, and dirt.
- The interior of the dryer and exhaust vent should be cleaned periodically by qualified service personnel.
- See “Electrical Requirements” located in the installation instructions for grounding instructions.

**SAVE THESE INSTRUCTIONS**

**IMPORTANT:** The gas installation must conform with local codes, or in the absence of local codes, with the National Fuel Gas Code, ANSI Z223.1/NFPA 54, or the Natural Gas and Propane Installation Code, CSA B149.1.

The dryer must be electrically grounded in accordance with local codes, or in the absence of local codes, with the National Electrical Code, ANSI/NFPA 70, or the Canadian Electrical Code, Part 1, CSA C22.1.



## WARNING

### Fire Hazard

**Failure to follow safety warnings exactly could result in serious injury, death, or property damage.**

**Do not install a booster fan in the exhaust duct.**

**Install all clothes dryers in accordance with the installation instructions of the manufacturer of the dryer.**

## IMPORTANT SAFETY INSTRUCTIONS

When discarding or storing your old clothes dryer, remove the door.

**SAVE THESE INSTRUCTIONS**

# INSTALLATION REQUIREMENTS

## Tools and Parts

### Tools Needed:



8" (200 mm)  
or 10" (250 mm)  
Pipe Wrench



8" (200 mm) or 10" (250 mm)  
Adjustable Wrench  
that opens to 1" (25 mm)

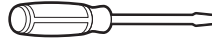

Flat-Blade Screwdriver

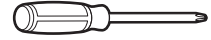

Phillips Screwdriver



TORX® T-20<sup>†</sup> Security  
Screwdriver or Bit



1" (25 mm) Hex-Head  
Socket Wrench



1/4" Socket Wrench

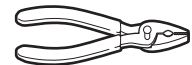

Pliers (that open to  
1<sup>9</sup>/<sub>16</sub>" [39 mm])



Level



Utility Knife



1/4" (6 mm) Nut Driver

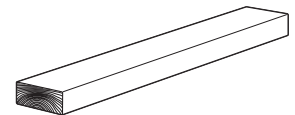

27" (686 mm)  
Wood Block

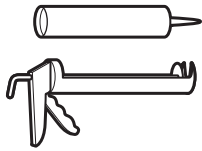

Caulk Gun and Caulk  
(for installing new exhaust vent)



Vent Clamps



Pipe-Joint Compound  
suitable for gas type

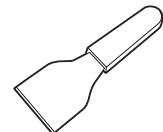

Putty Knife

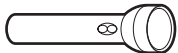

Flashlight (optional)



1" (25 mm)  
Open-End Wrenches

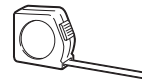

Ruler or Measuring Tape

### Parts Supplied:



Foot Boots (4)

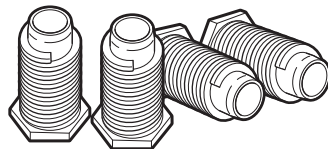

Leveling Legs (4)

To locate factory specified replacement parts in your area, contact the dealer from whom you purchased your dryer.

<sup>†</sup>TORX and T20 are registered trademarks of Acument Intellectual Properties, LLC.

# INSTALLATION REQUIREMENTS

## Dimensions/Clearances

### Dimensions

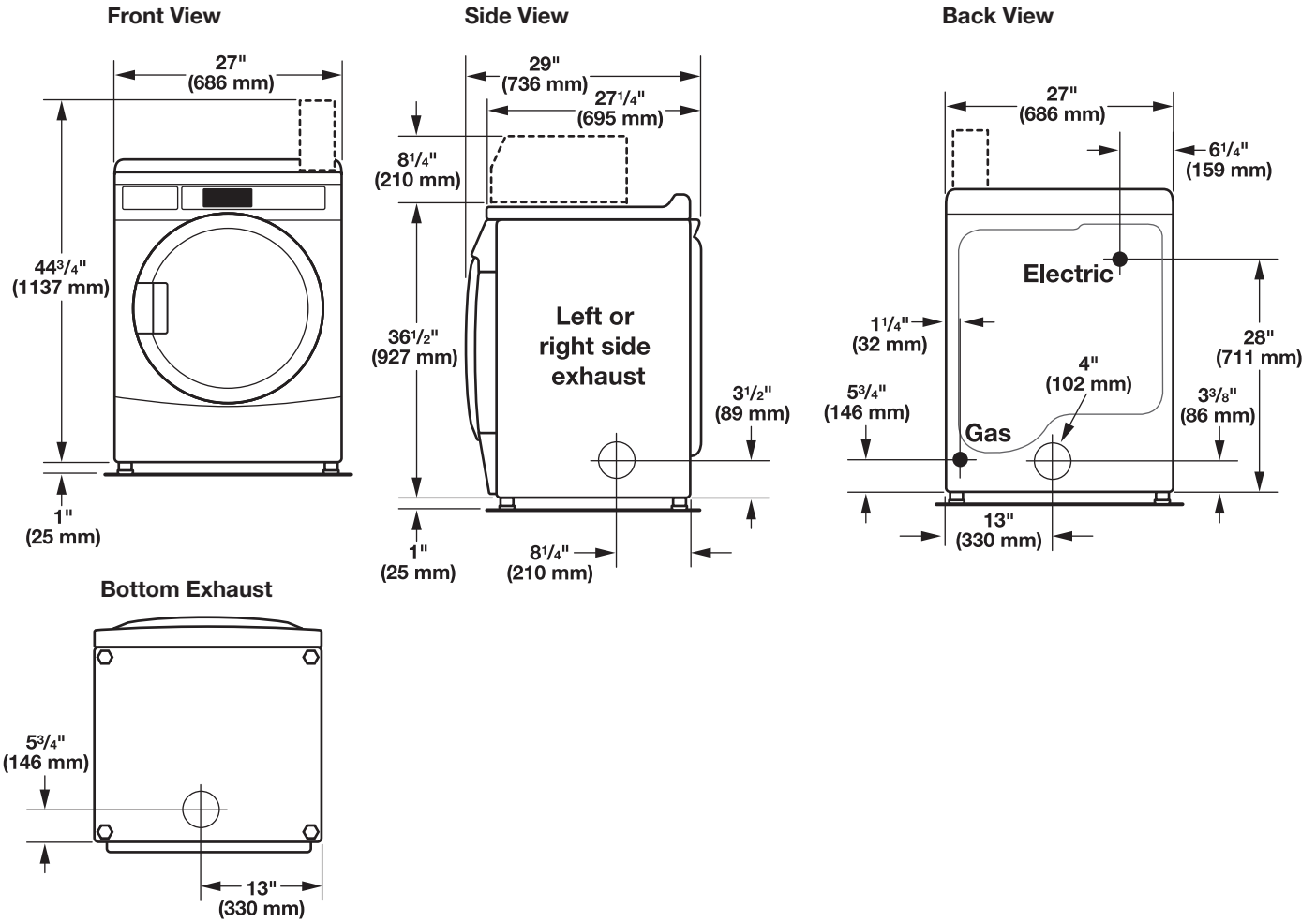

### Clearances

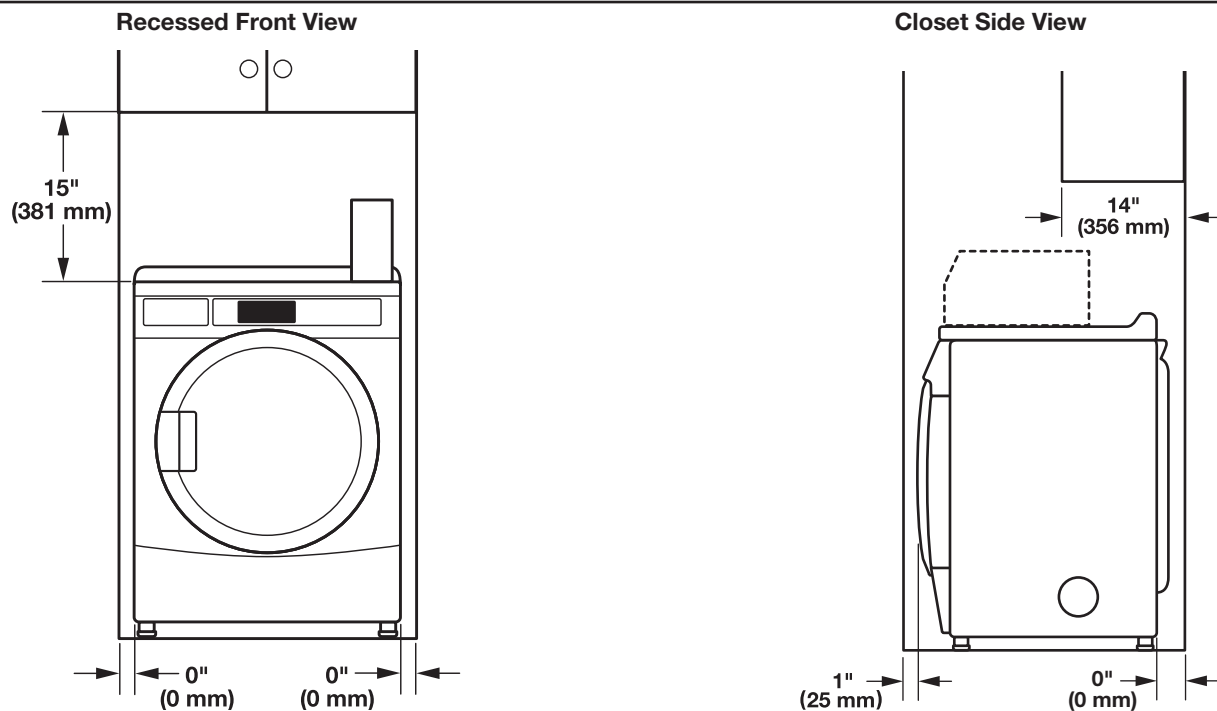

# INSTALLATION REQUIREMENTS

## Venting Requirements

**⚠ WARNING**



**Fire Hazard**

- Use a heavy metal vent.**
- Do not use a plastic vent.**
- Do not use a metal foil vent.**
- Failure to follow these instructions can result in death or fire.**

**WARNING:** To reduce the risk of fire, this dryer MUST BE EXHAUSTED OUTDOORS.

**IMPORTANT:** Observe all governing codes and ordinances.

Dryer exhaust must not be connected into any gas vent, chimney, wall, ceiling, attic, crawlspace, or a concealed space of a building. Only rigid or flexible metal vent shall be used for exhausting.

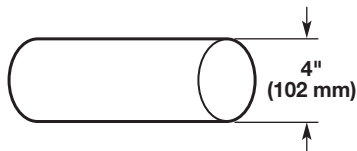

4" (102 mm) heavy, metal exhaust vent

- Only a 4" (102 mm) heavy, metal exhaust vent and clamps may be used.
- Do not use plastic or metal foil vent.

### Rigid metal vent:

- Recommended for best drying performance and to avoid crushing and kinking.

### Flexible metal vent: (Acceptable only if accessible to clean)

- Must be fully extended and supported in final dryer location.
- Remove excess to avoid sagging and kinking that may result in reduced airflow and poor performance.
- Do not install in enclosed walls, ceilings, or floors.
- The total length should not exceed 7¾ ft. (2.4 m).

**NOTE:** If using an existing vent system, clean lint from entire length of the system and make sure exhaust hood is not plugged with lint. Replace plastic or metal foil vents with rigid metal or flexible metal vents. Review "Vent System Chart" and if necessary, modify existing vent system to achieve best drying performance.

**NOTE:** Although each single-load dryer should typically have an unobstructed outdoor air opening of 24"² (154 cm²) (based on 1" [6.5 cm] per 1,000 Btu [252 kcal]), common make-up air openings are also acceptable.

Set up common openings so the make-up air is distributed equally to all dryers. Coverage area must be increased by 33% to account for the use of registers or louvers.

Make-up air openings should not be installed near the building exits for exhaust vents.

### Elbows:

- 45° elbows provide better airflow than 90° elbows.

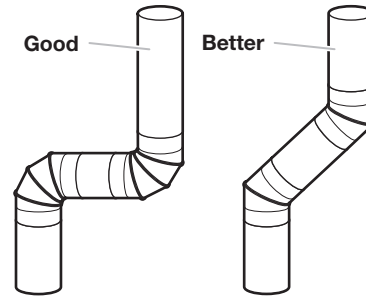

### Clamps:

- Use clamps to seal all joints.
- Exhaust vent must not be connected or secured with screws or other fastening devices that extend into interior of duct and catch lint. Do not use duct tape.

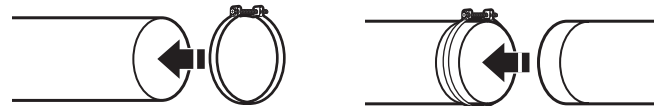

### Improper venting can cause moisture and lint to collect indoors, which may result in:

- Moisture damage to woodwork, furniture, paint, wallpaper, carpets, etc.
- Housecleaning problems and health problems.

# INSTALLATION REQUIREMENTS

## Vent Hoods

### 4" (102 mm) Diameter Exhaust Hoods

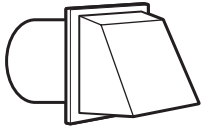

Box Hood

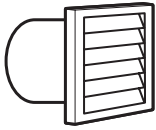

Louvered Hood

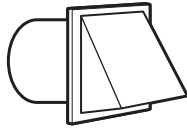

Angled Hood

Exhaust hood must be at least 12" (305 mm) from the ground or any object that may be in the path of the exhaust (such as flowers, rocks, bushes, or snow).

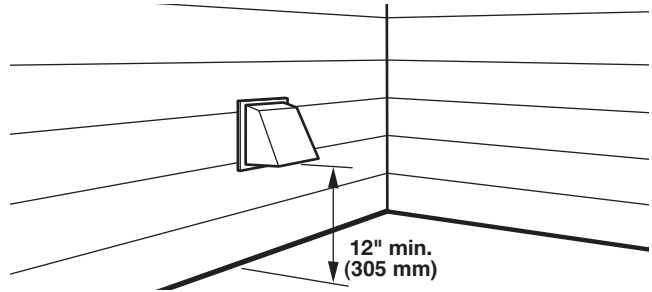

## Vent System Length

### Maximum Vent Length/Vent Connection

Maximum length of vent system depends upon the type of vent used, number of elbows, and type of exhaust hood.

Vent System Chart (Rigid Metal Vent)

No. of 90° Turns	Box and Louvered Hood	Angled Hood
0	64 ft. (19.5 m)	58 ft. (17.7 m)
1	54 ft. (16.5 m)	48 ft. (14.6 m)
2	44 ft. (13.4 m)	38 ft. (11.6 m)
3	35 ft. (10.7 m)	29 ft. (8.8 m)
4	27 ft. (8.2 m)	21 ft. (6.4 m)

For vent systems not covered by the vent specification chart, see your parts distributor.

Provision must be made for enough air for combustion and ventilation. (Check governing codes and ordinances.) See "Recessed Area and Closet Installation Instructions" in the "Location Requirements" sections.

A 4" (102 mm) outlet hood is preferred. However, a 2½" (64 mm) outlet exhaust hood may be used. A 2½" (64 mm) outlet creates greater back pressure than other hood types. For permanent installation, a stationary vent system is required.

### Connect Vent

1. If connecting to existing vent, make sure the vent is clean.
2. Using a 4" (102 mm) clamp, connect vent to exhaust outlet in dryer.

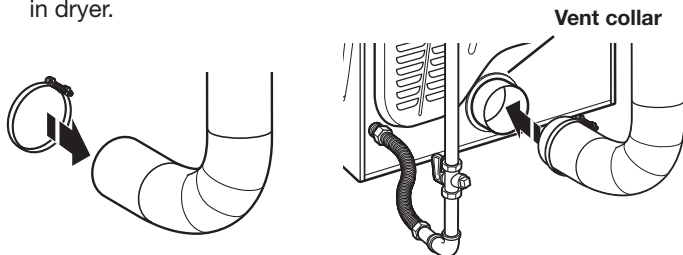

**NOTE:** Do not remove vent collar.

3. Tighten hose clamp with Phillips screwdriver.

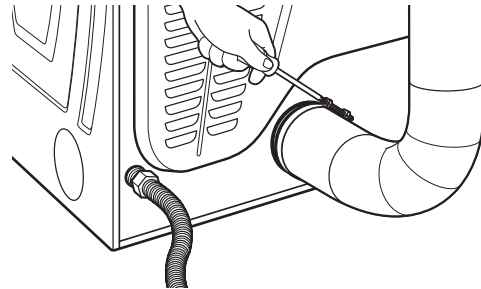

4. Make sure the vent is secured to exhaust hood with a 4" (102 mm) clamp.

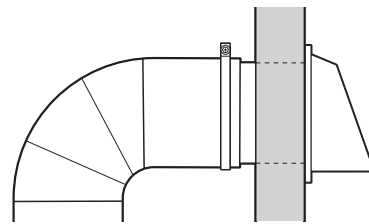

5. Move dryer into final position. Do not crush or kink vent. Make sure dryer is level.



# INSTALLATION REQUIREMENTS

## If an Exhaust Hood Cannot be Used

The outside end of main vent should have a sweep elbow directed downward.

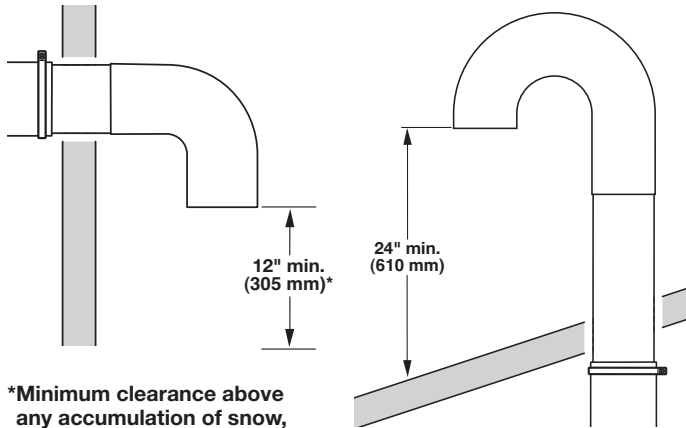

\*Minimum clearance above any accumulation of snow, ice, or debris such as leaves

If main vent travels vertically through the roof, rather than through wall, install a 180° sweep elbow on end of vent at least 2 ft. (610 mm) above surface of roof.

The opening in wall or roof shall have a diameter 1/2" (13 mm) larger than vent diameter. Vent should be centered in opening.

Do not install screening over end of vent for best performance.

## Multiple Dryer Venting

A main vent can be used for venting a group of dryers. The main vent should be sized to remove 5663 l/min. (200 CFM) of air per dryer. Large-capacity lint screens of proper design may be used in main vent if checked and cleaned frequently. The room where the dryers are located should have make-up air equal to or greater than CFM of all the dryers in the room.

Back-draft Damper Kit is available from your distributor and should be installed in the vent of each dryer to keep exhausted air from returning into dryers and to keep exhaust in balance within main vent. Unobstructed return air openings are required.

Each vent should enter the main vent at an angle pointing in the direction of the airflow. Vents entering from the opposite side should be staggered to reduce the exhausted air from interfering with the other vents.

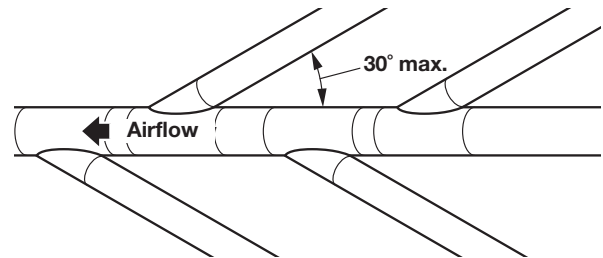

The maximum angle of each vent entering the main vent should be no more than 30°.

Keep air openings free of dry cleaning fluid fumes. Fumes create acids which, when drawn through the dryer heating units, can damage dryers and items being dried.

A clean-out cover should be located on the main vent for periodic cleaning of the vent system.

# INSTALLATION REQUIREMENTS

## Gas Dryer Installation Requirements

### Location Requirements

**⚠ WARNING**



**Explosion Hazard**

**Keep flammable materials and vapors, such as gasoline, away from dryer.**

**Do not install in a garage.**

**Failure to do so can result in death, explosion, or fire.**

Your dryer can be installed in a basement, laundry room, or recessed area.

This dryer is not intended for installation in a mobile home.

Companion appliance location requirements should also be considered.

**IMPORTANT:** Do not install or store the dryer where it will be exposed to water and/or the weather. Proper installation is your responsibility.

#### You will need:

- A grounded electrical outlet located within 6 ft. (1.8 m) of where the power cord is attached to the back of the dryer. See “Electrical Requirements.”
- A level floor with a maximum slope of 1" (25 mm) under entire dryer. Installing the dryer on soft floor surfaces, such as carpets or surfaces with foam backing, is not recommended.

#### Gas dryer installation clearances

- The location must be large enough to allow the dryer door to be fully opened.
- Additional spacing should be considered for ease of installation and servicing. The door opens more than 180°.
- Additional clearances might be required for wall, door, and floor moldings.
- Additional spacing of 1" (25 mm) on all sides of the dryer is recommended to reduce noise transfer.

#### When installing a gas dryer:

**IMPORTANT:** Observe all governing codes and ordinances.

- Check code requirements: Some codes limit or do not permit installation of clothes dryers in garages, closets, or sleeping quarters. Contact your local building inspector.
- Make sure that lower edges of the cabinet, plus the back and bottom sides of the dryer, are free of obstructions to permit adequate clearance of air openings for combustion air. See “Recessed Area and Closet Installation Instructions” below for minimum spacing requirements.

#### Recessed Area and Closet Installation Instructions

This dryer may be installed in a recessed area or closet. For recessed area and closet installations, minimum clearances can be found on the warning label on the rear of the dryer or in “Dimensions/Clearances.”

The installation spacing is in inches and is the minimum allowable. Additional spacing should be considered for ease of installation, servicing, and compliance with local codes and ordinances.

If closet door is installed, the minimum unobstructed air opening in the top and bottom is required. Louvered doors with equivalent air openings are acceptable.

The dryer must be exhausted outdoors.

No other fuel-burning appliance may be installed in the same closet as the dryer.

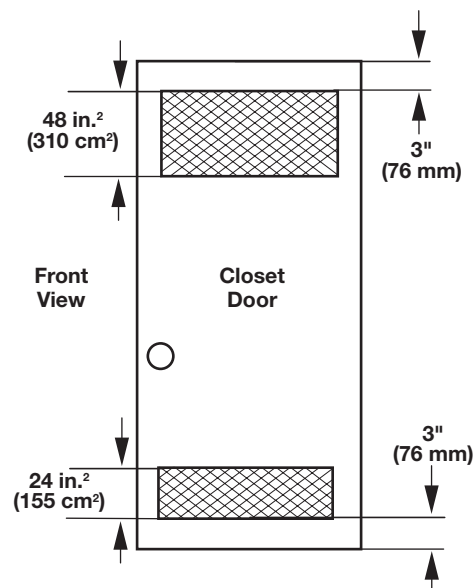

# INSTALLATION REQUIREMENTS

## Electrical Requirements

### **⚠ WARNING**



#### **Electrical Shock Hazard**

**Plug into a grounded 3 prong outlet.**

**Do not remove ground prong.**

**Do not use an adapter.**

**Do not use an extension cord.**

**Failure to follow these instructions can result in death, fire, or electrical shock.**

**IMPORTANT:** The dryer must be electrically grounded in accordance with local codes and ordinances or, in the absence of local codes, with the National Electrical Code, ANSI/NFPA 70, latest edition, or Canadian Electrical Code, CSA C22.1. If codes permit and a separate ground wire is used, it is recommended that a qualified electrical installer determine that the ground path is adequate.

A copy of the above code standards can be obtained from:

National Fire Protection Association  
One Batterymarch Park, Quincy, MA 02269

CSA International  
8501 East Pleasant Valley Road  
Cleveland, Ohio 44131-5575

- Do not ground to a gas pipe.
- Do not have a fuse in the neutral or ground circuit.
- A 120-volt, 60 Hz, AC-only, 15- or 20-amp, fused electrical circuit is required. A time-delay fuse or circuit breaker is also recommended. It is recommended that a separate circuit serving only this dryer be provided.
- This dryer is equipped with a power supply cord having a 3 prong grounding plug.
- To minimize the possibility of shock, the cord must be plugged into a mating, 3 prong, grounding-type outlet, grounded in accordance with local codes and ordinances. If a mating outlet is not available, it is the personal responsibility and obligation of the customer to have the properly grounded outlet installed by a qualified electrician.
- If codes permit and a separate ground wire is used, it is recommended that a qualified electrician determine that the ground path is adequate.
- Check with a qualified electrician if you are not sure the dryer is properly grounded.

## Gas Dryer Grounding

### **GROUNDING INSTRUCTIONS**

- For a grounded, cord-connected dryer:  
This dryer must be grounded. In the event of malfunction or breakdown, grounding will reduce the risk of electric shock by providing a path of least resistance for electric current. This dryer is equipped with a cord having an equipment-grounding conductor and a grounding plug. The plug must be plugged into an appropriate outlet that is properly installed and grounded in accordance with all local codes and ordinances.

**WARNING:** Improper connection of the equipment-grounding conductor can result in a risk of electric shock. Check with a qualified electrician or service representative or personnel if you are in doubt as to whether the dryer is properly grounded. Do not modify the plug provided with the dryer: if it will not fit the outlet, have a proper outlet installed by a qualified electrician.

### **SAVE THESE INSTRUCTIONS**

# INSTALLATION REQUIREMENTS

## Gas Supply

### **⚠ WARNING**



#### **Explosion Hazard**

**Use a new CSA International approved gas supply line.**

**Install a shut-off valve.**

**Securely tighten all gas connections.**

**If connected to propane, have a qualified person make sure gas pressure does not exceed 13" (330 mm) water column.**

**Examples of a qualified person include:**

**licensed heating personnel,  
authorized gas company personnel, and  
authorized service personnel.**

**Failure to do so can result in death, explosion, or fire.**

When installed above 10,000 feet (3048 m), a four percent (4%) reduction of the burner B.T.U. rating shown on the model/serial plate is required for each 1,000 foot (305 m) increase in elevation. For assistance when converting to other gas types and/or installing above 10,000 feet (3048 m) elevation, contact your local service company.

Gas supply pressure required to operate this dryer is a minimum of 5.2" wc (1.30 kPa) and a maximum of 10.5" wc (2.62 kPa).

**IMPORTANT:** Observe all governing codes and ordinances.

This installation must conform with all local codes and ordinances. In the absence of local codes, installation must conform with American National Standard, National Fuel Gas Code ANSI Z223.1/NFPA 54 or CAN/CSA B149.

A copy of the above code standards can be obtained from:

National Fire Protection Association  
One Batterymarch Park, Quincy, MA 02269

CSA International  
8501 East Pleasant Valley Road  
Cleveland, Ohio 44131-5575

The design of this dryer has been certified by CSA International for use at altitudes up to 10,000 feet (3048 m) above sea level at the B.T.U. rating indicated on the model/serial plate. Burner input adjustments are not required when the dryer is operated up to this elevation.

# INSTALLATION REQUIREMENTS

## Type of Gas

This dryer is equipped for use with natural gas. It is design-certified by CSA International for propane and butane gases with appropriate conversion. No attempt shall be made to convert dryer from gas specified on serial/rating plate for use with a different gas without consulting the serving gas supplier. Conversion must be done by a qualified service technician.

Gas conversion kit part number is W10402145. This number can also be found on a label on the gas valve burner base.

## Gas Supply Line

### Recommended Method

Provide a gas supply line of 1/2" (13 mm) rigid (IPS) pipe to dryer location. Pipe joint compounds that resist action of propane gas must be used. Do not use TEFLON<sup>†</sup> tape. With propane gas, piping or tubing size can be 1/2" (13 mm) minimum. Usually, propane gas suppliers determine size and materials used in the system.

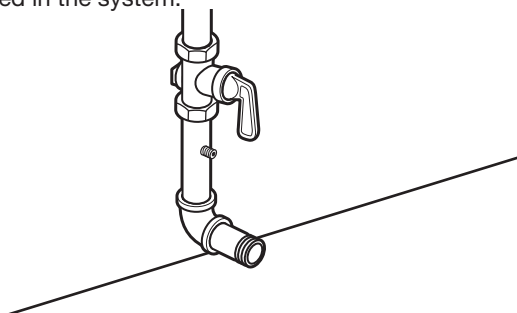

### Gas Supply Pressure Testing

A 1/8" NPT minimum plugged tapping, accessible for gauge testing, must be installed immediately downstream of the installed shut-off valve to the dryer (as shown above). The dryer must be disconnected from the gas supply piping system during any pressure testing of the system at test pressures in excess of 1/2" psig (352 kg/m<sup>2</sup>). The dryer must be isolated from the gas supply piping system by closing the equipment shut-off valve during any pressure testing of the gas supply piping system at test pressures equal to or less than 1/2" psig (352 kg/m<sup>2</sup>).

Expected Pressures For Gas Supply

	Minimum Inches of Water	Maximum Inches of Water
Natural Gas	5.2	10.5
Propane Gas	8.0	13.0

### Alternate Method

The gas supply may also be connected using 3/8" (10 mm) approved copper or aluminum tubing. If the total length of the supply line is more than 20 ft. (6.1 m), larger tubing will be required.

If using natural gas, do not use copper tubing. Pipe joint compounds that resist action of type of gas supplied must be used.

### Shut-off valve required

The supply line must be equipped with a manual shut-off valve installed within 6 ft. (1.8 m) of dryer in accordance with National Fuel Gas Code, ANSI Z223.1. This valve should be located in same room as dryer. It should be in a location that allows ease of opening and closing. Do not block access to shut-off valve. In Canada, an individual manual shut-off valve must be installed in accordance with the B149 installation codes CAN/CGA B149.1 and CAN/CGA B149.2.

### Flexible Metal Appliance Connector

It is recommended that a new flexible stainless steel gas line, design-certified by CSA International, be used for connecting the dryer to the gas supply line. (The gas pipe which extends through the lower rear of the dryer is provided with 3/8" male pipe thread.)

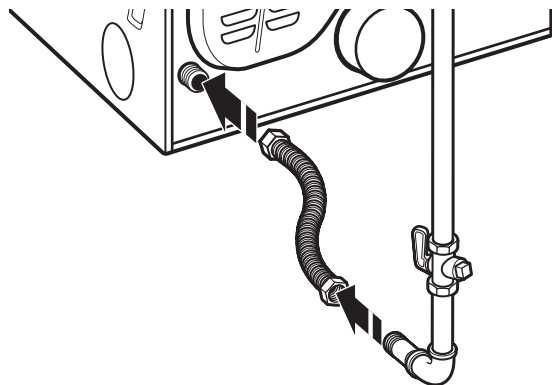

**NOTE:** Do not kink or damage the flexible stainless steel gas line when moving the dryer.

### Rigid Pipe Connection

The rigid pipe connection requires a combination of pipe fittings to obtain an in-line connection to the dryer.

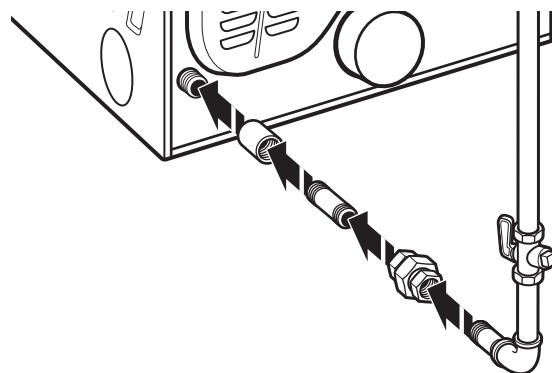

<sup>†</sup>TEFLON is a registered trademark of Chemours.

# INSTALLATION REQUIREMENTS

## Electric Dryer Installation Requirements

### Location Requirements

**⚠ WARNING**



**Explosion Hazard**

**Keep flammable materials and vapors, such as gasoline, away from dryer.**

**Do not install in a garage.**

**Failure to do so can result in death, explosion, or fire.**

Your dryer can be installed in a basement, laundry room, or recessed area.

This dryer is not intended for installation in a mobile home.

Companion appliance location requirements should also be considered.

**IMPORTANT:** Do not install or store the dryer where it will be exposed to water and/or the weather. Proper installation is your responsibility.

#### You will need:

- A grounded electrical outlet located within 6 ft. (1.8 m) of where the power cord is attached to the back of the dryer. See “Electrical Requirements.”
- A level floor with a maximum slope of 1" (25 mm) under entire dryer. Installing the dryer on soft floor surfaces, such as carpets or surfaces with foam backing, is not recommended.

#### Electric dryer installation clearances

- The location must be large enough to allow the dryer door to be fully opened.
- Additional spacing should be considered for ease of installation and servicing. The door opens more than 180°.
- Additional clearances might be required for wall, door, and floor moldings.
- Additional spacing of 1" (25 mm) on all sides of the dryer is recommended to reduce noise transfer.

#### Recessed Area and Closet Installation Instructions

This dryer may be installed in a recessed area or closet. For recessed area and closet installations, minimum clearances can be found on the warning label on the rear of the dryer or in “Dimensions/Clearances.”

The installation spacing is in inches and is the minimum allowable. Additional spacing should be considered for ease of installation, servicing, and compliance with local codes and ordinances.

If closet door is installed, the minimum unobstructed air opening in the top and bottom is required. Louvered doors with equivalent air openings are acceptable.

The dryer must be exhausted outdoors.

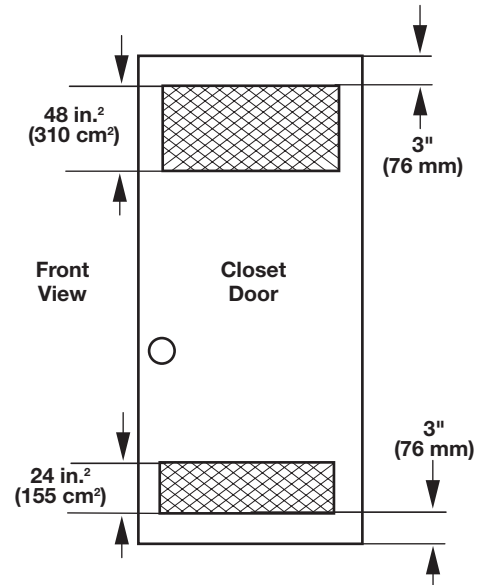

### Electrical Requirements – U.S.A. only

#### It is your responsibility:

- To contact a qualified electrical installer.
- To be sure that the electrical connection is adequate and in conformance with the National Electrical Code, ANSI/NFPA 70-latest edition and all local codes and ordinances.
- The National Electrical Code requires a 4-wire power supply connection for homes built after 1996, dryer circuits involved in remodeling after 1996, and all mobile home installations.
- A copy of the above code standards can be obtained from: National Fire Protection Association, One Batterymarch Park, Quincy, MA 02269.
- To supply the required 3- or 4-wire, single-phase, 120/240 volt, 60 Hz., AC-only electrical supply (or 3- or 4-wire, 120/208 volt electrical supply, if specified on the serial/rating plate) on a separate 30-amp circuit, fused on both sides of the line. A time delay fuse or circuit breaker is recommended. Connect to an individual branch circuit. Do not have a fuse in the neutral or grounding circuit.
- Do not use an extension cord.
- If codes permit and a separate ground wire is used, it is recommended that a qualified electrician determine that the ground path is adequate.

# INSTALLATION REQUIREMENTS

## Electrical Requirements – U.S.A. only (cont.)

### Electrical Connection

To properly install your dryer, you must determine the type of electrical connection you will be using and follow the instructions provided for it here.

- This dryer is manufactured ready to install with a 3-wire electrical supply connection. The neutral ground conductor is permanently connected to the neutral conductor (white wire) within the dryer. If the dryer is installed with a 4-wire electrical supply connection, the neutral ground conductor must be removed from the external ground connector (green screw), and secured under the neutral terminal (center or white wire) of the terminal block. When the neutral ground conductor is secured under the neutral terminal (center or white wire) of the terminal block, the dryer cabinet is isolated from the neutral conductor.
- If local codes do not permit the connection of a neutral ground wire to the neutral wire, see “Optional 3-wire connection” section.
- A 4-wire power supply connection must be used when the appliance is installed in a location where grounding through the neutral conductor is prohibited. Grounding through the neutral is prohibited for (1) new branch-circuit installations and (2) areas where local codes prohibit grounding through the neutral conductor.

### Electric Dryer Grounding

#### GROUNDING INSTRUCTIONS

- For a grounded, cord-connected dryer:  
This dryer must be grounded. In the event of malfunction or breakdown, grounding will reduce the risk of electric shock by providing a path of least resistance for electric current. This dryer uses a cord having an equipment-grounding conductor and a grounding plug. The plug must be plugged into an appropriate outlet that is properly installed and grounded in accordance with all local codes and ordinances.
- For a permanently connected dryer:  
This dryer must be connected to a grounded metal, permanent wiring system, or an equipment-grounding conductor must be run with the circuit conductors and connected to the equipment-grounding terminal or lead on the dryer.

**WARNING:** Improper connection of the equipment-grounding conductor can result in a risk of electric shock. Check with a qualified electrician or service representative or personnel if you are in doubt as to whether the dryer is properly grounded. Do not modify the plug on the power supply cord: if it will not fit the outlet, have a proper outlet installed by a qualified electrician.

**SAVE THESE INSTRUCTIONS**

### Electric Dryer Power Supply Cord

#### **WARNING**



#### Fire Hazard

- Use a new UL listed 30 amp power supply cord.**
- Use a UL listed strain relief.**
- Disconnect power before making electrical connections.**
- Connect neutral wire (white or center wire) to center terminal.**
- Ground wire (green or bare wire) must be connected to green ground connector.**
- Connect remaining 2 supply wires to remaining 2 terminals (gold).**
- Securely tighten all electrical connections.**
- Failure to do so can result in death, fire, or electrical shock.**

#### If using a power supply cord:

Use a UL-listed power supply cord kit marked for use with clothes dryers. The kit should contain:

- A UL-listed 30-amp power supply cord, rated 120/240 volt minimum. The cord should be type SRD or SRDT and be at least 4 ft. (1.22 m) long. The wires that connect to the dryer must end in ring terminals or “U”-shaped spade terminals with upturned ends.
- A UL-listed strain relief.

#### If your outlet looks like this:



**4-wire  
receptacle  
(14-30R)**

Then choose a 4-wire power supply cord with ring or spade terminals and UL-listed strain relief. The 4-wire power supply cord, at least 4 ft. (1.22 m) long, must have four 10-gauge copper wires and match a 4-wire receptacle of NEMA Type 14-30R. The ground wire (ground conductor) may be either green or bare. The neutral conductor must be identified by a white cover.

#### If your outlet looks like this:

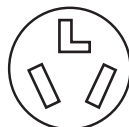

**3-wire  
receptacle  
(10-30R)**

Then choose a 3-wire power supply cord with ring or spade terminals and UL-listed strain relief. The 3-wire power supply cord, at least 4 ft. (1.22 m) long, must have three 10-gauge copper wires and match a 3-wire receptacle of NEMA Type 10-30R.

# INSTALLATION REQUIREMENTS

## Direct Wire

**⚠ WARNING**



**Fire Hazard**

**Use 10 gauge copper wire.**

**Use a UL listed strain relief.**

**Disconnect power before making electrical connections.**

**Connect neutral wire (white or center wire) to center terminal.**

**Ground wire (green or bare wire) must be connected to green ground connector.**

**Connect remaining 2 supply wires to remaining 2 terminals (gold).**

**Securely tighten all electrical connections.**

**Failure to do so can result in death, fire, or electrical shock.**

### If connecting by direct wire:

Power supply cable must match power supply (4-wire or 3-wire) and be:

- Flexible armored cable or nonmetallic sheathed copper cable (with ground wire), covered with flexible metallic conduit. All current-carrying wires must be insulated.
- 10-gauge solid copper wire (do not use aluminum).
- At least 5 ft. (1.52 m) long.

## Electrical Requirements – Canada only

**⚠ WARNING**



**Electrical Shock Hazard**

**Plug into a grounded 4 prong outlet.**

**Failure to do so can result in death or electrical shock.**

- Do not use an extension cord.

If you are using a replacement power supply cord, it is recommended that you use Power Supply Cord Replacement Part Number 8579325. For further information, please reference the service numbers located in the “Assistance or Service” section.

### It is your responsibility:

- To contact a qualified electrical installer.
- To be sure that the electrical connection is adequate and in conformance with the Canadian Electrical Code, C22.1 – latest edition and all local codes. A copy of the above codes standard may be obtained from: Canadian Standards Association, 178 Rexdale Blvd., Toronto, ON M9W 1R3 CANADA.
- To supply the required 4 wire, single phase, 120/240 volt, 60 Hz., AC-only electrical supply on a separate 30-amp circuit, fused on both sides of the line. A time-delay fuse or circuit breaker is recommended. Connect to an individual branch circuit.
- This dryer is equipped with a CSA International Certified Power Cord intended to be plugged into a standard 14-30R wall receptacle. The cord is 5 ft (1.52 m) in length. Be sure wall receptacle is within reach of dryer’s final location.



**4-wire  
receptacle  
(14-30R)**

## GROUNDING INSTRUCTIONS

- For a grounded, cord-connected dryer:  
This dryer must be grounded. In the event of malfunction or breakdown, grounding will reduce the risk of electric shock by providing a path of least resistance for electric current. This dryer is equipped with a cord having an equipment-grounding conductor and a grounding plug. The plug must be plugged into an appropriate outlet that is properly installed and grounded in accordance with all local codes and ordinances.

**WARNING:** Improper connection of the equipment-grounding conductor can result in a risk of electric shock. Check with a qualified electrician or service representative or personnel if you are in doubt as to whether the dryer is properly grounded. Do not modify the plug provided with the dryer: if it will not fit the outlet, have a proper outlet installed by a qualified electrician.

## SAVE THESE INSTRUCTIONS



# INSTALLING LEVELING LEGS, COIN SLIDE, AND COIN BOX

The coin slide mechanism, control panel lock and key, and coin box lock and key are not included and are available from usual industry sources. A special coin slide extension must be used on this model and can be purchased from the coin slide distributor.

## **⚠ WARNING**

### **Excessive Weight Hazard**

**Use two or more people to move and install dryer.**  
**Failure to do so can result in back or other injury.**

### **1. Prepare dryer for leveling legs**

**NOTE:** Slide dryer onto cardboard or hardboard before moving to avoid damaging floor covering.

Using two or more people, move dryer to desired installation location.

Take tape off front corners of dryer. Open dryer and remove the literature and parts packages. Wipe drum interior with damp cloth to remove any dust.

Take two cardboard corners from the dryer carton and place them on the floor in back of the dryer. Firmly grasp body of the dryer and gently lay it on its back on the cardboard corners.

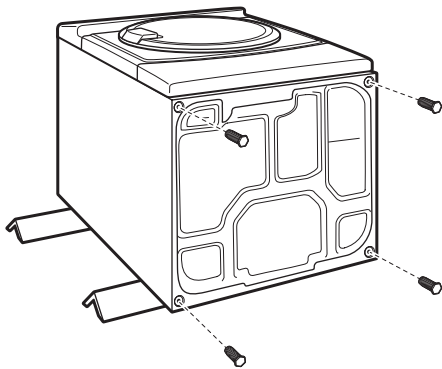
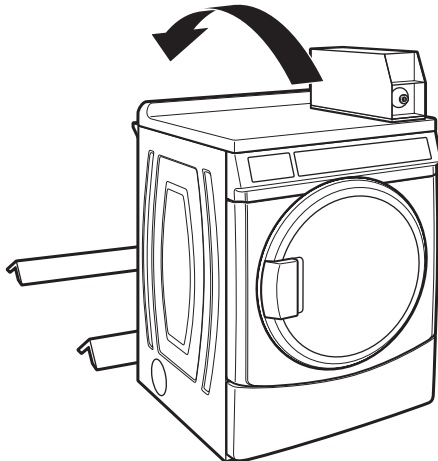

### **2. Screw in leveling legs**

Examine leveling legs and find diamond marking. Screw legs into leg holes by hand. Use an adjustable wrench or 1" (25 mm) hex-head socket wrench to finish turning legs until diamond marking is no longer visible. Then fit a covered foot boot over each leg foot. For floors with greater slopes, a longer leveling foot (part no. 279810) is available.

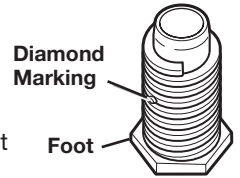

To protect the floor, use a large piece of cardboard from the dryer carton. Stand dryer up on the cardboard. Slide the dryer until it is close to its final location. Leave enough room for electrical connection and to connect the exhaust vent.

**On some models:** The meter case houses the factory-installed coin slide mechanism, service lock and key, and coin box lock and key.

### **3. Install coin slide and coin box**

Remove the service door of the meter case by lifting it up at the back. Install the money-accepting device. (Refer to manufacturer's instructions for proper installation.)

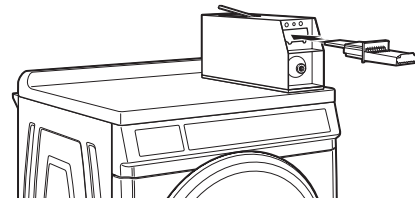

Replace the meter case service door. Put the coin vault with lock and key in the meter case opening.

Remove cardboard or hardboard from under dryer. Adjust the legs of the dryer up or down until the dryer is level.

# INSTALLATION INSTRUCTIONS – GAS DRYER

---

## Make Gas Connection

---

### **WARNING**

#### **Excessive Weight Hazard**

**Use two or more people to move and install dryer.**

**Failure to do so can result in back or other injury.**

1. Remove red cap from gas pipe on back of dryer.
2. Connect gas supply to dryer. Use a pipe thread compound approved for the type of gas supplied. If flexible metal tubing is used, be certain there are no kinks.  
If necessary for service, open the front lower service panel by using a 1/4" nutdriver to remove the 2 hex-head screws from the bottom of the panel. Then lift up on the panel while pulling the bottom of the panel away from the dryer.
3. Open the shut-off valve in the gas supply line and make sure the dryer has its own gas supply opened.
4. Test all connections by brushing on an approved noncorrosive leak-detection solution. Bubbles will show a leak. Correct any leaks found.

# INSTALLATION INSTRUCTIONS – ELECTRIC DRYER

## Electric Dryer Electrical Connections

### Strain Relief

#### Remove Terminal Block Cover

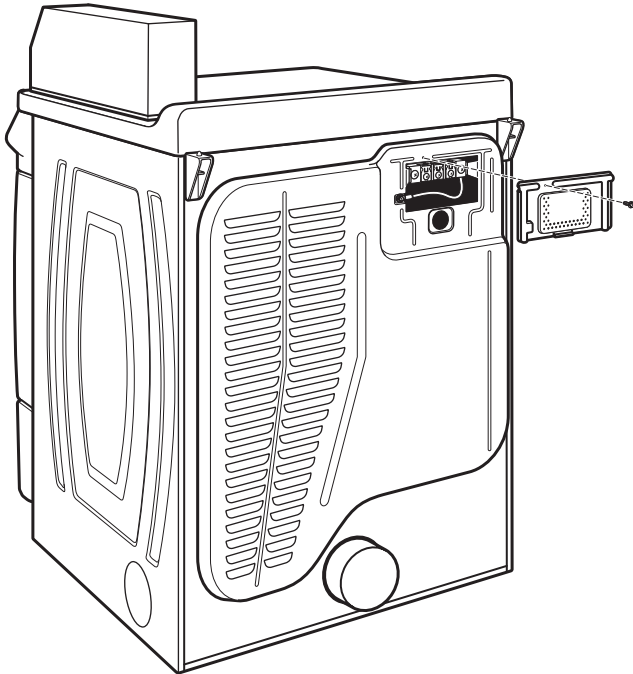

#### Direct Wire Strain Relief

1. Insert strain relief.

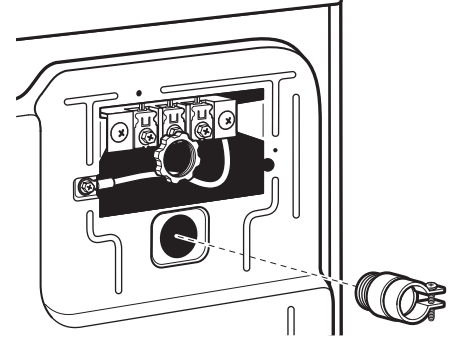

2. Insert conduit into strain relief and tighten clamp.

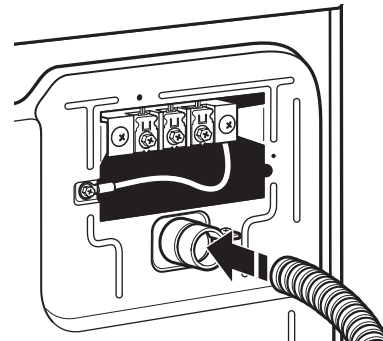

#### Power Supply Cord Strain Relief

1. Insert strain relief.

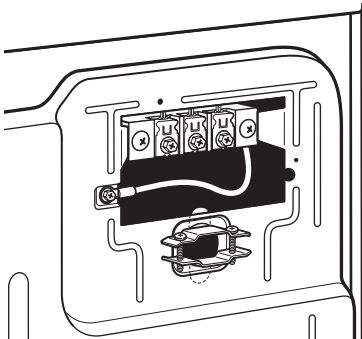

2. Insert power cord into strain relief.

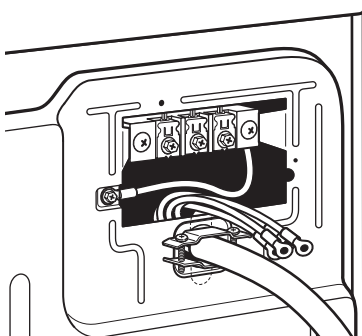

# INSTALLATION INSTRUCTIONS – ELECTRIC DRYER

## Connection Options

### Power Cord

4-wire receptacle (NEMA Type 14-30R)

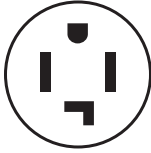

3-wire receptacle (NEMA Type 10-30R)



### Direct Wire

4-wire direct

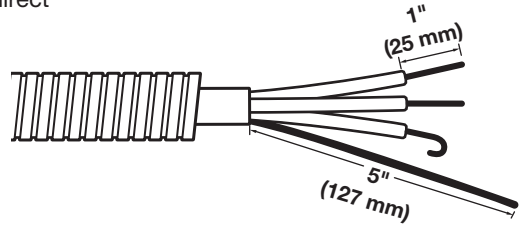

3-wire direct

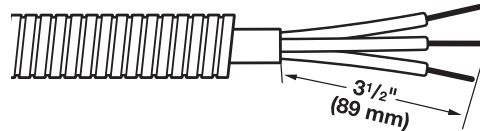

## Connecting 4-Wire Connection: Power Supply Cord

**IMPORTANT:** A 4-wire connection is required for mobile homes and where local codes do not permit the use of 3-wire connections.

### Standard Power Supply Cord Connectors



Flanged Spade Connector



Ring Connector

### Connecting Ground and Neutral Wires

1. Remove center terminal block screw and the ground wire by removing the external ground connector screw.

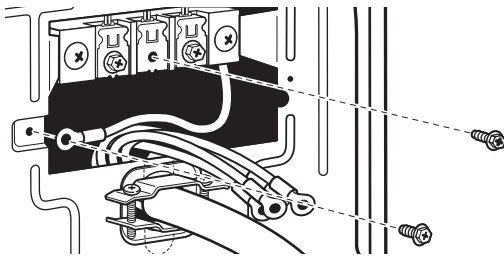

2. Connect ground and neutral wire to center terminal block.

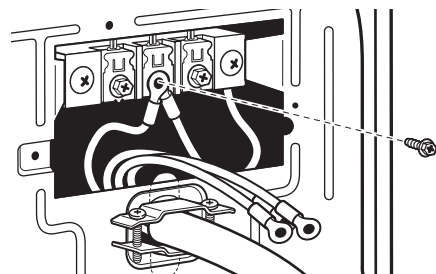

### Connecting Power Cord Ground Wire

3. Connect ground wire (green or bare) with external ground connector screw.

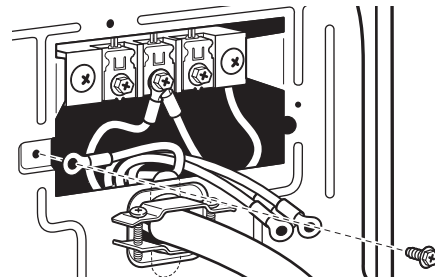

### Connecting Remaining Wires

4. Connect remaining wires with outer terminal block screws.

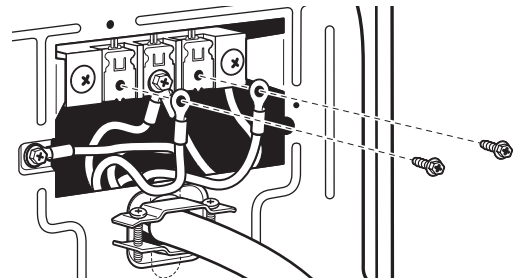

# INSTALLATION INSTRUCTIONS – ELECTRIC DRYER

## Connecting 3-Wire Connection: Power Supply Cord

### Standard Power Cord Connectors



Flanged Spade Connector



Ring Connector

### Connecting Neutral Wire

1. Loosen or remove center terminal block screw.

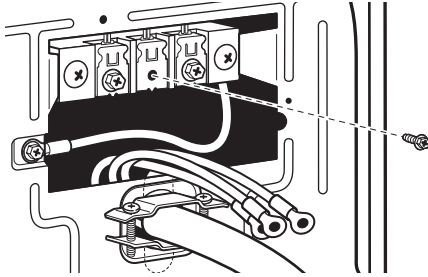

2. Connect neutral wire to center terminal block.

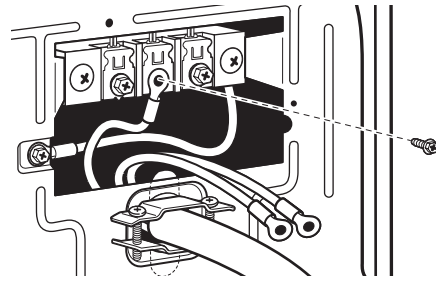

3. Connect remaining wires with outer terminal block screws.

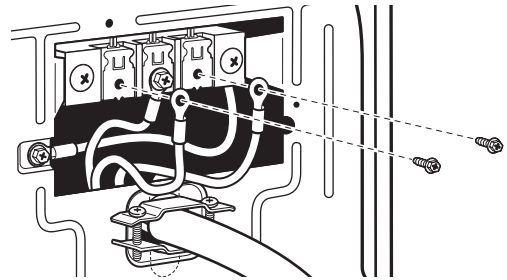

## Connecting 4-Wire Connection: Direct Wire

**IMPORTANT:** A 4-wire connection is required for mobile homes and where local codes do not permit the use of 3-wire connections.

Direct wire cable must have 5 ft. (1.52 m) of extra length so dryer can be moved if needed.

Strip 5" (127 mm) of outer covering from end of cable, leaving bare ground wire at 5" (127 mm). Cut 1½" (38 mm) from 3 remaining wires. Strip insulation back 1" (25 mm). Shape ends of wires into a hook shape.

### Connecting Ground and Neutral Wires

1. Remove center terminal block screw and the ground wire by removing the external ground connector screw.

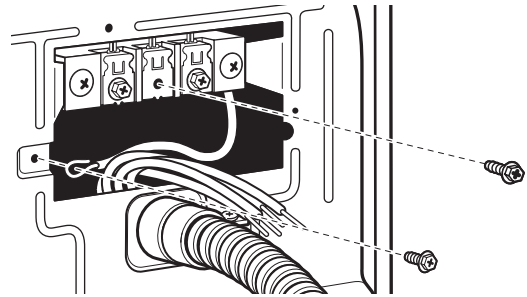

# INSTALLATION INSTRUCTIONS – ELECTRIC DRYER

## Connecting 4-Wire Connection: Direct Wire (cont.)

### Connecting Ground and Neutral Wires (cont.)

2. Connect ground and neutral wire to center terminal block.

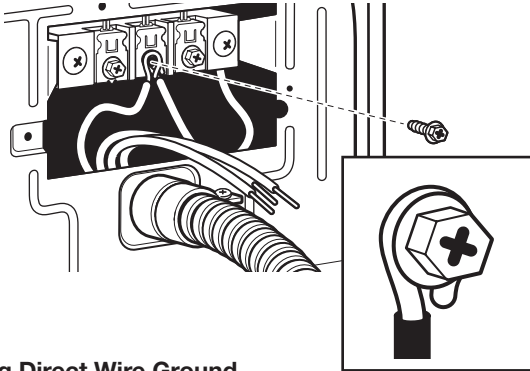

### Connecting Remaining Wires

4. Connect remaining wires to outer terminal block.

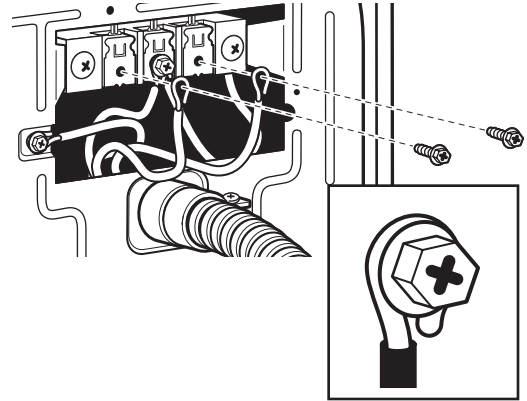

### Connecting Direct Wire Ground

3. Connect ground wire (green or bare) with external ground connector screw.

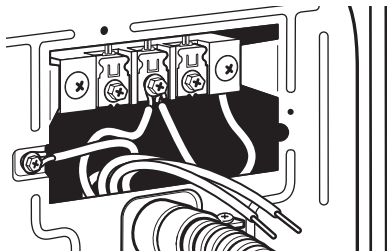

## Connecting 3-Wire Connection: Direct Wire

### Use where local codes permit connecting cabinet-ground conductor to neutral wire.

Direct wire cable must have 5 ft. (1.52 m) of extra length so dryer can be moved if needed.

Strip 3½" (89 mm) of outer covering from end of cable. Strip insulation back 1" (25 mm). If using 3-wire cable with ground wire, cut bare wire even with outer covering. Shape ends of wires into a hook shape.

### Connecting Neutral Wire

1. Loosen or remove center terminal block screw.

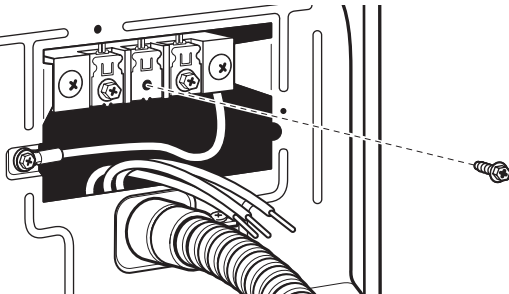

2. Connect neutral wire to center terminal block.

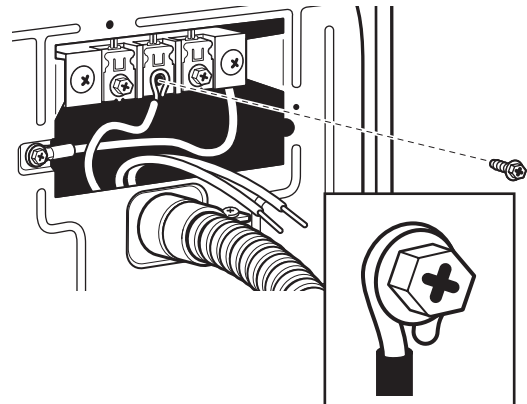

3. Connect remaining wires to outer terminal block.

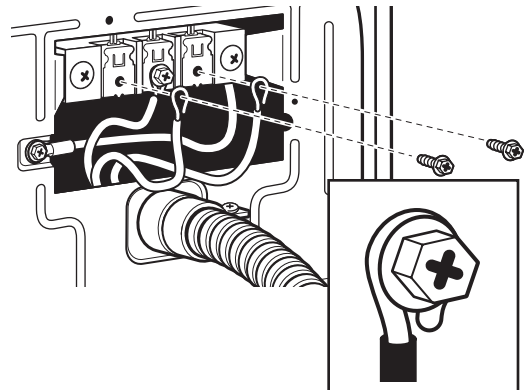

# INSTALLATION INSTRUCTIONS – ELECTRIC DRYER

## Connecting 3-Wire Connection: Optional

Use for direct wire or power supply cord where local codes do not permit connecting cabinet-ground conductor to neutral wire.

### Connecting Neutral Wire

1. Remove center terminal block screw. Also remove neutral ground wire by removing external ground conductor screw.

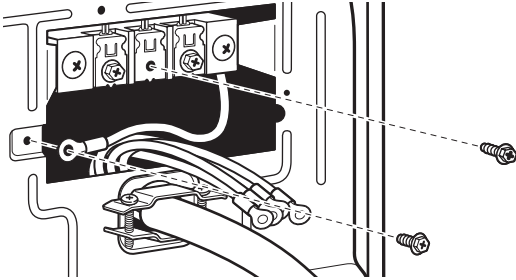

2. Connect neutral wire and neutral wire of power supply cord/cable to center terminal block.

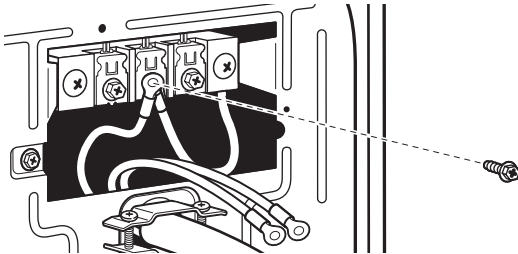

3. Connect remaining wires to outer terminal block.

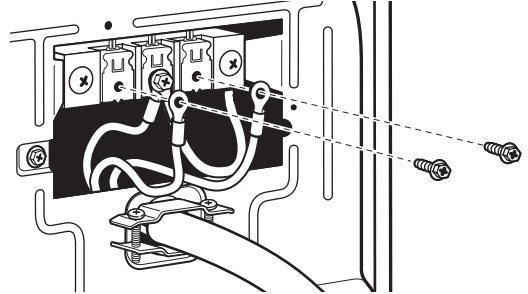

4. Connect a separate copper ground wire from the external ground conductor to an adequate ground.

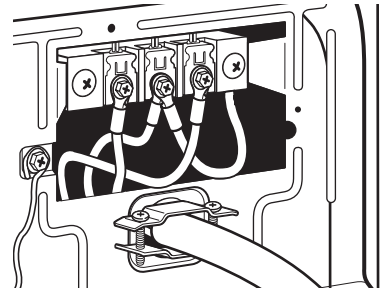

# LEVELING

Leveling your dryer properly reduces excess noise and vibration.

## **⚠ WARNING**

### **Excessive Weight Hazard**

**Use two or more people to move and install dryer.  
Failure to do so can result in back or other injury.**

1. Remove cardboard from beneath dryer. Place a level on top edges of dryer, checking each side and front. If not level, tip dryer and adjust feet up or down, repeating as necessary.

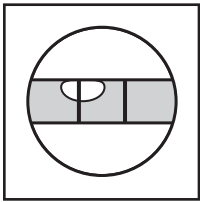
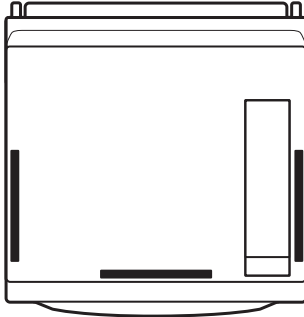

Not Level

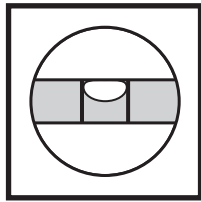

LEVEL

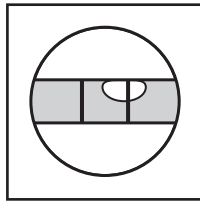

Not Level

2. Grip dryer from top and rock back and forth, making sure all four feet are firmly on floor. Repeat, rocking dryer from side to side. If dryer rocks, adjust leveling feet.

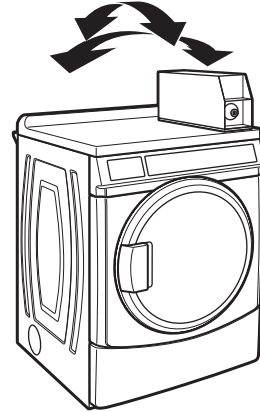

3. If dryer is not level, turn the leveling feet counterclockwise to lower the dryer or clockwise to raise the dryer. Recheck levelness of dryer and that all four feet are firmly in contact with the floor. Repeat as needed.

**HELPFUL TIP:** You may want to prop up front of dryer about 4" (102 mm) with a wood block or similar object that will support weight of dryer.

# COMPLETE INSTALLATION

1. Check the electrical requirements. Be sure that you have the correct electrical supply and the recommended grounding method. See "Electrical Requirements."
2. Check that all parts are now installed. If there is an extra part, go back through the steps.
3. Check that you have all of your tools.
4. Dispose of/recycle all packaging materials.

## **⚠ WARNING**



### **Electrical Shock Hazard**

**Plug into a grounded 3 prong outlet.  
Do not remove ground prong.  
Do not use an adapter.  
Do not use an extension cord.  
Failure to follow these instructions can result in death,  
fire, or electrical shock.**

6. Check dryer operation. Close dryer door. Insert coins in slide and press slide in slowly. Select the Whites and Colors cycle and let the dryer run for at least five minutes.

**NOTE:** Dryer door must be closed for dryer to operate.

7. Open the dryer door. Check that the inside of the dryer is warm. If the burner does not ignite and you can feel no heat inside the dryer, shut off dryer for five minutes. Check that all supply valve controls are in "ON" position and that the electrical cord is plugged in. Repeat five-minute test.
8. If drying time is too long, make sure that the lint screen is clean and that there are no obstructions to airflow in the dryer vent system.
9. Restart the dryer and allow it to complete a full cycle to make sure it is working properly.

5. Plug into a grounded outlet, or connect power.



# REVERSING DRYER DOOR SWING (OPTIONAL)

## Remove the Door Assembly

1. Place a towel or soft cloth on top of dryer or work space to avoid scratching of the surface.
2. Remove 3 of the 4 screws that hold the door hinge on the front panel of the dryer. Partially loosen the remaining screw with keyhole opening and lift the door off the screw.

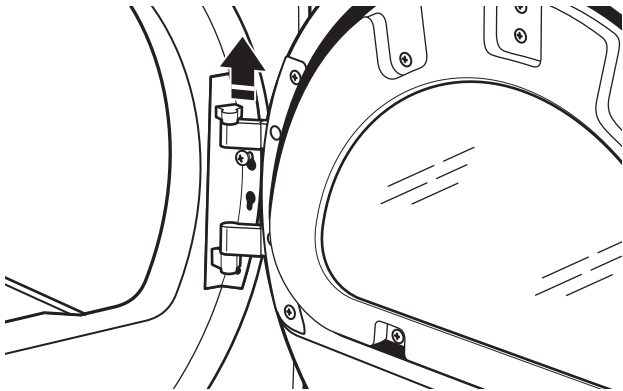
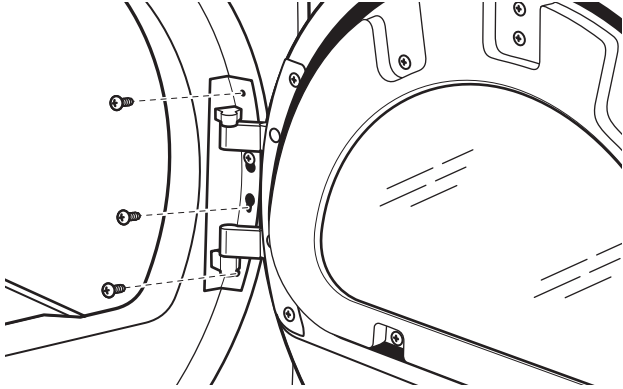

3. Lay the door assembly on a previously prepared flat surface with the inside (inner door assembly) facing up, and remove 6 Phillips-head screws to release outer door assembly from inner door assembly.

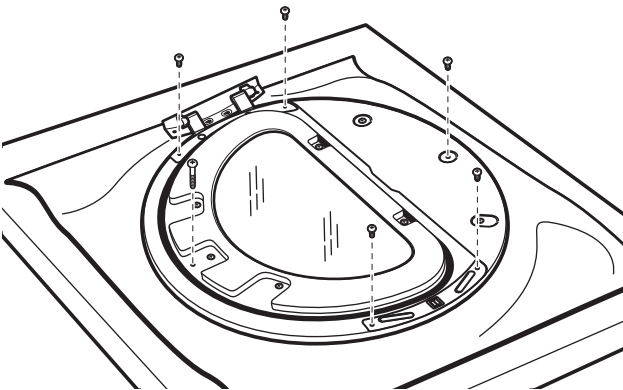

**NOTE:** It is important that you remove only the 6 indicated screws.

4. Lift the inner door assembly off outer door assembly.

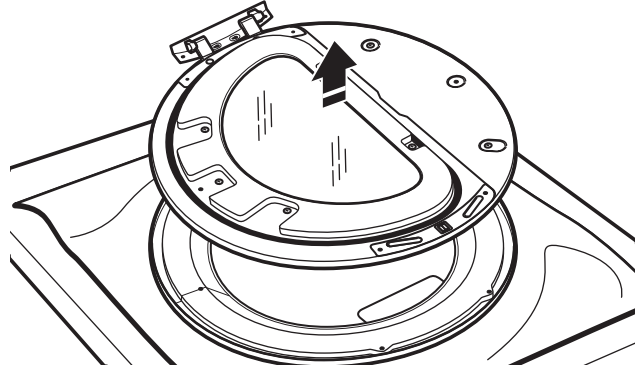

5. Remove 4 Phillips-head screws to release center insert from outer door ring.

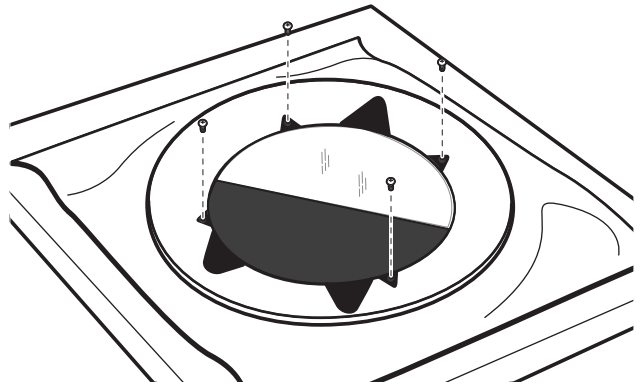

6. Lift and rotate center insert 180 degrees.

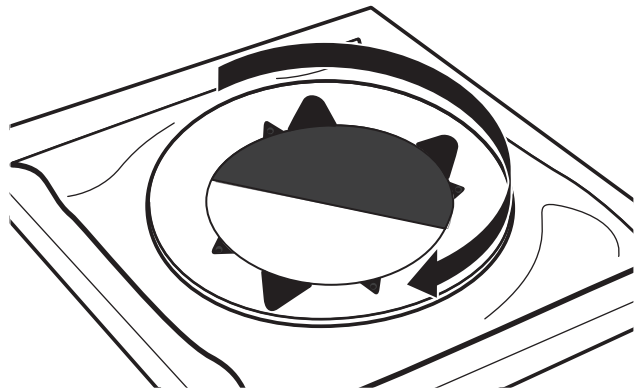

7. Reassemble the center insert and outer door ring with the 4 screws

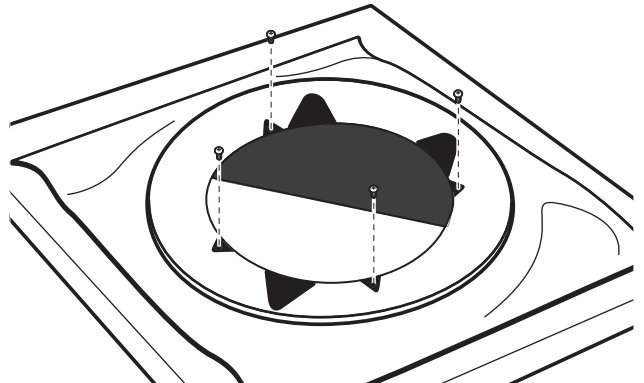

# REVERSING DRYER DOOR SWING (OPTIONAL)

## Reverse Hinge

1. Use a small flat-blade screwdriver to remove 2 plug strips from the inner door. Slide the head of the screwdriver under the plugs, without scratching inner door surface, and lift up strip.

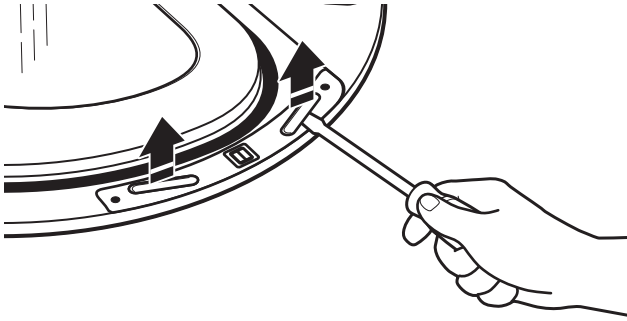

2. Remove the 4 screws that attach to inner door hinge.

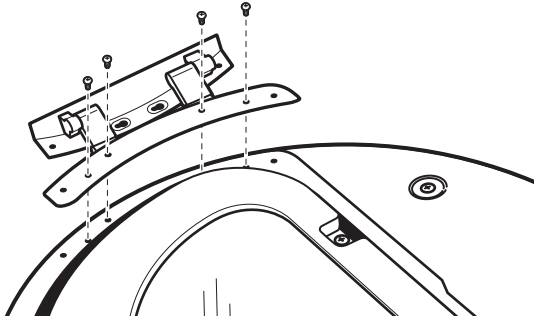

3. Move hinge to other side. Reinstall 4 screws.

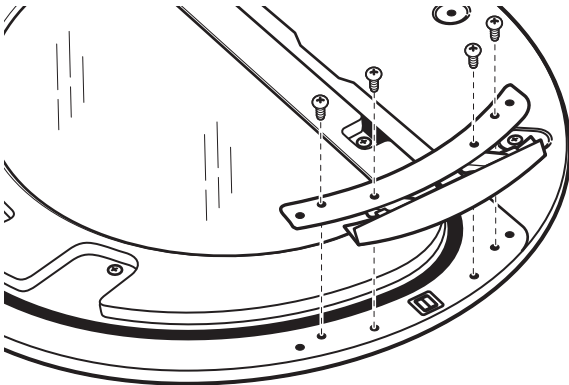

4. Reinstall plug strips on opposite side of the inner door.

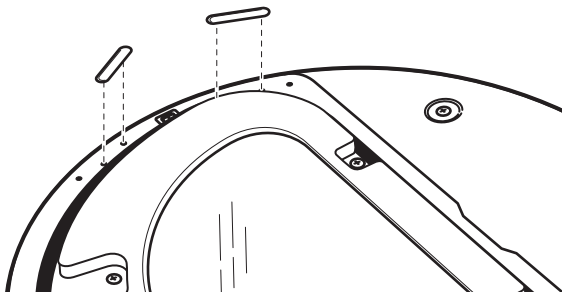

5. Check for fingerprints on the glass. Clean if necessary.

## Replace the Door Assembly

1. Place the inner door assembly inside the outer door assembly.

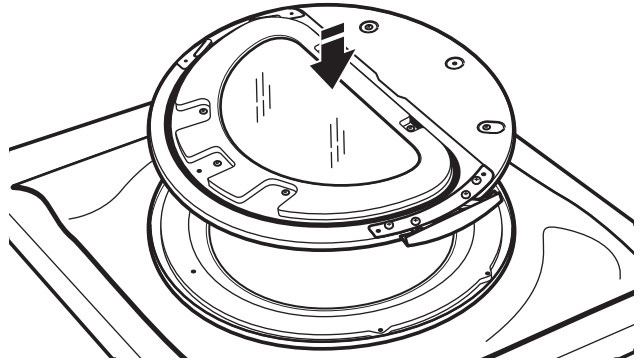

2. Reassemble the inner and outer door assemblies with the 6 screws.

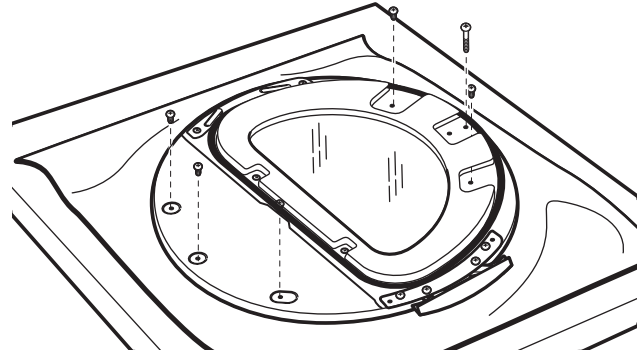

## Reverse the strike

1. Use a small flat-blade screwdriver to remove plug strip from the dryer door opening. Slide the head of the screwdriver under the plugs, without scratching dryer surface, and lift up strip.

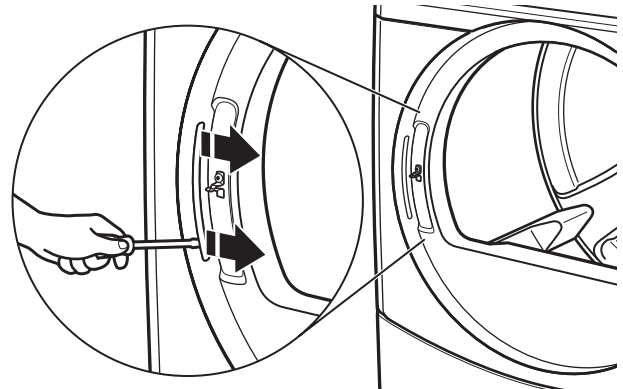

2. Remove the strike using a Phillips screwdriver.

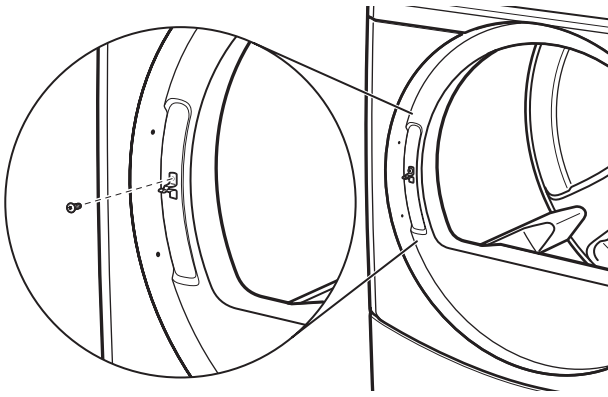

3. Insert strike on the opposite side.

### Reinstall the door

1. Partially insert the third screw from the top; then slide the hinge onto this screw while hooking the hinge into the front panel hole. Reattach door to dryer front panel with the remaining three screws.

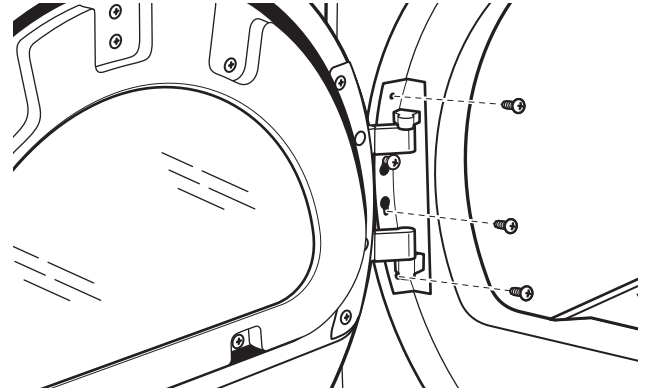

2. Check for fingerprints on the glass. Clean if necessary.  
3. Close door and check that it latches securely.

## MAINTENANCE INSTRUCTIONS

- Clean lint screen before and after each cycle.
- Removing accumulated lint:
  - From inside the dryer cabinet:  
Lint should be removed every 2 years or more often, depending on dryer usage. Cleaning should be done by a qualified person.
  - From the exhaust vent:  
Lint should be removed every 2 years, or more often, depending on dryer usage.
- Keep area around dryer clear and free from combustible materials, gasoline, and other flammable vapors and liquids.
- Keep dryer area clear and free of items that would obstruct the flow of combustion and ventilation air.

### If dryer does not operate, check the following:

- Electrical supply is connected.
- Circuit breaker is not tripped or house fuse is not blown.
- Door is closed. Listen closely to hear the door switch activate.
- Control is set up properly and display shows cycle time.
- Cycle selection button has been pushed firmly.
- For gas dryers, check that gas supply shut-off valves are set in open position.

## IF YOU NEED ASSISTANCE

If you need service, all warranty service is provided exclusively by our authorized Whirlpool Service Providers. In the U.S. and Canada, direct all requests for warranty service to: Whirlpool Customer Experience Center.

In the U.S.A. call **1-800-253-1301**. In Canada call **1-800-807-6777**.

If outside the 50 United States and Canada, contact your authorized Whirlpool dealer to determine if another warranty applies.

# ELECTRONIC CONTROL SETUP INSTRUCTIONS

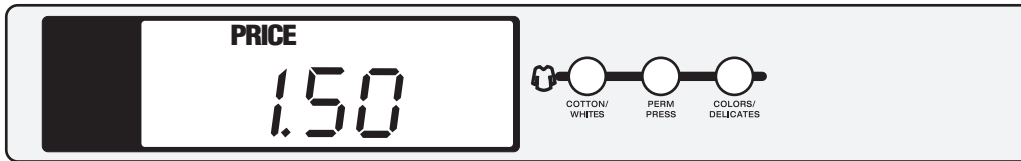

**NOTE:** After the dryer has been installed and plugged in, the display will show “0 MINUTES.” After the door has been opened and closed, the display will show the vend price.

## General User Information

### SCROLLING “OUT OF ORDER” MESSAGE, FOLLOWED BY A FAILURE OR DIAGNOSTIC CODE, SHOWING IN DISPLAY –

This condition indicates the dryer is inoperative.

**“0 MINUTES” SHOWING IN DISPLAY –** This indicates the dryer cannot be operated. Coins dropped or debit inputs during this condition will be stored in escrow but cannot be used until normal operation is restored by opening and closing the door. If a door switch has failed, causing “0 MINUTES” to remain in the display after the door is opened and closed, it must be replaced before normal operation can be restored.

**COLD START (Initial first use) –** Dryer is programmed at the factory as follows: \$1.50 dry price (30 minutes).  
9160 model only: \$0 dry price (45 minutes)

**WARM START (after power failure) –** A few seconds after power is restored, if a cycle was in progress at the time of the power failure, “RESELECT CYCLE” will flash in the display, indicating the need for a fabric setting button to be pressed to restart dryer.

**PRICING –** After the door is opened and then closed following the completion of a cycle, the display indicates the cycle price (unless set for free operation, where the display will flash “SELECT CYCLE”). As coins are dropped or debit inputs arrive, the display will change to lead the user through the initiation of a cycle.

### There are four (4) types of dryer pricing:

#### Fixed “Vend” Pricing

A dryer setup for “Fixed Cycle” operation can only accept additional time accumulated by increments equal to the length of a complete dry cycle. A maximum of 99 minutes may be purchased; no additional credit is given for coins dropped with 99 minutes in the display.

#### Accumulator Pricing

If option d is set to d. 00, and the 6 code is set to one coin 1, then accumulator pricing is in effect. Cycle time can be purchased one coin at a time up to the maximum time of 99 minutes.

### Fixed Cycle With Top Off Pricing (available for use with coin drops or card readers only)

A dryer set to offer “Top Off” capability will allow time to be added to an existing dry cycle in increments equal to the number of minutes of dry time per quarter (coin 1), up to 99 minutes, regardless of the cost required to start the dryer. No credit is given for coins or debit inputs entered when the control is displaying 99 minutes.

**FREE CYCLES –** This is established by setting the cycle price to zero. When this happens, “SELECT CYCLE” will appear rather than a cycle price. Any cycle started as a free cycle will automatically terminate when the door is opened.

**DEBIT CARD READY –** This dryer is debit card ready. It will accept a variety of debit card systems, but does NOT come with a debit card reader. Refer to the debit card reader manufacturer for proper dryer setup. When a Generation 2 card reader is installed, the dryer is placed in enhanced debit mode.

In Enhanced Debit Mode, the top off price can be set independently (see VALUE OF COIN 2), and the top off time is calculated according to the following equation:

$$\frac{\text{top off price}}{\text{full cycle price}} = \frac{\text{top off time}}{\text{full cycle length}}$$

In models converted to a Generation 1 debit card system, debit pulses represent the equivalent of one coin (coin 1).

**NOTE:** Enhanced debit mode cannot be deselected.

## Control Set-up Procedures

**IMPORTANT:** Read all instructions before operating.

The fabric setting buttons along with the digital display are used to set up the dryer controls.

The display can contain 4 numbers and/or letters and a decimal point. These are used to indicate the set-up codes and related code values available for use in programming the dryer.

# ELECTRONIC CONTROL SETUP INSTRUCTIONS

## How to Use the Buttons to Program the Controls

1. The COTTON/WHITES button is used to adjust the values associated with set-up codes. Pressing the button will change the value by increments. Rapid adjustment is possible by holding down the button.
2. The PERM PRESS button will advance through the set-up codes. Pressing this button will advance to the next available set-up code. Holding down the button will automatically advance through the set-up codes at a rate faster than 1 per second.
3. The COLORS/DELICATES button is used to select or deselect options.

## Start Operating Setup

Insert service access door key, turn, and lift to remove service access door.

### Dryers with Card Reader Installed:

Once the debit card reader is installed (according to the reader manufacturer's instructions), the set-up mode can be entered by inserting a manual set-up card (supplied by the reader manufacturer) into the card slot. If manual set-up card is not available, only the diagnostic mode can be entered by removing the service access door.

**IMPORTANT:** To access set-up mode or diagnostic mode, use a service key (9050 models) to open the service access door. If a card reader is installed, a service card is available for accessing diagnostics. If a service key is not available (9060 models), the AA1 connector must be removed or the Service Access Code described below must be used. The console must not be opened unless power is first disconnected from the dryer. To access connector AA1:

1. Unplug dryer or disconnect power.
2. Open console, remove plug on AA1, and close console.
3. Plug in dryer or reconnect power.

The dryer is now in the set-up mode.

To enter the alternative Service Access Code and enter set-up mode: Press the Left Button, Right Button, Left Button, Right Button, and Right Button.

**NOTE:** It is not necessary to set up the dryer with the following codes; the dryer is pre-set at the factory. These codes can be used to change settings, if desired.

## Set-Up Codes

- The PERM PRESS button will advance from code to code.
- The COTTON/WHITES button will change the code value.
- The COLORS/DELICATES button will select or deselect options.

The set-up code is indicated by the one or two left-hand characters. The set-up code value is indicated by the two or three right-hand characters.

**NOTE:** The first line of each code indicates the factory default.

Code	Explanation
<b>6. 06 REGULAR CYCLE PRICE</b>	
6. 06	When the d.xx is set to d.00, this 6.xx value represents the number of coins (coin 1) needed to start the dryer; may adjust from 0–39. Change this value by pressing the COTTON/WHITES button. 6.06 = 6 coins = \$1.50. (9160 models default to 6.00.)
6. 01	When the d.xx is set to d.CS, this 6.xx value represents the number of push-in actuations of the coin slide to start the dryer. 6.01 would equal one coin slide activation. <ul style="list-style-type: none"> <li>• Press the PERM PRESS button once to advance to next code.</li> </ul>
<b>7. 05 REGULAR DRY TIME</b>	
7. 05	When set to Coin Drop or Card Reader operation, the dry time equals the Regular Dry Time value multiplied by the Regular Cycle Price value. Example: 6.06 and 7.05 = (06 x 05 = 30 minutes).
7. 45	For coinslide or OPL operation, the value is the amount of minutes of dry time. Factory default of 45 minutes. Pressing COTTON/WHITES adjusts the value from 1–99 minutes. <ul style="list-style-type: none"> <li>• Press the PERM PRESS button once to advance to next code.</li> </ul>
<b>8. 00 TYPE OF DRYER PRICING</b>	
8. 00	Fixed Cycle with Top Off. Only available for use with coin drops or card readers. For detailed description, see “General User Information.”
8. FC	Fixed Cycle. For detailed description, see General User Information. Use COLORS/DELICATES button to make this selection. <ul style="list-style-type: none"> <li>• Press the PERM PRESS button once to advance to next code.</li> </ul>
<b>9. 00 CYCLE COUNTER OPTION</b>	
This option is either NOT SELECTED “OFF” or SELECTED “ON.”	
9. 00	Not Selected “OFF.”
9. 0C	Selected “ON” and not able to be deselected. <ul style="list-style-type: none"> <li>• Press the COLORS/DELICATES button 3 consecutive times to select “ON.” Once selected “ON” it cannot be deselected.</li> <li>• Press the PERM PRESS button once to advance to next code.</li> </ul>
<b>1. 00 MONEY COUNTER OPTION</b>	
This option is either NOT SELECTED “OFF” or SELECTED “ON.”	
1. 00	Not Selected “OFF.”
1. 0C	Selected “ON.” <ul style="list-style-type: none"> <li>• Press the COLORS/DELICATES button 3 consecutive times to select “ON” and 3 consecutive times to deselect (Not Selected “OFF”). Counter resets by going from “OFF” to “ON.”</li> </ul>
1. C0	Selected “ON” and not able to be deselected. <ul style="list-style-type: none"> <li>• To select “ON” and not able to be deselected, first select “ON;” then within 2 seconds press the COLORS/DELICATES button twice, the COTTON/WHITES button once, and exit set-up mode.</li> <li>• Press the PERM PRESS button once to advance to next code.</li> </ul>

# ELECTRONIC CONTROL SETUP INSTRUCTIONS

Code	Explanation
2. 00	<b>SPECIAL PRICING OPTIONS</b> This option is either SELECTED 'ON' or NOT SELECTED 'OFF'.
2. 00	Not Selected 'OFF'.
2. SP	Selected 'ON'. Press the COLORS/DELICATES button once for this selection. <b>If SPECIAL PRICING OPTION is selected, there is access to codes '3.' thru '9.'</b> • Press the PERM PRESS button once to advance to next code.
<b>OPTIONS TO USE IF SPECIAL PRICING IS SELECTED:</b>	
3. 06	<b>SPECIAL CYCLE PRICE</b>
3. 06	Represents the number of quarters (coin 1) needed to start the dryer; may adjust from 0–39. (See b.xx setup for VALUE OF COIN 1). Advance from 0–39 by pressing the COTTON/WHITES button. Factory default of 6 quarters = \$1.50.
3. 00	Model 9160: Factory default of 0 quarters. • Press the PERM PRESS button once to advance to next code.
4. 05	<b>SPECIAL DRY TIME</b>
4. 05	Model 9150: Represents the number of minutes per quarter (coin 1). Factory default of 5 minutes per coin. Example: 6 quarters x 5 minutes = 30 minutes. By pressing the COTTON/WHITES button, the value can be adjusted from 1–99 minutes.
4. 45	Model 9160: Represents the fixed cycle time in minutes. As example: '4.45' = 45 minutes. • Press the PERM PRESS button once to advance to next code.
5. 00	<b>TIME-OF-DAY CLOCK, MINUTES</b>
5. 00	This is the TIME-OF-DAY CLOCK, minute setting; select 0–59 minutes by pressing the COTTON/WHITES button. • Press the PERM PRESS button once to advance to next code.
6. 00	<b>TIME-OF-DAY CLOCK, HOURS</b> <b>NOTE:</b> Uses military time – 24 hr. clock.
6. 00	This is the TIME-OF-DAY CLOCK, hour setting; select 0–23 hours by pressing the COTTON/WHITES button. • Press the PERM PRESS button once to advance to next code.
7. 00	<b>SPECIAL PRICE START HOUR</b> <b>NOTE:</b> Uses military time – 24 hr. clock.
7. 00	This is the start hour; select 0–23 hours. Select START HOUR by pressing the COTTON/WHITES button. • Press the PERM PRESS button once to advance to next code.

Code	Explanation																								
8. 00	<b>SPECIAL PRICE STOP HOUR</b> <b>NOTE:</b> Uses military time – 24 hr. clock.																								
8. 00	This is the stop hour; select 0–23 hours. Select STOP HOUR by pressing the COTTON/WHITES button. • Press the PERM PRESS button once to advance to next code.																								
9. 10	<b>SPECIAL PRICE DAY</b>																								
9. 10	This represents the day of the week and whether special pricing is selected for that day. A number followed by '0' indicates no selection for that particular day (9.10). A number followed by an 'S' indicates selected for that day (9.1S). Day of week (1–7) can be chosen by pressing the COTTON/WHITES button. Press the COLORS/DELICATES button once to select special pricing for each day chosen. When exiting set-up code '9.', the display must show current day of week:																								
	<table border="1"> <thead> <tr> <th>DISPLAY</th> <th>DAY OF WEEK</th> <th>CODE (selected)</th> </tr> </thead> <tbody> <tr> <td>10</td> <td>Day 1 = Sunday</td> <td>1S</td> </tr> <tr> <td>20</td> <td>Day 2 = Monday</td> <td>2S</td> </tr> <tr> <td>30</td> <td>Day 3 = Tuesday</td> <td>3S</td> </tr> <tr> <td>40</td> <td>Day 4 = Wednesday</td> <td>4S</td> </tr> <tr> <td>50</td> <td>Day 5 = Thursday</td> <td>5S</td> </tr> <tr> <td>60</td> <td>Day 6 = Friday</td> <td>6S</td> </tr> <tr> <td>70</td> <td>Day 7 = Saturday</td> <td>7S</td> </tr> </tbody> </table>	DISPLAY	DAY OF WEEK	CODE (selected)	10	Day 1 = Sunday	1S	20	Day 2 = Monday	2S	30	Day 3 = Tuesday	3S	40	Day 4 = Wednesday	4S	50	Day 5 = Thursday	5S	60	Day 6 = Friday	6S	70	Day 7 = Saturday	7S
DISPLAY	DAY OF WEEK	CODE (selected)																							
10	Day 1 = Sunday	1S																							
20	Day 2 = Monday	2S																							
30	Day 3 = Tuesday	3S																							
40	Day 4 = Wednesday	4S																							
50	Day 5 = Thursday	5S																							
60	Day 6 = Friday	6S																							
70	Day 7 = Saturday	7S																							
	• Press the PERM PRESS button once to advance to next code.																								
A. 00	<b>VAULT VIEWING OPTION</b> This option is either SELECTED 'ON' or NOT SELECTED 'OFF'.																								
A. 00	Not Selected 'OFF'.																								
A. SC	Selected 'ON'. Press the COLORS/DELICATES button once for this selection. When selected, the money and/or cycle counts will be viewable (if counting is selected) when the coin box is removed. • Press the PERM PRESS button once to advance to next code.																								
b. 05	<b>VALUE OF COIN 1</b>																								
b. 05	This represents the value of coin 1 in number of nickels: 05 = \$0.25 (default for 9150 and 9160 models). • By pressing the COTTON/WHITES button, there is an option of 1–199 nickels. • Press the PERM PRESS button once to advance to next code.																								
b. 30	With coin slide activation, this represents the total vend price in nickels. Example: b.30 is equal to \$1.50.																								

# ELECTRONIC CONTROL SETUP INSTRUCTIONS

Code	Explanation
C. 20	<b>VALUE OF COIN 2</b>
C. 20	This represents the value of coin 2 in number of nickels: 20 = \$1.00. <ul style="list-style-type: none"> <li>By pressing the COTTON/WHITES button, there is an option of 1–199 nickels.</li> </ul>
C. 05	When a Gen 2 card reader is used, this code represents the value of top off in nickels. C.05 = \$0.25. <ul style="list-style-type: none"> <li>Press the PERM PRESS button once to advance to next code.</li> </ul>
d. 00	<b>COIN SLIDE OPTION</b> This option is either Selected “ON” or Not Selected “OFF.” Replacement of meter case will be needed for coin slide mounting.
d. 00	Not Selected ‘OFF’.
d. CS	Selected ‘ON’. <b>NOTE:</b> This option needs to be set to ‘00’ unless the meter case has been changed to accept a coin slide device. Press the COLORS/DELICATES button 3 consecutive times for this selection. When coin slide mode is selected, set ‘b.’ equal to value of vend price in nickels. Set ‘6 XX’ (REGULAR CYCLE PRICE) and ‘3.XX’ (SPECIAL CYCLE PRICE) to number of slide operations. <b>NOTE:</b> If the installer sets up ‘CS’ on a coin drop model, the dryer will not register coins inserted. <ul style="list-style-type: none"> <li>Press the PERM PRESS button once to advance to next code.</li> </ul>
E. 00	<b>ADD COINS OPTION</b> This option is either Selected ‘ON’ or Not Selected ‘OFF’. This option causes the customer display to show the number of coins (coin 1) to enter, rather than the dollars-and-cents amount.
E. 00	Not Selected ‘OFF’.
E. AC	Selected ‘ON’. Press the COLORS/DELICATES button 3 consecutive times for this selection. 9160 MODELS ONLY: In enhanced debit mode, this option is not selectable. <ul style="list-style-type: none"> <li>Press the PERM PRESS button once to advance to next code.</li> </ul>
J. Cd	<b>PAYMENT MODE (COIN/DEBIT OPTION)</b>
J. Cd	Both coin and debit selected. Press the COLORS/DELICATES button 3 consecutive times to change this selection.
J. C_	Coins selected, debit disabled. Press the COLORS/DELICATES button 3 consecutive times to change this selection.
J. _d	Debit Card selected, coin disabled (default for 9160 models). This selection must be used for free vend. Press the COLORS/DELICATES button 3 consecutive times to change this selection.
J. Ed	Enhanced Debit is self-selected when a Generation 2 card reader is installed in the dryer. The “Ed” option cannot be manually selected or deselected. <ul style="list-style-type: none"> <li>Press the PERM PRESS button once to advance to next code.</li> </ul>

Code	Explanation
L. 00	<b>PRICE SUPPRESSION OPTION</b> This option is either Selected ‘ON’ or Not Selected ‘OFF’. This option causes the customer display to show ‘AVAILABLE’ or ‘ADD’ rather than the amount of money to add. (Used mainly in debit installations.)
L. 00	Not Selected ‘OFF’.
L. PS	Selected ‘ON’. Press the COLORS/DELICATES button once for this selection. <ul style="list-style-type: none"> <li>Press the PERM PRESS button once to advance to next code.</li> </ul>
n. CE	<b>CLEAR ESCROW OPTION</b> This option is either Selected “ON” or Not Selected “OFF.” When selected, money held in escrow for 30 minutes without further escrow or cycle activity will be cleared.
n. 00	Not Selected “OFF.”
n. CE	Selected “ON.” <ul style="list-style-type: none"> <li>Press the COLORS/DELICATES button once to change this selection.</li> <li>Press the PERM PRESS button once to advance to next code.</li> </ul>
U. 00	<b>PENNY INCREMENT OFFSET</b>
U. 00	This represents the penny increment price offset used in Generation 2 (Enhanced Debit) 9160 models. Choose from 0–4 pennies by pressing the COTTON/WHITES button. <ul style="list-style-type: none"> <li>Press the PERM PRESS button once to advance to next code.</li> </ul>

**If cycle counter (9 0C) is selected, the following is true:**

1 00	Cycles in HUNDREDS	1 <u>02</u> = 200
2 00	Cycles in ONES	2 <u>25</u> = 25
		TOTAL CYCLES = 225

This is “VIEW ONLY” and cannot be cleared.

- Press the PERM PRESS button once to advance to next code.

**If money counter (1.0C or 1.C0) is selected, the following is true:**

3 00	Dollars in HUNDREDS	3 <u>01</u> = \$100.00
4 00	Dollars in ONES	4 <u>68</u> = \$ 68.00
5 00	Number of CENTS	5 <u>75</u> = \$ 00.75
		TOTAL = \$168.75

END of SET-UP PROCEDURES

**TO EXIT FROM SET-UP MODE**

- Close the service access door.
- Disconnect dryer from power before reinstalling the AA1 connector, if it was removed.
- Remove the manual set-up card.
- Wait two minutes without activating any dryer inputs.
- Disconnect and then reconnect power.

# ELECTRONIC CONTROL SETUP INSTRUCTIONS

## Diagnostic Codes

If the set-up mode is entered and one of the following has previously occurred, the appropriate diagnostic code will be in the display.

Dryer Display	Explanation
d 5	Blocked coin 1 or coin drop UI control circuit failure (coin recognition and customer display disabled while blockage persists).
d 9	Voltage detected below 90 VAC for 8 seconds.
d 13	Blocked coin 2 or coin drop UI control circuit failure (coin recognition and customer display disabled while blockage persists).
d 16	Not receiving communications from installed debit card reader in Enhanced (Generation 2) Debit mode.
F 01	Dryer motor control circuit error (cycles and price display disabled until diagnostic code is manually cleared). The control doesn't know if the motor relay is bad (stuck on), the motor relay drive circuit is bad (shorted), causing the motor relay to stay on, or the motor relay feedback circuit is bad.
F 22	Exhaust thermistor open, temperature drops below 18°F (>50 kΩ) for 1 minute in Run mode, or immediately in Factory Diagnostic Mode.
F 23	Exhaust thermistor shorted, temperature above 250°F (<500Ω) for 1 minute in Run mode, or immediately in Factory Diagnostic Mode.
F 70	UI is not receiving communications from CCU (cycles and price display disabled while error persists or is manually cleared).
F 71	CCU is not receiving communications from UI (cycles and price display disabled while error persists or is manually cleared).
F 73	UI Microprocessor is not able to read or verify EEPROM (cycles and price display disabled until diagnostic code is manually cleared).
F 74	UI EEPROM memory is a CRC failure (cycles and price display disabled until diagnostic code is manually cleared).

## Dryer Diagnostic Mode

This mode is entered by pressing COLORS/DELICATES for one second while in either of the set-up codes 6.xx or 7.xx or with a diagnostic code present. Diagnostic codes are cleared on entry and all display segments should flash. If a diagnostic code persists, it must be corrected before the diagnostic cycle can be entered.

### All Models:

With all segments flashing, the diagnostic cycle is started by pressing the PERM PRESS button. The cycle consists of 7 minutes of heat and 1 minute of cooldown.

The COTTON/WHITES button will increment the diagnostic cycle minutes up to 99, then roll over to 2 minutes. The COLORS/DELICATES button will cancel this cycle and exit the diagnostic mode.

### Dryer Help Mode

Dryer help mode is entered by pressing the COTTON/WHITES button while in special pricing option 2.XX. In help mode, the software revision is displayed. The help mode is advanced by pressing the PERM PRESS button. See Help Mode Submenu below for the order in which items are displayed. Press the COTTON/WHITES button at any time to exit help mode.

### Help Codes

Help Code	Description
71	Generation 2 debit card cycle polling message out of sequence.
74	Generation 2 debit card remaining balance message out of sequence.
75	Generation 2 debit card new card balance message out of sequence.
88	Invalid messaging state found in data acquisition communications comm_suprv () routine.



# ELECTRONIC CONTROL SETUP INSTRUCTIONS

## Help Mode Submenu

Step	Display Indication	Explanation
1	1h.XX	Help Code 1, where XX is the help code number. *
2	2h.XX	Help Code 2, where XX is the help code number. *
3	3h.XX	Help Code 3, where XX is the help code number. *
4	1.X##	Error history code 1, where X is the F or d code, and ## is the code number. **
5	2.X##	Error history code 2, where X is the F or d code, and ## is the code number. **
6	3.X##	Error history code 3, where X is the F or d code, and ## is the code number. **
7	4.X##	Error history code 4, where X is the F or d code, and ## is the code number. **
8	SC.XX	CCU software revision, where XX is the software revision number.
9	SU.XX	UI software revision, where XX is the software number.
10	EU.XX	UI EEPROM revision, where XX is the EEPROM number.

\* To erase the 3 help codes, press COLORS/DELICATES button.

\*\* The Errors displayed in this section are the history errors that have occurred in the dryer (not necessarily an error that is in progress). The current error is displayed in the MANUAL KEY FUNCTION IN DIAGNOSTIC SUB-MODE.

In help mode, other display symbols and elements are mapped to reflect the state of various inputs and outputs as follows:

### All Dryers

\*.....low voltage present (below about 90 VAC)  
 °(circle above digit) ..... door closed  
 OR..... motor sensed running  
 AIR..... heater/gas valve relay on  
 FLUFF.....motor relay on

# WHIRLPOOL® COMMERCIAL LAUNDRY LIMITED WARRANTY

## IF YOU NEED SERVICE:

Contact your authorized Whirlpool® Commercial Laundry distributor. To locate your authorized Whirlpool® Commercial Laundry distributor, call: **1-800-662-3587, or for web inquiries, visit [www.WhirlpoolCommercialLaundry.com](http://www.WhirlpoolCommercialLaundry.com).**

For written correspondence:

**Whirlpool® Commercial Laundry Service Department  
2000 N M 63  
Benton Harbor, Michigan 49022-2632 USA**

## 90 DAY LIMITED WARRANTY

### WHAT IS COVERED

#### 90 DAY LIMITED WARRANTY (PARTS AND LABOR)

For 90 days from the original date of purchase, when this commercial appliance is installed, maintained, and operated according to the instructions attached to or furnished with the product, Whirlpool Corporation (hereafter "Whirlpool") will pay for factory specified replacement parts and repair labor to correct defects in materials or workmanship that existed when this commercial appliance was purchased.

#### TWO YEAR LIMITED WARRANTY (PARTS ONLY)

For the first two years from the original date of purchase, when this commercial appliance is installed, maintained, and operated according to the instructions attached to or furnished with the product, Whirlpool will pay for factory specified replacement parts to correct defects in materials or workmanship that existed when this commercial appliance was purchased.

**YOUR SOLE AND EXCLUSIVE REMEDY UNDER THIS LIMITED WARRANTY SHALL BE PRODUCT REPAIR AS PROVIDED HEREIN.** Whirlpool recommends that you use an "in network" service provider to diagnose and repair your Commercial Laundry product. Whirlpool will not be responsible under this warranty to provide additional replacement parts as a result of incorrect diagnosis or repair by an "out of network" service company. This limited warranty is valid in the United States or Canada and applies only when the commercial appliance is used in the country in which it was purchased. This limited warranty is effective from the date of the original consumer purchase. Proof of original purchase date is required to obtain service under this limited warranty.

### WHAT IS NOT COVERED

1. All other costs including labor, transportation, shipping, or custom duties for covered parts.
2. Factory specified replacement parts if this commercial appliance is used for other than normal, commercial use or when it is used in a manner that is inconsistent to published user or operator instructions and/or installation instructions.
3. Service calls to correct the installation of your commercial appliance, to instruct you on how to use your commercial appliance, to replace or repair house fuses, or to correct external wiring or plumbing.
4. Service calls to repair or replace appliance light bulbs, air filters, or water filters. Consumable parts are excluded from warranty coverage.
5. Damage resulting from improper handling of product during delivery, theft, accident, alteration, misuse, abuse, fire, flood, acts of God, improper installation, installation not in accordance with local electrical or plumbing codes, or use of products not approved by Whirlpool.
6. Pick up and delivery. This commercial appliance is designed to be repaired on location.
7. Repairs to parts or systems resulting from unauthorized modifications made to the commercial appliance.
8. The removal and reinstallation of your commercial appliance if it is installed in an inaccessible location or is not installed in accordance with published installation instructions.
9. Damage resulting from exposure to chemicals.
10. Changes to the building, room, or location needed in order to make the commercial appliance operate correctly.
11. Factory specified replacement parts on commercial appliances with original model/serial numbers that have been removed, altered, or cannot be easily determined.
12. Discoloration, rust, or oxidation of stainless steel surfaces.
13. Factory specified replacement parts as a result of incorrect diagnosis or repair by an "out of network" service company.

**The cost of repair or replacement under these excluded circumstances shall be borne by the customer.**

## DISCLAIMER OF IMPLIED WARRANTIES

IMPLIED WARRANTIES, INCLUDING ANY IMPLIED WARRANTY OF MERCHANTABILITY OR IMPLIED WARRANTY OF FITNESS FOR A PARTICULAR PURPOSE, ARE LIMITED TO TWO YEARS OR THE SHORTEST PERIOD ALLOWED BY LAW. Some states and provinces do not allow limitations on the duration of implied warranties of merchantability or fitness, so this limitation may not apply to you. This warranty gives you specific legal rights, and you also may have other rights that vary from state to state or province to province.

## DISCLAIMER OF REPRESENTATIONS OUTSIDE OF WARRANTY

Whirlpool makes no representations about the quality, durability, or need for service or repair of this major appliance other than the representations contained in this Warranty. If you want a longer or more comprehensive warranty than the limited warranty that comes with this major appliance, you should ask Whirlpool or your retailer about buying an extended warranty.

## LIMITATION OF REMEDIES; EXCLUSION OF INCIDENTAL AND CONSEQUENTIAL DAMAGES

**YOUR SOLE AND EXCLUSIVE REMEDY UNDER THIS LIMITED WARRANTY SHALL BE PRODUCT REPAIR AS PROVIDED HEREIN. WHIRLPOOL SHALL NOT BE LIABLE FOR INCIDENTAL OR CONSEQUENTIAL DAMAGES.** Some states and provinces do not allow the exclusion or limitation of incidental or consequential damages, so these limitations and exclusions may not apply to you. This warranty gives you specific legal rights, and you also may have other rights that vary from state to state or province to province.

08/16

