

INSTALLATION INSTRUCTIONS 27" (68.6 CM) AND 30" (76.2 CM) ELECTRIC BUILT-IN CONVECTION MICROWAVE OVEN

INSTRUCTIONS D'INSTALLATION FOUR À MICRO-ONDES ENCASTRÉ ÉLECTRIQUE À CONVECTION DE 27" (68,6 CM) ET 30" (76,2 CM)

Table of Contents/Table des matières

BUILT-IN MICROWAVE OVEN SAFETY	1	SÉCURITÉ DU FOUR À MICRO-ONDES ENCASTRÉ	7
INSTALLATION REQUIREMENTS	2	EXIGENCES D'INSTALLATION	7
Tools and Parts	2	Outils et pièces	7
Location Requirements	2	Exigences d'emplacement	7
Electrical Requirements.....	3	Spécifications électriques	9
INSTALLATION INSTRUCTIONS	4	INSTRUCTIONS D'INSTALLATION	10
Spacer Kit Installation	4	Installation de la trousse d'entretoise.....	10
Prepare Built-In Microwave Oven.....	4	Préparation du four à micro-ondes encastré	10
Make Electrical Connection.....	5	Raccordement électrique	10
Install Microwave Oven	5	Installation du four à micro-ondes.....	11
Complete Installation	6	Achever l'installation	12

BUILT-IN MICROWAVE OVEN SAFETY

Your safety and the safety of others are very important.

We have provided many important safety messages in this manual and on your appliance. Always read and obey all safety messages.



This is the safety alert symbol.

This symbol alerts you to potential hazards that can kill or hurt you and others.

All safety messages will follow the safety alert symbol and either the word "DANGER" or "WARNING."

These words mean:

⚠ DANGER

You can be killed or seriously injured if you don't immediately follow instructions.

⚠ WARNING

You can be killed or seriously injured if you don't follow instructions.

All safety messages will tell you what the potential hazard is, tell you how to reduce the chance of injury, and tell you what can happen if the instructions are not followed.

INSTALLATION REQUIREMENTS

Tools and Parts

Gather the required tools and parts before starting installation. Read and follow the instructions provided with any tools listed here.

Tools Needed

- Phillips screwdriver
- Flat-blade screwdriver
- Measuring tape
- Level
- Drill (for wall cabinet installations)
- 1/8" (3 mm) drill bit (for wall cabinet installations)
- 1" (2.5 cm) drill bit (for wall cabinet installations)

Parts Needed

- A UL listed or CSA approved conduit connector
- UL listed wire connectors

Parts Needed - Flush Installation

- W10752697 Stainless steel flush installation kit for 30" (76.2 cm) models
- W10752698 Stainless steel flush installation kit for 27" (68.6 cm) models
- W10839402 Limited edition black flush installation kit for 30" (76.2 cm) models

To order, see the "Assistance or Service" section of the Use and Care Guide.

Parts Supplied

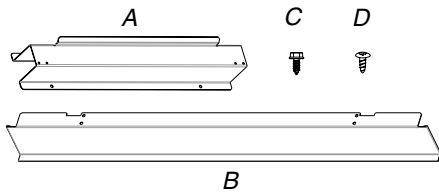

- A. Spacer bars (2)
- B. Bottom vent (1)
- C. 3/8" hex-head washer screws (4)
- D. 3/4" pan-head screws (4)

Check local codes. Check existing electrical supply. See "Electrical Requirements."

It is recommended that all electrical connections be made by a licensed, qualified electrical installer.

Location Requirements

IMPORTANT: Observe all governing codes and ordinances.

- Cabinet opening dimensions that are shown must be used. Given dimensions provide minimum clearance with microwave oven.
- Recessed installation area must provide complete enclosure around the recessed portion of the microwave oven.
- Grounded electrical supply is required. See "Electrical Requirements" section.
- Electrical supply junction box should be located 3" (7.6 cm) maximum below the support surface when the microwave oven is installed in a wall cabinet. A 1" (2.5 cm) minimum diameter hole should have been drilled in the left rear corner of the support surface to pass the appliance cable through to the junction box.

- For installation above single built-in oven, the junction box must be located inside upper cabinet.
- If you are installing the junction box on rear wall behind the microwave oven, the junction box must be recessed and located in the upper or lower right or left corner of the cabinet; otherwise, the microwave oven will not fit into the cabinet opening.
- Microwave oven support surface must be solid, level and flush with bottom of cabinet cutout. Floor must be able to support a weight of 90 lbs (41.0 kg).

IMPORTANT: To avoid damage to your cabinets, check with your builder or cabinet supplier to make sure that the materials used will not discolor, delaminate or sustain other damage. This oven has been designed in accordance with the requirements of UL and CSA International and complies with the maximum allowable wood cabinet temperatures of 194°F (90°C).

Product Dimensions

27" (68.6 cm) and 30" (76.2 cm) Microwave Ovens

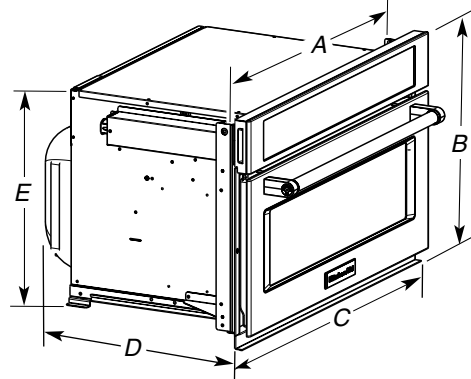

27" (68.6 cm) Models

- A. 25 5/8" (64.5 cm)
- B. 18 5/8" (47.3 cm) overall height
- C. 26 3/4" (68.0 cm) overall width
- D. 21 1/2" (54.6 cm)
- E. 17 3/8" (44.1 cm)

30" (76.2 cm) Models

- A. 28 5/8" (72.1 cm)
- B. 18 5/8" (47.3 cm) overall height
- C. 29 3/4" (75.6 cm) overall width
- D. 21 1/2" (54.6 cm)
- E. 17 3/8" (44.1 cm)

27" (68.6 cm) and 30" (76.2 cm) Microwave Oven Spacer Kit

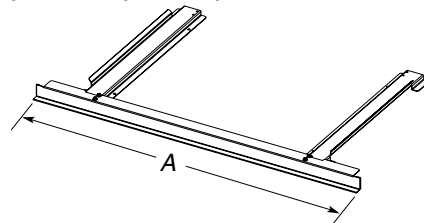

27" (68.6 cm) Models

- A. 26 3/4" (67.9 cm) overall width

30" (76.2 cm) Models

- A. 29 3/4" (75.6 cm) overall width

NOTE: The microwave oven spacer kit will allow the microwave oven to be installed in a 17 5/8" to 17 3/4" (44.1 to 45.1 cm) maximum cutout height.

A microwave oven spacer kit is available from your dealer that will allow the microwave oven to be installed in a 19 1/4" to 19 11/16" (48.9 - 50.0 cm) maximum cutout height. Match the oven size to the following kits:

- 27" (68.6 cm) Stainless Steel - Spacer Kit W10469901
- 30" (76.2 cm) Stainless Steel - Spacer Kit W10469903
- 30" (76.2 cm) Limited Edition Black - Spacer Kit W10842584

To order, see the "Assistance or Service" section of the Use and Care Guide.

Cabinet Dimensions

27" (68.6 cm) and 30" (76.2 cm) Microwave Ovens

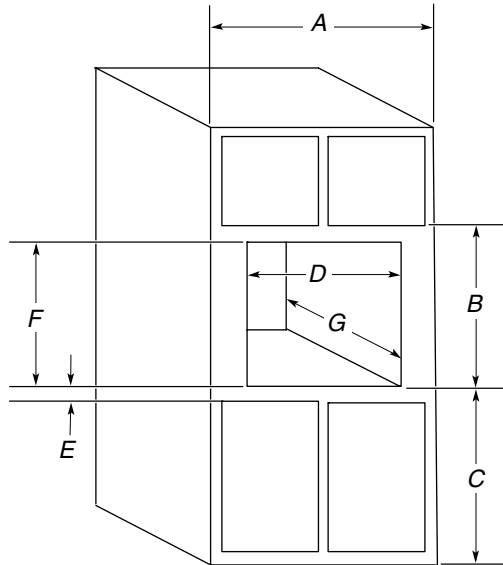

27" (68.6 cm) Models

- A. 27" (68.6 cm) min. cabinet width
- B. 18⁵/₈" (47.3 cm) from bottom of cutout to bottom of upper cabinet door
- C. 40" (101.6 cm) bottom of cutout to floor (recommended)
- D. 25¹/₂" (64.8 cm) cutout width
- E. 1¹/₂" (3.8 cm) min. bottom of cutout to top of cabinet door
- F. 17⁷/₈" (44.7 cm) recommended cutout height (will fit cutout height from 17³/₈" [44.1 cm] to 17³/₄" [45.1 cm])
- G. 21⁷/₈" (55.5 cm) min. cutout depth

30" (76.2 cm) Models

- A. 30" (76.2 cm) min. cabinet width
- B. 18⁵/₈" (47.3 cm) from bottom of cutout to bottom of upper cabinet door
- C. 40" (101.6 cm) bottom of cutout to floor (recommended)
- D. 28¹/₂" (72.4 cm) cutout width
- E. 1¹/₂" (3.8 cm) min. bottom of cutout to top of cabinet door
- F. 17⁷/₈" (44.7 cm) recommended cutout height (will fit cutout height from 17³/₈" [44.1 cm] to 17³/₄" [45.1 cm])
- G. 21⁷/₈" (55.5 cm) min. cutout depth

Minimum Installation Clearances

For proper installation, the following minimum clearances must exist above and below the cabinet opening.

Installation Above Single Built-In Oven

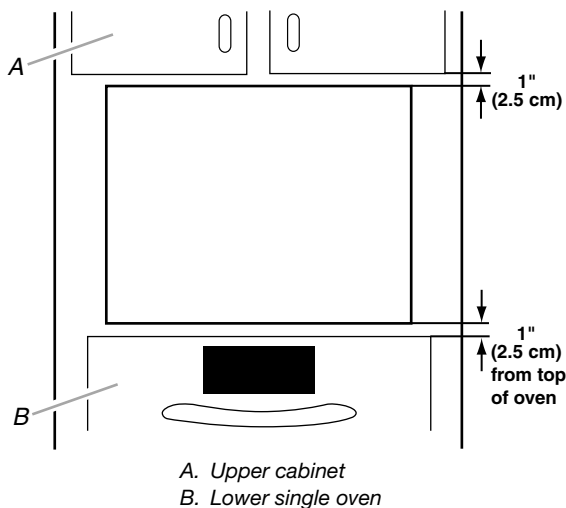

Approved models: KMBP100E and KMBP107E

Electrical Requirements

GROUNDING INSTRUCTIONS

For a permanently connected microwave oven:

The microwave oven must be connected to a grounded, metallic, permanent wiring system, or an equipment grounding conductor should be run with the circuit conductors and connected to the equipment grounding terminal or lead on the microwave oven.

SAVE THESE INSTRUCTIONS

If codes permit and a separate ground wire is used, it is recommended that a qualified electrical installer determine that the ground path and wire gauge are in accordance with local codes.

Check with a qualified electrical installer if you are not sure the microwave oven is properly grounded.

This microwave oven must be connected to a grounded metal, permanent wiring system.

Be sure that the electrical connection and wire size are adequate and in conformance with the National Electrical Code, ANSI/NFPA 70-latest edition or CSA Standards C22.1-94, Canadian Electrical Code, Part 1 and C22.2 No. O-M91-latest edition, and all local codes and ordinances.

A copy of the above code standards can be obtained from:

National Fire Protection Association
1 Batterymarch Park
Quincy, MA 02169-7471

CSA International
8501 East Pleasant Valley Road
Cleveland, OH 44131-5575

Electrical Connection

To properly install your microwave oven, you must determine the type of electrical connection you will be using and follow the instructions provided for it here.

- Microwave oven must be connected to the proper electrical voltage and frequency as specified on the model/serial/rating plate. The model/serial/rating plate is located underneath the control panel, along the oven vent.

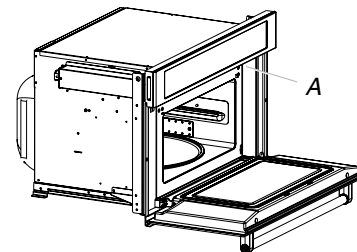

A. Model/serial/rating plate

- The microwave oven rated 240 volt, 20-amp, has 4 wires (L1, L2, N and G) in the flex conduit and should be connected to a 20-amp maximum rated circuit, overcurrent protected on both the L1 and L2 circuits.
- A time-delay fuse or circuit breaker is recommended.
- Flexible cable from the microwave oven should be connected directly to the junction box.
- Do not cut the conduit. The length of conduit provided is for serviceability of the microwave oven.

- A UL listed or CSA approved conduit connector must be provided.
- If the house has aluminum wiring follow the procedure below:

Connect the aluminum wiring using special connectors and/or tools designed and UL listed for joining copper to aluminum.

Follow the electrical connector manufacturer's recommended procedure. Aluminum/copper connection must conform with local codes and industry accepted wiring practices.

For power requirements, refer to the following table:

Voltage	Microwave With Convection Oven
240 VAC	19.9 A/3250 W
208 VAC	19.9 A/3250 W

INSTALLATION INSTRUCTIONS

Spacer Kit Installation

NOTES:

- The microwave oven spacer kit allows the microwave oven to be installed in an 17⁷/₁₆" to 17⁷/₈" (44.1 cm to 45.3 cm) maximum cutout height.
- If your cabinet cutout height is more than 17⁷/₁₆" (44.1 cm), you must install the spacer kit. Proceed to "Assemble Spacer Kit."
- If your cabinet cutout height is less than 17⁷/₁₆" (44.1 cm), you do not have to install the spacer kit. Proceed to "Prepare Built-In Microwave Oven."

Assemble Spacer Kit

1. Attach the bottom vent to spacer bars using four 3/8" hex-head washer screws.

NOTE: Spacer bar flanges should be facing out.

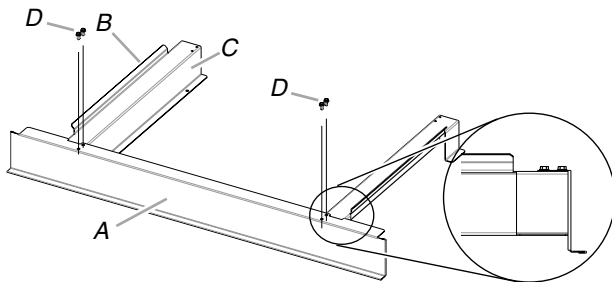

- A. Bottom vent
- B. Spacer bar flange
- C. Spacer bars
- D. 3/8" hex-head washer screws

Install Spacer Kit

1. Center assembled microwave oven spacer kit against lower front edge of the cabinet cutout.
2. Using an 1/8" (0.32 cm) drill bit, drill through the mounting holes in the spacer bars to create pilot holes.

3. Attach the assembled spacer kit to the cabinet using four 3/4" flat-head screws. Do not overtighten screws.

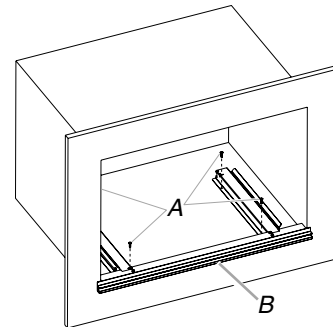

- A. 3/4" pan-head screws
- B. Spacer kit assembly

Prepare Built-In Microwave Oven

1. Locate existing wiring to avoid drilling into or severing wiring during installation.

⚠ WARNING

Excessive Weight Hazard

Use two or more people to move and install microwave oven.

Failure to do so can result in back or other injury.

2. To avoid floor damage, set the microwave oven onto cardboard prior to installation. Do not use handle or any portion of the front frame for lifting.
3. Remove the shipping materials and tape from the microwave oven.
4. Remove and set aside racks and other items from inside the microwave oven.
5. Remove the hardware package from inside the bag containing literature.
6. Move the microwave oven and cardboard close to the microwave oven's final location.

Make Electrical Connection

⚠ WARNING



Electrical Shock Hazard

Disconnect power before servicing.

Use 12 gauge copper wire.

Electrically ground oven.

Failure to follow these instructions can result in death, fire, or electrical shock.

This microwave oven is manufactured with a neutral (white) power supply wire and a cabinet-connected green (or bare) ground wire.

1. Disconnect power.
2. Feed the flexible cable conduit from the microwave oven through the opening in the cabinet.
3. Remove junction box cover if it is present.
4. Install a UL listed or CSA approved conduit connector to the junction box.

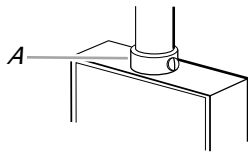

A. UL listed or CSA approved conduit connector

5. Route the flexible cable conduit from the microwave oven to the junction box through a UL listed or CSA approved conduit connector.
6. Tighten screws on conduit connector.
7. Complete electrical connection.

3-Wire Cable with Ground from Home Power Supply to Microwave Oven Cable with 4-Wires

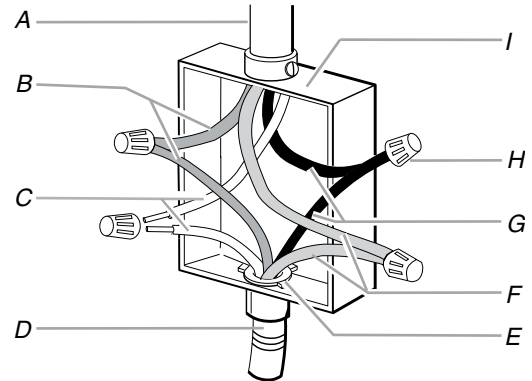

- | | |
|--|-----------------------------|
| A. Cable from home power supply | F. Red wires |
| B. Green (or bare) wires | G. Black wires |
| C. White wires | H. UL listed wire connector |
| D. 4-wire cable from microwave oven | I. Junction box |
| E. UL listed or CSA approved conduit connector | |

1. Connect the 2 black wires (G) together using a UL listed wire connector.
2. Connect the 2 white wires (C) using a UL listed wire connector.
3. Connect the 2 red wires (F) together using a UL listed wire connector.
4. Connect the 2 green (or bare) wires (B) together using a UL listed wire connector.
5. Install junction box cover.

Install Microwave Oven

1. Using 2 or more people, lift the microwave oven partially into the cabinet cutout. If a spacer kit has been installed, lift the microwave oven over it and position the microwave between the guide strips.

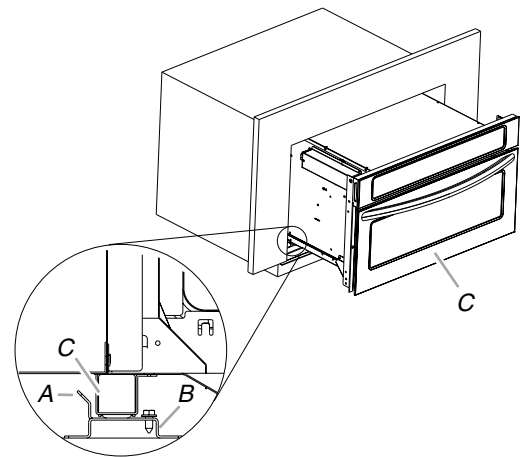

- | |
|----------------------|
| A. Spacer bar flange |
| B. Spacer bar |
| C. Microwave oven |

2. Push against the front frame of the microwave oven to insert oven into cabinet. Push microwave oven completely into cabinet and center in cabinet cutout.

NOTE: Open microwave oven door and push against seal area of microwave oven front frame when pushing microwave oven into cabinet. Do not push against outside edges.

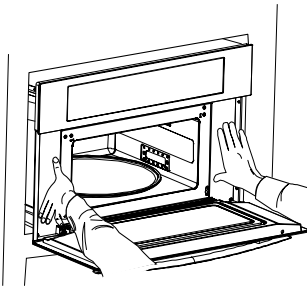

3. Using an 1/8" (0.32 cm) drill bit, predrill pilot holes through the mounting rails on each side of the microwave oven.
4. Securely fasten microwave oven to cabinet using two 3/4" flathead screws provided. Insert the screws through holes in mounting rails. Do not overtighten screws.

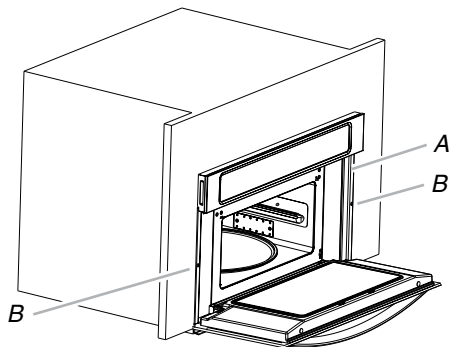

A. Mounting rail
B. Flat-head screws

5. Replace convection grid, turntable and support hub.
6. Reconnect power.
7. Display panel will light briefly, and the clock should appear in the display.
8. If display panel does not light, please reference the "Assistance or Service" section of the Use and Care Guide or contact the dealer from whom you purchased your microwave oven.

Complete Installation

1. Check that all parts are now installed. If there is an extra part, go back through the steps to see which step was skipped.
2. Check that you have all of your tools.
3. Dispose of/recycle all packaging materials.
4. For microwave oven use and cleaning, read the Use and Care Guide.

Check Operation of Microwave Oven

1. Fill a microwave-safe container with 1 cup (250 mL) of water and place container on the turntable inside the microwave oven. Close door firmly.
2. Touch COOK.
3. Set power level, temperature and cook time to "2:00" minutes.
4. Touch START.

If microwave does not operate, check the following:

- Household fuse is intact and tight; or circuit breaker has not tripped.
- Electrical supply is connected;
- See "Troubleshooting" section in the Use and Care Guide.

When the display reads "1:00" minute, open the microwave oven door. The microwave oven should stop cooking. Close door firmly. The interior microwave oven light should turn off.

5. Touch START to resume a preset cycle. The microwave oven should begin cooking, and the microwave oven interior light should be on.
Let microwave oven complete cooking time. Tones will sound at the end of the cooking time, and the microwave oven will shut off.
6. Open microwave oven door and slowly remove container. Water in container should be hot.
7. To set the clock and other microwave oven functions, refer to the Use and Care Guide.

If you need Assistance or Service:

Please reference the "Assistance or Service" section of the Use and Care Guide or contact the dealer from whom you purchased your built-in microwave oven.