

INSTALLATION INSTRUCTIONS
30" (76.2 CM), 36" (91.4 CM) AND 48" (121.9 CM)
COMMERCIAL STYLE DUAL FUEL
CONVECTION RANGE

for residential use only

INSTRUCTIONS D'INSTALLATION
CUISINIÈRE À CONVECTION - STYLE COMMERCIAL À
BI-COMBUSTIBLE
DE 30" (76,2 CM), 36" (91,4 CM) ET 48" (121,9 CM)
pour utilisation résidentielle uniquement

Table of Contents/Table des matières..... 2

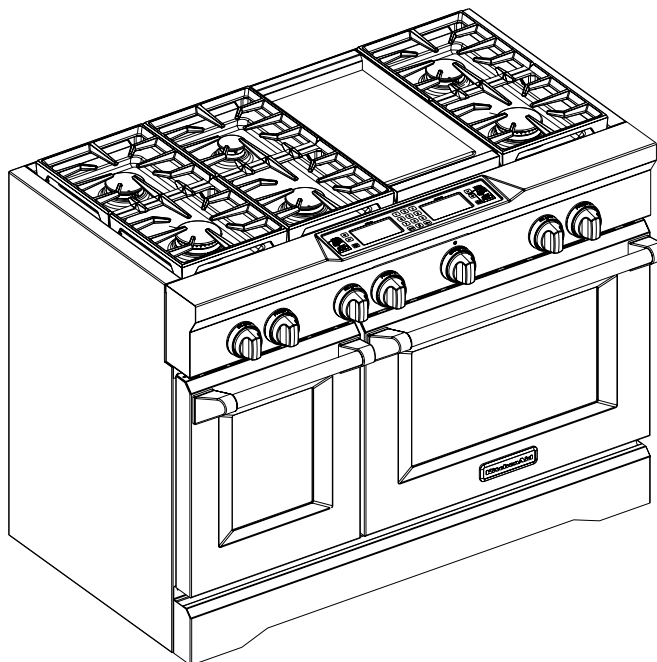

IMPORTANT:

Save for local electrical inspector's use.

Installer: Leave installation instructions with the homeowner.

Homeowner: Keep installation instructions for future reference.

IMPORTANT :

À conserver pour consultation par l'inspecteur local des installations électriques.

Installateur : Remettre les instructions d'installation au propriétaire.

Propriétaire : Conserver les instructions d'installation pour référence ultérieure.

W10526083C

TABLE OF CONTENTS

RANGE SAFETY	3
INSTALLATION REQUIREMENTS	4
Tools and Parts	4
Location Requirements	5
Water Filtration System Location Requirements	7
Water Supply Requirements	8
Electrical Requirements - U.S.A. Only	8
Electrical Requirements - Canada Only	9
Gas Supply Requirements	9
INSTALLATION INSTRUCTIONS	11
Unpack Range	11
Install Optional Backguard	11
Install Anti-Tip Bracket	11
Electrical Connection - U.S.A. Only	13
Install Water Filtration System	14
Make Gas Connection	16
Verify Anti-Tip Bracket Location	16
Level Range	17
Install Grill Grease Trays	17
Install Griddle	18
Electronic Ignition System	18
Reinstall Kick Plate	20
Complete Installation	20
GAS CONVERSIONS	21
LP Gas Conversion	21
Natural Gas Conversion	23
Strip Circuits	26
Wiring Diagrams	27

TABLE DES MATIÈRES

SÉCURITÉ DE LA CUISINIÈRE	33
EXIGENCES D'INSTALLATION	34
Outillage et pièces	34
Exigences d'emplacement	35
Exigences d'emplacement du système de filtration de l'eau	37
Spécifications de l'alimentation en eau	38
Spécifications de l'installation électrique	38
Spécifications de l'alimentation en gaz	38
INSTRUCTIONS D'INSTALLATION	40
Déballage de la cuisinière	40
Installation du dossieret facultatif	40
Installation de la bride antibasculément	40
Installation du système de filtration de l'eau	41
Raccordement au gaz	43
Vérification de l'emplacement de la bride antibasculément	43
Réglage de l'aplomb de la cuisinière	43
Installation des plateaux à graisse du gril	44
Installation de la plaque à frire	45
Système d'allumage électronique	45
Réinstallation du garde-pieds	47
Achever l'installation	47
CONVERSIONS POUR CHANGEMENT DE GAZ	48
Conversion pour l'alimentation au propane	48
Conversion pour l'alimentation au gaz naturel	50
Schémas des circuits du four	53
Schémas de câblage	54

RANGE SAFETY

Your safety and the safety of others are very important.

We have provided many important safety messages in this manual and on your appliance. Always read and obey all safety messages.



This is the safety alert symbol.

This symbol alerts you to potential hazards that can kill or hurt you and others.

All safety messages will follow the safety alert symbol and either the word “DANGER” or “WARNING.” These words mean:

⚠ DANGER

You can be killed or seriously injured if you don't immediately follow instructions.

⚠ WARNING

You can be killed or seriously injured if you don't follow instructions.

All safety messages will tell you what the potential hazard is, tell you how to reduce the chance of injury, and tell you what can happen if the instructions are not followed.

WARNING: If the information in this manual is not followed exactly, a fire or explosion may result causing property damage, personal injury or death.

- Do not store or use gasoline or other flammable vapors and liquids in the vicinity of this or any other appliance.
- WHAT TO DO IF YOU SMELL GAS:
 - Do not try to light any appliance.
 - Do not touch any electrical switch.
 - Do not use any phone in your building.
 - Immediately call your gas supplier from a neighbor's phone. Follow the gas supplier's instructions.
 - If you cannot reach your gas supplier, call the fire department.
- Installation and service must be performed by a qualified installer, service agency or the gas supplier.

WARNING: Gas leaks cannot always be detected by smell.

Gas suppliers recommend that you use a gas detector approved by UL or CSA.

For more information, contact your gas supplier.

If a gas leak is detected, follow the “What to do if you smell gas” instructions.

IMPORTANT: Do not install a ventilation system that blows air downward toward this gas cooking appliance. This type of ventilation system may cause ignition and combustion problems with this gas cooking appliance resulting in personal injury or unintended operation.

In the State of Massachusetts, the following installation instructions apply:

- Installations and repairs must be performed by a qualified or licensed contractor, plumber, or gasfitter qualified or licensed by the State of Massachusetts.
- If using a ball valve, it shall be a T-handle type.
- A flexible gas connector, when used, must not exceed 3 feet.



⚠ WARNING

Tip Over Hazard

A child or adult can tip the range and be killed.

Install anti-tip bracket to floor or wall per installation instructions.

Slide range back so rear range foot is engaged in the slot of the anti-tip bracket.

Re-engage anti-tip bracket if range is moved.

Do not operate range without anti-tip bracket installed and engaged.

Failure to follow these instructions can result in death or serious burns to children and adults.

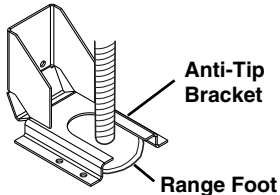

To verify the anti-tip bracket is installed and engaged:

- Slide range forward.
- Look for the anti-tip bracket securely attached to floor or wall.
- Slide range back so rear range foot is under anti-tip bracket.
- See installation instructions for details.

INSTALLATION REQUIREMENTS

Tools and Parts

Gather the required tools and parts before starting installation. Read and follow the instructions provided with any tools listed here.

Tools needed

- Tape measure
- #2 Phillips screwdriver
- 1/8" x 4 1/4" flat-blade screwdriver
- Level
- Drill
- Wrench or pliers
- Pipe wrench
- Adjustable wrench or 5/8" wrench
- 3/8" drive ratchet
- 1/8" drill bit
- 1 5/16" combination wrench
- 1/4", 3/8", 5/16" nut drivers
- 3/16" carbide tip masonry bit
- Marker or pencil
- Pipe-joint compound resistant to LP gas
- Noncorrosive leak-detection solution
- Tubing cutter

For LP/Natural Gas Conversions

- Adjustable wrench
- 1/2" deep-well socket
- 7 mm nut driver
- Masking tape

Parts supplied

Check that all parts are included.

- Anti-tip bracket kit

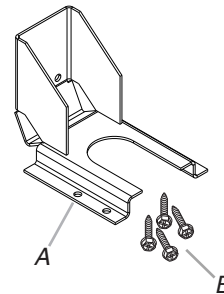

A. Anti-tip bracket
B. #8-18 x 1" Phillips head screws (4)

NOTE: Anti-tip bracket must be securely mounted to subfloor. Thickness of flooring may require longer screws to anchor bracket to subfloor. Longer screws are available from your local hardware store. See "Install Anti-Tip Bracket" section.

- Gas pressure regulator
- Burner grates
- Burner bases and caps
- Grill grate (on grill models)
- Wave tray (on grill models)
- Flame spreader (on grill models)

- Burner assembly (on grill models)
- Grease trays (2) (on grill models)
- Griddle drip tray (on griddle models)
- Grill drip tray (on grill models)
- Island trim
- LP orifice package (W10393255)
- Conversion label (W10393342)

NOTE: The cooktop is manufactured for use with Natural gas. To convert to LP gas, see the “LP Gas Conversion” section.

Additional Parts Supplied on Steam-Assist Models

- Model W10049700 water filter kit
- ¼" to ¼" water supply union

Parts needed

- Power supply cord kit:
 - 30" (76.2 cm) and 36" (91.4 cm) models - A UL listed 40 amp power supply cord kit
 - 48" (121.9 cm) models - A UL listed 50 amp power supply cord kit marked for use with nominal 1⅜" (34.93 mm) diameter connection openings
- A UL listed strain relief
- UL listed wire connectors
- All models must be installed with a backguard if installing at zero clearance to a combustible backwall. See “Cabinet Dimensions” in the “Location Requirements” section for installation requirements.
 - 30" (76.2 cm) Adjustable Backguard
Order Part Number 8285148
 - 36" (91.4 cm) Adjustable Backguard
Order Part Number 8284756
 - 48" (121.9 cm) Adjustable Backguard
Order Part Number 8284755
 - 9" (22.9 cm) Backguard for 30" (76.2 cm) Ranges
Order Part Number W10115773
 - 9" (22.9 cm) Backguard for 36" (91.4 cm) Ranges
Order Part Number W10115776
 - 9" (22.9 cm) Backguard for 48" (121.9 cm) Ranges
Order Part Number W10115777
 - 22" (55.9 cm) Backguard with Shelf for 30" (76.2 cm) Ranges
Order Part Number W10225950
 - 22" (55.9 cm) Backguard with Shelf for 36" (91.4 cm) Ranges
Order Part Number W10225949
 - 22" (55.9 cm) Backguard with Shelf for 48" (121.9 cm) Ranges
Order Part Number W10225948

To order, see the “Assistance or Service” section of the Use and Care Guide.

Additional Parts Needed on Steam-Assist Models

- Tubing staples/retainers
- ¼" O.D. flexible codes approved water supply tubing (to make water connection)
- Water connection device (to connect ¼" O.D. tubing to water source). Check local codes for type of connection required.

Check local codes and consult gas supplier. Check existing gas supply and electrical supply. See “Electrical Requirements” and “Gas Supply Requirements” sections.

It is recommended that all electrical connections be made by a licensed, qualified electrical installer.

High Altitude Conversion

To convert the cooktop for elevations above 6,560 ft (1999.5 m), order a High Altitude Conversion Kit.

- Part Number W10394296 - LP high altitude
- Part Number W10394295 - Natural gas high altitude

To order, see the “Assistance or Service” section of the Use and Care Guide.

Location Requirements

IMPORTANT: Observe all governing codes and ordinances. Do not obstruct flow of combustion and ventilation air.

- It is the installer’s responsibility to comply with installation clearances specified on the model/serial rating plate. The model/serial rating plate is located on the right vertical surface of the oven door frame.
- It is recommended that a 600 CFM or larger range hood be installed above the range.
- It is not recommended that a microwave hood combination be mounted above the range.
- Recessed installations must provide complete enclosure of the sides and rear of the range.
- To eliminate the risk of burns or fire by reaching over heated surface units, cabinet storage space located above the surface units should be avoided. If cabinet storage is to be provided, the risk can be reduced by installing a range hood that projects horizontally a minimum of 5" (12.7 cm) beyond the bottom of the cabinets.
- All openings in the wall or floor where range is to be installed must be sealed.
- Do not seal the range to the side cabinets.
- Cabinet opening dimensions that are shown must be used. Given dimensions are minimum clearances.
- The anti-tip bracket must be installed. To install the anti-tip bracket shipped with the range, see “Install Anti-Tip Bracket” section.
- Grounded electrical supply is required. See “Electrical Requirements” section.
- Proper gas supply connection must be available. See “Gas Supply Requirements” section.
- Contact a qualified floor covering installer to check that the floor covering can withstand at least 200°F (93°C). Use an insulated pad or ¼" (0.64 cm) plywood over carpet and under range if installing range over carpeting.

IMPORTANT: To avoid damage to your cabinets, check with your builder or cabinet supplier to make sure that the materials used will not discolor, delaminate or sustain other damage. This oven has been designed in accordance with the requirements of UL and CSA International and complies with the maximum allowable wood cabinet temperatures of 194° (90°C).

Mobile Home - Additional Installation Requirements

The installation of this range must conform to the Manufactured Home Construction and Safety Standard, Title 24 CFR, Part 3280 (formerly the Federal Standard for Mobile Home Construction and Safety, Title 24, HUD Part 280). When such standard is not applicable, use the Standard for Manufactured Home Installations, ANSI A225.1/NFPA 501A or with local codes.

In Canada, the installation of this range must conform with the current standards CAN/CSA-Z240-latest edition, or with local codes.

Mobile home installations require:

- When this range is installed in a mobile home, it must be secured to the floor during transit. Any method of securing the range is adequate as long as it conforms to the standards listed above.

Product Dimensions

30" (76.2 cm) models

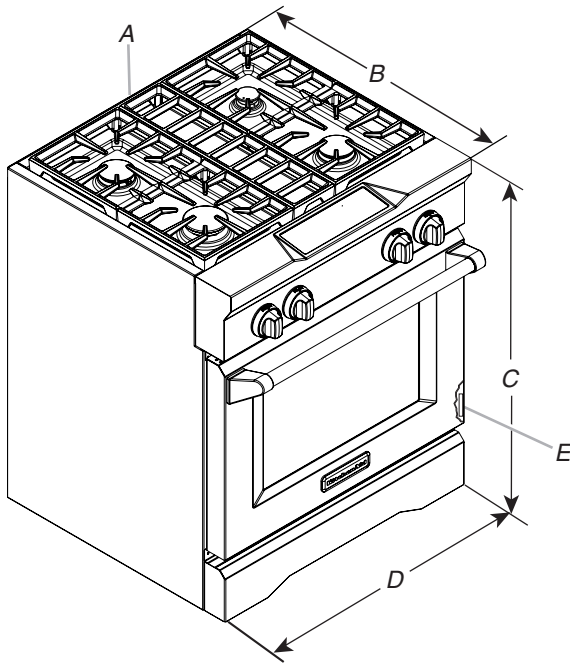

- A. Optional backguard may be installed.
- B. 27³/₄" (70.5 cm) depth with control panel, see NOTE*.
- C. 35³/₄" (90.8 cm) cooktop height when setting on the wheels
- D. 30" (76.2 cm) width
- E. Model/serial rating plate location

36" (91.4 cm) models

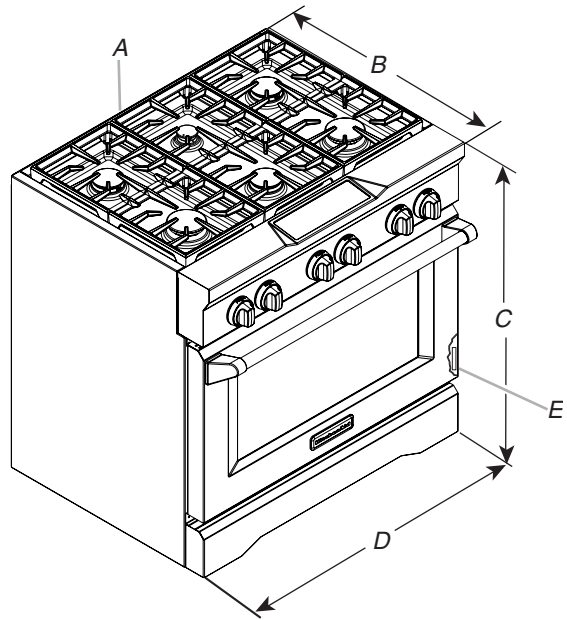

- A. Optional backguard may be installed.
- B. 27³/₄" (70.5 cm) depth with control panel, see NOTE*.
- C. 35³/₄" (90.8 cm) cooktop height when setting on the wheels
- D. 36" (91.4 cm) width
- E. Model/serial rating plate location

48" (121.9 cm) models

NOTE: The following illustration is for dimension planning purposes only, and the locations and appearances of the features shown may not match those of your model.

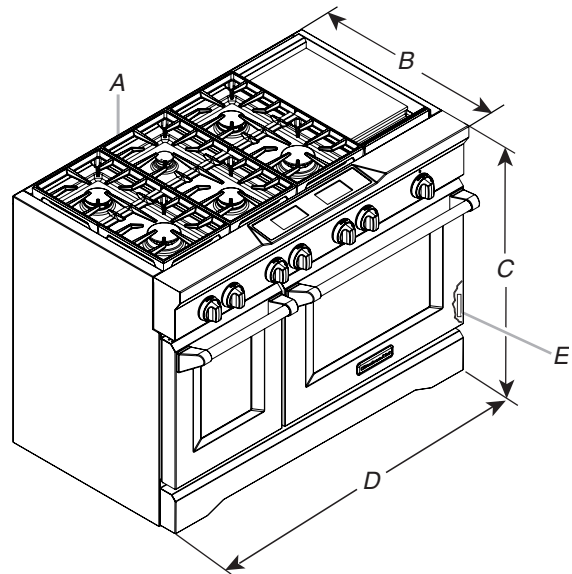

- A. Optional backguard may be installed.
- B. 27³/₄" (70.5 cm) depth with control panel, see NOTE*.
- C. 35³/₄" (90.8 cm) cooktop height when setting on the wheels
- D. 48" (121.9 cm) width
- E. Model/serial rating plate location

***NOTE:** When installed in a 24" (61.0 cm) base cabinet with 25" (63.5 cm) countertop; front of oven door protrudes 1⁷/₈" (4.8 cm) beyond 24" (61.0 cm) base cabinet.

Cabinet Dimensions

Cabinet opening dimensions shown are for 25" (64 cm) countertop depth, 24" (61 cm) base cabinet depth and 36" (91.4 cm) countertop height. Dimensions must be met in order to ensure a flush fit to back wall.

IMPORTANT: If installing a range hood or a hood liner above the range, follow the range hood or hood liner installation instructions for dimensional clearances above the cooktop surface.

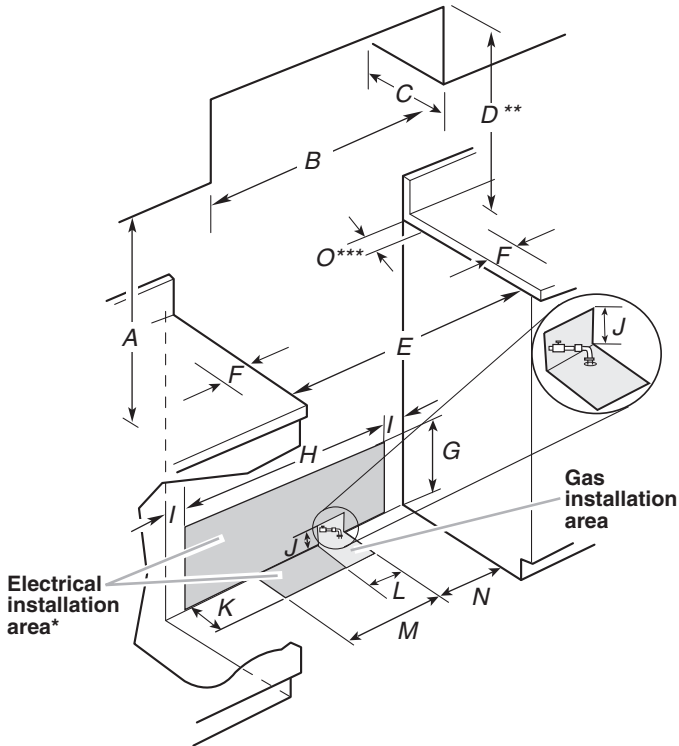

- A. 18" (45.7 cm) upper cabinet to countertop
- B. 30" (76.2 cm) model: 30" (76.2 cm) min. upper cabinet width
36" (91.4 cm) model: 36" (91.4 cm) min. upper cabinet width
48" (121.9 cm) model: 48" (121.9 cm) min. upper cabinet width
- C. 13" (33 cm) max. upper cabinet depth
- D. For minimum clearance to top of range, see NOTE**.
- E. 30¹/₄" (76.8 cm) on 30" (76.2 cm) models
36¹/₄" (92.1 cm) on 36" (91.4 cm) models
48¹/₄" (122.6 cm) on 48" (121.9 cm) models
- F. 6" (15.2 cm) min. clearance from both sides of range to side wall or other combustible material
- G. 15" (38.1 cm)
- H. 22" (55.9 cm) on 30" (76.2 cm) models
28" (71.1 cm) on 36" (91.4 cm) models
40" (101.6 cm) on 48" (121.9 cm) models
- I. 1¹/₂" (3.8 cm)
- J. 3" (7.6 cm)
- K. 5" (12.7 cm)
- L. 6" (15.2 cm) on 30" (76.2 cm) models
14" (35.5 cm) on 36" (91.4 cm) models
24" (61.0 cm) on 48" (121.9 cm) models
- M. 10¹/₂" (26.7 cm)
- N. 6" (15.2 cm)
- O. 6" (15.2 cm), see NOTE***

*NOTE: Receptacle must be rotated 90° for Canadian installation.

**NOTE: Minimum Clearances

30" (76.2 cm) models: 30" (76.2 cm) minimum clearance between the top of the cooking platform and the bottom of an uncovered wood or metal cabinet.

36" (91.4 cm) models: 42" (106.7 cm) minimum clearance between the top of the cooking platform and the bottom of an uncovered wood or metal cabinet.

48" (121.9 cm) models: 42" (106.7 cm) minimum clearance between the top of the cooking platform and the bottom of an uncovered wood or metal cabinet.

***NOTE: If backwall is constructed of a combustible material and a backguard is not installed, a 6" (15.2 cm) minimum clearance is required for all models.

Water Filtration System Location Requirements (on some models)

For best results, do not install the water filtration system outside, or in extreme hot or cold temperatures. Temperature of water supply to the water filtration system must be between 40°F/4°C and 100°F/38°C. Do not install on hot water supply line.

Locate the water filtration system near the cold water supply pipe under the kitchen sink to filter cold water.

Make sure that the water filter assembly is installed in the upright position.

It will be necessary to drill a 1/2" (1.3 cm) minimum diameter hole in the upper right or left rear corner of the side wall of the cabinet under the sink to route the water supply tubing through to the range.

Depending on your installation configuration, more routing holes may be required.

Coil enough flexible codes approved water supply tubing behind the range to allow for the connection to the range to be made behind the range prior to setting the range in place.

Typical Installation Configuration

NOTE: For unique installations, contact a licensed plumber.

In Massachusetts, a licensed plumber is required and the Commonwealth of Massachusetts Plumbing Code 248-CMR shall be adhered to.

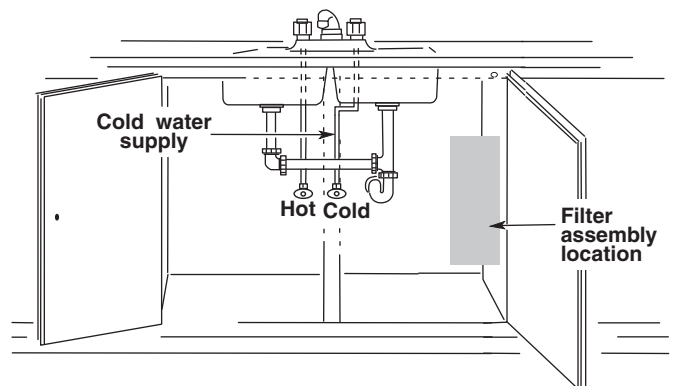

Water Supply Requirements

A cold water supply with water pressure between 30 and 120 psi (207 and 827 kPa) is required to operate the steam feature. In Massachusetts, plumbing code 248 CMR 3.00 and 10.00 must be followed and a licensed plumber shall be used. If you have questions about your water pressure, call a licensed, qualified plumber.

Reverse Osmosis Water Supply

IMPORTANT: The pressure of the water supply coming out of a reverse osmosis system going to the water inlet valve of the range needs to be between 30 and 120 psi (207 and 827 kPa).

If a reverse osmosis water filtration system is connected to your cold water supply, the water pressure to the reverse osmosis system needs to be a minimum of 40 psi (276 kPa).

If the water pressure to the reverse osmosis system is less than 40 psi (276 kPa):

- Check to see whether the sediment filter in the reverse osmosis system is blocked. Replace the filter if necessary.
- Allow the storage tank on the reverse osmosis system to refill after heavy usage.

If you have questions about your water pressure, call a licensed, qualified plumber.

Electrical Requirements - U.S.A. Only

If codes permit and a separate ground wire is used, it is recommended that a qualified electrical installer determine that the ground path and wire gauge are in accordance with local codes.

If codes permit and a separate ground wire is used, it is recommended that a qualified electrician determine that the ground path is adequate.

Do not use an extension cord.

Be sure that the electrical connection and wire size are adequate and in conformance with the National Electrical Code, ANSI/NFPA 70-latest edition and all local codes and ordinances.

A copy of the above code standards can be obtained from:
National Fire Protection Association
1 Batterymarch Park
Quincy, MA 02169-7471

WARNING: Improper connection of the equipment-grounding conductor can result in a risk of electric shock. Check with a qualified electrician or service technician if you are in doubt as to whether the appliance is properly grounded. Do not modify the power supply cord plug. If it will not fit the outlet, have a proper outlet installed by a qualified electrician.

Electrical Connection

To properly install your range, you must determine the type of electrical connection you will be using and follow the instructions provided for it here.

- Range must be connected to the proper electrical voltage and frequency as specified on the model/serial number rating plate. The model/serial number rating plate is located on the right vertical surface of the oven door frame. Refer to the illustrations in the "Product Dimensions" section of the "Location Requirements" section.

- This range may be manufactured with a 4-wire power supply cord, or it may not include a power supply cord. If your range does not include a power supply cord, use a 4-wire power supply cord rated at 250 volts, 40 or 50 amps and investigated for use with ranges.

Range Rating*		Specified Rating of Power Supply Cord Kit and Circuit Protection	
120/240 Volts	120/208 Volts	Amps	Range Size
8.8 - 16.5 kW	7.8 - 12.5 kW	40 or 50**	30" (76.2 cm), 36" (91.4 cm)
16.6 - 22.5 kW	12.6 - 18.5 kW	50	48" (121.9 cm)

*The NEC calculated load is less than the total connected load listed on the model/serial rating plate.

**If connecting to a 50-amp circuit, use a 50-amp rated cord with kit. For 50-amp rated cord kits, use kits that specify use with a nominal 1 $\frac{3}{8}$ " (34.9 mm) diameter connection opening.

- A circuit breaker is recommended.
- Wire sizes and connections must conform with the rating of the range.
- The Tech Sheet is located behind the kick plate in a clear plastic bag.

If connecting to a 4-wire system:

This range is manufactured with the ground connected to the cabinet. The ground must be revised so the green ground wire of the 4-wire power supply cord is connected to the cabinet. See the "Electrical Connection - U.S.A. Only" section.

Grounding through the neutral conductor is prohibited for new branch-circuit installations (1996 NEC); mobile homes; and recreational vehicles, or an area where local codes prohibit grounding through the neutral conductor.

When a 4-wire receptacle of NEMA Type 14-50R is used, a matching UL listed, 4-wire, 250-volt, 40- or 50-amp, range power supply cord must be used. This cord contains 4 copper conductors with ring terminals or open-end spade terminals with upturned ends, terminating in a NEMA Type 14-50R plug on the supply end.

The fourth (grounding) conductor must be identified by a green or green/yellow cover and the neutral conductor by a white cover. Cord should be Type SRD or SRDT with a UL listed strain relief and be at least 4 ft (1.22 m) long.

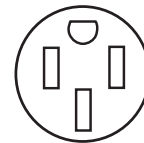

4-wire receptacle (14-50R)

The minimum conductor sized for the copper 4-wire power cord are:

- 40-amp circuit
- 2 No.-8 conductors
- 1 No.-10 white neutral
- 1 No.-10 green grounding

If connecting to a 3-wire system:

Local codes may permit the use of a UL listed, 3-wire, 250-volt, 40- or 50-amp range power supply cord (pigtail). This cord contains 3 copper conductors with ring terminals or open-end spade terminals with upturned ends, terminating in a NEMA Type 10-50P plug on the supply end. Connectors on the appliance end must be provided at the point the power supply cord enters the appliance. This uses a 3-wire receptacle of NEMA Type 10-50R.

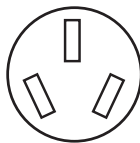

3-wire receptacle (10-50R)

Electrical Requirements - Canada Only

⚠ WARNING



Electrical Shock Hazard

Electrically ground range.

Failure to do so can result in death, fire, or electrical shock.

If codes permit and a separate ground wire is used, it is recommended that a qualified electrical installer determine that the ground path and wire gauge are in accordance with local codes.

Be sure that the electrical connection and wire size are adequate and in conformance with the CSA Standard C22.1, Canadian Electrical Code, Part 1 - latest edition, and all local codes and ordinances.

A copy of the above code standards can be obtained from:

Canadian Standards Association
178 Rexdale Blvd.
Toronto, ON M9W 1R3 CANADA

- Check with a qualified electrical installer if you are not sure the range is properly grounded.
- When a 4-wire, single phase 250 volt, 60 Hz., AC only electrical supply is available, a 40-amp minimum circuit protection is required on 30" (76.2 cm) and 36" (91.4 cm) ranges and a 50-amp minimum circuit protection is required on 48" (121.9 cm) ranges, fused on both sides of the line.
- A time-delay fuse or circuit breaker is recommended.
- This range is equipped with a CSA International Certified Power Cord intended to be plugged into a standard 14-50R wall receptacle. Be sure the wall receptacle is within reach of range's final location.

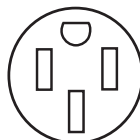

- Do not use an extension cord.

Gas Supply Requirements

⚠ WARNING



Explosion Hazard

Use a new CSA International approved gas supply line.

Install a shut-off valve.

Securely tighten all gas connections.

If connected to LP, have a qualified person make sure gas pressure does not exceed 14" (36 cm) water column.

Examples of a qualified person include:

**licensed heating personnel,
authorized gas company personnel, and
authorized service personnel.**

Failure to do so can result in death, explosion, or fire.

Observe all governing codes and ordinances.

IMPORTANT: This installation must conform with all local codes and ordinances. In the absence of local codes, installation must conform with American National Standard, National Fuel Gas Code ANSI Z223.1/NFPA 54 - latest edition or CAN/CGA B149 - latest edition.

IMPORTANT: Range cooktop must be connected to a regulated gas supply.

IMPORTANT: Leak testing of the range cooktop must be conducted according to the manufacturer's instructions.

Type of Gas

Natural Gas:

- This range is factory set for use with Natural gas. The model/serial rating plate located on the right vertical surface of the oven door frame has information on the types of gas that can be used. If the types of gas listed do not include the type of gas available, check with the local gas supplier.

LP Gas conversion:

Conversion must be done by a qualified service technician.

No attempt shall be made to convert the range cooktop from the gas specified on the model/serial rating plate for use with a different gas without consulting the serving gas supplier. To convert to LP gas, use the LP gas conversion kit provided with your range and see the "LP Gas Conversion" section. The parts for this kit are in the literature package supplied with the range.

Gas Supply Line

- Provide a gas supply line of $\frac{3}{4}$ " (1.9 cm) rigid pipe to the range location. A smaller size pipe on longer runs may result in insufficient gas supply. With LP gas, piping or tubing size can be $\frac{1}{2}$ " (1.3 cm) minimum. Usually, LP gas suppliers determine the size and materials used in the system.

NOTE: Pipe-joint compounds that resist the action of LP gas must be used. Do not use TEFLON[†] tape.

Flexible metal appliance connector:

- If local codes permit, a new CSA design-certified, 4 - 5 ft (122 - 152.4 cm) long, $\frac{5}{8}$ " (1.6 cm) or $\frac{3}{4}$ " (1.9 cm) I.D., flexible metal appliance connector may be used for connecting range to the gas supply line.



- A $\frac{1}{2}$ " (1.3 cm) male pipe thread is needed for connection to the female pipe threads of the inlet to the range pressure regulator.
- Do not kink or damage the flexible metal tubing when moving the range.
- Must include a manual shutoff valve:
The supply line must be equipped with a manual shutoff valve. This valve should be located in the same room but external to the range opening, such as an adjacent cabinet. It should be in a location that allows ease of opening and closing. Do not block access to shutoff valve. The valve is for turning on or shutting off gas to the range.

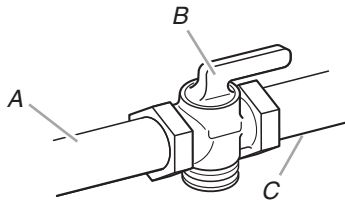

A. Gas supply line
B. Shutoff valve "open" position
C. To range

Gas Pressure Regulator

The gas pressure regulator supplied with this range must be used. The inlet pressure to the regulator should be as follows for proper operation:

Natural Gas:

Minimum pressure: 6" (15.2 cm) WCP

Maximum pressure: 14" (35.6 cm) WCP

LP Gas:

Minimum pressure: 11" (27.9 cm) WCP

Maximum pressure: 14" (35.6 cm) WCP

Contact local gas supplier if you are not sure about the inlet pressure.

Burner Input Rating - Altitude

Input ratings shown on the model/serial rating plate are for elevations up to 2,000 ft (609.6 m).

For elevations above 2,000 ft (609.6 m), ratings need to be reduced at a rate of 4% for each 1,000 ft (304.8 m).

Gas Supply Pressure Testing

Gas supply pressure for testing regulator must be at least 1" water column pressure above the manifold pressure shown on the model/serial rating plate.

Line pressure testing above $\frac{1}{2}$ psi gauge (14" WCP)

The range and its individual shutoff valve must be disconnected from the gas supply piping system during any pressure testing of that system at test pressures in excess of $\frac{1}{2}$ psi (3.5 kPa).

Line pressure testing at $\frac{1}{2}$ psi gauge (14" WCP) or lower

The range must be isolated from the gas supply piping system by closing its individual manual shutoff valve during any pressure testing of the gas supply piping system at test pressures equal to or less than $\frac{1}{2}$ psi (3.5 kPa).

[†]TEFLON is a registered trademark of E.I. Du Pont De Nemours and Company.

INSTALLATION INSTRUCTIONS

Unpack Range

⚠ WARNING

Excessive Weight Hazard

Use two or more people to move and install range.
Failure to do so can result in back or other injury.

1. Remove shipping materials, tape and film from range. Keep shipping pallet under range. Remove oven racks, grates and parts package from inside oven.
2. Remove screws from kick plate.

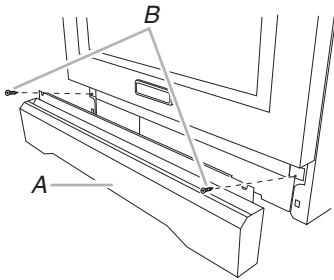

A. Kick plate
B. Remove these screws.

3. Lift up on kick plate to release plate from shoulder screws.
4. Lay kick plate to the side to avoid scratching the stainless steel.
5. For 48" (121.9 cm) models only, rotate center support counterclockwise off the pallet until it stops.

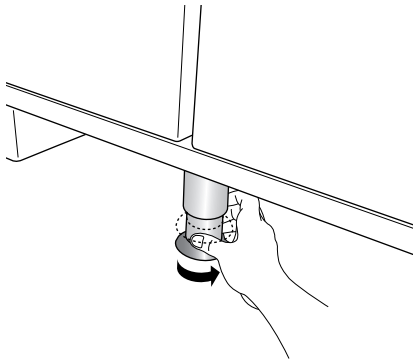

NOTE: This support is used only for shipping and is not needed for installation.

6. Lay a piece of cardboard from side packing on the floor behind range. Using 2 or more people, firmly grasp each side of range. Lift range up about 3" (8.0 cm) and move it back until range is off shipping pallet. Set range on cardboard to avoid damaging floor.

Install Optional Backguard

All ranges may require a backguard. See "Cabinet Dimensions" in the "Location Requirements" section. See the "Tools and Parts" section for information on ordering.

Remove island trim and attach backguard using 6 screws, insert 3 from the front and 3 from the back (9" [22.9 cm] backguard is shown).

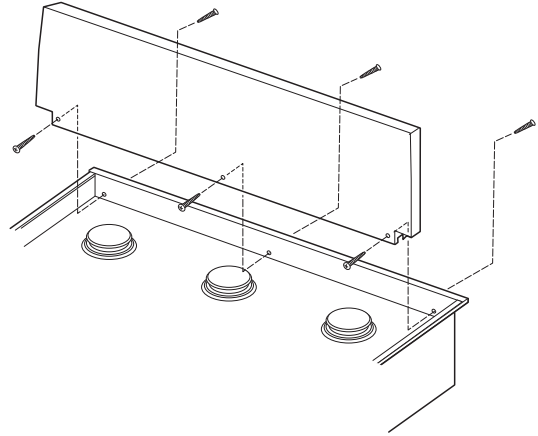

Install Anti-Tip Bracket

⚠ WARNING

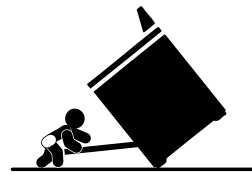

Tip Over Hazard

A child or adult can tip the range and be killed.

Install anti-tip bracket to floor or wall per installation instructions.

Slide range back so rear range foot is engaged in the slot of the anti-tip bracket.

Re-engage anti-tip bracket if range is moved.

Do not operate range without anti-tip bracket installed and engaged.

Failure to follow these instructions can result in death or serious burns to children and adults.

1. Determine which mounting method to use: floor or wall.
If you have a stone or masonry floor, you can use the wall mounting method.

- Determine and mark centerline of the cutout space. The mounting bracket must be installed on the right side of the cutout. Position mounting bracket in cutout as shown in the following illustration.

Measurement B:

30" (76.2 cm) ranges: 11 $\frac{5}{8}$ " (29.5 cm)

36" (91.4 cm) ranges: 14 $\frac{5}{8}$ " (37.1 cm)

48" (121.9 cm) ranges: 20 $\frac{5}{8}$ " (52.4 cm)

Measurement C:

Optional distance from back wall. If back wall is constructed of a combustible material and a backguard is not installed, a 6" (15.2 cm) minimum clearance is required for all models. Install anti-tip bracket accordingly.

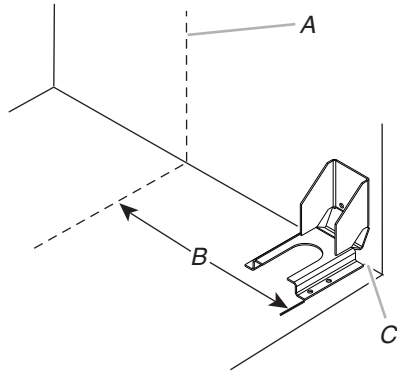

- A. Centerline
- B. Centerline of cutout to centerline of anti-tip bracket
- C. Back wall to back of range

- Drill two $\frac{1}{8}$ " (3.0 mm) holes that correspond to the bracket holes of the determined mounting method. See the following illustrations.

Floor Mounting

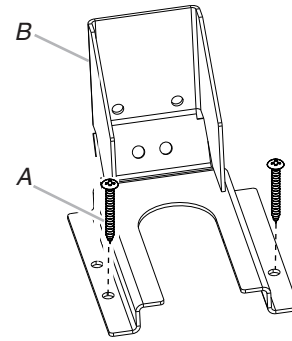

- A. #12 x 1 $\frac{5}{8}$ " screws
- B. Anti-tip bracket

Wall Mounting

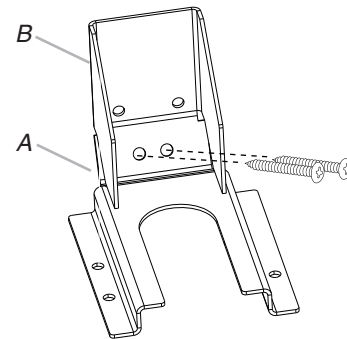

- A. #12 x 1 $\frac{5}{8}$ " screws
- B. Anti-tip bracket

- Using a Phillips screwdriver, mount anti-tip bracket to the wall or floor with the two #12 x 1 $\frac{5}{8}$ " screws provided. Depending on the thickness of your flooring, longer screws may be necessary to anchor the bracket to the subfloor. Longer screws are available from your local hardware store.
- Move range close enough to opening to allow for electrical connections to be made. Remove shipping base, cardboard or hardboard from under range.
- Continue installing your range using the following installation instructions.

Electrical Connection - U.S.A. Only

30" (76.2 cm) and 36" (91.4 cm) Models

48" (121.9 cm) Models

⚠ WARNING



Electrical Shock Hazard

Disconnect power before servicing.
Use a new 40 amp power supply cord.
Plug into a grounded outlet.
Failure to follow these instructions can result in death, fire, or electrical shock.

⚠ WARNING



Electrical Shock Hazard

Disconnect power before servicing.
Use a new 50 amp power supply cord.
Plug into a grounded outlet.
Failure to follow these instructions can result in death, fire, or electrical shock.

1. Disconnect power.
2. Remove the terminal block cover screws and disengage mounting tabs to remove terminal block cover from back of range.

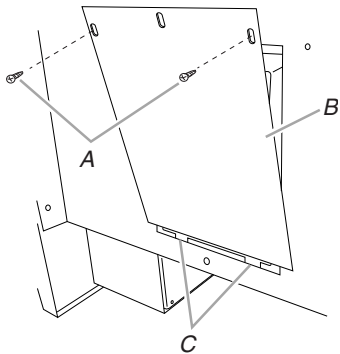

A. Phillips head screws
 B. Terminal block cover
 C. Two mounting tabs at bottom

3. Add power supply cord strain relief.
 - Assemble a UL listed strain relief in the opening.

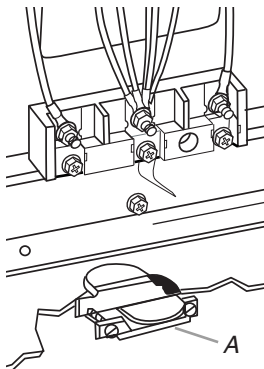

A. UL listed strain relief

- Tighten strain relief screw against the power supply cord.

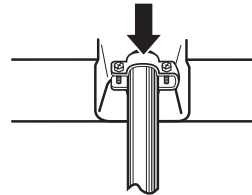

4. Complete installation following instructions for your type of electrical connection:
 - 4-wire** (recommended)
 - 3-wire** (if 4-wire is not available)

Electrical Connection Options

If your home has:	And you will be connecting to:	Go to Section:
4-wire receptacle (NEMA type 14-50R) <div style="text-align: center;"> </div>	A UL listed, 250-volt minimum, 40- or 50-amp, range power supply cord	4-wire connection: Power supply cord
3-wire receptacle (NEMA type 10-50R) <div style="text-align: center;"> </div>	A UL listed, 250-volt minimum, 40- or 50-amp, range power supply cord	3-wire connection: Power supply cord

4-wire connection: Power supply cord

Use this method for:

- New branch-circuit installations (1996 NEC)
- Mobile homes
- Recreational vehicles
- In an area where local codes prohibit grounding through the neutral

1. Remove the ground-link screw from the range frame. Save the ground-link screw. Bend the ground link away from the range so that it does not contact the range.

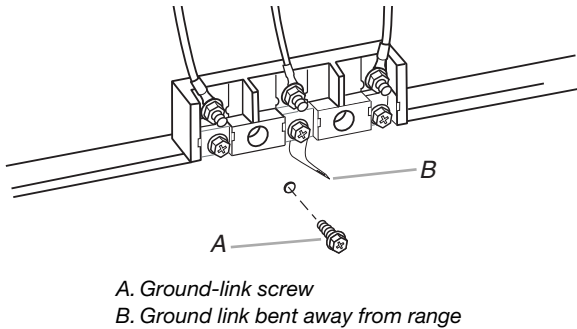

2. Connect the green ground wire from the power supply cord to the range using the ground-link screw. The ground wire must be attached first and must not contact any other terminal.
3. Use a ¼" nut driver to remove the hex washer head screws from the terminal blocks.
4. Connect the neutral (center) wire to the center terminal connector using one of the hex washer head screws. Securely tighten screw for proper electrical connection.

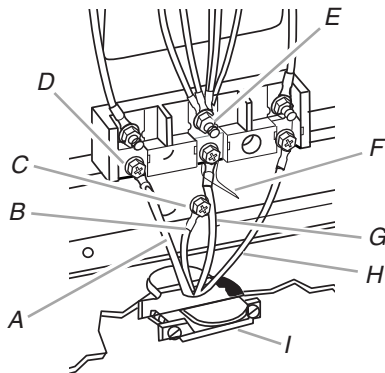

5. Connect the other 2 wires (lines 1 and 2) to the outer aluminum terminal blocks.
6. Securely tighten screws for proper electrical connection.
7. Tighten strain relief screws.
8. Replace terminal block cover.

3-wire connection: Power supply cord

Use this method only if local codes permit connecting cabinet-ground conductor to neutral wire of power supply cord.

1. Use a ¼" nut driver and remove the hex washer head screws from the aluminum terminal blocks.

2. Connect the neutral (center) wire to the center terminal connector using one of the hex washer head screws. Securely tighten screw for proper electrical connection.

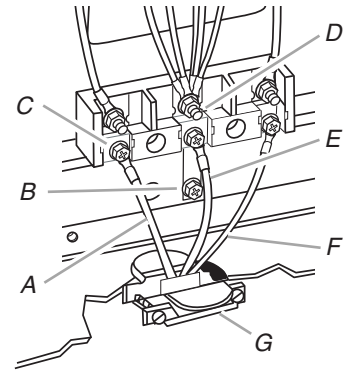

3. Connect the other 2 wires (lines 1 and 2) to the outer terminal screws on the terminal block.
4. Tighten strain relief screws.
5. Replace terminal block cover.

Install Water Filtration System (on some models)

Install Model W10049700 Water Filter

1. Install the water filter near the cold water supply pipe under the kitchen sink to filter the cold water.

IMPORTANT: Be sure to allow a minimum clearance of 1½" (3.8 cm) under the filter system for removing the filter cartridge.

Make sure that the water filter assembly is installed in the upright position.

Typical Installation Configuration

NOTE: For unique installations, contact a licensed plumber.

In Massachusetts, a licensed plumber is required and the Commonwealth of Massachusetts Plumbing Code 248-CMR shall be adhered to.

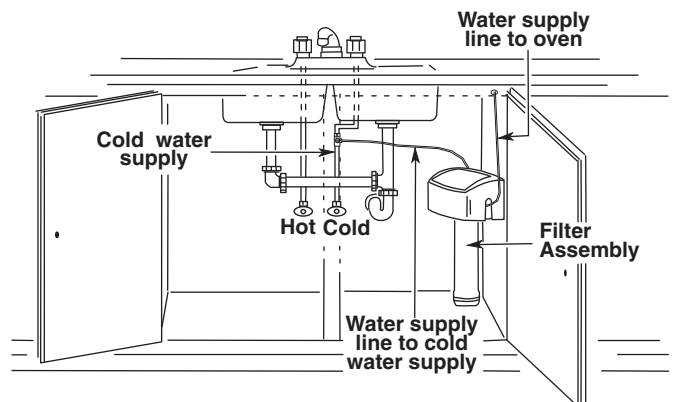

2. Attach the supplied water filter mounting ring and screw at the recommended location.

- Attach filter to the mounting ring.

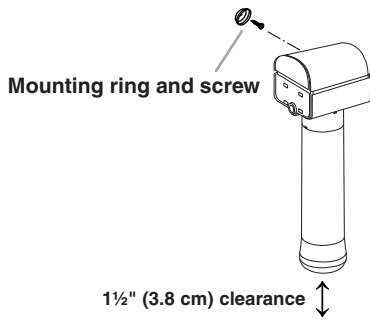

If you need to release tubing:

Push in collet to release tubing. With collet held in, pull tubing straight out.

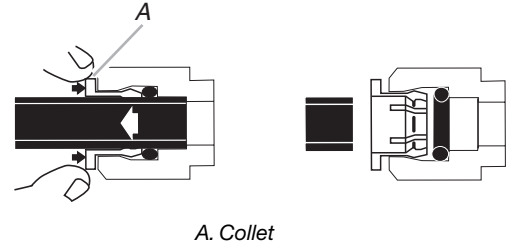

Connect to Home Water Supply

- Make connection to the cold water supply line.
 - A leak-tight connection to the 1/4" flexible codes approved water supply line must be provided.
 - Check local codes for type of connection required.
 - Flexible codes approved water supply line must be cut with a tubing cutter so the ends are concentric and without burrs.

NOTE: It is recommended that the cold water line be soft water.

Connect to Water Filter Inlet (yellow)

NOTE: Use the quick connect stem and/or elbow adapter fittings in the combination needed for your installation configuration.

- Attach the supplied 3/8" to 1/4" stem or 3/8" to 1/4" elbow quick connect adapter fitting to the yellow water filter inlet connection by pushing the quick connect fitting past the O-ring until you hit the backstop.

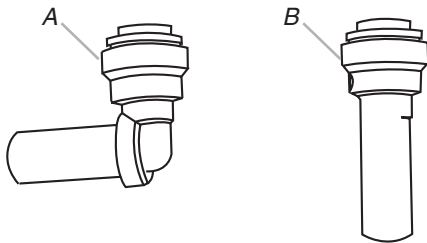

- Connect the flexible codes approved water supply line (not provided) from the home cold water supply pipe to the quick connect adapter fitting you just installed on the filter inlet (yellow) side of the water filter.
- Pull tube to ensure it is secured.

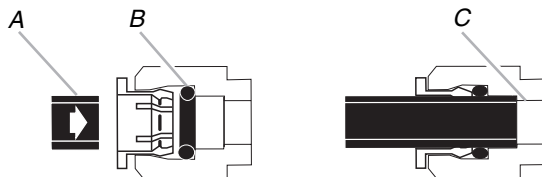

A. 1/4" water supply tubing
B. O-ring
C. Backstop

Connect to Water Filter Outlet (blue)

- Attach the supplied 3/8" to 1/4" stem or 3/8" to 1/4" elbow quick connect adapter fitting to the blue water filter outlet connection by pushing the quick connect fitting past the O-ring until you hit the backstop.
- Connect another piece of flexible codes approved water supply line to the quick connect adapter fitting you just installed on the filter outlet (blue) side of the water filter.
- Pull tube to ensure it is secured.

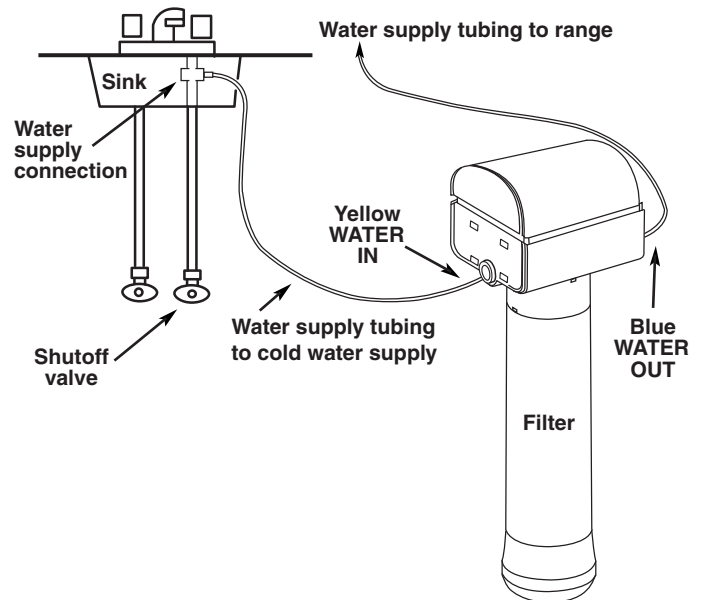

- Route flexible codes approved water supply line through undersink cabinet and oven cabinet cutout.

- Connect the flexible codes approved water supply line to the range copper tubing, using a 1/4" to 1/4" water supply union.

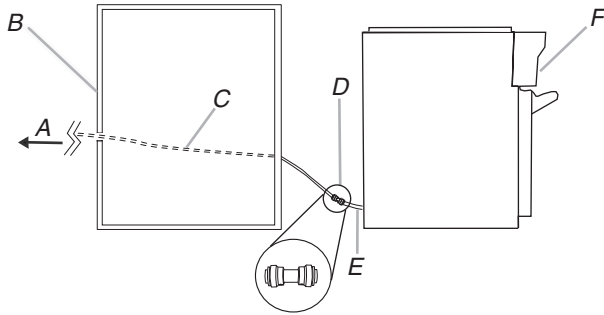

- A. To home water supply
- B. Rear of cabinet cutout
- C. Flexible codes approved water supply line from home water supply
- D. 1/4" to 1/4" water supply union (supplied in water filter kit)
- E. Oven copper tubing
- F. Range front

- Turn on water supply.
- Check all connections for leaks.

NOTE: No flushing or conditioning of the water filter is required prior to use.

- Use a 15/16" combination wrench and channel lock pliers to attach the flexible connector to the adapters. Check that connector is not kinked.

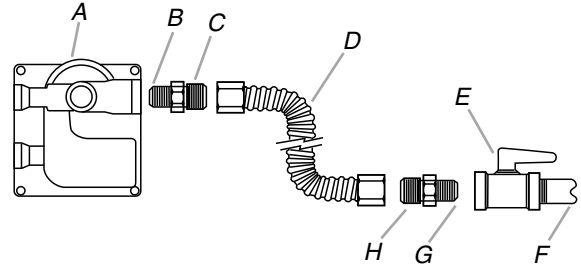

- A. Gas pressure regulator
- B. Use pipe-joint compound.
- C. Adapter (must have 1/2" male pipe thread)
- D. Flexible connector
- E. Manual gas shutoff valve
- F. 1/2" or 3/4" gas pipe
- G. Use pipe-joint compound.
- H. Adapter

Complete Connection

- Open the manual shutoff valve in the gas supply line. The valve is open when the handle is parallel to the gas pipe.

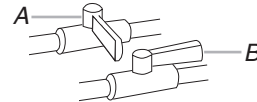

- A. Closed valve
- B. Open valve

Make Gas Connection

WARNING



Explosion Hazard

Use a new CSA International approved gas supply line.

Install a shut-off valve.

Securely tighten all gas connections.

If connected to LP, have a qualified person make sure gas pressure does not exceed 14" (36 cm) water column.

Examples of a qualified person include:
licensed heating personnel,
authorized gas company personnel, and
authorized service personnel.

Failure to do so can result in death, explosion, or fire.

- Assemble flexible connector from gas supply pipe to pressure regulator located in the middle rear of the range.
- Apply pipe-joint compound made for use with LP gas to the smaller thread ends of the flexible connector adapters (see B and G in the following illustration).
- Attach one adapter to the gas pressure regulator and the other adapter to the gas shutoff valve. Tighten both adapters, being certain not to move or turn the gas pressure regulator.

- Test all connections by brushing on an approved noncorrosive leak-detection solution. If bubbles appear, a leak is indicated. Correct any leak found.
- Remove cooktop burner caps, burner bases and grates from parts package. Place burner bases on cooktop. Place burner caps on burner bases. Place grates over burners and caps.
- Check that the range is plugged into the appropriate grounded outlet (see the "Electrical Requirements" section).
- Turn on power supply. For further information, please refer to the user instructions located in the Use and Care Guide.

Verify Anti-Tip Bracket Location

- Turn all 4 leveling rods 1 full turn to raise the range and provide enough clearance for the rear leveling leg to slide into the anti-tip bracket.

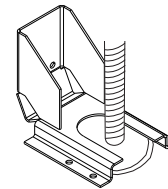

- Move range into its final location making sure rear leveling leg slides into anti-tip bracket.
- Use a flashlight to look underneath the bottom of the range and visually check that the rear range foot is inserted into the slot of the anti-tip bracket.

Level Range

NOTE: Range must be level for satisfactory baking performance.

1. Place rack in oven.
2. Place level on rack and check levelness of the range, first side to side; then front to back.

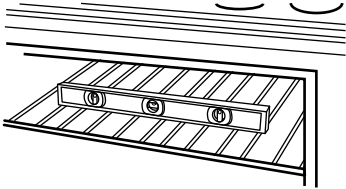

3. If range is not level, adjust the leveling rods. Turn leveling rods located behind the kick plate to level range and to raise or lower range to the desired countertop height.

NOTE: All roller feet must be off the floor upon final installation.

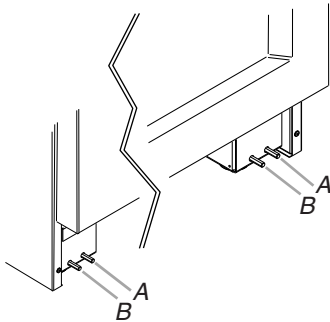

A. Front leveling rod
B. Rear leveling rod

Install Grill Grease Trays

(on grill models)

1. Remove flame spreader. Pull forward slightly on the flame spreader to release the tabs from the rear slots and lift out.

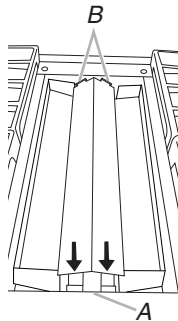

A. Grill front
B. Rear tabs and slots

2. Cut and remove tie strap from rear of burner assembly.

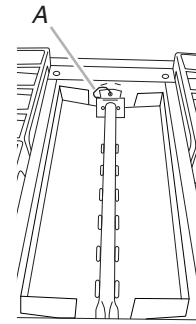

A. Tie strap

3. Lift burner assembly up and out to remove.
4. Slide drip tray into opening on the right front side of the grill basin. There are guides to assure correct placement of the drip tray.

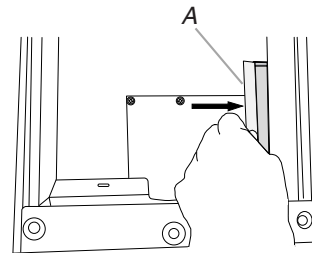

A. Drip tray

5. Insert the large grease tray all the way under the back edge of the grill basin and hook it into the slots.

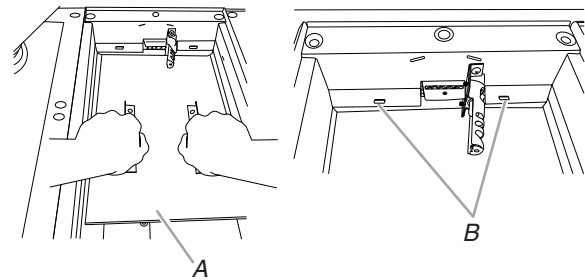

A. Large grease tray
B. Slots

6. Insert the small grease tray all the way under the front of the grill basin and hook it into the slots.

When the 2 grease trays are installed properly, the small grease tray will hook over the large grease tray.

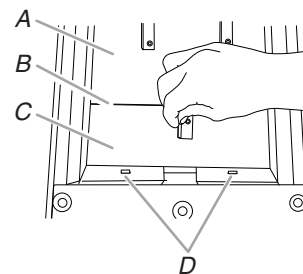

A. Large grease tray
B. Grease tray connection
C. Small grease tray
D. Slots

7. Insert the orifice tube on the front of the burner assembly into the opening at the front of the grill basin and set burner assembly into place.

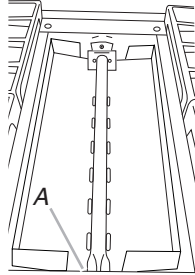

A. Front opening

8. Insert front tabs of the flame spreader into slots at the front of the grill basin, then the rear tabs into the rear slots.

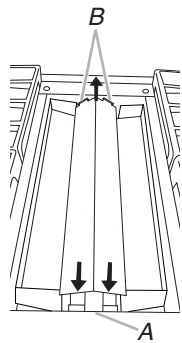

A. Front tabs and slots
B. Rear tabs and slots

9. Check the surface burner and grill flames. Refer to the "Electronic Ignition System" section.
10. Place the wave tray on top of the flame spreader.

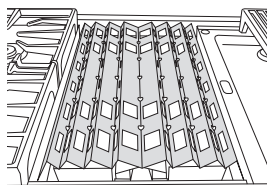

11. Place the grill grate into position.

Install Griddle (on griddle models)

The griddle is factory installed.

1. Place drip tray in the well at the front of the griddle. Slide tray toward the back until it stops.

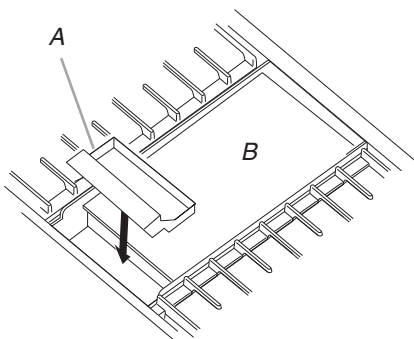

A. Griddle drip tray
B. Griddle

2. Clean griddle before using. Refer to the Use and Care Guide.

Electronic Ignition System

Install Burner Bases and Burner Caps

Install the burner base, making sure the igniter electrode is properly aligned with the base. Place burner caps on top of burner bases. If burner caps are not properly positioned, surface burners will not light.

20,000 Btu/h Ultra Power™ Dual-Flame Burner

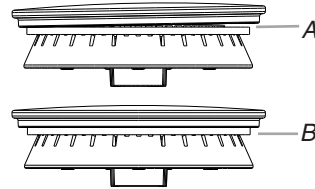

A. Incorrect
B. Correct

15,000 Btu/h Professional Burner

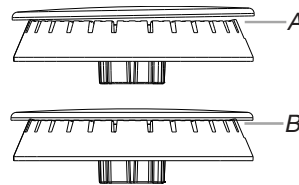

A. Incorrect
B. Correct

5,000 Btu/h Simmer/Melt Burner

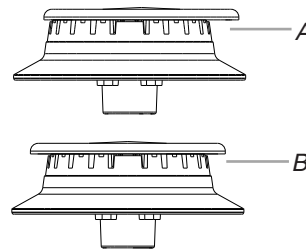

A. Incorrect
B. Correct

Initial Lighting and Gas Flame Adjustments

Cooktop burners use electronic igniters in place of standing pilots. When the cooktop control knob is turned to any position, the system creates a spark to light the burner. This sparking continues until the flame is lit or the knob is turned to Off.

Check Operation of Cooktop Burners

Push in and turn each control knob to LITE.

The surface burners and grill flames should light within 4 seconds. The first time a burner is lit, it may take longer than 4 seconds to light because of air in the gas line.

After verifying the proper burner operation, turn the control knobs to OFF.

If burners do not light properly:

- Turn cooktop control knob to OFF.
- Check that the range is plugged in and the circuit breaker has not tripped or the fuse has not blown.
- Check that the gas shutoff valves are set to the "open" position.
- Check that burner caps are properly positioned on burner bases.

Repeat start-up. If a burner does not light at this point, contact your dealer or authorized service company for assistance.

Flame Height

The cooktop flame should be a steady blue flame approximately ¼" (0.64 cm) high.

Dual Flame Burner

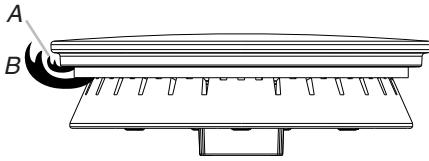

A. Upper (simmer) flame
B. Lower flame

Single Flame Burner

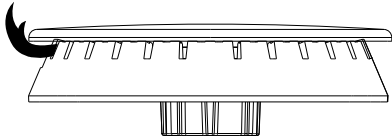

To Adjust Flame Height:

1. Unplug range or disconnect power.
2. Remove burner grates.
3. Remove the control knobs.
4. Open the oven door and remove the 2 screws on each side of the range that hold the control console in place.

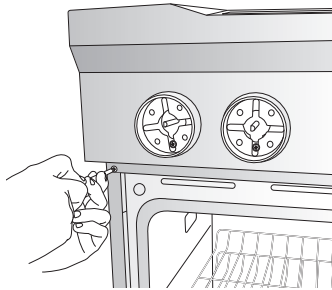

NOTE: Make sure to leave oven door open or the control console will not rest in the side brackets properly once it is detached.

5. Pull up on the control console and let it drop forward into the notched console brackets on each side.

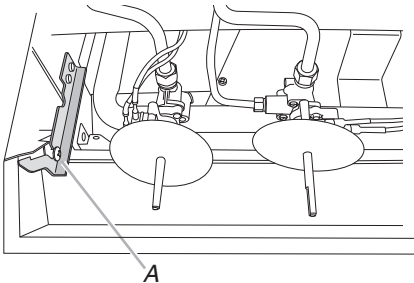

A. Control console bracket

6. Remove the round gasket from the valve stem.

7. Put a control knob onto the valve stem of the burner you want to adjust.

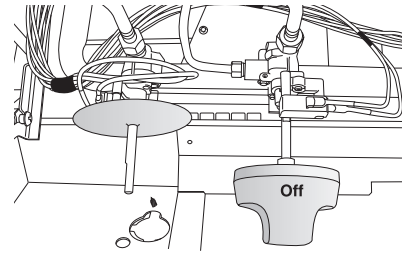

8. Turn the control knob to LO and using a butane extension lighter, light the burner.

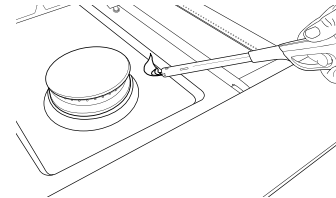

9. Remove the control knob.

10. Use a ⅛" x 4¼" flat-blade screwdriver to adjust the flame height. Tighten screw to reduce flame height. Loosen screw to increase flame height.

NOTE: When you are converting to LP gas, the screw should be tightened down completely on the single output valves. The dual output valve should not be adjusted.

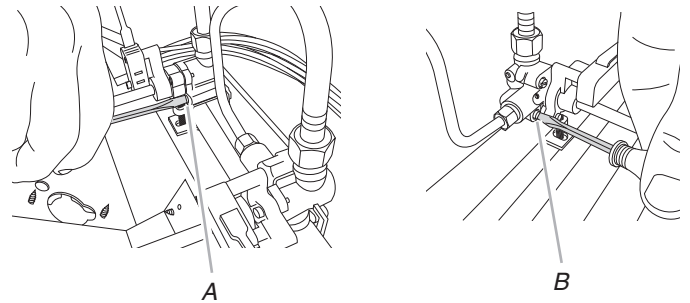

A. Single flame burner adjustment screw (on right side of valve)
B. Dual flame burner adjustment screw (on left side of valve)

11. When finished adjusting the flame height, put a control knob back onto the valve stem and turn off the burner.
12. Remove the control knob.
13. Replace the round gasket.
14. Repeat steps 6 through 13 for any other burners that need adjustment.
15. Lift up on the control console and set it back into place. For a proper fit, the flange of the control console must hook over the lip on the front of the range cooktop.

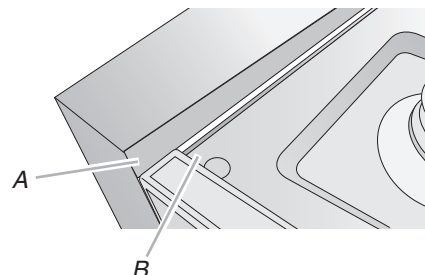

A. Control console flange
B. Front lip of range cooktop

16. Check that the control console is flush with the top edge of the range.

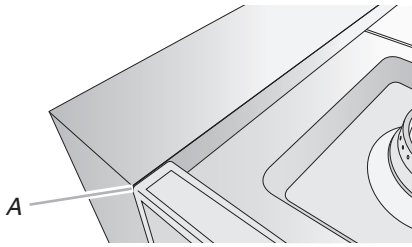

A. Flush with range top

17. Replace the 2 screws on each side of the control console.
18. Replace the control knobs.
19. Replace burner grates.
20. Test the flame by turning the control from LO to HI, checking the flame at each setting.

Reinstall Kick Plate

1. Align shoulder screw mounting holes with shoulder screws on range.
2. Push kick plate down against front of range until the top screw holes are aligned with the mounting holes on the front of the range.
3. Reattach screws to the top of the kick plate.

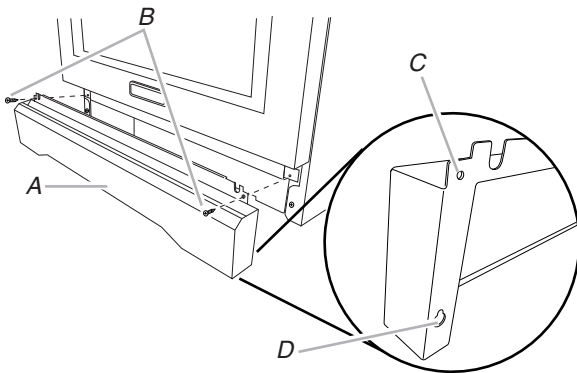

- A. Kick plate
 B. Reattach these screws.
 C. Top screw hole
 D. Shoulder screw mounting hole

Complete Installation

1. Check that all parts are now installed. If there is an extra part, go back through the steps to see which step was skipped.
2. Check that you have all of your tools.
3. Dispose of/recycle all packaging materials.
4. For oven use and cleaning, read the Use and Care Guide.

Check Operation of Oven(s)

1. Turn power on.
2. Start a Bake cycle. See the Use and Care Guide for operating instructions.

If oven(s) does not operate, check the following:

- Household fuse is intact and tight; or circuit breaker has not tripped.
 - Electrical supply is connected.
 - See "Troubleshooting" section in the Use and Care Guide.
3. When oven has been on for 10-15 minutes, open the oven door, and feel for heat.

If you do not feel heat or if an error code ("F" followed by a number plus "E" followed by a number) appears in the display, turn off the oven and contact a qualified technician.

4. Touch OFF.

To set the clock and other oven functions, refer to the Use and Care Guide.

If you need Assistance or Service:

Please reference the "Assistance or Service" section of the Use and Care Guide or contact the dealer from whom you purchased your range.

GAS CONVERSIONS

IMPORTANT: Gas conversions from Natural gas to LP gas must be done by a qualified installer.

⚠ WARNING



Explosion Hazard

Use a new CSA International approved gas supply line.

Install a shut-off valve.

Securely tighten all gas connections.

If connected to LP, have a qualified person make sure gas pressure does not exceed 14" (36 cm) water column.

Examples of a qualified person include:

licensed heating personnel,
authorized gas company personnel, and
authorized service personnel.

Failure to do so can result in death, explosion, or fire.

LP Gas Conversion

⚠ WARNING



Tip Over Hazard

A child or adult can tip the range and be killed.

Install anti-tip bracket to floor or wall per installation instructions.

Slide range back so rear range foot is engaged in the slot of the anti-tip bracket.

Re-engage anti-tip bracket if range is moved.

Do not operate range without anti-tip bracket installed and engaged.

Failure to follow these instructions can result in death or serious burns to children and adults.

1. Turn the manual shutoff valve to the closed position.

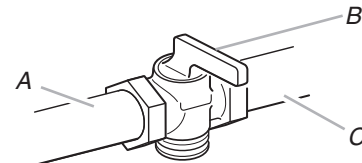

- A. To range
B. Shutoff valve (closed position)
C. Gas supply line

2. Unplug range or disconnect power.

To Convert Gas Pressure Regulator

1. Remove the access cap by using a wrench, turning the access cap counterclockwise.
2. Remove spring retainer from the cap by pushing against the flat side of the spring retainer. Look at the spring retainer to locate the "NAT" or "LP" position. Turn over the spring retainer so the "LP" is showing on the bottom. Snap the spring retainer back into the cap. Reinstall the cap onto the regulator.

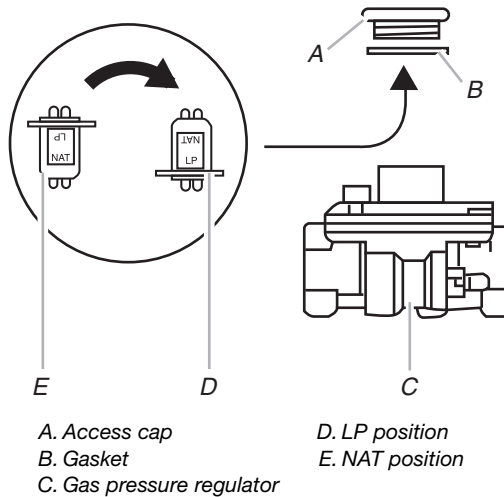

3. Test the gas pressure regulator and gas supply line. The regulator must be checked at a minimum 1" (2.5 cm) water column above the set pressure. The inlet pressure to the regulator should be as follows for operation and checking the regulator setting:

LP Gas:

Minimum pressure 11" (27.9 cm) WCP
Maximum pressure 14" (35.5 cm) WCP.

Gas Supply Pressure Testing

Gas supply pressure for testing regulator must be at least 1" water column pressure above the manifold pressure shown on the model/serial rating plate.

Line pressure testing above ½ psi gauge (14" WCP)

The range and its individual shutoff valve must be disconnected from the gas supply piping system during any pressure testing of that system at test pressures in excess of ½ psi (3.5 kPa).

Line pressure testing at ½ psi gauge (14" WCP) or lower

The range must be isolated from the gas supply piping system by closing its individual manual shutoff valve during any pressure testing of the gas supply piping system at test pressures equal to or less than ½ psi (3.5 kPa).

To Convert Surface Burners

1. If the burner grates are installed, remove them.
2. Remove burner cap.
3. Remove the burner base.

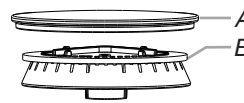

Large Dual Burner

A. Burner cap
B. Burner base

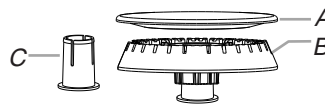

Medium Burner

A. Burner cap
B. Burner base
C. Choke (for use with medium burner, LP gas only)

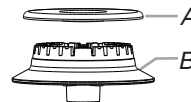

Small Burner

A. Burner cap
B. Burner base

4. Apply masking tape to the end of a 7 mm nut driver to help hold the gas orifice spud in the nut driver while changing it. Insert nut driver into the gas opening and press down onto the gas orifice spud and remove by turning the gas orifice spud counterclockwise and lifting out. Set gas orifice spud aside.
5. Replace with correct LP gas orifice spud. See the "LP Gas Orifice Spud/Hood Chart."

Use the following chart to find the exact orifice spud placement.

Fully insert choke into bottom of medium burner base. Choke should snap into place.

LP Gas Orifice Spud/Hood Chart

Burner Rating	Color	Size	Burner Style
3,000 BTU	Blue	0.55 mm	Small burners
11,000 BTU	Yellow	0.97 mm	Medium burners
14,000 BTU	Red/ Green	1.05 mm	Large burner - main
	Green	0.35 mm	Large burner - simmer
14,500 BTU	Black	1.18 mm	Grill burner

Burner orifice spud

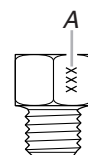

A. Size stamp or color

Grill orifice hood

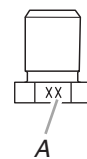

A. Size stamp

6. Place Natural gas orifice spuds in plastic parts bag for future use and keep with package containing literature.

- Replace the burner base.
- Replace burner cap.
- Repeat steps 2 through 8 for the remaining burners.

To Convert Grill Burner (on some models)

- Remove grill grate, wave plate, flame spreader and burner assembly. See "Install Grill Grease Trays" section for removal instructions. Set parts aside.
- Use a ½" deep-well socket to remove the Natural gas orifice hood. Replace with correct grill LP gas orifice hood. See "LP Gas Orifice Spud/Hood Chart."

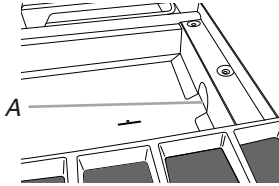

A. Grill orifice hood location

- Turn LP gas orifice hood down tightly onto orifice base.
- Place Natural gas orifice hoods in plastic parts bag for future use and keep with package containing literature.
- Before replacing the burner assembly, loosen the screw at the front of the burner and rotate the shutter so that the opening is ⅝" (8.0 mm) wide.

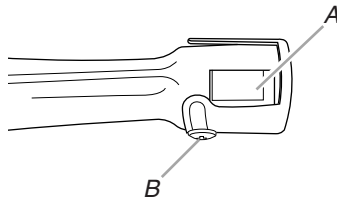

A. Shutter opening
B. Screw

- Reinstall the burner assembly, flame spreader, wave plate, and grill grate. See "Install Grill Grease Trays" section for installation instructions.
- Open shutoff valve in the gas supply line. The valve is open when the handle is parallel to the gas pipe.
REMEMBER: Once you have completed converting the grill, test the range for leaks by brushing on an approved noncorrosive leak-detection solution. Bubbles will show, indicating a leak. Correct any leaks found.
- Plug in range or reconnect power.

Complete Installation

- Refer to the "Make Gas Connection" section for properly connecting the range to the gas supply.
- Refer to the "Electronic Ignition System" section for proper burner ignition, operation, and burner flame adjustments.
IMPORTANT: You may have to adjust the "LO" setting for each cooktop burner.

Checking for proper cooktop burner flame is very important. The small inner cone should have a very distinct blue flame ¼" (0.64 cm) to ½" (1.3 cm) long. The outer cone is not as distinct as the inner cone. LP gas flames have a slightly yellow tip.

- Refer to "Complete Installation" in the "Installation Instructions" section of this manual to complete this procedure.

Natural Gas Conversion

⚠ WARNING

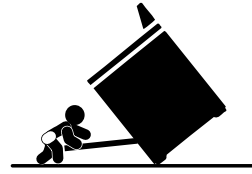

Tip Over Hazard

A child or adult can tip the range and be killed.

Install anti-tip bracket to floor or wall per installation instructions.

Slide range back so rear range foot is engaged in the slot of the anti-tip bracket.

Re-engage anti-tip bracket if range is moved.

Do not operate range without anti-tip bracket installed and engaged.

Failure to follow these instructions can result in death or serious burns to children and adults.

- Turn manual shutoff valve to the closed position.

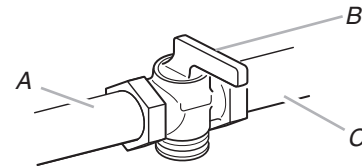

A. To range
B. Shutoff valve (closed position)
C. Gas supply line

- Unplug range or disconnect power.

To Convert Gas Pressure Regulator

- Remove the access cap by using a wrench, turning the access cap counterclockwise.
- Remove spring retainer from the cap by pushing against the flat side of the spring retainer. Look at the spring retainer to locate the "LP" or "NAT" position. Turn over the spring retainer so the "NAT" is showing on the bottom. Snap the spring retainer back into the cap. Reinstall the cap onto the regulator.

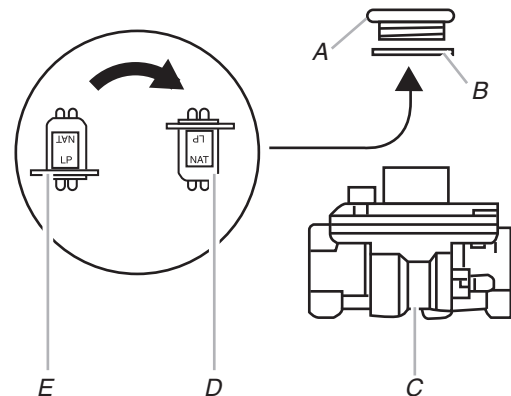

A. Access cap
B. Gasket
C. Gas pressure regulator
D. NAT position
E. LP position

- Test the gas pressure regulator and gas supply line.

The regulator must be checked at a minimum 1" (2.5 cm) water column above the set pressure. The inlet pressure to the regulator should be as follows for operation and checking the regulator setting:

Natural Gas:

Minimum pressure 6" (15.2 cm) WCP
 Maximum pressure 14" (35.6 cm) WCP

Gas Supply Pressure Testing

Gas supply pressure for testing regulator must be at least 1" water column pressure above the manifold pressure shown on the model/serial rating plate.

Line pressure testing above ½ psi gauge (14" WCP)

The range and its individual shutoff valve must be disconnected from the gas supply piping system during any pressure testing of that system at test pressures in excess of ½ psi (3.5 kPa).

Line pressure testing at ½ psi gauge (14" WCP) or lower

The range must be isolated from the gas supply piping system by closing its individual manual shutoff valve during any pressure testing of the gas supply piping system at test pressures equal to or less than ½ psi (3.5 kPa).

To Convert Surface Burners

- If the burner grates are installed, remove them.
- Remove burner cap.
- Remove the burner base.

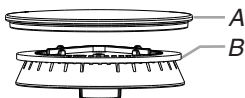

Large Dual Burner

A. Burner cap
 B. Burner base

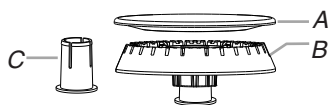

Medium Burner

A. Burner cap
 B. Burner base
 C. Choke (for use with medium burner, LP gas only)

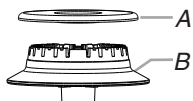

Small Burner

A. Burner cap
 B. Burner base

- Apply masking tape to the end of a 7 mm nut driver to help hold the gas orifice spud in the nut driver while changing it. Insert nut driver into the gas opening and press down onto the gas orifice spud and remove by turning the gas orifice spud counterclockwise and lifting out. Set gas orifice spud aside.

- Replace with correct Natural gas orifice spud. See the "Natural Gas Orifice Spud/Hood Chart."

Use the following chart to find the exact orifice spud placement.

Remove choke from medium burner base.

Natural Gas Orifice Spud/Hood Chart

Burner Rating	Size	Burner Style
5,000 BTU	1.01 mm	Small burners
15,000 BTU	1.75 mm	Medium burners
20,000 BTU	2.10 mm 0.52 mm	Large burner - main Large burner - simmer
18,000 BTU	1.93 mm	Grill burner

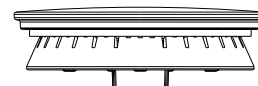
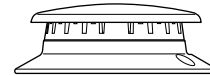

Burner orifice spud

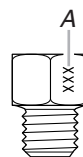

A. Size stamp

Grill orifice hood

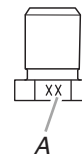

A. Size stamp

- Place LP gas orifice spuds in plastic parts bag for future use and keep with package containing literature.
- Replace the burner base.
- Replace burner cap.
- Repeat steps 2 through 8 for the remaining burners.

To Convert Grill Burner (on some models)

- Remove grill grate, wave plate, flame spreader and burner assembly. See "Install Grill Grease Trays" section for removal instructions. Set parts aside.
- Use a ½" deep-well socket and remove the LP gas orifice hood. Replace with correct grill Natural gas orifice hood. See "Natural Gas Orifice Spud/Hood Chart."

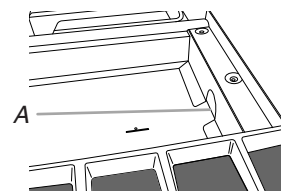

A. Grill orifice hood location

- Turn Natural gas orifice hood down tightly onto orifice base.
- Place LP gas orifice hoods in plastic parts bag for future use and keep with package containing literature.

5. Before replacing the burner assembly, loosen the screw at the front of the burner and rotate the shutter so that the opening is $\frac{3}{8}$ " (9.0 mm) wide.

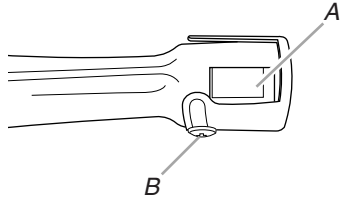

A. Shutter opening
B. Screw

6. Reinstall the burner assembly, flame spreader, wave plate, and grill grate. See "Install Grill Grease Trays" section for installation instructions.
7. Open shutoff valve in the gas supply line. The valve is open when the handle is parallel to the gas pipe.

REMEMBER: Once you have completed converting the grill, test the range for leaks by brushing on an approved noncorrosive leak-detection solution. Bubbles will show, indicating a leak. Correct any leaks found.

8. Plug in range or reconnect power.

Complete Installation

1. Refer to the "Make Gas Connection" section for properly connecting the range to the gas supply.
2. Refer to the "Electronic Ignition System" section for proper burner ignition, operation, and burner flame adjustments.

IMPORTANT: You may have to adjust the "LO" setting for each cooktop burner.

Checking for proper cooktop burner flame is very important. The small inner cone should have a very distinct blue flame $\frac{1}{4}$ " (0.64 cm) to $\frac{1}{2}$ " (1.3 cm) long. The outer cone is not as distinct as the inner cone. LP gas flames have a slightly yellow tip.

3. Refer to "Complete Installation" in the "Installation Instructions" section of this manual to complete this procedure.

Strip Circuits

The following individual circuits are for use in diagnoses, and are shown in the ON position. Do not continue with the diagnosis of the appliance if a fuse is blown, a circuit breaker is tripped, or if there is less than a 240 +10%/-15% volt power supply at the wall outlet.

Griddle 240V Control Wiring Diagram To Cooktop Stand-Alone and Freestanding

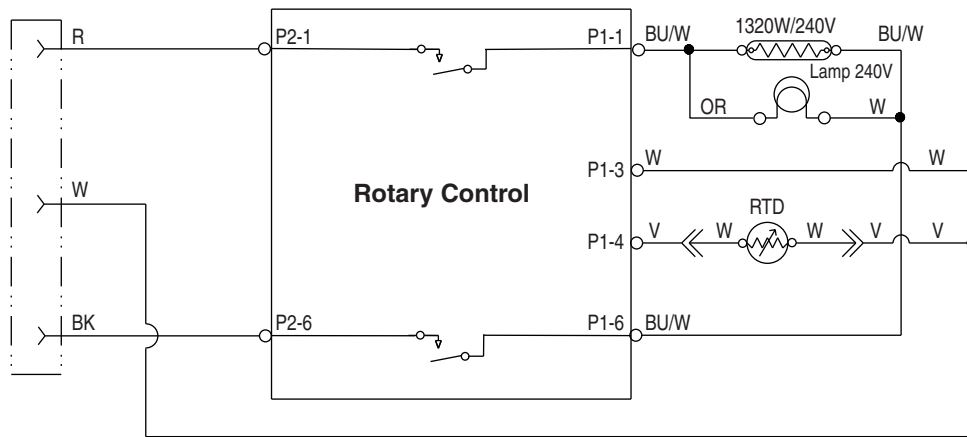

Grill Reignition Wiring Diagram To Cooktop Stand-Alone and Freestanding

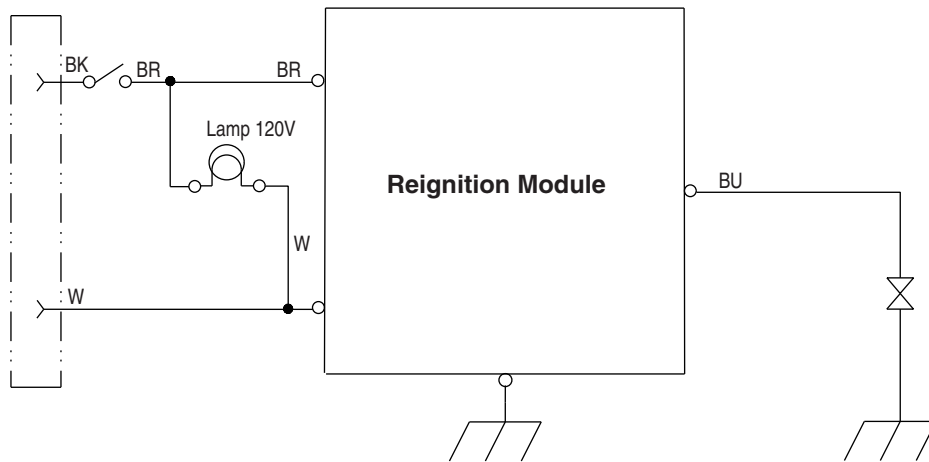

Wiring Diagrams

Caution: Label all wires prior to disconnection when servicing controls. Wiring errors can cause improper and dangerous operation. Verify proper operation after servicing.

Cooktop Schematics

4 Burner Cooktop

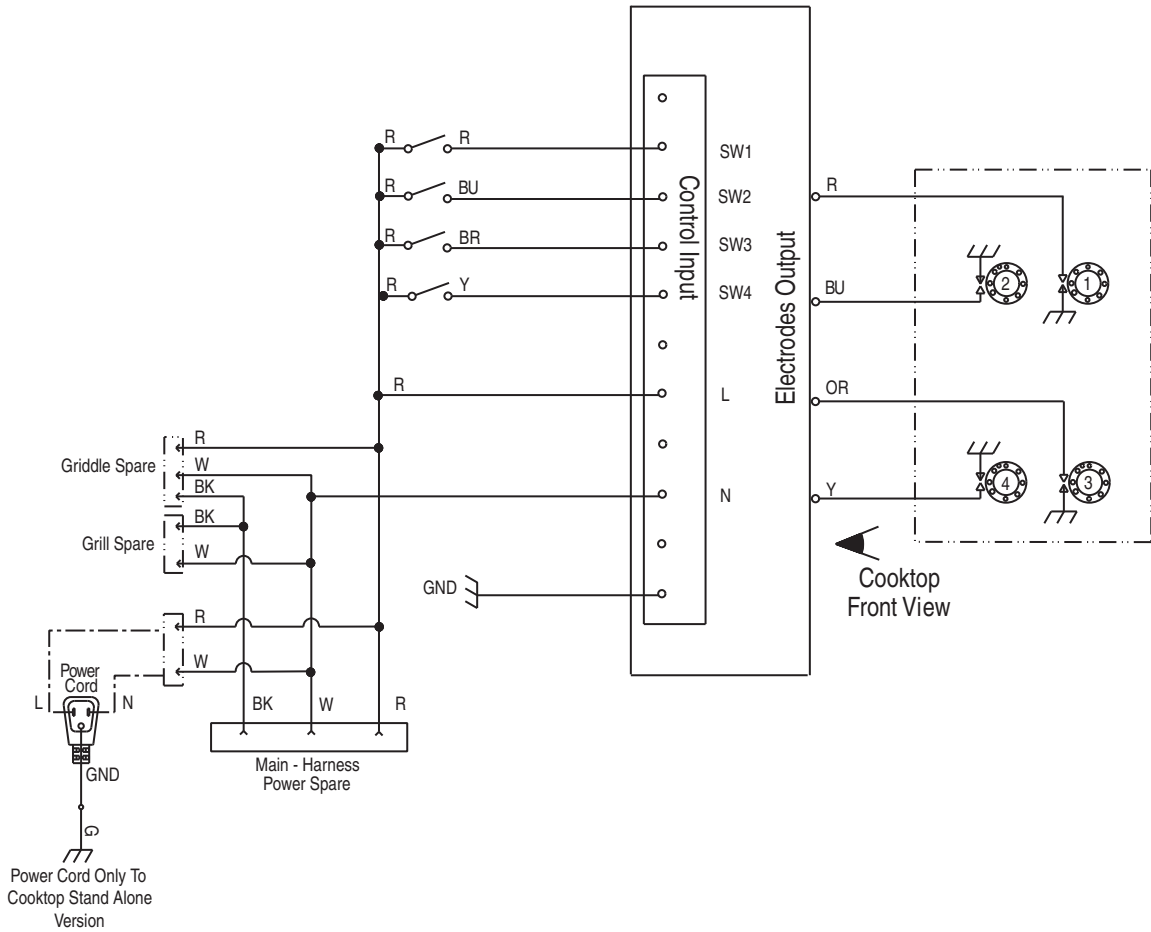

6 Burner Cooktop

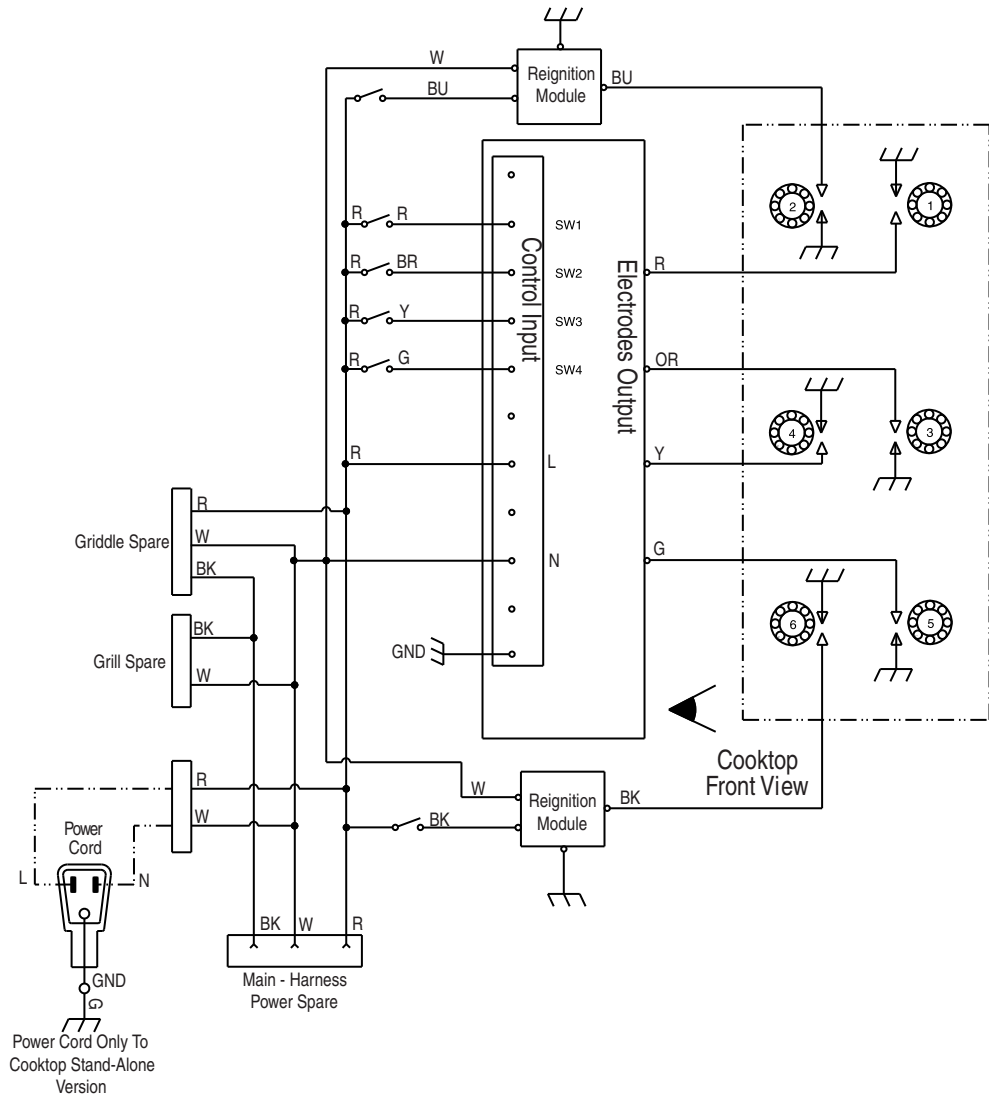

30"/36" (76.2 cm/91.4 cm) Oven Schematic for KDRS and YKDRS Models

NOTES:

- End of line tester is for manufacturing purpose only.
- Circuit shown in STANDBY/OFF mode with oven door closed.
- Dots indicate connections or splices.

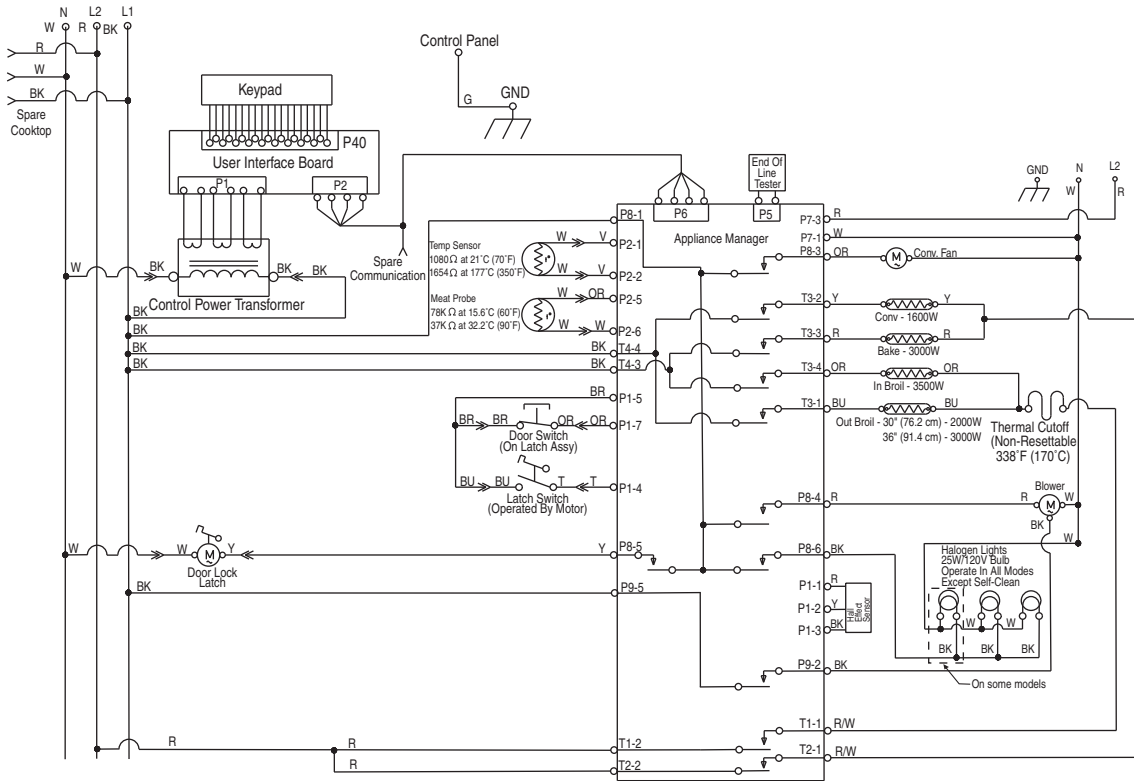

LEGEND

Ground (Chassis)	Plug With Female Connector	Receptacle With Male Connector	Light	AC Drive Motor	Relay Coil	Relay Contact	Heating Element	Enclosed Thermistor	Operated By Door	Thermal Cutoff (Non-Resettable)	Thermostat

48" (121.9 cm) Oven Schematic for KDRS Models

NOTES:

- End of line tester is for manufacturing purpose only.
- Circuit shown in STANDBY/OFF mode with oven door closed.
- Dots indicate connections or splices.

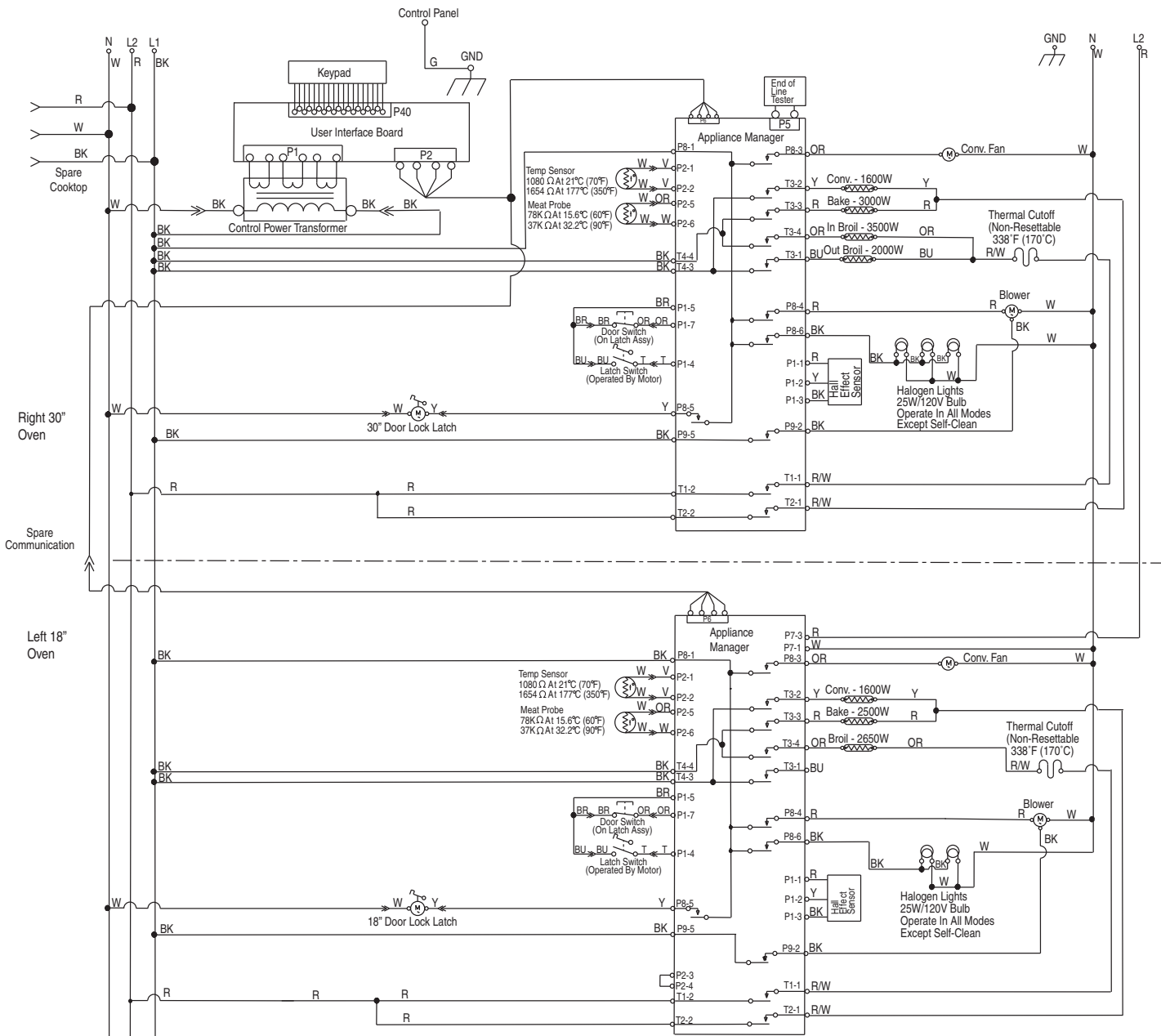

LEGEND

Ground (Chassis)	Plug With Female Connector	Receptacle With Male Connector	Light	AC Drive Motor	Relay Coil	Relay Contact	Heating Element	Enclosed Thermistor	Operated By Door	Thermal Cutoff (Non-Resettable)	Thermostat

30"/36" (76.2 cm/91.4 cm) Oven Schematic for KDRU and YKDRU Models

NOTES:

- End of line tester is for manufacturing purpose only.
- Circuit shown in STANDBY/OFF mode with oven door closed.
- Dots indicate connections or splices.

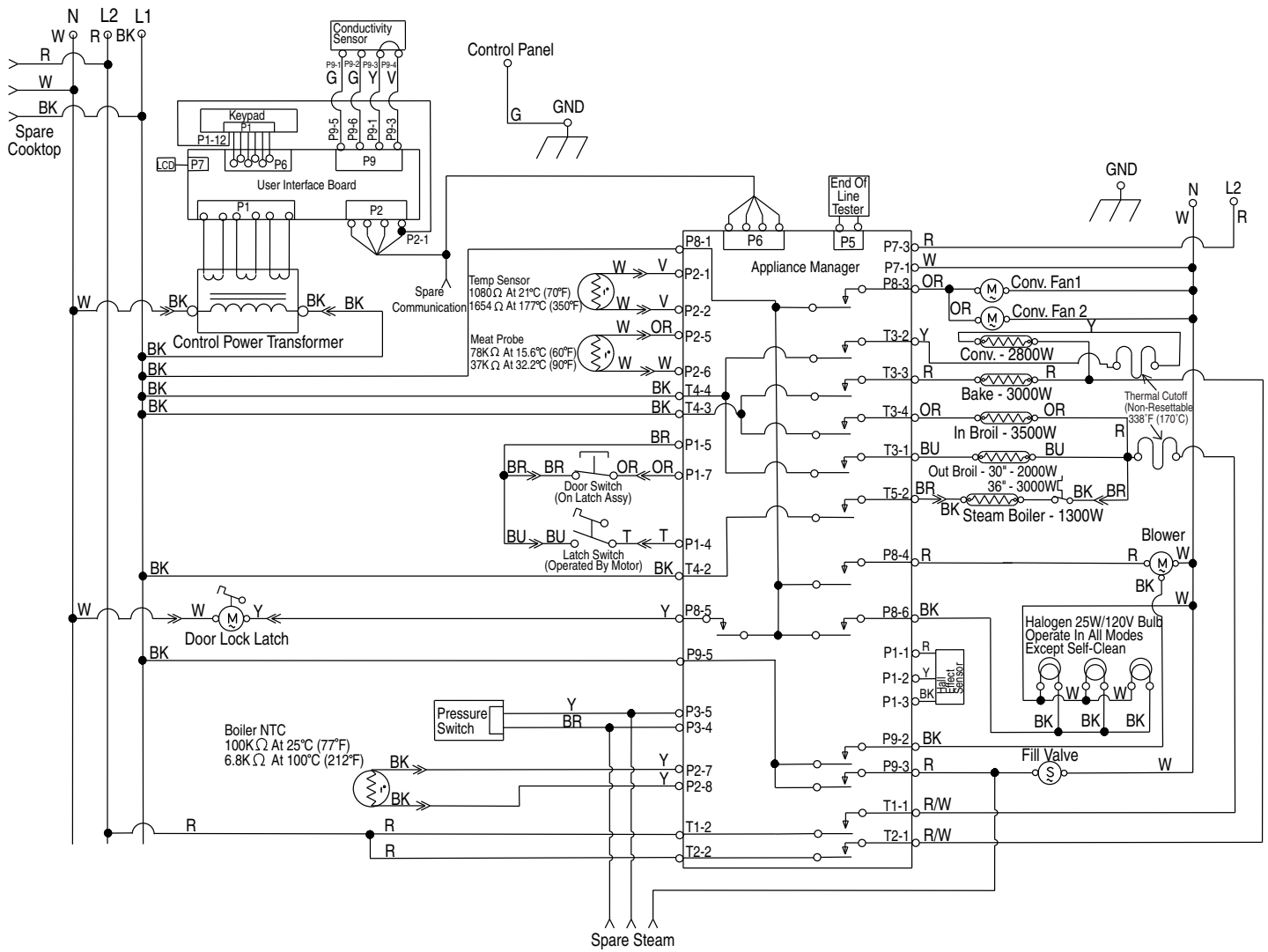

LEGEND

Ground (Chassis)	Plug With Female Connector	Receptacle With Male Connector	Light	AC Drive Motor	Relay Coil	Relay Contact	Heating Element	Enclosed Thermistor	Operated By Door	Thermal Cutoff (Non-Resettable)	Thermostat	Fill Valve

48" (121.9 cm) Oven Schematic for KDRU Models

NOTES:

- End of line tester is for manufacturing purpose only.
- Circuit shown in STANDBY/OFF mode with oven door closed.
- Dots indicate connections or splices.

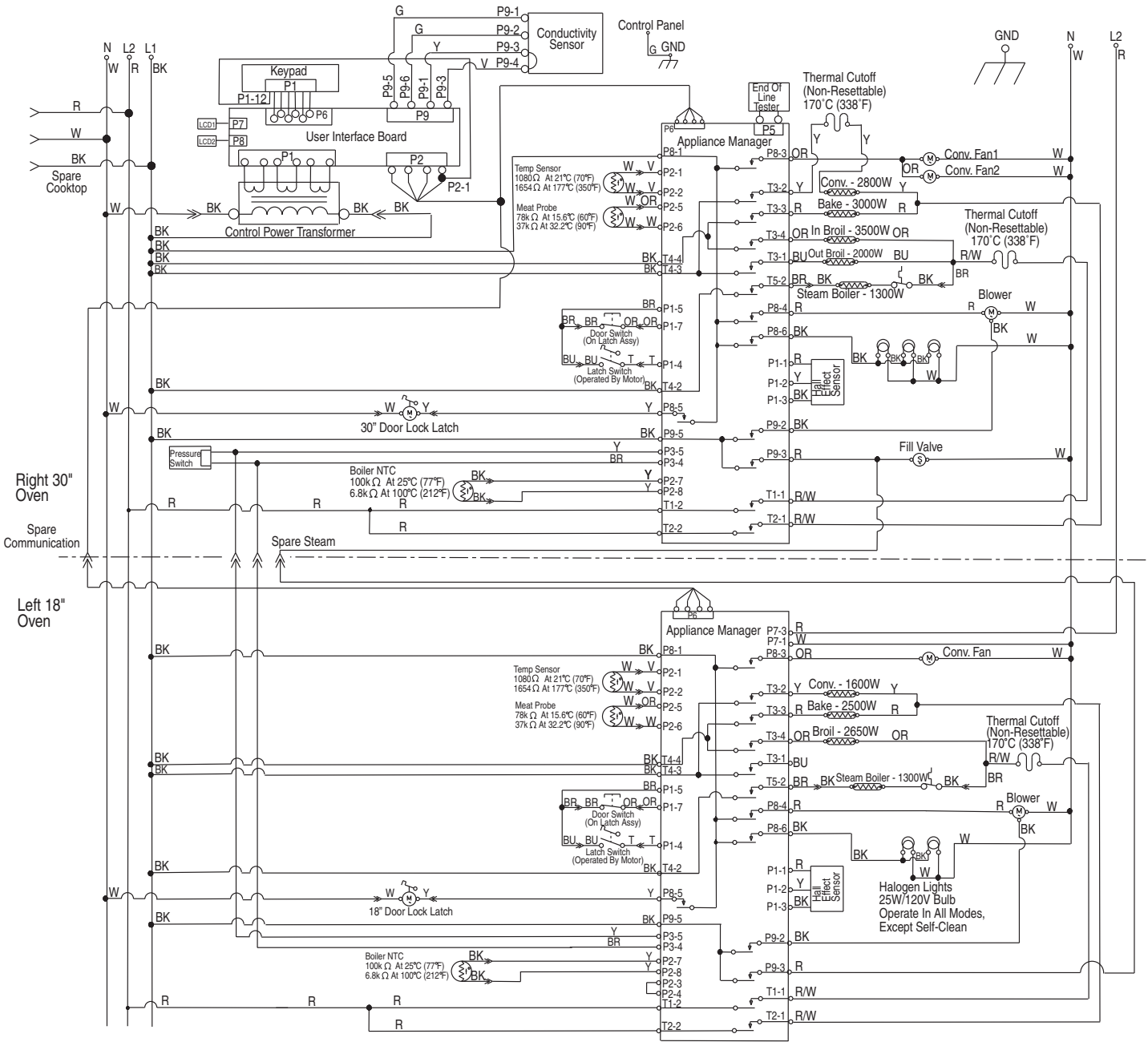

LEGEND

Ground (Chassis)	Plug With Female Connector	Receptacle With Male Connector	Light	AC Drive Motor	Relay Coil	Relay Contact	Heating Element	Enclosed Thermistor	Operated By Door	Thermal Cutoff (Non-Resettable)	Thermostat	Fill Valve

