

KitchenAid®

30" AND 36" (76.2 CM AND 91.4 CM) GAS DOWNDRAFT COOKTOP

Use and Care Guide

For questions about features, operation/performance, parts, accessories or service, call: **1-800-422-1230**
or visit our website at www.kitchenaid.com

In Canada, call **1-800-807-6777** or visit our website at www.kitchenaid.ca.

TABLE DE CUISSON À GAZ À EXTRACTION PAR LE BAS DE 30" (76,2 CM) OU DE 36" (91,4 CM)

Guide d'utilisation et d'entretien

Pour des questions à propos des caractéristiques, du fonctionnement/rendement, des pièces, des accessoires ou du service,
composez le : **1 800 422-1230** ou visiter notre site internet sur www.kitchenaid.com.

Au Canada, pour assistance, installation ou service, composer le **1 800 807-6777** ou visiter notre site Web au www.kitchenaid.ca.



TABLE OF CONTENTS

COOKTOP SAFETY	3
PARTS AND FEATURES	5
COOKTOP USE	6
Cooktop Controls.....	6
Sealed Surface Burners	6
Melt Cap.....	7
Surface Grates	7
Downdraft Ventilation System.....	7
Home Canning	8
Cookware	8
COOKTOP CARE	8
General Cleaning.....	8
TROUBLESHOOTING	10
ASSISTANCE OR SERVICE	11
In the U.S.A.	11
Accessories	11
In Canada.....	11
WARRANTY	12

TABLE DES MATIÈRES

SÉCURITÉ DE LA TABLE DE CUISSON	13
PIÈCES ET CARACTÉRISTIQUES	15
UTILISATION DE LA TABLE DE CUISSON	16
Commandes de la table de cuisson	16
Brûleurs de surface scellés.....	17
Chapeau pour faire fondre	18
Grilles de surface	18
Système de ventilation avec aspiration par le bas	18
Préparation de conserves à la maison	19
Ustensiles de cuisson	19
ENTRETIEN DE LA TABLE DE CUISSON	19
Nettoyage général.....	19
DÉPANNAGE	21
ASSISTANCE OU SERVICE	22
Aux É.-U.	22
Accessoires	22
Au Canada.....	22
GARANTIE	23

COOKTOP SAFETY

Your safety and the safety of others are very important.

We have provided many important safety messages in this manual and on your appliance. Always read and obey all safety messages.



This is the safety alert symbol.

This symbol alerts you to potential hazards that can kill or hurt you and others.

All safety messages will follow the safety alert symbol and either the word “DANGER” or “WARNING.”

These words mean:

⚠ DANGER

You can be killed or seriously injured if you don't immediately follow instructions.

⚠ WARNING

You can be killed or seriously injured if you don't follow instructions.

All safety messages will tell you what the potential hazard is, tell you how to reduce the chance of injury, and tell you what can happen if the instructions are not followed.

WARNING: If the information in these instructions is not followed exactly, a fire or explosion may result causing property damage, personal injury or death.

- Do not store or use gasoline or other flammable vapors and liquids in the vicinity of this or any other appliance.
- **WHAT TO DO IF YOU SMELL GAS:**
 - Do not try to light any appliance.
 - Do not touch any electrical switch.
 - Do not use any phone in your building.
 - Immediately call your gas supplier from a neighbor's phone. Follow the gas supplier's instructions.
 - If you cannot reach your gas supplier, call the fire department.
- Installation and service must be performed by a qualified installer, service agency or the gas supplier.

WARNING: Gas leaks cannot always be detected by smell.

Gas suppliers recommend that you use a gas detector approved by UL or CSA.

For more information, contact your gas supplier.

If a gas leak is detected, follow the “What to do if you smell gas” instructions.

IMPORTANT SAFETY INSTRUCTIONS

WARNING: To reduce the risk of fire, electrical shock, injury to persons, or damage when using the cooktop, follow basic precautions, including the following:

- **WARNING:** NEVER use this appliance as a space heater to heat or warm the room. Doing so may result in carbon monoxide poisoning and overheating of the cooktop.
- **CAUTION:** Do not store items of interest to children in cabinets above the cooktop – children climbing on the cooktop to reach items could be seriously injured.
- Proper Installation – The cooktop, when installed, must be electrically grounded in accordance with local codes or, in the absence of local codes, with the *National Electrical Code, ANSI/NFPA70 or the Canadian Electrical Code, Part 1*. Be sure the cooktop is properly installed and grounded by a qualified technician.
- This cooktop is equipped with a three-prong grounding plug for your protection against shock hazard and should be plugged directly into a properly grounded receptacle. Do not cut or remove the grounding prong from this plug.
- Disconnect the electrical supply before servicing the cooktop.
- Injuries may result from the misuse of the cooktop such as stepping, leaning, or sitting on the top surface.
- Maintenance – Keep cooktop area clear and free from combustible materials, gasoline, and other flammable vapors and liquids.
- Storage on the cooktop – Flammable materials should not be stored on or near surface units.
- Top burner flame size should be adjusted so it does not extend beyond the edge of the cooking utensil.

SAVE THESE INSTRUCTIONS

State of California Proposition 65 Warnings:

WARNING: This product contains one or more chemicals known to the State of California to cause cancer.

WARNING: This product contains one or more chemicals known to the State of California to cause birth defects or other reproductive harm.

PARTS AND FEATURES

This manual covers different models. The cooktop you have purchased may have some or all of the items listed.

30" (76.2 cm) Control Panel

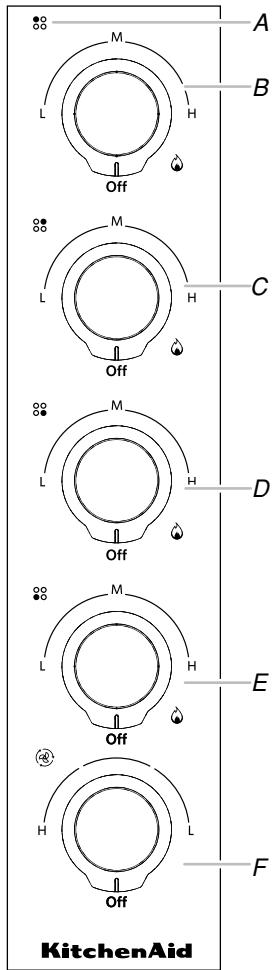

- A. Surface burner locator
- B. Left rear control knob
- C. Right rear control knob
- D. Right front control knob
- E. Left front control knob
- F. 3-speed vent fan control knob

KitchenAid

36" (91.4 cm) Control Panel

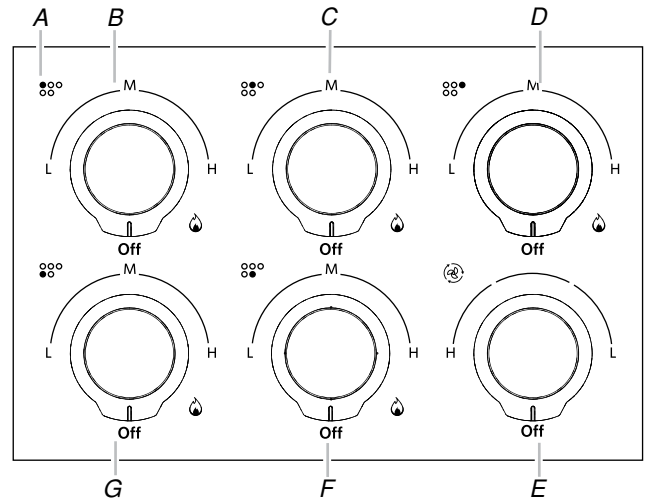

- A. Surface burner locator
- B. Left rear control knob
- C. Center rear control knob
- D. Right rear control knob
- E. 3-speed fan control knob
- F. Center front control knob
- G. Left front control knob

36" (91.4 cm) Cooktop

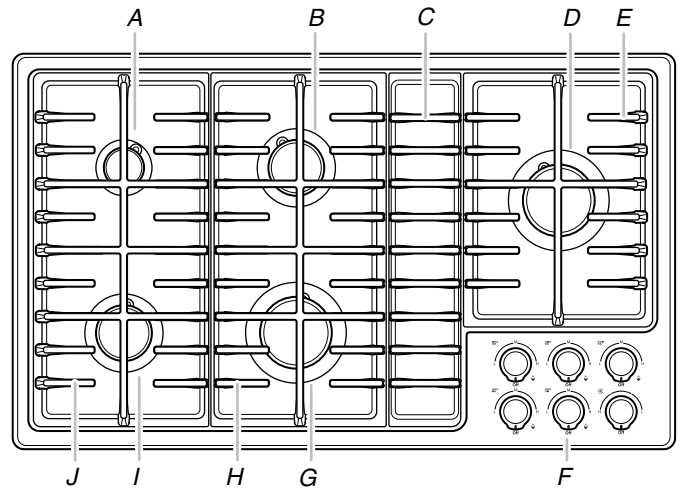

- A. Left rear 5,000 Btu/h burner
- B. Center rear 12,500 Btu/h burner
- C. Downdraft vent grille
- D. Right rear 17,000 Btu/h burner
- E. Right side grate
- F. Control panel
- G. Center front 15,000 Btu/h burner
- H. Center grate
- I. Left front 10,000 Btu/h burner
- J. Left side grate

30" (76.2 cm) Cooktop

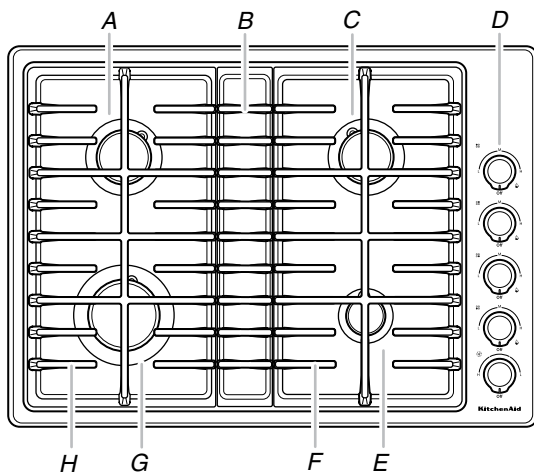

- A. Left rear 5,000 Btu/h burner
- B. Downdraft vent grille
- C. Right rear 15,000 Btu/h burner
- D. Control panel
- E. Right front 10,000 Btu/h burner
- F. Right side grate
- G. Left front 17,000 Btu/h burner
- H. Left side grate

COOKTOP USE

Cooktop Controls

WARNING



Fire Hazard

Do not let the burner flame extend beyond the edge of the pan.

Turn off all controls when not cooking.

Failure to follow these instructions can result in death or fire.

Electric igniters automatically light the surface burners when control knobs are turned to  (Ignite) and will automatically reignite if the flame is extinguished.

NOTE: All igniters will spark when lighting; however, only the selected burner will ignite.

If a cross draft is present, the flame may be affected and some sparking may occur. This is normal.

Before setting a control knob, place filled cookware on the grate. Do not operate a burner using empty cookware or without cookware on the grate.

Lighting the Burners

IMPORTANT: All burners will click/spark when a knob is pushed in. A burner will light only if the knob is pushed in and then turned counterclockwise to the Ignite position.

To light the burners:

1. Push in the knob.
2. Turn the knob counterclockwise to the Ignite position. Wait until you see a flame.
3. Turn the knob to anywhere between H and L to the desired setting.

Setting	Recommended Use
H (High)	<ul style="list-style-type: none"> ■ Start food cooking. ■ Bring liquid to a boil. ■ Hold a rapid boil. ■ Quickly brown or sear food. ■ Fry chicken.
M (Medium)	<ul style="list-style-type: none"> ■ Maintain a slow boil. ■ Fry or sauté foods. ■ Cook soups, sauces, and gravies. ■ Stew or steam food.
L (Low)	<ul style="list-style-type: none"> ■ Simmer. ■ Keep food warm.

REMEMBER: When cooktop is in use, the entire cooktop area may become hot.

Power failure

In case of prolonged power failure, the surface burners can be lit manually. Hold a lit match near a burner and turn knob counterclockwise to the Ignite position. After burner lights, turn knob to setting. The vent fan will not work.

NOTE: The downdraft vent will not operate during a power failure.

Flame Sensing Reignition

Your cooktop has sealed gas burners with Flame Sensing Reignition. If any burner flame should go out, the system will automatically spark to reignite the burner (all igniters will spark when any flame is extinguished; however, only the selected burner will reignite). If intermittent sparking occurs, increase flame (rotate knob clockwise) until clicking (spark) sound ceases.

Smart Port Burner System

This cooktop is equipped with a Smart Port Burner System. The Smart Port Burner System produces a small flame directly under each grate finger and a larger flame between each grate finger. The visual difference between the ports will be noticeable when the burner is used or when adjustments are made to the flame length.

Sealed Surface Burners

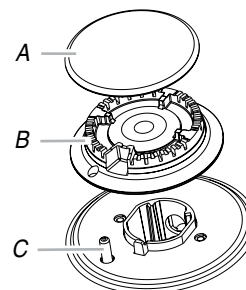

- A. Cap
- B. Spreader
- C. Electrode

IMPORTANT: Do not obstruct the flow of combustion and ventilation air around the burner grate edges.

Burner cap: Always keep the burner cap in place when using a surface burner. A clean burner cap will help avoid poor ignition and uneven flames. Always clean the burner cap after a spillover and routinely remove and clean the caps according to the "General Cleaning" section.

NOTE: Each round burner base is marked with a letter indicating the burner size. Place the burner caps on the appropriate burner bases.

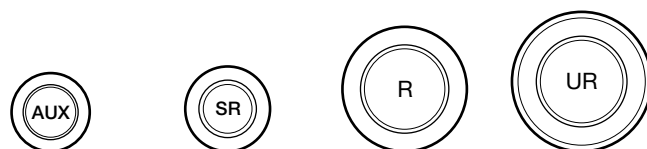

- Small (AUX)
- Medium (SR)
- Large (R)
- Extra large (UR)

Alignment: Be sure to align the gas tube opening in the burner base with the orifice holder on the cooktop and the igniter electrode with the notch in the burner base.

NOTE: Each round burner base is marked with a letter indicating the burner size. Place the burner caps on the appropriate burner bases.

Gas tube opening: Gas must flow freely throughout the gas tube opening for the burner to light properly. Keep this area free of soil and do not allow spills, food, cleaning agents, or any other material to enter the gas tube opening. Keep spillovers out of the gas tube by always using a burner cap.

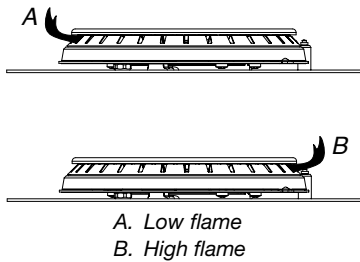

Burner ports: Check burner flames occasionally for proper size and shape as shown in the previous illustration. A good flame is blue in color, not yellow. Keep this area free of soil and do not allow spills, food, cleaning agents, or any other material to enter the burner ports.

To Clean:

IMPORTANT: Before cleaning, make sure all controls are OFF and the oven and cooktop are cool. Do not use oven cleaners, bleach, or rust removers.

1. Remove the burner cap from the burner base and clean according to the "General Cleaning" section.
2. Clean the gas tube opening with a damp cloth.
3. Clean clogged burner ports with a straight pin as shown. Do not enlarge or distort the port. Do not use a wooden toothpick. If the burner needs to be adjusted, contact a trained repair specialist.

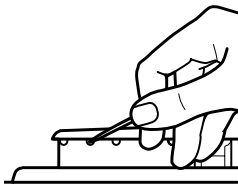

4. Each round burner cap is marked with letters indicating the burner size. Replace the burner cap, making sure the alignment pins are properly aligned with the burner cap. Place the burner caps on the appropriate burner bases.

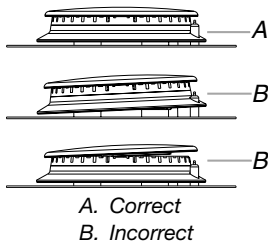

IMPORTANT: The bottom of the small and medium caps are different. Do not put the wrong size burner cap on the burner base.

5. Turn on the burner. If the burner does not light, verify the burner cap placement and check cap and burner base alignment. If the burner still does not light, do not service the sealed burner yourself. Contact a trained repair specialist.

Melt Cap

For melting chocolate or butter or an even more delicate simmer, the melt cap can be used in place of the standard burner cap. The melt cap should only be used on the small burner (right rear). Remove the small burner cap and replace it with the larger melt cap for delicate simmering. For less delicate simmering, use the small cap.

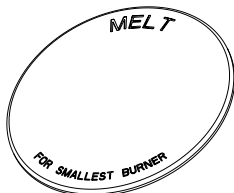

Surface Grates

The grates must be properly positioned before cooking. In the proper position, the grates should be flush and level. Improper installation of the grates may result in chipping or scratching of the cooktop.

To ensure proper positioning, align bumpers on grate bottom with the indentations in the cooktop. See cooktop illustrations in the "Parts and Features" section for proper grate positioning.

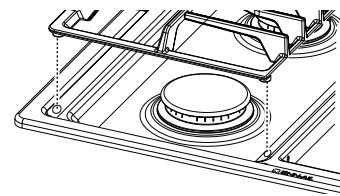

Although the burner grates are durable, they will gradually lose their shine and/or discolor due to the high temperatures of the gas flame.

Downdraft Ventilation System

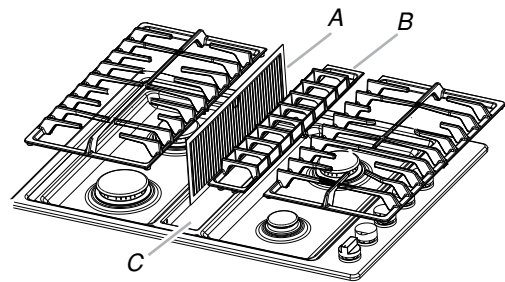

The built-in downdraft ventilation system removes cooking vapors, odors, and smoke from foods prepared on the cooktop.

IMPORTANT: For optimal performance, operate downdraft ventilation system with the filter properly installed.

To avoid the buildup of grease, the filter should be cleaned often.

The filter should always be placed at an angle. As you face the front of the cooktop, the top of the filter should rest against the right side of the vent opening. The bottom of the filter should rest against the left side of the vent chamber at the bottom.

If the filter is flat against the fan wall, ventilation effectiveness will be reduced.

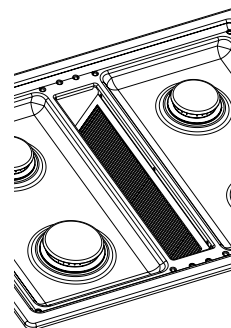

To Use:

Turn vent knob to desired speed: H, L, or to the midpoint between H and L for Medium. Turn vent fan knob to OFF when finished cooking or when the cooktop is not in use.

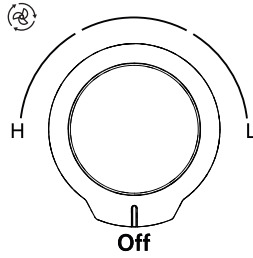

Home Canning

When canning for long periods, alternate the use of surface burners between batches. This allows time for the most recently used areas to cool.

- Center the canner on the grate above the burner.
- Do not place canner on 2 surface burners at the same time.
- For more information, contact your local agricultural department. Companies that manufacture home canning products can also offer assistance.

Cookware

IMPORTANT: Do not leave empty cookware on a hot surface cooking area, element, or surface burner.

Ideal cookware should have a flat bottom, straight sides, and a well-fitting lid and the material should be of medium-to-heavy thickness.

Rough finishes may scratch the cooktop or grates. Aluminum and copper may be used as a core or base in cookware. However, when used as a base, they can leave permanent marks on the cooktop or grates.

Cookware material is a factor in how quickly and evenly heat is transferred, which affects cooking results. A nonstick finish has the same characteristics as its base material.

For example, aluminum cookware with a nonstick finish will take on the properties of aluminum.

Use the following chart as a guide for cookware material characteristics.

Cookware	Characteristics
Aluminum	<ul style="list-style-type: none">■ Heats quickly and evenly.■ Suitable for all types of cooking■ Medium or heavy thickness is best for most cooking tasks.
Cast iron	<ul style="list-style-type: none">■ Heats slowly and evenly.■ Good for browning and frying■ Maintains heat for slow cooking.
Ceramic or ceramic glass	<ul style="list-style-type: none">■ Follow manufacturer's instructions.■ Heats slowly but unevenly.■ Ideal results on low to medium heat settings.
Copper	<ul style="list-style-type: none">■ Heats very quickly and evenly.
Earthenware	<ul style="list-style-type: none">■ Follow manufacturer's instructions.■ Use on low heat settings.
Porcelain enamel-on-steel or cast iron	<ul style="list-style-type: none">■ See stainless steel or cast iron.
Stainless steel	<ul style="list-style-type: none">■ Heats quickly but unevenly.■ A core or base of aluminum or copper on stainless steel provides even heating.

COOKTOP CARE

General Cleaning

IMPORTANT: Before cleaning, make sure all controls are OFF and the cooktop is cool. Always follow label instructions on cleaning products.

Soap, water, and a soft cloth or sponge are suggested first unless otherwise noted.

EXTERIOR PORCELAIN ENAMEL SURFACES (on some models)

Food spills containing acids, such as vinegar and tomato, should be cleaned as soon as the entire appliance is cool. These spills may affect the finish.

Cleaning Method:

- Glass cleaner, mild liquid cleaner, or nonabrasive scrubbing pad.
- Affresh® Kitchen and Appliance Cleaner Part Number W10355010 (not included):
See the "Assistance or Service" section to order.

STAINLESS STEEL COOKTOP

To avoid damage to stainless steel surfaces, do not use soap-filled scouring pads, abrasive cleaners, cooktop cleaner, steelwool pads, gritty washcloths, or abrasive paper towels.

For best results, use a soft cloth or non-scratch sponge.

Rub in direction of grain to avoid damaging.

Cleaning Method:

- Affresh® Stainless Steel Cleaner Part Number W10355016 (not included):
See the "Assistance or Service" section to order.
- All-purpose cleaner:
Rinse with clean water and dry with soft, lint-free cloth.
- Vinegar for hard water spots

COOKTOP CONTROLS

To avoid damage to the cooktop controls, do not use steel wool, abrasive cleansers, or oven cleaner.

To avoid damage, do not soak knobs.

When replacing knobs, make sure knobs are in the OFF position.

On some models, do not remove seals under knobs.

Cleaning Method:

- Soap and water:
Pull knobs straight away from control panel to remove.

GRATES AND CAPS

Food spills containing acids, such as vinegar and tomato, should be cleaned as soon as the cooktop, grates, and caps are cool. These spills may affect the finish.

To avoid chipping, do not bang grates and caps against each other or hard surfaces such as cast iron cookware.

Do not reassemble caps on burners while wet.

Cleaning Method:

- Nonabrasive plastic scrubbing pad and mildly abrasive cleanser:
Clean as soon as cooktop, grates, and caps are cool.
- Dishwasher (grates only, not caps):
Use the most aggressive cycle.
- Gas Grate and Drip Pan Cleaner Part Number 31617 (not included):
See the "Assistance or Service" section to order.

SURFACE BURNERS AND ELECTRONIC IGNITER

Surface Burners

See the "Sealed Surface Burners" section.

Electronic Igniter

Cleaning Method:

- Clean the stainless steel igniter washer using a nonabrasive scouring pad. Clean ceramic post with a cotton swab.
- Affresh® Kitchen and Appliance Cleaner Part Number W10355010 (not included):
See the "Assistance or Service" section to order.

DOWNDRAFT VENTILATION SYSTEM

Vent Grate

Cleaning Method:

- Lift off the vent grate.

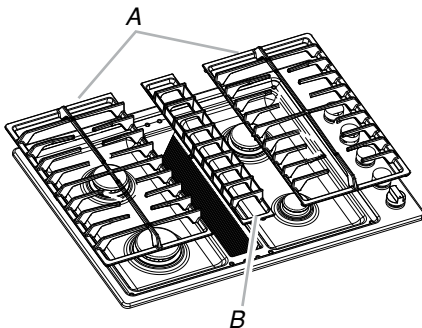

A. Burner grates
B. Vent grates

- Wipe clean or wash in sink:
Nonabrasive plastic scrubbing pad and mildly abrasive cleanser
- Dishwasher:
Use mild detergent.

Removable Grease Filter

The filter is a permanent type and should be cleaned when soiled.

Cleaning Method:

- Turn off the downdraft ventilation system before removing the filter.
- Remove burner grates, then vent grate and lift the filter out of the vent chamber.
- Clean the filter in the sink with warm water and detergent or in the top rack of the dishwasher.
- Replace the filter.

The filter should always be placed at an angle. As you face the front of the cooktop, the top of the filter should rest against the right side of the vent opening. The bottom of the filter should rest against the left side of the vent chamber at the bottom.

If the filter is flat against the fan wall, ventilation effectiveness will be reduced.

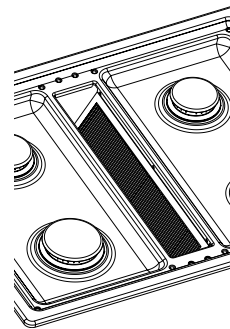

Ventilation Chamber

The ventilation chamber, which houses the filter, should be cleaned in the event of spills or when it becomes coated with a film of grease.

Cleaning Method:

- Mild household detergent or cleanser and paper towel, damp cloth, or sponge:
Apply detergent or cleanser to paper towel, damp cloth, or sponge, not directly to the ventilation chamber.

TROUBLESHOOTING

First try the solutions suggested here. If you need further assistance or more recommendations that may help you avoid a service call, refer to the warranty page in this manual, or visit <https://kitchenaid.custhelp.com>. In Canada, visit <http://www.kitchenaid.ca>.

Contact us by mail with any questions or concerns at the address below.

In the U.S.A.:

KitchenAid Brand Home Appliances
Customer eXperience Center
553 Benson Road
Benton Harbor, MI 49022-2692

In Canada:

KitchenAid Brand Home Appliances
Customer eXperience Centre
200 - 6750 Century Ave.
Mississauga, Ontario L5N 0B7

Please include a daytime phone number in your correspondence.

⚠ WARNING



Electrical Shock Hazard

Plug into a grounded 3 prong outlet.

Do not remove ground prong.

Do not use an adapter.

Do not use an extension cord.

Failure to follow these instructions can result in death, fire, or electrical shock.

Problem	Possible Causes and/or Solutions
Nothing will operate	<p>A household fuse has blown or a circuit breaker has tripped : Replace the fuse or reset the circuit breaker. If the problem continues, call an electrician.</p> <p>The power supply cord is unplugged : Plug into a grounded 3 prong outlet.</p>
Surface burners will not operate	<p>First time the surface burners have been used : Turn on any one of the surface burner knobs to release air from the gas lines.</p> <p>Control knob set incorrectly : Push in knob before turning to a setting.</p> <p>Burner ports are clogged : See the “Sealed Surface Burners” section.</p> <p>Burner caps and heads are positioned improperly: See the “Sealed Surface Burners” section.</p>
Surface burner flames are uneven, yellow, and/or noisy	<p>Burner ports are clogged : See the “Sealed Surface Burners” section.</p> <p>Burner caps and heads are positioned improperly : See the “Sealed Surface Burners” section.</p> <p>Propane gas is being used : The cooktop may have been converted improperly. Contact a service technician.</p>
Surface burner makes popping noises	<p>The burner is wet - Let it dry.</p>
Continuous sparking of igniter	<p>Cross draft is drawing the flame away from the igniter : This is normal when a cross draft is present.</p> <p>Power supply cord is improperly grounded/polarized : See the Installation Instructions.</p> <p>Burner caps and heads are positioned improperly : See the “Sealed Surface Burners” section.</p>
Excessive heat around cookware on cooktop	<p>Cookware is not the proper size : Use cookware about the same size as the surface cooking area, element, or surface burner. Cookware should not extend more than ½" (1.3 cm) outside the cooking area.</p>
Cooktop cooking results not what expected	<p>Proper cookware is not being used : See the “Cookware” section.</p> <p>Control knob is not set to the proper heat level : See the “Cooktop Controls” section.</p> <p>Cooktop is not level : Level the cooktop. See the Installation Instructions.</p>

ASSISTANCE OR SERVICE

If you need service

Please refer to the warranty page in this manual.

If you need replacement parts

If you need to order replacement parts, we recommend that you use only factory specified parts. These factory specified parts will fit right and work right because they are made with the same precision used to build every new KitchenAid® appliance.

To locate factory specified parts in your area, call us or your nearest KitchenAid designated service center.

In the U.S.A.

Call the KitchenAid Customer eXperience Center toll-free:
1-800-422-1230 or visit our website at **www.kitchenaid.com**.

Our consultants provide assistance with:

- Scheduling of service. KitchenAid® appliances designated service technicians are trained to fulfill the product warranty and provide after-warranty service anywhere in the United States.
- Features and specifications on our full line of appliances.
- Referrals to local KitchenAid® appliance dealers.
- Installation information.
- Use and maintenance procedures.
- Accessory and repair parts sales.
- Specialized customer assistance (Spanish speaking, hearing impaired, limited vision, etc.).

For further assistance:

If you need further assistance, you can write to KitchenAid with any questions or concerns at:

KitchenAid Brand Home Appliances
Customer eXperience Center
553 Benson Road
Benton Harbor, MI 49022-2692

Please include a daytime phone number in your correspondence.

In Canada

Call the KitchenAid Customer eXperience Center toll-free:
1-800-807-6777 or visit our website at **www.kitchenaid.ca**.

Our consultants provide assistance with:

- Scheduling of service. KitchenAid® appliances designated service technicians are trained to fulfill the product warranty and provide after-warranty service anywhere in Canada.
- Features and specifications on our full line of appliances.
- Referrals to local KitchenAid® appliance dealers.
- Use and maintenance procedures.
- Accessory and repair parts sales.

For further assistance:

If you need further assistance, you can write to KitchenAid with any questions or concerns at:

KitchenAid Brand Home Appliances
Customer eXperience Centre
200 - 6750 Century Ave.
Mississauga, ON L5N 0B7

Please include a daytime phone number in your correspondence.

ACCESSORIES

To order accessories, visit our website at **www.kitchenaid.com**.

Affresh® Stainless Steel Cleaner

(stainless steel models)
Order Part Number W10355016

Affresh® Kitchen and Appliance Cleaner

Order Part Number W10355010

KITCHENAID® COOKTOP LIMITED WARRANTY

ATTACH YOUR RECEIPT HERE. PROOF OF PURCHASE IS REQUIRED TO OBTAIN WARRANTY SERVICE.

Please have the following information available when you call the Customer eXperience Center:

- Name, address and telephone number
- Model number and serial number
- A clear, detailed description of the problem
- Proof of purchase including dealer or retailer name and address

IF YOU NEED SERVICE:

1. Before contacting us to arrange service, please determine whether your product requires repair. Some questions can be addressed without service. Please take a few minutes to review the Troubleshooting or Problem Solver section of the Use and Care Guide, or visit <http://kitchenaid.custhelp.com>.
2. All warranty service is provided exclusively by our authorized KitchenAid Service Providers. In the U.S. and Canada, direct all requests for warranty service to:

KitchenAid Customer eXperience Center

In the U.S.A., call 1-800-422-1230. In Canada, call 1-800-807-6777.

If outside the 50 United States or Canada, contact your authorized KitchenAid dealer to determine whether another warranty applies.

FIVE YEAR LIMITED WARRANTY

WHAT IS COVERED

FIRST YEAR LIMITED WARRANTY (PARTS AND LABOR)

For one year from the date of purchase, when this major appliance is installed, operated and maintained according to instructions attached to or furnished with the product, KitchenAid brand of Whirlpool Corporation or Whirlpool Canada, LP (hereafter "KitchenAid") will pay for factory specified replacement parts and repair labor to correct defects in materials or workmanship that existed when this major appliance was purchased or, at its sole discretion replace the product. In the event of product replacement, your appliance will be warranted for the remaining term of the original unit's warranty period.

SECOND THROUGH FIFTH YEAR LIMITED WARRANTY (CERTAIN COMPONENT PARTS ONLY - LABOR NOT INCLUDED)

In the second through fifth years from the date of original purchase, when this major appliance is installed, operated and maintained according to instructions attached to or furnished with the product, KitchenAid will pay for factory specified parts for the following components to correct non-cosmetic defects in materials or workmanship in these parts that prevent function of this major appliance and that existed when this major appliance was purchased. This is a limited 5-year warranty on the below named parts only and does not include repair labor.

- Electric element
- Gas burners
- Solid state touch control system parts
- Any cracking of the rubber seal between the ceramic glass cooktop and porcelain edge
- Any cracking due to thermal shock of the ceramic glass cooktop
- Surface unit elements

YOUR SOLE AND EXCLUSIVE REMEDY UNDER THIS LIMITED WARRANTY SHALL BE PRODUCT REPAIR AS PROVIDED HEREIN. Service must be provided by a KitchenAid designated service company. This limited warranty is valid only in the United States or Canada and applies only when the major appliance is used in the country in which it was purchased. This limited warranty is effective from the date of original consumer purchase. Proof of original purchase date is required to obtain service under this limited warranty.

WHAT IS NOT COVERED

1. Commercial, non-residential, multiple-family use, or use inconsistent with published user, operator or installation instructions.
2. In-home instruction on how to use your product.
3. Service to correct improper product maintenance or installation, installation not in accordance with electrical or plumbing codes or correction of household electrical or plumbing (i.e. house wiring, fuses or water inlet hoses).
4. Consumable parts (i.e. light bulbs, batteries, air or water filters, preservation solutions, etc.).
5. Defects or damage caused by the use of non-genuine KitchenAid parts or accessories.
6. Conversion of products from natural gas or Propane gas.
7. Damage from accident, misuse, abuse, fire, floods, acts of God or use with products not approved by KitchenAid.
8. Repairs to parts or systems to correct product damage or defects caused by unauthorized service, alteration or modification of the appliance.
9. Cosmetic damage including scratches, dents, chips, and other damage to the appliance finishes unless such damage results from defects in materials and workmanship and is reported to KitchenAid within 30 days.
10. Discoloration, rust or oxidation of surfaces resulting from caustic or corrosive environments including but not limited to high salt concentrations, high moisture or humidity or exposure to chemicals.
11. Food or medicine loss due to product failure.
12. Pick-up or delivery. This product is intended for in-home repair.
13. Travel or transportation expenses for service in remote locations where an authorized KitchenAid servicer is not available.
14. Removal or reinstallation of inaccessible appliances or built-in fixtures (i.e. trim, decorative panels, flooring, cabinetry, islands, countertops, drywall, etc.) that interfere with servicing, removal or replacement of the product.
15. Service or parts for appliances with original model/serial numbers removed, altered or not easily determined.

The cost of repair or replacement under these excluded circumstances shall be borne by the customer.

DISCLAIMER OF IMPLIED WARRANTIES

IMPLIED WARRANTIES, INCLUDING ANY IMPLIED WARRANTY OF MERCHANTABILITY OR IMPLIED WARRANTY OF FITNESS FOR A PARTICULAR PURPOSE, ARE LIMITED TO FIVE YEARS OR THE SHORTEST PERIOD ALLOWED BY LAW. Some states and provinces do not allow limitations on the duration of implied warranties of merchantability or fitness, so this limitation may not apply to you. This warranty gives you specific legal rights, and you also may have other rights that vary from state to state or province to province.

DISCLAIMER OF REPRESENTATIONS OUTSIDE OF WARRANTY

KitchenAid makes no representations about the quality, durability, or need for service or repair of this major appliance other than the representations contained in this warranty. If you want a longer or more comprehensive warranty than the limited warranty that comes with this major appliance, you should ask KitchenAid or your retailer about buying an extended warranty.

LIMITATION OF REMEDIES; EXCLUSION OF INCIDENTAL AND CONSEQUENTIAL DAMAGES

YOUR SOLE AND EXCLUSIVE REMEDY UNDER THIS LIMITED WARRANTY SHALL BE PRODUCT REPAIR AS PROVIDED HEREIN. KITCHENAID SHALL NOT BE LIABLE FOR INCIDENTAL OR CONSEQUENTIAL DAMAGES. Some states and provinces do not allow the exclusion or limitation of incidental or consequential damages, so these limitations and exclusions may not apply to you. This warranty gives you specific legal rights, and you also may have other rights that vary from state to state or province to province.

CLAUSE D'EXONÉRATION DE RESPONSABILITÉ AU TITRE DES GARANTIES IMPLICITES

LES GARANTIES IMPLICITES, Y COMPRIS LES GARANTIES APPLICABLES DE QUALITÉ MARCHANDE OU D'APTITUDE À UN USAGE PARTICULIER, SONT LIMITÉES À CINQ ANS OU À LA PLUS COURTE PÉRIODE AUTORISÉE PAR LA LOI. Certains États et certaines provinces ne permettent pas de limitation sur la durée des garanties implicites de qualité marchande ou d'aptitude à un usage particulier, de sorte que la limitation ci-dessus peut ne pas être applicable dans votre cas. Cette garantie vous confère des droits juridiques spécifiques et vous pouvez également jouir d'autres droits qui peuvent varier d'une juridiction à l'autre.

EXONÉRATION DE RESPONSABILITÉ DANS LES DOMAINES NON COUVERTS PAR LA GARANTIE

KitchenAid décline toute responsabilité au titre de la qualité, de la durabilité ou en cas de dépannage ou de réparation nécessaire sur ce gros appareil ménager autre que les responsabilités énoncées dans la présente garantie. Si vous souhaitez une garantie plus étendue ou plus complète que la garantie limitée fournie avec ce gros appareil ménager, adressez-vous à KitchenAid ou à votre détaillant pour obtenir les modalités d'achat d'une garantie étendue.

LIMITATION DES RECOURS; EXCLUSION DES DOMMAGES FORTUITS OU INDIRECTS

LE SEUL ET EXCLUSIF RECOURS DU CLIENT DANS LE CADRE DE LA PRÉSENTE GARANTIE LIMITÉE CONSISTE EN LA RÉPARATION PRÉVUE PAR LA PRÉSENTE. KITCHENAID N'ASSUME AUCUNE RESPONSABILITÉ POUR LES DOMMAGES FORTUITS OU INDIRECTS. Certains États et certaines provinces ne permettent pas l'exclusion ou la limitation des dommages fortuits ou indirects de sorte que ces limitations et exclusions peuvent ne pas être applicables dans votre cas. Cette garantie vous confère des droits juridiques spécifiques et vous pouvez également jouir d'autres droits qui peuvent varier d'une juridiction à l'autre.

11/14