

INSTALLATION INSTRUCTIONS

R-410A Split System Air Conditioner

C4A3, H4A3, T4A3,
CXA6, HXA6, TXA6

These instructions must be read and understood completely before attempting installation.

IMPORTANT: Effective January 1, 2015, all split system and packaged air conditioners must be installed pursuant to applicable regional efficiency standards issued by the Department of Energy.

SAFETY CONSIDERATIONS

Improper installation, adjustment, alteration, service, maintenance, or use can cause explosion, fire, electrical shock, or other conditions which may cause death, personal injury, or property damage. Consult a qualified installer, service agency, or your distributor or branch for information or assistance. The qualified installer or agency must use factory-authorized kits or accessories when modifying this product. Refer to the individual instructions packaged with the kits or accessories when installing.

Follow all safety codes. Wear safety glasses, protective clothing, and work gloves. Use quenching cloth for brazing operations. Have fire extinguisher available. Read these instructions thoroughly and follow all warnings or cautions included in literature and attached to the unit. Consult local building codes and current editions of the National Electrical Code (NEC) NFPA 70. In Canada, refer to current editions of the Canadian electrical code CSA 22.1.

Recognize safety information. This is the safety-alert symbol  When you see this symbol on the unit and in instructions or manuals, be alert to the potential for personal injury. Understand these signal words; DANGER, WARNING, and CAUTION. These words are used with the safety-alert symbol. DANGER identifies the most serious hazards which **will** result in severe personal injury or death. WARNING signifies hazards which **could** result in personal injury or death. CAUTION is used to identify unsafe practices which **would** result in minor personal injury or product and property damage. NOTE is used to highlight suggestions which **will** result in enhanced installation, reliability, or operation.



WARNING

ELECTRICAL SHOCK HAZARD

Failure to follow this warning could result in personal injury or death.

Before installing, modifying, or servicing system, main electrical disconnect switch must be in the OFF position. There may be more than 1 disconnect switch. Lock out and tag switch with a suitable warning label.



WARNING

EXPLOSION HAZARD

Failure to follow this warning could result in death, serious personal injury, and/or property damage.

Never use air or gases containing oxygen for leak testing or operating refrigerant compressors. Pressurized mixtures of air or gases containing oxygen can lead to an explosion.



INSPECT NEW UNIT

After uncrating the unit, inspect it thoroughly for any obvious or hidden damage. If damage is found, notify the transportation company immediately and file a concealed damage claim.



CAUTION

PROPERTY DAMAGE HAZARD

Failure to follow this caution may result in property damage

R-410A systems operate at higher pressures than R-22 systems. When working with R-410A systems, use only service equipment and replacement components specifically rated or approved for R-410A service.



CAUTION

CUT HAZARD

Failure to follow this caution may result in personal injury.

Sheet metal parts may have sharp edges or burrs. Use care and wear appropriate protective clothing and gloves when handling parts.

LOCATION

Check local codes for regulations concerning zoning, noise, platforms, and other issues.

Locate unit away from fresh air intakes, vents, or bedroom windows. Noise may carry into the openings and disturb people inside.

Locate unit in a well drained area, or support unit high enough so that water runoff will not enter the unit.

Locate unit away from areas where heat, lint, or exhaust fumes will be discharged onto unit (as from dryer vents).

Locate unit away from recessed or confined areas where recirculation of discharge air may occur (refer to CLEARANCES section of this document).

Roof-top installation is acceptable providing the roof will support the unit and provisions are made for water drainage and noise/vibration dampening.

NOTE: Roof mounted units exposed to wind may require wind baffles. Consult the manufacturer for additional information.

CLEARANCES

When installing, allow sufficient space for airflow clearance, wiring, refrigerant piping, and service. Allow 24 in. (610 mm) clearance to service end of unit and 48 in. (1219.2 mm) above unit. For proper airflow, a 6 in. (152.4 mm) clearance on one side of unit and 12 in. (304.8 mm) on all remaining sides must be maintained. Maintain a distance of 24 in. (609.6 mm) between units or 18 in. (457.2 mm) if no overhang within 12 ft. (3.66 m). Position so water, snow, or ice from roof or eaves cannot fall directly on unit.

Operating Ambient

The minimum outdoor operating ambient in cooling mode without accessory is 55°F (12.78°C). The maximum outdoor operating ambient in cooling mode is 125°F (51.7°C) for non-13 SEER models and 115°F (46.11°C) for 13 SEER models.

UNIT SUPPORT

NOTE: Unit must be level ± 2 degrees [a 3/8 inch rise or fall per foot of run (10 mm rise or fall per 305 mm of run)] or compressor may not function properly.

A. GROUND LEVEL INSTALLATION

The unit must be level and supported above grade by beams, platform, or a pad. Platform or pad can be of open or solid construction but should be of permanent materials such as concrete, bricks, blocks, steel, or pressure-treated timbers approved for ground contact. Soil conditions must be considered so that the platform

or pad does not shift or settle and leave the unit partially supported. Minimum pad dimensions are shown in Figure 1.

If beams or an open platform are used for support, it is recommended that the soil be treated or area be graveled to reduce the growth of grasses and weeds.

To minimize vibration or noise transmission, it is recommended that supports not be in contact with the building structure. However, slabs on grade constructions with an extended pad are normally acceptable.

B. ROOF TOP INSTALLATION

This type of installation is not recommended on wood frame structures where low noise levels are required.

Supporting structure or platform for the unit must be level. If installation is on a flat roof, locate unit minimum 6 inches (152 mm) above roof level.

Place the unit over one or more load bearing walls. If there are several units, mount them on platforms that are self-supporting and span several load bearing walls. These suggestions are to minimize noise and vibration transmission through the structure. If the structure is a home or apartment, avoid locating the unit over bedrooms or study.

NOTE: When unit is to be installed on a bonded guaranteed roof, a release must be obtained from the building owner to free the installer from all liabilities.

C. FASTENING UNIT DOWN

If conditions or local codes require the unit be attached in place, remove the knockouts in the base pan and install tie down bolts through the holes (refer to Figure 1).

Contact local distributor for hurricane hold-down details and the P.E. (Professional Engineer) certification, when required.

	CAUTION
PROPERTY DAMAGE HAZARD	
<p>Failure to follow this caution may result in property damage.</p> <p>Inadequate unit support may cause excessive vibration, noise, and/or stress on the refrigerant lines, leading to refrigerant line failure.</p>	

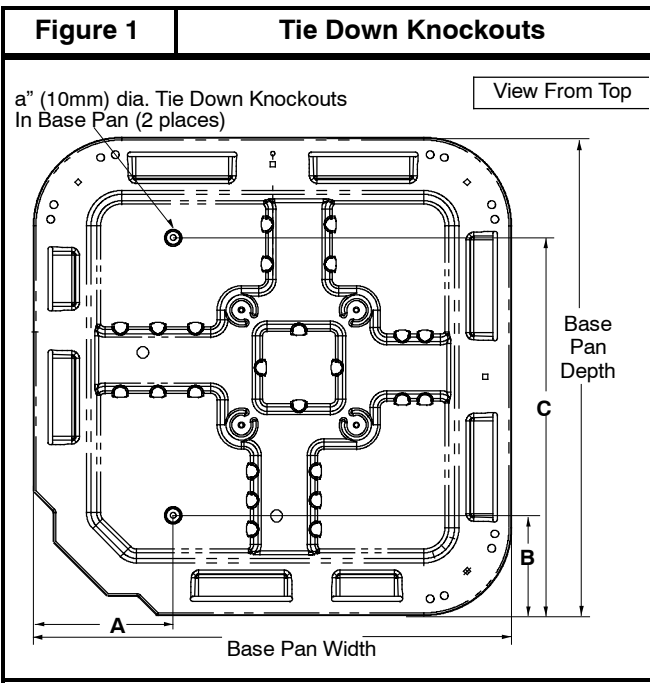

Inches (mm)				
Base Pan Width x Depth	Tie Down Knockouts			Minimum Mounting Pad Dimensions
	A	B	C	
23 x 23 (584 x 584)	7-3/4 (197)	4-7/16 (113)	18 (457)	23 x 23 (584 x 584)
25-11/16 x 25-11/16 (652 x 652)	9-1/16 (230)	4-7/16 (113)	21-1/4 (540)	26 x 26 (660 x 660)
31-1/8 x 31-1/8 (791 x 791)	9-1/16 (230)	6-1/2 (165)	24-5/8 (625)	31-1/2 x 31-1/2 (800 x 800)
34-15/16 x 34-15/16 (887 x 887)	9-1/16 (230)	6-1/2 (165)	28-7/16 (722)	35 x 35 (889 x 889)

REFRIGERATION SYSTEM

A. COMPONENT MATCHES

Check to see that the proper system components are in place, especially the indoor coil.

R-410A outdoor units can only be used with R-410A specific indoor coils. If there is a refrigerant mis-match, consult the indoor coil manufacturer to determine if a refrigerant conversion kit is available for the indoor coil.

This outdoor unit is designed for use only with indoor coils that utilize a TXV refrigerant metering device or Piston with Teflon ring metering device. If any other type of metering device is installed on the indoor coil, consult the indoor coil manufacturer to determine if a TXV conversion kit is available.

Installing with TXV

When installing a TXV on an indoor coil, follow the instructions provided with the new TXV.

A typical TXV installation is shown in Figure 2.

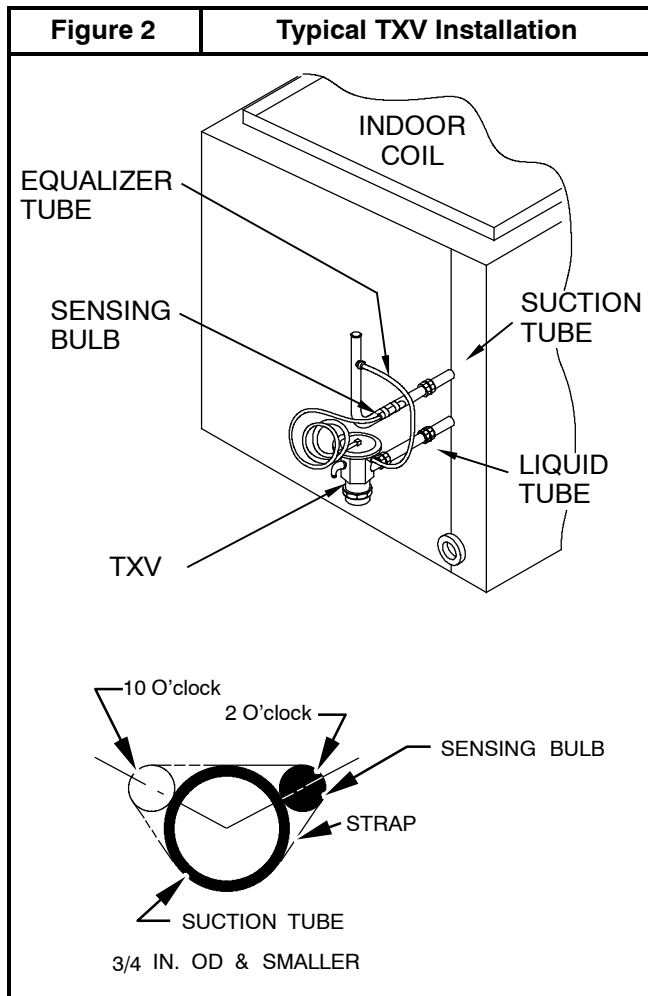

Installing with Indoor Piston - cooling operation.

Check piston size shipped with indoor unit to see if it matches required indoor piston size. If it **does not** match, replace indoor piston with the correct piston size.

NOTE: Correct pistons are shipped with select outdoor units in the accessory bag and are only for use in certain qualified and approved fancoils, i.e. FEM4P. (See Product Specifications for list of approved fancoils that use accessory piston.)

The piston included with the FMA4P* and FM(C,U)4P* fancoils are unique to those products and **cannot** be replaced with the piston shipped with the outdoor unit. Refer to the AHRI Directory to check if your combination can use a piston or requires an accessory TXV.

See Figure 3.

When changing indoor piston, use a back-up wrench. Hand tighten hex nut, then tighten with wrench 1/2 turn. Do not exceed 30 ft-lbs. The indoor piston contains a Teflon ring (or seal) which is used to seat against the inside of distributor body, and must be installed properly to ensure proper seating in the direction for cooling operation.

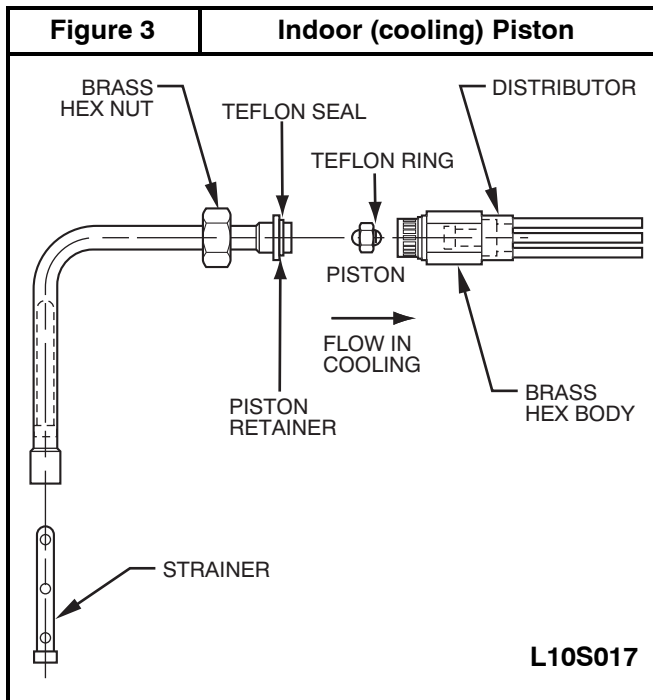

B. REFRIGERANT LINE SETS

The refrigerant line set must be properly sized to assure maximum efficiency and proper oil circulation.

Refer to Product Specifications and Long Line Applications Guideline for line set sizing.

NOTE: Total line set length must not exceed 200 feet (61 m).

A crankcase heater must be used when the refrigerant line length exceeds 80 feet (24.4 m).

If outdoor unit is more than 10 feet (3 m) higher than the indoor coil, refer to the Long Line Applications Guideline for instructions.

When the outdoor unit is higher than the indoor coil, the vertical separation must not exceed 100 feet (30 m).

When the outdoor unit is lower than the indoor coil, the vertical separation must not exceed 50 feet (15.2 m).

If it is necessary to add refrigerant line in the field, use dehydrated or dry, sealed, deoxidized, copper refrigeration tubing. Do not use copper water pipe.

Do not remove rubber plugs or caps from copper tubing until connections are ready to be made.

Be extra careful when bending refrigeration tubing. Tubing can “kink” easily, and if this occurs, the entire length of tubing must be replaced.

⚠ WARNING

PERSONAL INJURY HAZARD

Failure to relieve system pressure could result in personal injury and/or death.

Relieve pressure and recover all refrigerant before servicing existing equipment, and before final unit disposal. Use all service ports and open all flow-control devices, including solenoid valves.

C. ROUTING AND SUSPENDING REFRIGERANT LINES

Run refrigerant lines as straight and direct as possible, avoiding unnecessary bends and turns. Always insulate the entire suction line. Both lines should be insulated when routed through an attic or when routed through an underground raceway.

When routing refrigerant lines through a foundation or wall, do not allow refrigerant lines to come in direct contact with the building structure. Make openings large enough so that lines can be wrapped with extra insulation. Fill all gaps with RTV caulk. This will prevent noise transmission between the tubing and the foundation or wall.

Along floor or ceiling joists, suspend refrigerant lines so that they do not contact the building structure, water pipes, or ductwork. Use insulated or suspension type hangers. Metal straps must be at least 1” (25 mm) wide to avoid cutting into the tube insulation. Keep the liquid and suction lines separate. Refer to Figure 4.

⚠ CAUTION

UNIT OPERATION HAZARD

Failure to follow this caution may result in improper product operation.

Do not leave system open to atmosphere any longer than absolutely required for installation. Internal system components - especially refrigerant oils - are extremely susceptible to moisture contamination. Keep ends of tubing sealed during installation until the last possible moment.

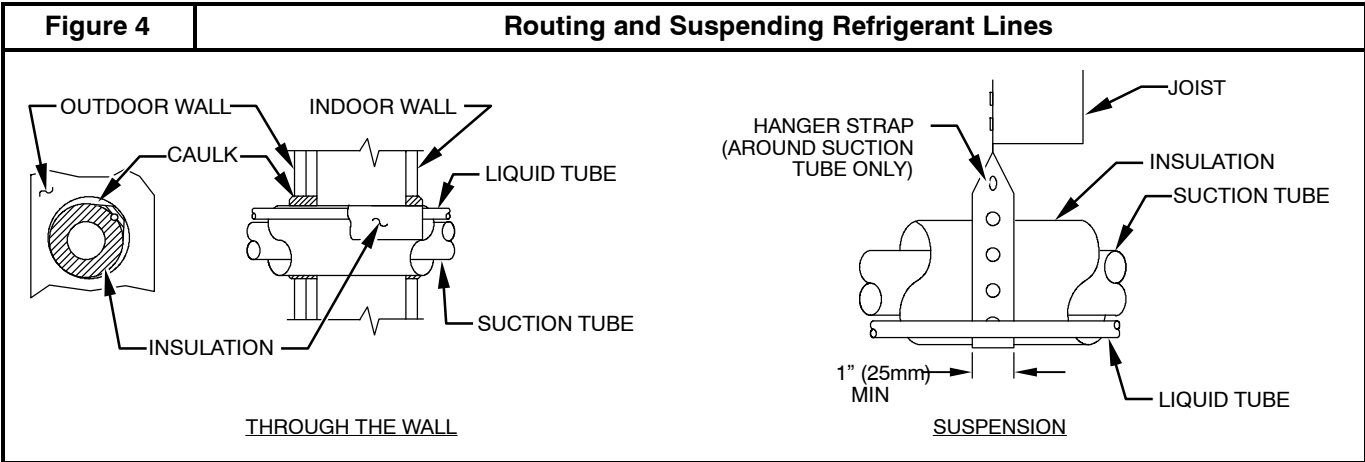

!

CAUTION

UNIT OPERATION HAZARD

Failure to follow this caution may result in improper product operation.

Do not bury more than 36" (1m) of line set underground. Refrigerant may migrate to cooler buried section during extended periods of unit shut-down, causing refrigerant slugging and possible compressor damage at start-up.

If ANY section of the line set is buried underground, provide a minimum 6" (152mm) vertical rise at the service valve.

D. OUTDOOR UNIT HIGHER THAN INDOOR UNIT

Proper oil return to the compressor should be maintained with suction gas velocity. If velocities drop below 1500 fpm (feet per minute), oil return will be decreased. To maintain suction gas velocity, do not upsize vertical suction risers.

E. LIQUID LINE FILTER-DRIER

Outdoor units are shipped with an appropriate filter-drier for installation in the liquid line. Leave the plugs in the tube ends until the filter-drier is installed. The optimal location for the filter-drier is close to the indoor coil. Install the filter-drier with the arrow pointing towards the indoor coil. Refer to Figure 5.

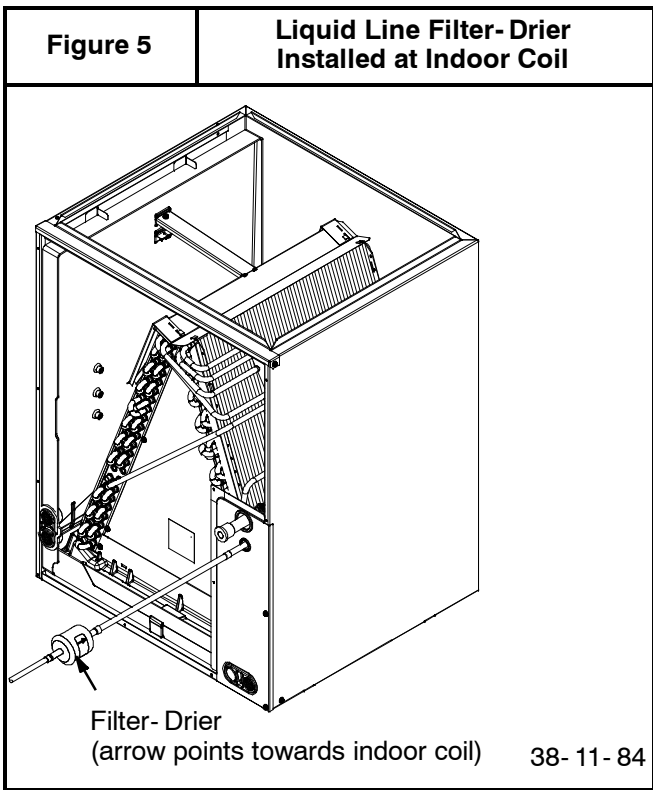

F. SERVICE VALVES

Service valves are closed and tube stubs are plugged from the factory. Outdoor units are shipped with a refrigerant charge sealed in the unit. Leave the service valves closed until all other refrigerant system work is complete or the charge will be lost. Leave the plugs in place until line set tubing is ready to be inserted. Service valve bodies are brass and tube stubs are copper.

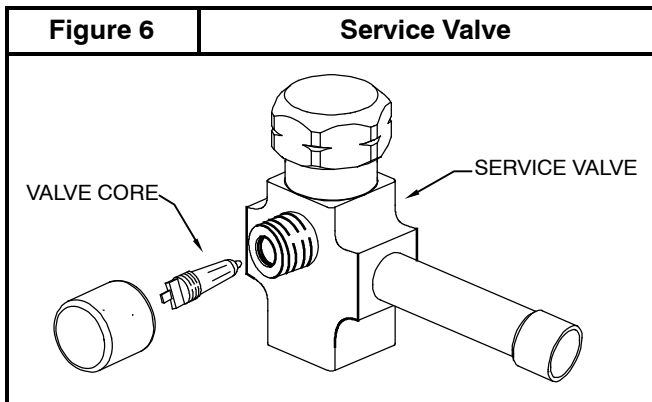

G. BRAZING CONNECTIONS

NOTE: Remove valve core from schrader port on both Service Valves BEFORE brazing. This helps prevent overheating and damage to valve seals (refer to Figure 6). Replace valve core when brazing is completed.

⚠ WARNING

FIRE HAZARD

Failure to remove refrigerant and oil charge before brazing could result in personal injury, death, and/or property damage.

Refrigerant and oil mixture could ignite and burn as it escapes and contacts brazing torch. Make sure the refrigerant charge is properly removed from both the high and low sides of the system before brazing any component or lines.

Clean line set tube ends with emery cloth or steel brush. Remove any grit or debris.

Insert line set tube ends into service valve tube stubs.

Apply heat absorbing paste or heat sink product between service valve and joint. Wrap service valves with a heat sinking material such as a wet cloth.

Braze joints using a Sil-Fos or Phos-copper alloy.

⚠ CAUTION

PRODUCT DAMAGE HAZARD

Failure to follow this caution may result in product damage.

Braze with Sil-Fos or Phos-copper alloy on copper-to-copper joints and wrap a wet cloth around rear of fitting to prevent damage to TXV.

H. EVACUATING LINE SET AND INDOOR COIL

The unit is shipped with a factory refrigerant charge. The liquid line and suction line service valves have been closed after final testing at the factory. Do not disturb these valves until the line set and indoor coil have been evacuated and leak checked, or the charge in the unit may be lost.

NOTE: Do not use any portion of the factory charge for purging or leak testing. The factory charge is for filling the system only after a complete evacuation and leak check has been performed.

⚠ CAUTION

PRODUCT DAMAGE HAZARD

Failure to follow this caution may result in product damage.

Never use the outdoor unit compressor as a vacuum pump. Doing so may damage the compressor.

Line set and indoor coil should be evacuated using the recommended deep vacuum method of 500 microns. If deep vacuum equipment is not available, the alternate triple evacuation method may be used by following the specified procedure.

If vacuum must be interrupted during the evacuation procedure, always break vacuum with dry nitrogen.

Deep Vacuum Method

The deep vacuum method requires a vacuum pump capable of pulling a vacuum to 500 microns and a vacuum gauge capable of accurately measuring this vacuum level. The deep vacuum method is the most positive way of assuring a system is free of air and water.

Watch the vacuum gauge as the system is pulling down. The response of the gauge is an indicator of the condition of the system (refer to Figure 7).

With no leaks in the system, allow the vacuum pump to run for 30 minutes minimum at the deep vacuum level.

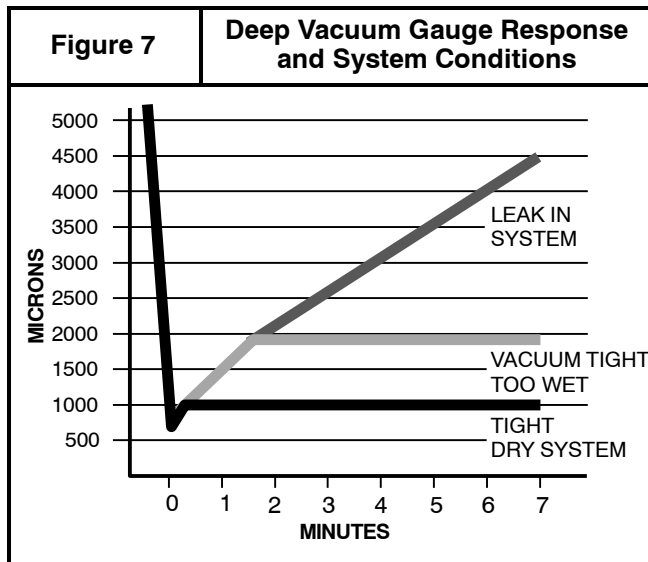

Triple Evacuation Method

The triple evacuation method should only be used when system does not contain any water in liquid form and vacuum pump is only capable of pulling down to 28 inches of mercury (711mm Hg). Refer to Figure 8 and proceed as follows:

1. Pull system down to 28 inches of mercury (711mm Hg) and allow pump to continue operating for an additional 15 minutes.
2. Close manifold valves or valve at vacuum pump and shut off vacuum pump.
3. Connect a nitrogen cylinder and regulator to system and fill with nitrogen until system pressure is 2 psig.

4. Close nitrogen valve and allow system to stand for 1 hour. During this time, dry nitrogen will diffuse throughout the system absorbing moisture.
5. Repeat this procedure as indicated in Figure 8.
6. After the final evacuate sequence, confirm there are no leaks in the system. If a leak is found, repeat the entire process after repair is made.

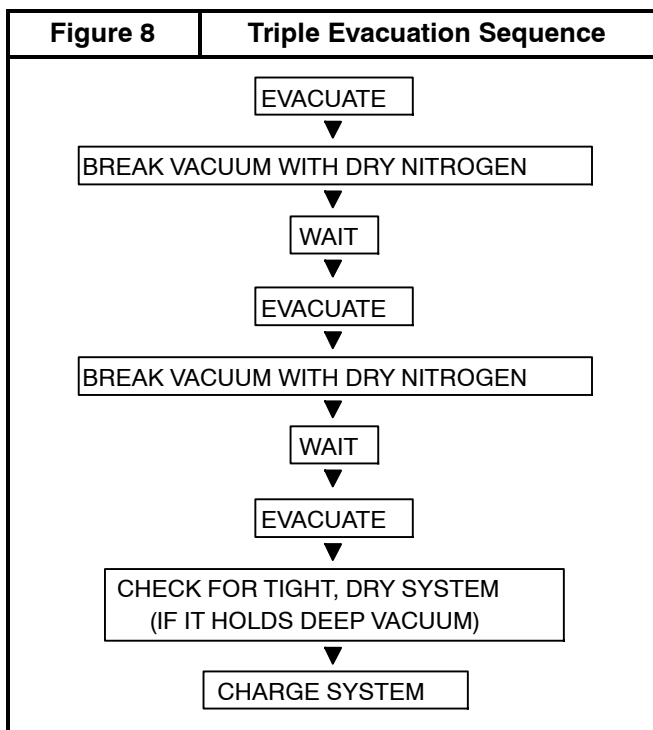

I. OPENING SERVICE VALVES

Outdoor units are shipped with a refrigerant charge sealed in the unit. Opening the service valves releases this charge into the system.

NOTE: Open the Suction service valve first. If the Liquid service valve is opened first, oil from the compressor may be drawn into the indoor coil TXV, restricting refrigerant flow and affecting operation of the system.

Remove Suction service valve cap and insert a hex wrench into the valve stem. Hold the valve body steady with an end-wrench and back out the stem by turning the hex wrench counterclockwise. Turn the stem until it just contacts the rolled lip of the valve body.

After the refrigerant charge has bled into the system, open the Liquid service valve.

NOTE: These are not back-seating valves. It is not necessary to force the stem tightly against the rolled lip.

The service valve cap is a primary seal for the valve and must be properly tightened to prevent leaks. Make sure cap is clean and apply refrigerant oil to threads and sealing surface on inside of cap.

Tighten cap finger tight and then tighten additional 6 of a turn (1 wrench flat) to properly seat the sealing surfaces.

J. GAUGE PORTS

Check for leaks at the schrader ports and tighten valve cores if necessary. Install plastic caps finger tight.

ELECTRICAL WIRING
 (*XA6 all sizes; *4A3 sizes 18, 36- 60 only)

NOTE: *4A3 sizes 24 and 30 on page 14.

⚠ WARNING

ELECTRICAL SHOCK HAZARD

Failure to turn off the main (remote) electrical disconnect device could result in personal injury or death.

Before installing, modifying or servicing system, turn OFF the main (remote) electrical disconnect device. There may be more than one disconnect device.

The supply voltage must be 208/230 volts (197 volt minimum to 253 volts maximum) 60 Hz single phase.

Outdoor units are approved for use with copper conductors only. Do not use aluminum wire.

Refer to unit rating plate for minimum circuit ampacity and circuit protection requirements.

Grounding

Permanently ground unit in accordance with the National Electrical Code and local codes or ordinances. Use a copper conductor of the correct size from the grounding lug in control box to a grounded connection in the service panel or a properly driven and electrically grounded ground rod.

Wiring Connections

Make all outdoor electrical supply (Line Voltage) connections with raintight conduit and fittings. Most codes require a disconnect switch outdoors within sight of the unit. Consult local codes for special requirements.

Route electrical supply (Line Voltage) wiring through knockout hole in bottom of Control Box. Connect wires to Contactor and Ground Lug according to Wiring Diagram on unit. Refer to Figure 9.

Route thermostat wiring through rubber grommet in bottom of Control Box. Low voltage lead wires are provided in the control box for connection to thermostat wires (use wire nuts). Refer to Wiring Diagram on unit and Figure 10 for low voltage wiring examples.

NOTE: Use No. 18 AWG (American Wire Gage) color-coded, insulated (35 °C minimum) wire. If thermostat is located more than 100 feet (31 m) from unit as measured along the control voltage wires, use No. 16 AWG color-coded wires to avoid excessive voltage drop.

NOTE: Some models are factory equipped with Comfort Alert™ Diagnostics device. If Comfort Alert is used as a field installed option, then a hot bundle must be run for proper connection.

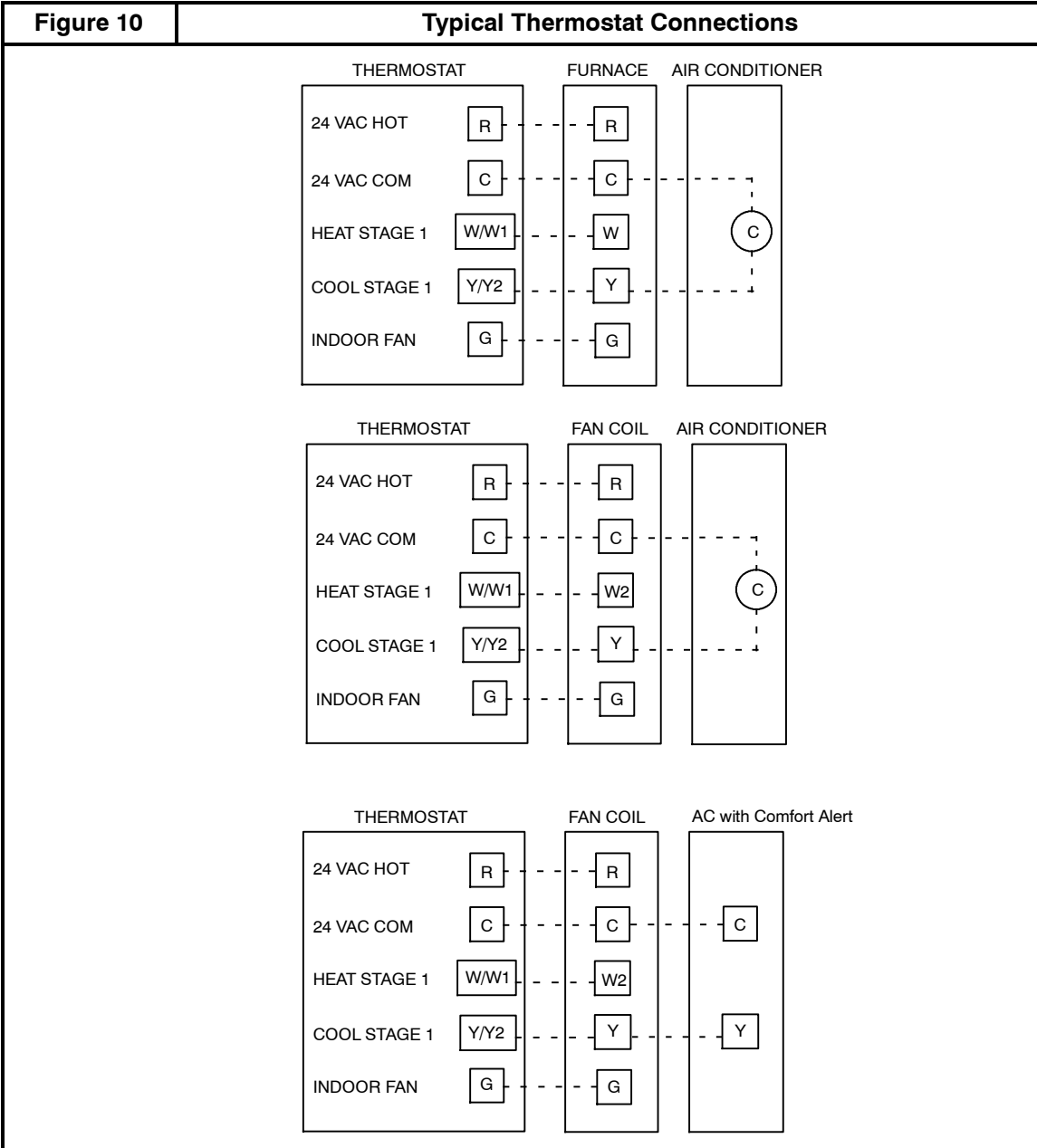
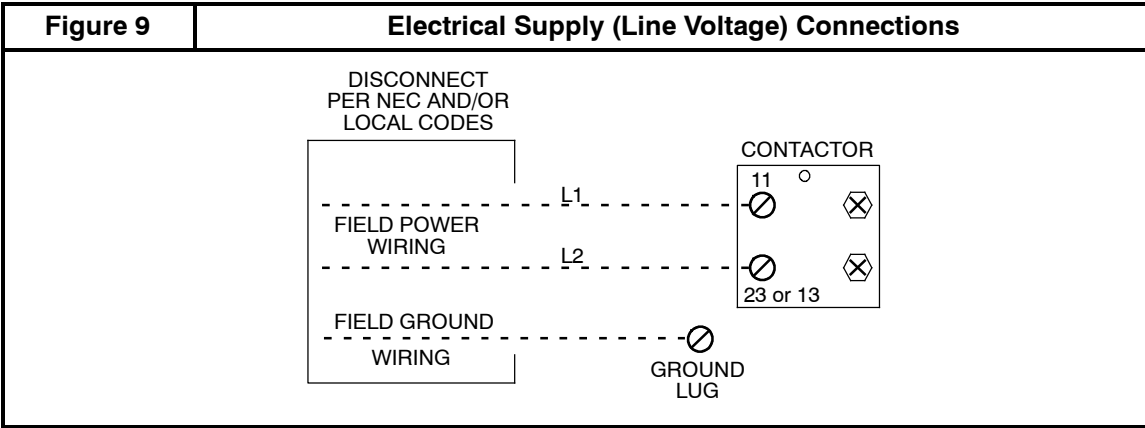

START-UP PROCEDURE

1. Set indoor thermostat selector switch to OFF.
2. Turn ON all electrical disconnect devices.
3. If unit has a crankcase heater, energize the heater and wait 24 hours before proceeding.
4. Set indoor thermostat at desired temperature. Be sure setpoint is below indoor ambient temperature or thermostat will not call for cooling.
5. Set indoor thermostat selector switch to COOL. Operate unit for minimum 15 minutes, then check the system refrigerant charge.

REFRIGERANT CHARGE

Factory charge amount and desired subcooling are shown on unit rating plate. Charging method is shown on information plate inside unit.

For TXV, use subcooling method.

For Piston, use superheat method.

To properly check or adjust charge, conditions must be favorable for subcooling or superheat charging. Favorable conditions exist when the outdoor temperature is between 70°F and 100°F (21°C and 38°C), and the indoor temperature is between 70°F and 80°F (21°C and 27°C). Follow the procedure below.

Unit is factory charged for 15 feet (4.6 m) of lineset. Adjust charge by adding or removing 0.6 oz/ft (17 g/mm) of 3/8 liquid line above or below 15 feet (4.6 m) respectively.

For standard refrigerant line lengths 80 feet (24.4 m) or less, allow system to operate in cooling mode at least 15 minutes. If conditions are favorable, check system charge by super heat method for fixed metering device and subcooling method for TXV. If any adjustment is necessary, adjust charge slowly and allow system to operate for 15 minutes to stabilize before declaring a properly charged system.

If the indoor temperature is above 80°F (27°C), and the outdoor temperature is in the favorable range, adjust system charge by weight based on line length and allow the indoor temperature to drop to 80°F (27°C) before attempting to check system charge by subcooling method as described above.

If the indoor temperature is below 70°F (21°C), or the outdoor temperature is not in the favorable range, adjust charge for line set length above or below 15 feet (4.6 m) only. Charge level should then be appropriate for the system to achieve rated capacity. The charge level could then be checked at another time when the both indoor and outdoor temperatures are in a more favorable range.

NOTE: If line length is beyond 80 feet (24.4 m) or greater than 35 feet (10.7 m) vertical separation, See Long Line Guideline for special charging requirements.

A. UNITS WITH COOLING MODE TXV

Units installed with cooling mode TXV require charging by the subcooling method.

1. Operate unit a minimum of 15 minutes before checking charge.

NOTE: If outdoor unit has a 2-speed fan motor, motor will operate in low speed when outdoor ambient temperature is below 82°F. Pull one of the yellow low voltage wires off the fan control and the unit will default to high speed fan for servicing. Reconnect wire after servicing.

2. Measure liquid service valve pressure by attaching an accurate gage to service port.
3. Measure liquid line temperature by attaching an accurate thermistor type or electronic thermometer to liquid line near outdoor coil.
4. Refer to unit rating plate for required subcooling temperature.
5. Refer to Figure 13. Find the point where required subcooling temperature intersects measured liquid service valve pressure.
6. To obtain required subcooling temperature at a specific liquid line pressure, add refrigerant if liquid line temperature is higher than indicated or reclaim refrigerant if temperature is lower. Allow a tolerance of $\pm 3^{\circ}\text{F}$ ($\pm 1.7^{\circ}\text{C}$).

B. UNITS WITH INDOOR PISTON

Units installed with indoor pistons require charging by the superheat method.

The following procedure is valid when indoor airflow is within ± 21 percent of its rated CFM.

1. Operate unit a minimum of 15 minutes before checking charge.
2. Measure suction pressure by attaching an accurate gage to suction valve service port.
3. Measure suction temperature by attaching an accurate thermistor type or electronic thermometer to suction line at service valve.
4. Measure outdoor air dry-bulb temperature with thermometer.
5. Measure indoor air (entering indoor coil) wet-bulb temperature with a sling psychrometer.
6. Find outdoor temperature and evaporator entering air wet-bulb temperature. At this intersection, note superheat. Where a dash (- -) appears on the table, do not attempt to charge system under these conditions or refrigerant slugging may occur. Charge must be weighted in, adding or removing 0.6 oz/ft of 3/8 liquid line above or below 15 feet (4.6 m) respectively.
7. Find superheat temperature (from #6 above) and suction pressure. At this intersection, note suction line temperature.
8. If unit has a higher suction line temperature than charted temperature, add refrigerant until charted temperature is reached.
9. If unit has a lower suction line temperature than charted temperature, reclaim refrigerant until charted temperature is reached.
10. When adding refrigerant, charge in liquid form into suction service port using a flow-restricting device.
11. If outdoor air temperature or pressure at suction valve changes, charge to new suction line temperature indicated on chart.

12. Optimum performance will be achieved when the operating charge produces 10°F suction superheat at suction service valve with 95°F (35°C) outdoor ambient and 80°F (27°C) dry bulb (67°F / 19°C) wet bulb indoor temperature (DOE “A” test conditions) at rated airflow.

Figure 11 Outdoor Temp	SUPERHEAT CHARGING TABLE (SUPERHEAT °F AT LOW-SIDE SERVICE PORT)													SUPERHEAT CHARGING TABLE (SUPERHEAT °C AT LOW-SIDE SERVICE PORT)															
	EVAPORATOR ENTERING AIR °F AT WB													EVAPORATOR ENTERING AIR °C AT WB															
	°F = Fahrenheit													°C = Celsius															
°F	50	52	54	56	58	60	62	64	66	68	70	72	74	76	°C	10	11	12	13	14	16	17	18	19	20	21	22	23	24
55	9	12	14	17	20	23	26	29	32	35	37	40	42	45	13	5	7	8	9	11	13	14	16	18	19	21	22	23	25
60	7	10	12	15	18	21	24	27	30	33	35	38	40	43	16	4	6	7	8	10	12	13	15	17	18	19	21	22	24
65	-	6	10	13	16	19	21	24	27	30	33	36	38	41	18	-	3	6	7	9	11	12	13	15	17	18	20	21	23
70	-	-	7	10	13	16	19	21	24	27	30	33	36	39	21	-	-	4	6	7	9	11	12	13	15	17	18	20	22
75	-	-	-	6	9	12	15	18	21	24	28	31	34	37	24	-	-	-	3	5	7	8	10	12	13	16	17	19	21
80	-	-	-	-	5	8	12	15	18	21	25	28	31	35	27	-	-	-	-	3	4	7	8	10	12	14	16	17	19
85	-	-	-	-	-	8	11	15	19	22	26	30	33	29	-	-	-	-	-	4	6	8	11	12	14	17	18		
90	-	-	-	-	-	5	9	13	16	20	24	27	31	32	-	-	-	-	-	3	5	7	9	11	13	15	17		
95	-	-	-	-	-	-	6	10	14	18	22	25	29	35	-	-	-	-	-	-	3	6	8	10	12	14	16		
100	-	-	-	-	-	-	-	8	12	15	20	23	27	38	-	-	-	-	-	-	-	4	7	8	11	13	15		
105	-	-	-	-	-	-	-	5	9	13	17	22	26	41	-	-	-	-	-	-	-	3	5	7	9	12	14		
110	-	-	-	-	-	-	-	-	6	11	15	20	25	43	-	-	-	-	-	-	-	-	3	6	8	11	14		
115	-	-	-	-	-	-	-	-	-	8	14	18	23	46	-	-	-	-	-	-	-	-	-	4	8	10	13		

*Optimum performance point, 95°F (35°C) outdoor ambient and (80°F / 27°C dry bulb), (67°F / 19°C wet bulb) indoor conditions. (DOE A Test Conditions)

Where a dash (-) appears do not attempt to charge system under these conditions or refrigerant slugging may occur. Charge must be weighed in.

Note: Superheat °F is at low- side service port. Allow a tolerance of ± 3°F (± 1.7°C)

Note: Indoor dry bulb between 70°F and 80°F (21°C and 27°C)

Figure 12 SUPER-HEAT TEMP F	SUCTION PRESSURE AT SERVICE PORT PSIG										SUPER-HEAT TEMP C	SUCTION PRESSURE AT SERVICE PORT KPA									
	108	112	117	121	126	131	139	141	146	743		774	805	836	869	902	957	971	1005		
	REQUIRED SUCTION TUBE TEMPERATURE °F (MEASURED AT LOW- SIDE SERVICE PORT)											REQUIRED SUCTION TUBE TEMPERATURE °C (MEASURED AT LOW- SIDE SERVICE PORT)									
0	35	37	39	41	43	45	47	49	51	0	2	3	4	5	6	7	8	9	11		
2	37	39	41	43	45	47	49	51	53	1	3	4	5	6	7	8	9	11	12		
4	39	41	43	45	47	49	51	53	55	2	4	5	6	7	8	9	11	12	13		
6	41	43	45	47	49	51	53	55	57	3	5	6	7	8	9	11	12	13	14		
8	43	45	47	49	51	53	55	57	59	4	6	7	8	9	11	12	13	14	15		
10	45	47	49	51	53	55	57	59	61	6	7	8	9	11	12	13	14	15	16		
12	47	49	51	53	55	57	59	61	63	7	8	9	11	12	13	14	15	16	17		
14	49	51	53	55	57	59	61	63	65	8	9	11	12	13	14	15	16	17	18		
16	51	53	55	57	59	61	63	65	67	9	11	12	13	14	15	16	17	18	19		
18	53	55	57	59	61	63	65	67	69	10	12	13	14	15	16	17	18	19	21		
20	55	57	59	61	63	65	67	69	71	11	13	14	15	16	17	18	19	21	22		
22	57	59	61	63	65	67	69	71	73	12	14	15	16	17	18	19	21	22	23		
24	59	61	63	65	67	69	71	73	75	13	15	16	17	18	19	21	22	23	24		
26	61	63	65	67	69	71	73	75	77	14	16	17	18	19	21	22	23	24	25		
28	63	65	67	69	71	73	75	77	79	16	17	18	19	21	22	23	24	25	26		
30	65	67	69	71	73	75	77	79	81	17	18	19	21	22	23	24	25	26	27		

Figure 13	Rating Plate (required) Subcooling Temperature °F (°C)											
	°F 6	(°C) 3	°F 8	(°C) 4	°F 10	(°C) 6	°F 12	(°C) 7	F 14	(°C) 8	F 16	(°C) 9
	R-410A Required Liquid Line Temperature °F (°C)											
251	78	26	76	24	74	23	72	22	70	21	68	20
259	80	27	78	26	76	24	74	23	72	22	70	21
266	82	28	80	27	78	26	76	24	74	23	72	22
274	84	29	82	28	80	27	78	26	76	24	74	23
283	86	30	84	29	82	28	80	27	78	26	76	24
291	88	31	86	30	84	29	82	28	80	27	78	26
299	90	32	88	31	86	30	84	29	82	28	80	27
308	92	33	90	32	88	31	86	30	84	29	82	28
317	94	34	92	33	90	32	88	31	86	30	84	29
326	96	36	94	34	92	33	90	32	88	31	86	30
335	98	37	96	36	94	34	92	33	90	32	88	31
345	100	38	98	37	96	36	94	34	92	33	90	32
364	104	40	102	39	100	38	98	37	96	36	94	34
374	106	41	104	40	102	39	100	38	98	37	96	36
384	108	42	106	41	104	40	102	39	100	38	98	37
395	110	43	108	42	106	41	104	40	102	39	100	38
406	112	44	110	43	108	42	106	41	104	40	102	39
416	114	46	112	44	110	43	108	42	106	41	104	40
427	116	47	114	46	112	44	110	43	108	42	106	41
439	118	48	116	47	114	46	112	44	110	43	108	42
450	120	49	118	48	116	47	114	46	112	44	110	43
462	122	50	120	49	118	48	116	47	114	46	112	44
474	124	51	122	50	120	49	118	48	116	47	114	46

SEQUENCE OF OPERATION

With power supplied to indoor and outdoor units, transformer is energized.

On a call for cooling, the thermostat makes circuits R- Y and R- G. Circuit R- Y energizes contactor, starting outdoor fan motor and compressor. Circuit R- G energizes indoor unit blower relay, starting indoor blower motor.

When thermostat is satisfied, its contacts open, de- energizing contactor and blower relay. Compressor and motors stop.

NOTE: If indoor unit is equipped with a time- delay relay circuit, the blower runs an additional length of time to increase system efficiency.

TROUBLESHOOTING

Some models are factory equipped with the Comfort Alert™ Diagnostics device in the control box (refer to Figure 14). Comfort Alert provides around-the-clock monitoring for common electrical problems, compressor defects, and broad system faults. If trouble is detected, an alert code is displayed with a flashing LED indicator. Alert codes are listed in Figure 15.

The device is factory wired and requires no modification. Low voltage lead wires are provided in the control box for connection to thermostat wires (use wire nuts).

The Comfort Alert device operates by monitoring the compressor power leads and the thermostat demand signal (Y terminal).

MAINTENANCE

Condensate Drain

During the cooling season, check monthly for free flow of drainage and clean if necessary.

Cleanliness

These tips will help keep the air conditioner looking better and working more efficiently:

1. Free flow of air is essential. Keep fences, shrubs, trash cans, and other obstructions at least 18 inches (457 mm) from all coil inlets.
2. Keep the coil free of grass clippings, leaves, weeds, and other debris.
NOTE: Coil may occasionally require cleaning with a liquid solution. The coil must be cold when cleaning. Use an alkaline based cleaner only. Cleaning a hot coil or using an acid based cleaner will remove the paint from the fins and may clog the coil.
3. Never use a weather cover over the outdoor unit unless it is a ventilated type or made of breathable fabric that will allow moisture to evaporate rapidly. A cover that holds moisture in the unit will cause more rust build-up and damage than normal exposure to weather.

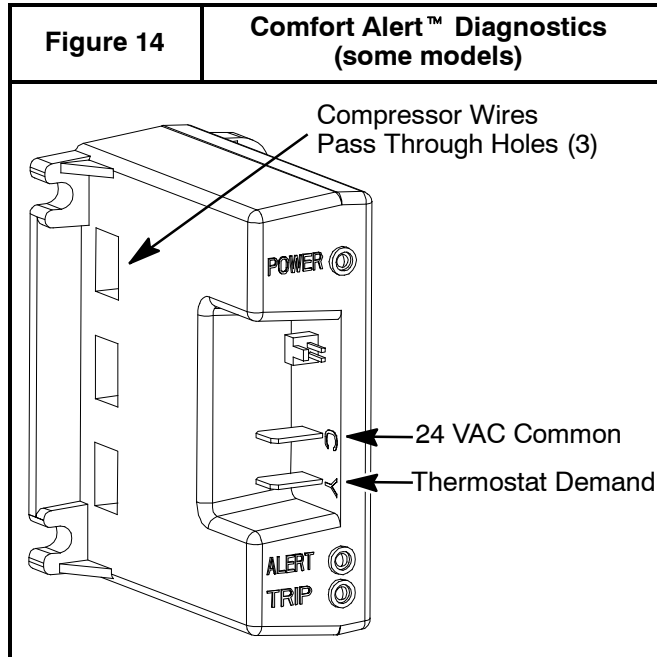

See Figure 19 for the 24 and 30 sizes for the *4A3 series.

Figure 15		Comfort Alert™ Diagnostics (*XA6 all sizes - *4A3 sizes 18, 36-60 only)	
Status LED	Status LED Description	Status LED Troubleshooting Information	
Green "POWER"	Module has power	Supply voltage is present at module terminals	
Red "TRIP"	Thermostat demand signal Y1 is present, but the compressor is not running	<ol style="list-style-type: none"> 1. Compressor protector is open 2. Outdoor unit power disconnect is open 3. Compressor circuit breaker or fuse(s) is open 4. Broken wire or connector is not making contact 5. Low pressure switch open if present in system 6. Compressor contactor has failed open 	
Yellow "ALERT" Flash Code 1	Long Run Time Compressor is running extremely long run cycles	<ol style="list-style-type: none"> 1. Low refrigerant charge 2. Evaporator blower is not running 3. Evaporator coil is frozen 4. Faulty metering device 5. Condenser coil is dirty 6. Liquid line restriction (filter drier blocked if present in system) 7. Thermostat is malfunctioning 	
Yellow "ALERT" Flash Code 2	System Pressure Trip Discharge or suction pressure out of limits or compressor overloaded	<ol style="list-style-type: none"> 1. High head pressure 2. Condenser coil poor air circulation (dirty, blocked, damaged) 3. Condenser fan is not running 4. Return air duct has substantial leakage 	
Yellow "ALERT" Flash Code 3	Short Cycling Compressor is running only briefly	<ol style="list-style-type: none"> 1. If high pressure switch open, go to Flash Code 2 information 2. If low pressure switch open, go to Flash Code 1 information 3. Thermostat demand signal is intermittent 4. Loose wiring at contactor coil 	
Yellow "ALERT" Flash Code 4	Locked Rotor	<ol style="list-style-type: none"> 1. Run capacitor has failed 2. Low line voltage (contact utility if voltage at disconnect is low) 3. Excessive liquid refrigerant in compressor 4. Compressor bearings are seized 	
Yellow "ALERT" Flash Code 5	Open Circuit	<ol style="list-style-type: none"> 1. Outdoor unit power disconnect is open 2. Compressor circuit breaker or fuse(s) is open 3. Compressor contactor has failed open 4. High pressure switch is open and requires manual reset 5. Open circuit in compressor supply wiring or connections 6. Unusually long compressor protector reset time due to extreme ambient temperature 7. Compressor windings are damaged 	
Yellow "ALERT" Flash Code 6	Open Start Circuit Current only in run circuit	<ol style="list-style-type: none"> 1. Run capacitor has failed 2. Open circuit in compressor start wiring or connections 3. Compressor start winding is damaged 	
Yellow "ALERT" Flash Code 7	Open Run Circuit Current only in start circuit	<ol style="list-style-type: none"> 1. Open circuit in compressor run wiring or connections 2. Compressor run winding is damaged 	
Yellow "ALERT" Flash Code 9	Low Voltage Control circuit < 17VAC	<ol style="list-style-type: none"> 1. Control circuit transformer is overloaded 2. Low line voltage (contact utility if voltage at disconnect is low) 	

- Flash Code number corresponds to a number of LED flashes, followed by a pause and then repeated.
- TRIP and ALERT LEDs flashing at same time means control circuit voltage is too low for operation.

ELECTRICAL WIRING (for *4A3, sizes 24 and 30 only)

IMPORTANT: Check factory wiring and field wire connections to ensure terminations are secured properly. Check wire routing to ensure wires are not in contact with tubing, sheet metal, etc.

Compressor Crankcase Heater

When equipped with a crankcase heater, furnish power to heater a minimum of 24 hr before starting unit. To furnish power to heater only, set thermostat to OFF and close electrical disconnect to outdoor unit.

A crankcase heater is required for low-ambient cooling or if refrigerant tubing is longer than 80 ft. (24.38 m). Refer to the Long Line Applications Guideline - Residential Split-System Air Conditioners and Heat Pumps Using R-410A Refrigerant.

Install Electrical Accessories

Refer to the individual instructions packaged with kits or accessories when installing.

Check OAT Thermistor and OCT Thermistor Attachments

Outdoor Air Temperature (OAT) Thermistor is factory installed by inserting the nibs on either sides of the thermistor body through a keyhole in the bottom shelf of the control box and locking it in place by turning it 90 degrees, such that the spherical end of a nib faces the front of the control box.

Check to make sure the OAT is locked in place. See Fig. 16.

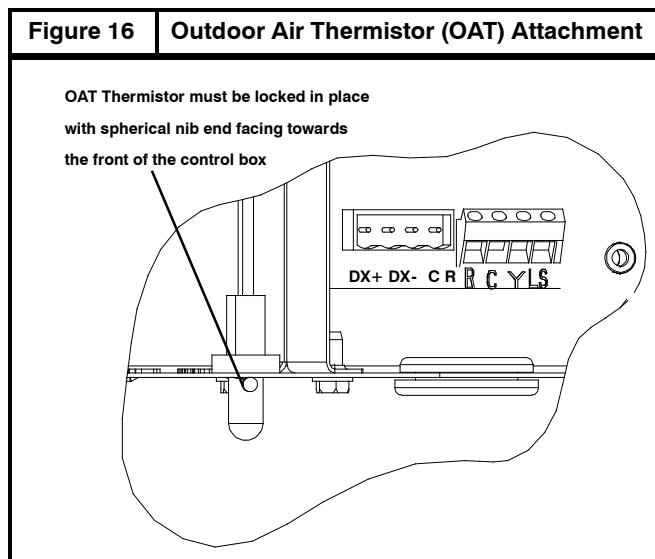

The Outdoor Coil Temperature (OCT) Thermistor is factory installed on the liquid tube between the coil assembly and the liquid service valve. See Fig. 17.

Check to make sure the thermistor is securely attached on the liquid tube with the clip as shown in Fig. 17.

Figure 17 Outdoor Coil Thermistor (OCT) Attachment

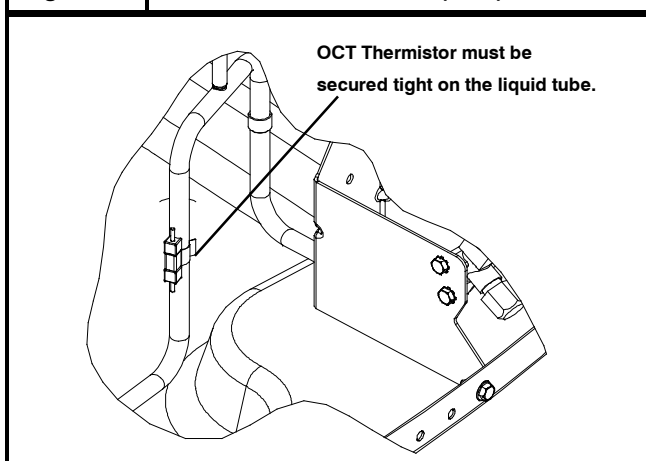

Start-Up

⚠ CAUTION

UNIT OPERATION AND SAFETY HAZARD

Failure to follow this caution may result in minor personal injury, equipment damage or improper operation.

To prevent compressor damage or personal injury, observe the following:

- Do not overcharge system with refrigerant.
- Do not operate unit in a vacuum or at negative pressure.
- Do not disable low pressure switch in scroll compressor applications.
- Dome temperatures may be hot.

⚠ CAUTION

PERSONAL INJURY HAZARD

Failure to follow this caution may result in personal injury.

Wear safety glasses, protective clothing, and gloves when handling refrigerant and observe the following:

- Front seating service valves are equipped with Schrader valves.

⚠ CAUTION

ENVIRONMENTAL HAZARD

Failure to follow this caution may result in environmental damage.

Federal regulations require that you do not vent refrigerant to the atmosphere. Recover during system repair or final unit disposal.

Follow these steps to properly start up the system:

1. After system is evacuated, fully open liquid and vapor service valves.
2. Unit is shipped with valve stem(s) front seated (closed) and caps installed.

Replace stem caps after system is opened to refrigerant flow. Replace caps finger-tight and tighten with wrench an additional 1/12 turn

3. Close electrical disconnects to energize system.
4. Set room thermostat at desired temperature. Be sure set point is below indoor ambient temperature.
5. Set room thermostat to COOL and fan control to ON or AUTO mode, as desired. Operate unit for 15 minutes. Check system refrigerant charge.

Check Charge

Factory charge amount and desired subcooling are shown on unit rating plate. Charging method is shown on information plate inside unit. To properly check or adjust charge, conditions must be favorable for subcooling charging. Favorable conditions exist when the outdoor temperature is between 70°F and 100°F (21.11°C and 37.78°C), and the indoor temperature is between 70°F and 80°F (21.11°C and 26.67°C). Follow the procedure below:

Unit is factory charged for 15ft (4.57 m) of lineset. Adjust charge by adding or removing 0.6 oz/ft of 3/8 liquid line above or below 15ft (4.57 m) respectively.

For standard refrigerant line lengths (80 ft/24.38 m or less), allow system to operate in cooling mode at least 15 minutes. When operating with the Observer Wall Control in communicating mode, make sure that indoor airflow is set to "efficiency" during charging. If conditions are favorable, check system charge by subcooling method. If any adjustment is necessary, adjust charge slowly and allow system to operate for 15 minutes to stabilize before declaring a properly charged system.

If the indoor temperature is above 80°F (26.67°C), and the outdoor temperature is in the favorable range, adjust system charge by weight based on line length and allow the indoor temperature to drop to 80°F (26.67°C) before attempting to check system charge by subcooling method as described above.

If the indoor temperature is below 70°F (21.11°C), or the outdoor temperature is not in the favorable range, adjust charge for line set length above or below 15ft (4.57 m) only. Charge level should then be appropriate for the system to achieve rated capacity. The charge level could then be checked at another time when the both indoor and outdoor temperatures are in a more favorable range.

NOTE: If line length is beyond 80 ft (24.38 m) or greater than 20 ft (6.10 m) vertical separation, See Long Line Applications Guideline for special charging requirements.

Major Components

Control Board

The AC control board controls the following functions:

- Compressor contactor operation
- Outdoor fan motor operation
- Compressor external protection
- Pressure switch monitoring
- Time Delays

Field Connections

When using communicating control, 4 field wires are required to be connected to the factory wires already wired to the DX+DX- C R terminal (see Fig. 20). Unit as provided by manufacturer is set up for communicating control.

When used with a standard non-communicating thermostat, it is recommended to use 3 thermostat control wires to be connected to R, Y and C. When using 3 wires, all diagnostic and time delay features are enabled (See Fig. 21).

Disconnect factory provided wires from DX+, DX-, C & R terminals. Using factory provided wires, connect to R, C, and Y on the control board for 3 wire thermostat control. Connect field 24V wires to factory provided wires now connected to R, C, and Y and cap both sides or remove unused factory provided wires.

When only 2 thermostat control wires are available, units will function, but some control features are lost. (See Fig. 22). With only 2 wires connected, the circuit board will be powered down whenever there is no call for cooling, and the following will result:

- Compressor time delay is reduced from 5 minutes to 10 seconds
- When the thermostat is not calling for cooling, the amber status light will be off, and no diagnostics codes will be available
- All system counters will be reset on each new call for cooling

Disconnect factory provided wires from DX+, DX-, C and R terminals. Using factory provided wires, connect to C and Y on the control board for 2 wire thermostat control. A field installed jumper wire is also required between R and Y (See Fig. 22). Connect field 24V wires to factory provided wires now connected to C and Y and cap both sides or remove unused factory provided wires.

Compressor Internal Relief

The compressor is protected by an Internal Pressure Relief (IPR) which relieves discharge gas into the compressor shell when differential between suction and discharge pressure exceeds 550-625 psi. The compressor is also protected by an internal overload attached to motor windings.

GENERAL SEQUENCE OF OPERATION STANDARD THERMOSTAT

Turn on power to indoor and outdoor units. Transformer is energized.

On a call for cooling, thermostat makes circuits R- Y and R- G. Circuit R- Y energizes contactor, starting outdoor fan motor and compressor circuit. R- G energizes indoor unit blower relay, starting indoor blower motor on high speed.

NOTE: To achieve the rated system performance, the indoor unit or the thermostat must be equipped with a time delay relay circuit.

When thermostat is satisfied, its contacts open, de-energizing contactor and blower relay. Compressor and motors stop. If indoor unit is equipped with a time-delay relay circuit, the indoor blower will run an additional 90 sec to increase system efficiency.

CONTROL FUNCTIONS AND SEQUENCE OF OPERATION

The outdoor unit control system has special functions. The following is an overview of the control functions.

SEQUENCE OF OPERATION

Cooling Operation

This product utilizes either a standard indoor thermostat or Observer™ Communicating Wall Control. With a call for cooling, the outdoor fan and compressor are energized. When the cooling demand is satisfied, the compressor and fan will shut off.

NOTE: The outdoor fan motor will continue to operate for one minute after compressor shuts off, when the outdoor ambient is greater than or equal to 100°F (37.78°C).

Communication and Status Function Lights

Green Communications (COMM) Light (Communicating Control only):

A green LED (COMM light) on the outdoor board indicates successful communication with the other system products. The green LED will remain OFF until communications is established. Once a valid command is received, the green LED will turn ON continuously. If no communication is received within 2 minutes, the LED will be turned OFF until the next valid communication.

Amber Status Light

An amber colored STATUS light is used to display the operation mode and fault codes as specified in the troubleshooting section. See Table 1 for codes and definitions.

NOTE: Only one fault code will be displayed on the outdoor unit control board (the most recent, with the highest priority).

Crankcase Heater Operation

The crankcase heater (when applicable) is energized during the off cycle below 65°F (37.78°C)

Outdoor Fan motor Operation

The outdoor unit control energizes outdoor fan any time the compressor is operating. The outdoor fan remains energized for 15 minutes if a pressure switch or compressor thermal protector should open. Outdoor fan motor will continue to operate for one minute after the compressor shuts off when the outdoor ambient is greater than or equal to 100 °F (37.78°C).

Time Delays

The unit time delays include:

- Five minute time delay to start cooling operation when there is a call from the thermostat or communicating wall control.
- When operating the unit with 2 wires, this delay is shortened to 10 seconds.
- Five minute compressor recycle delay on return from a brown out condition
- Two minute time delay to return to standby operation from last valid communications (with communicating only)
- One minute time delay of outdoor fan at termination of cooling mode when outdoor ambient is greater than or equal to 100°F (37.78°C).

Utility Interface

With Non-Communicating Thermostats

Utility curtailment will only work when the unit is operating with a non-communicating thermostat.

When the utility curtailment interface is applied with a non-communicating thermostat, the utility relay should be wired in series with the Y input.

Low Ambient Cooling

With Non-Communicating Thermostats

When this unit is required to operate below 55°F (12.78°C) to a minimum of 0 °F (-17.78 °C) outdoor temperature, provisions must be made for low ambient operation.

Low ambient applications **require** the installation of accessory kits:

- Low Ambient Pressure Switch Kit
- Evaporator Freeze Thermostat
- Winter Start Control
- Hard Start kit
- Crankcase Heater

Support feet are recommended for low ambient cooling. See Product Specification sheet for kit part numbers on appropriate unit size and series unit.

For low ambient cooling with the Observer Communicating Wall Control the cooling lockout must be set to “Off” in the Wall Control setup.

Liquid Line Solenoid

When operating in communicating mode the standard thermostat terminals will not function. A terminal on the non-communicating thermostat bus labeled “LS” on the AC control board is provided for wiring liquid line solenoids when in communicating mode. For operation in communicating mode wire solenoid valve kit NASA401LS across LS and C terminals. For operation in non-communicating mode wire solenoid valve kit NASA401LS across C and Y terminals.

If the thermal cutout trips for three consecutive cycles, then unit operation is locked out for 4 hours and the appropriate fault code (See Table 1) is displayed.

CONTACTOR SHORTED DETECTION

If there is compressor voltage sensed when there is no demand for compressor operation, the contactor may be stuck closed. The control will flash the appropriate fault code. Check the contactor and control box wiring.

NO 230V AT COMPRESSOR

If the compressor voltage is not sensed when the compressor should be starting, the contactor may be stuck open or the unit disconnect or circuit breaker may be open. The control will flash the appropriate fault code. Check the contactor, unit disconnect or circuit breaker and control box wiring.

TEMPERATURE THERMISTORS

Thermistors are electronic devices which sense temperature. As the temperature increases, the resistance decreases. Thermistors are used to sense outdoor air (OAT) and coil temperature (OCT).

If the outdoor air or coil thermistor should fail, the control will flash the appropriate fault code. (See table 1).

IMPORTANT: The outdoor air thermistor and coil thermistor are factory mounted in the correct locations. Do not re-locate thermistor sensors.

THERMISTOR SENSOR COMPARISON

The control continuously monitors and compares the outdoor air temperature sensor and outdoor coil temperature sensor to ensure proper operating conditions. The comparison is, if the outdoor air sensor indicates $\geq 10^{\circ}\text{F}$ ($\geq -12.22^{\circ}\text{C}$) warmer than the coil sensor (or) the outdoor air sensor indicates $\geq 20^{\circ}\text{F}$ ($\geq -6.67^{\circ}\text{C}$) cooler than the coil sensor, the sensors are out of range.

If the sensors are out of range, the control will flash the appropriate fault code. (See Table 1).

FAILED THERMISTOR DEFAULT OPERATION

Factory defaults have been provided in the event of failure of outdoor air thermistor and/or coil thermistor.

Thermistor Curve: The resistance vs. temperature chart shown in Figure 18 enables the technician to check the outdoor air and outdoor coil thermistors for proper resistance. Unplug the thermistor assembly from the circuit board and measure resistance across each thermistor. For example, if the outdoor temperature is 60°F (15.56°C), the resistance reading across the outdoor air thermistor should be around 16,000 Ohms.

STATUS CODES

Table 3 shows the status codes flashed by the amber status light. Most system problems can be diagnosed by reading the status code as flashed by the amber status light on the control board.

The codes are flashed by a series of short and long flashes of the status light. The short flashes indicate the first digit in the status code, followed by long flashes indicating the second digit of the error code. The short flash is 0.25 second

ON and the long flash is 1.0 second ON. Time between flashes is 0.25 second. Time between short flash and first long flash is 1.0 second. Time between code repeating is 2.5 seconds with LED OFF.

Count the number of short and long flashes to determine the appropriate flash code. Table 1 gives possible causes and actions related to each error.

Example: 3 short flashes followed by 2 long flashes indicates a 32 code. Table 1 shows this to be low pressure switch open.

Table 1 - Status Codes

OPERATION	FAULT	AMBER LED FLASH CODE	Possible Cause and Action
Standby – no call for unit operation	None	On solid, no flash	Normal operation - with communicating Control
Standby – no call for unit operation	None	Off	Normal operation - No call for cooling with 2- wire connection or indoor unit not powered.
Cooling Operation	None	1, pause	Normal operation
	System Communications Failure	16	Communication with wall control lost. Check wiring to wall control, indoor and outdoor units
	High Pressure Switch Open	31	High pressure switch trip. Check refrigerant charge, outdoor fan operation and coils for airflow restrictions.
	Low Pressure Switch Open	32	Low pressure switch trip. Check refrigerant charge and indoor air flow
	Control Fault	45	Outdoor unit control board has failed. Control board needs to be replaced.
	Brown Out (24 v)	46	The control voltage is less than 15.5v for at least 4 seconds. Compressor and fan operation not allowed until control voltage is a minimum of 17.5v. Verify control voltage.
	Outdoor Air Temp Sensor Fault	53	Outdoor air sensor not reading or out of range. Ohm out sensor and check wiring
	Outdoor Coil Sensor Fault	55	Coil sensor not reading or out of range. Ohm out sensor and check wiring
	Thermistors out of range	56	Improper relationship between coil sensor and outdoor air sensor. Ohm out sensors and check wiring.
	Thermal Cutout	72	Compressor voltage sensed after start-up, then absent for 10 consecutive seconds while cooling demand exists. Possible causes are internal compressor overload trip or loss of high voltage to compressor without loss of control voltage. The control will continue fan operation and wait 15 minutes to attempt a restart. Fault will clear when restart is successful, or low voltage power is cycled.
	Contactors Shorted	73	Compressor voltage sensed when no demand for compressor operation exists. Contactor may be stuck closed or there is a wiring error.
	No 230V at Compressor	74	Compressor voltage not sensed when compressor should be starting. Disconnect may be open or contactor may be stuck open or there is a wiring error.
	Thermal Lockout	82	Thermal cutout occurs in three consecutive cycles. Unit operation locked out for 4 hours or until 24v power recycled.
	Low Pressure Lockout	83	Low pressure switch trip has occurred during 3 consecutive cycles. Unit operation locked out for 4 hours or until 24v power recycled.
	High Pressure Lockout	84	High pressure switch trip has occurred during 3 consecutive cycles. Unit operation locked out for 4 hours or until 24v power recycled.

Figure 18

Resistance vs Temperature Chart

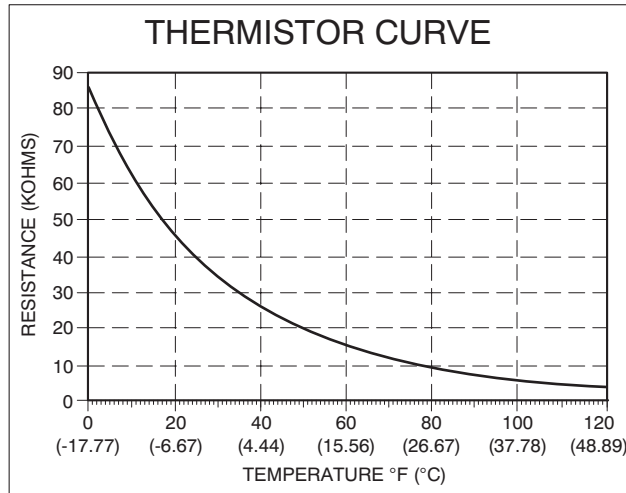

A08054

Figure 19

Single Stage Control Board (*4A3 only, sizes 24 & 30)

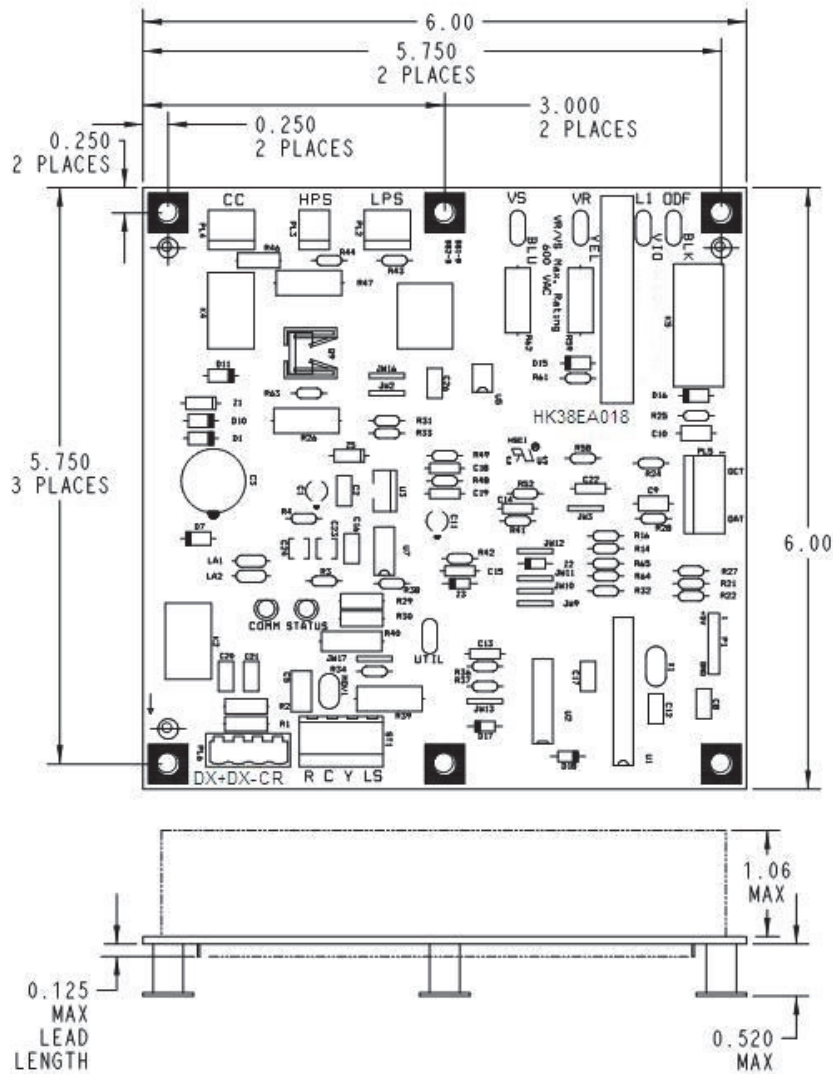

Figure 20

Observer Communicating Wall Control Four-Wire Connection Wiring Diagrams
(See Thermostat Installation Instructions for specific unit combinations)

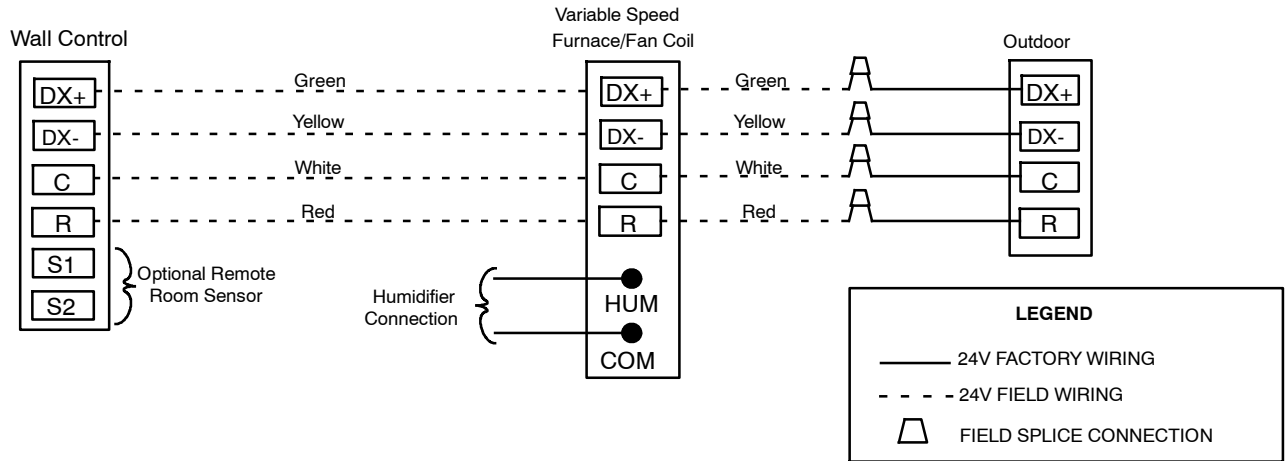
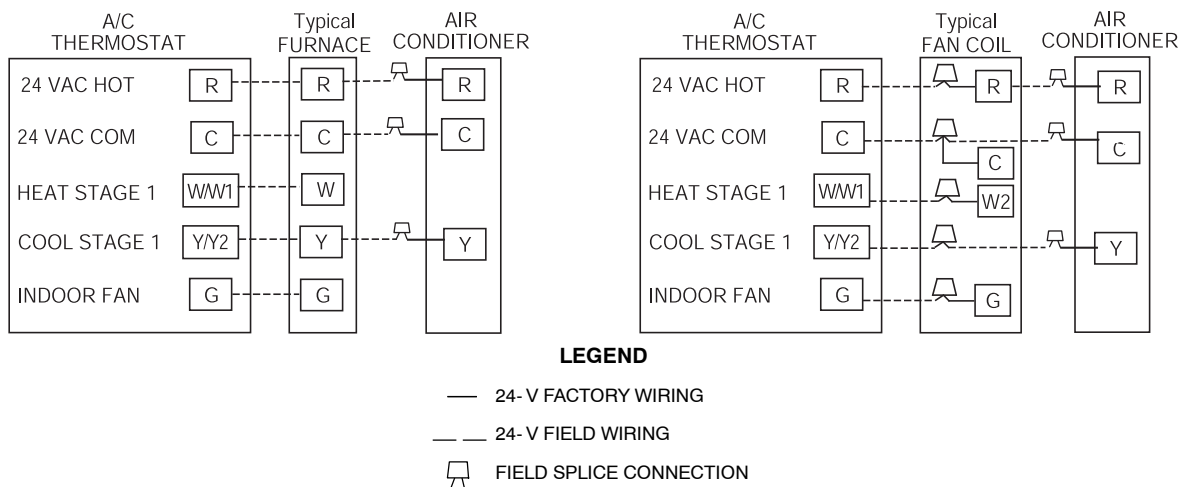

Figure 21

Non-Communicating Standard Thermostat 3-Wire 24V Circuit Connections
(See Thermostat Installation Instructions for Specific Unit combinations)



⚠ CAUTION

ELECTRICAL OPERATION HAZARD

Failure to follow this caution may result in equipment damage or improper operation.

A minimum of three wire thermostat wiring is required for the system to operate.

Figure 22

Non-Communicating Standard Thermostat
2-Wire 24V Circuit Connections

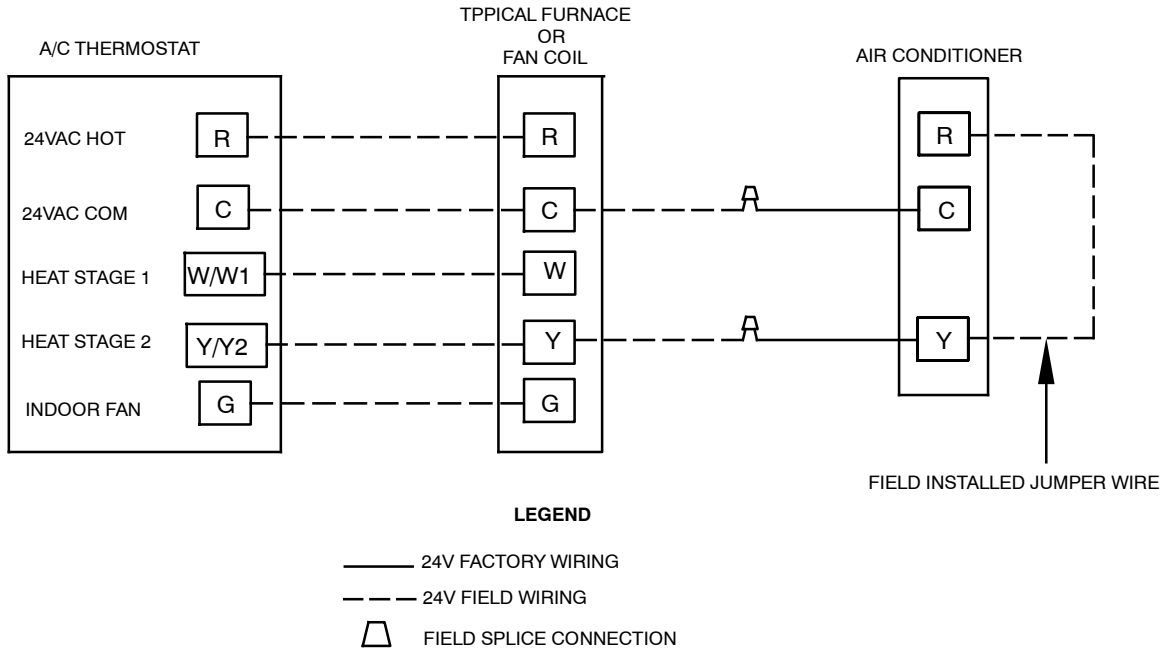

NOTE: Wiring must conform to NEC or local codes.

Figure 23

Non-Communicating Indoor with Observer Communicating Wall Control

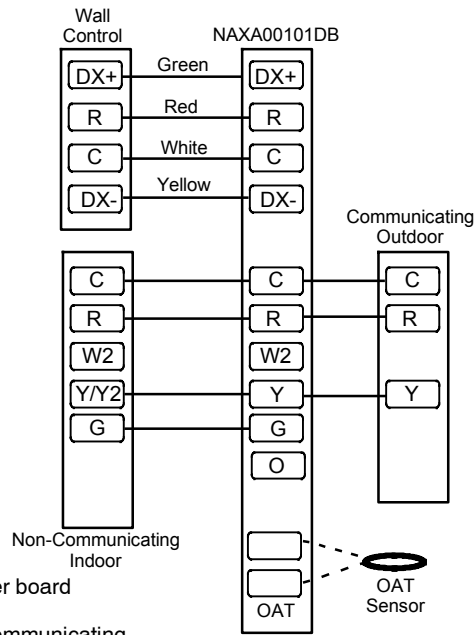

NOTE: This installation requires the daughter board accessory, NAXA00101DB.
 NOTE: This installation does not allow for communicating feature functionality.

R-410A QUICK REFERENCE GUIDE

- Observe all **WARNINGS, CAUTIONS, NOTES**, and **bold** text.
- R-410A refrigerant operates at 50% - 70% higher pressures than R-22. Be sure that servicing equipment and replacement components are designed to operate with R-410A.
- R-410A refrigerant cylinders are rose colored.
- Recovery cylinder service pressure rating must be 400 psig, DOT 4BA400 or DOT BW400.
- R-410A systems should be charged with liquid refrigerant. Use a commercial type metering device in the manifold hose.
- Manifold sets should be 750 psig high-side and 200 psig low-side with 520 psig low-side retard.
- Use hoses with 750 psig service pressure rating.
- Leak detectors should be designed to detect HFC refrigerant.
- R-410A, as with other HFC refrigerants, is only compatible with POE oils.
- Vacuum pumps will not remove moisture from oil.
- Do not use liquid line filter-driers with rated working pressures less than 600 psig.
- Do not install a suction line filter-drier in liquid line.
- POE oils absorb moisture rapidly. Do not expose oil to atmosphere.
- POE oils may cause damage to certain plastics and roofing materials.
- Wrap all filter-driers and service valves with wet cloth when brazing.
- A liquid line filter-drier is required on every unit.
- Do not use with an R-22 TXV.
- If indoor unit is equipped with an R-22 TXV, it must be changed to an R-410A TXV.
- Never open system to atmosphere while it is under a vacuum.
- When system must be opened for service, break vacuum with dry nitrogen and replace all filter-driers.
- Do not vent R-410A into the atmosphere.
- Do not use capillary tube indoor coils.