

# Operator's Manual

# CRAFTSMAN

## 10 IN. JOBSITE TABLE SAW

Model No. 137.054450

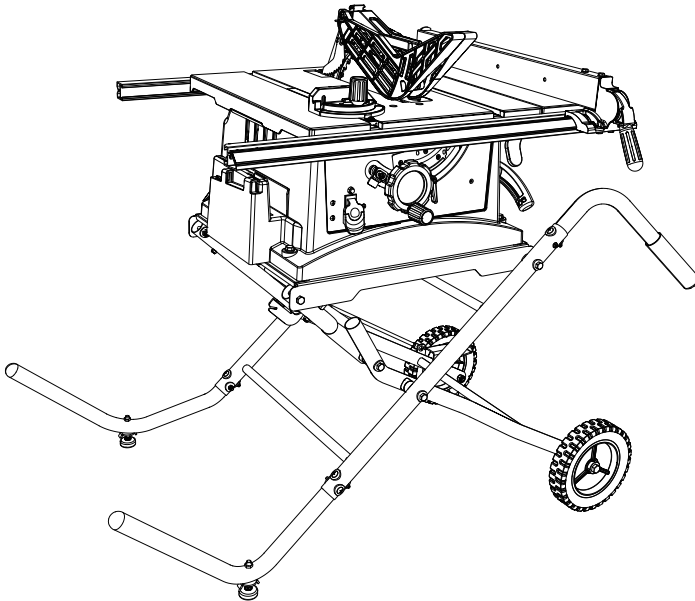

US  
174315

### CAUTION:

Before using this Table Saw, read this manual and follow all its Safety Rules and Operating Instructions

- Safety Instructions
- Assembly
- Operation
- Maintenance
- Parts List
- Español p. 61

**Customer Help Line  
For Technical Support  
1-800-843-1682**

**Sears Parts &  
Repair Center  
1-888-331-4569**

Sears Brands Management Corporation Hoffman Estates, IL 60179 USA

See the full line of Craftsman® products at [craftsman.com](http://craftsman.com)

Click on the Craftsman Club® link and join today!

Part No. 137054450001

Printed in China

# TABLE OF CONTENTS

SECTION	PAGE
Warranty .....	2
Product Specifications .....	3
Symbols.....	4
Power Tool Safety .....	5
Table Saw Safety .....	8
Electrical Requirements and Safety .....	12
Accessories and Attachments .....	14
Tools Needed .....	14
Carton Contents .....	15
Know Your Table Saw .....	17
Glossary of Terms .....	18
Assembly .....	20
Adjustment .....	29
Operation .....	36
Maintenance .....	47
Troubleshooting Guide .....	50
Parts List .....	53
Repair Protection Agreement .....	58

## WARRANTY

### CRAFTSMAN LIMITED WARRANTY

FOR ONE YEAR from the date of sale this product is warranted against defects in material or workmanship. WITH PROOF OF SALE, a defective product will receive free repair or replacement at option of seller. For warranty coverage details to obtain free repair or replacement, visit the web page: [www.craftsman.com/warranty](http://www.craftsman.com/warranty)

This warranty does not cover the blade, which is an expendable part that can wear out from normal use within the warranty period. This ONE YEAR warranty is void if this product is ever used while providing commercial services or if rented to another person. For 90 DAY commercial and rental terms, see the Craftsman warranty web page. This warranty gives you specific legal rights, and you may also have other rights which vary from state to state.

**Sears Brands Management Corporation, Hoffman Estates, IL 60179**

### CALIFORNIA PROPOSITION 65

#### WARNING

Some dust created by power sanding, sawing, grinding, drilling and other construction activities contains chemicals known to the state of California to cause cancer, birth defects or other reproductive harm. Some examples of these chemicals are:

- Lead from lead-based paints,
- Crystalline silica from bricks, cement and other masonry products, and
- Arsenic and chromium from chemically treated lumber.

Your risk from these exposures varies, depending on how often you do this type of work. To reduce your exposure to these chemicals: work in a well ventilated area, and work with approved safety equipment, such as those dust masks that are specially designed to filter out microscopic particles. Avoid prolonged contact with dust from power sanding, sawing, grinding, drilling, and other construction activities. Wear protective clothing and wash exposed areas with soap and water. Allowing dust to get into your mouth, eyes, or lay on the skin may promote absorption of harmful chemicals.

# PRODUCT SPECIFICATIONS

## MOTOR

Type.....	Universal
Ampere.....	15.0 Amps
Voltage.....	120 V AC
Hz.....	60 Hz
RPM (no load) .....	5000 RPM (No load)
Overload Protection.....	Yes

## BLADE SIZE

Diameter.....	10 in.
Arbor Size.....	5/8 in.

## SAW

Rip Capacity .....	24 in. Right
Maximum Cut Depth @ 90° .....	3 in.
Maximum Cut Depth @ 45° .....	2-1/2 in.
Maximum Diameter Dado .....	6 in. (Stackable only)
Maximum Dado Cut Width .....	1/2 in.

## WARNING

**To avoid electrical hazards, fire hazards or damage to the tool, use proper circuit protection. This tool is wired at the factory for 120 Volt operation. It must be connected to a 120 Volt / 15 Ampere time delay fuse or circuit breaker. To avoid shock or fire, replace power cord immediately if it is worn, cut or damaged in any way. Before using your tool, it is critical that you read and understand these safety rules. Failure to follow these rules could result in serious injury to you or damage to the tool.**

**PLEASE READ THE FOLLOWING:** The manufacturer and/or distributor is providing the buyer with a parts list and assembly diagram in this manual as a reference tool only. Neither the manufacturer nor distributor make any representation or warranty of any kind to the buyer regarding the accuracy of the list or diagram or that buyer is qualified and able to make any repairs or replace any parts of the product. The manufacturer and/or distributor expressly recommend: that all repairs and/or part replacements only be undertaken by a certified and licensed technician, and not by the buyer. The buyer assumes all risk and liability, including injuries to persons and damage to property, associated with and arising out of any attempt of the buyer at repairs or replacement of parts to the product.

# SYMBOLS

## WARNING ICONS

Your power tool and its Operator's Manual may contain "WARNING ICONS" (a picture symbol intended to alert you to, and/or instruct you how to avoid, a potentially hazardous condition). Understanding and heeding these symbols will help you operate your tool better and safer. Shown below are some of the symbols you may see.



**SAFETY ALERT:** Precautions that involve your safety.



**PROHIBITION**



**WEAR EYE PROTECTION:** Always wear safety goggles or safety glasses with side shields.



**WEAR RESPIRATORY AND HEARING PROTECTION:** Always wear respiratory and hearing protection.



**READ AND UNDERSTAND INSTRUCTION MANUAL:** To reduce the risk of injury, user and all bystanders must read and understand instruction manual before using this product.



**KEEP HANDS AWAY FROM BLADE:** Failure to keep your hands away from the blade will result in serious personal injury.



**SUPPORT AND CLAMP WORK**



**DANGER:** indicates an imminently hazardous situation which, if not avoided, will result in death or serious injury.



**WARNING:** indicates a potentially hazardous situation which, if not avoided, could result in death or serious injury.



**CAUTION:** indicates a potentially hazardous situation which, if not avoided, may result in minor or moderate injury.



**CAUTION:** used without the safety alert symbol indicates a potentially hazardous situation which, if not avoided, may result in property damage.

# POWER TOOL SAFETY

## GENERAL SAFETY INSTRUCTIONS BEFORE USING THIS POWER TOOL



Safety is a combination of common sense, staying alert and knowing how to use your power tool.

### **WARNING**

- **To avoid mistakes that could cause serious injury, do not plug the tool in until you have read and understood the following.**
- **Read all instructions before operating product. Failure to follow all instructions listed below may result in electric shock, fire and/or serious injury.**

1.  **READ** and become familiar with the entire Operator's Manual. **LEARN** the tool's application, limitations and possible hazards.
2. **KEEP GUARDS IN PLACE** and in working order.
3. **REMOVE ADJUSTING KEYS AND WRENCHES.** Form the habit of checking to see that keys and adjusting wrenches are removed from the tool before turning ON.
4. **KEEP WORK AREA CLEAN.** Cluttered areas and benches invite accidents.

5. **DO NOT USE IN DANGEROUS ENVIRONMENTS.** Do not use power tools in damp locations, or expose them to rain or snow. Keep work area well lit.
6. **KEEP CHILDREN AWAY.** All visitors and bystanders should be kept a safe distance from work area.
7. **MAKE WORKSHOP CHILD PROOF** with padlocks, master switches or by removing starter keys.
8. **DO NOT FORCE THE TOOL.** It will do the job better and safer at the rate for which it was designed.
9. **USE THE RIGHT TOOL.** Do not force the tool or an attachment to do a job for which it was not designed.
10. **USE PROPER EXTENSION CORDS.** Make sure your extension cord is in good condition. When using an extension cord, be sure to use the one heavy enough to carry the current that the product will draw. An undersized cord will result in a drop in line voltage and in loss of power which will cause the tool overheat. The table on page 13 shows the proper wire gauge size usage to each extension cord length and ampere rating. If in doubt, use the next heavier gauge. The smaller the gauge number, the heavier the cord.

11. **WEAR PROPER APPAREL.** Do not wear loose clothing, gloves, neckties, rings, bracelets or other jewelry which may get caught in moving parts. Nonslip footwear is recommended. Wear protective hair covering to contain long hair.
12.  **ALWAYS WEAR EYE PROTECTION.** Any power tool can throw foreign objects into the eyes and could cause permanent eye damage. **ALWAYS** wear Safety Goggles (not glasses) that comply with ANSI Safety standard Z87.1. Everyday eyeglasses have only impact-resistant lenses. They **ARE NOT** safety glasses. Safety Goggles are available at Sears. **NOTE:** Glasses or goggles not in compliance with ANSI Z87.1 could seriously injure you when they break.
13.  **WEAR A FACE MASK OR DUST MASK.** Sawing operation produces dust.
14.  **SECURE WORK.** Use clamps or a vice to hold work when practical. It is safer than using your hand and it frees both hands to operate the tool.
15. **DISCONNECT TOOLS FROM POWER SOURCE** before servicing, and when changing accessories such as blades, bits and cutters.
16. **REDUCE THE RISK OF UNINTENTIONAL STARTING.** Make sure switch is in the OFF position before plugging the tool in.
17. **USE RECOMMENDED ACCESSORIES.** Consult this Operator's Manual for recommended accessories. The use of improper accessories may cause risk of injury to yourself or others.
18. **NEVER STAND ON THE TOOL.** Serious injury could occur if the tool is tipped or if the cutting tool is unintentionally contacted.
19. **CHECK FOR DAMAGED PARTS.** Before further use of the tool, a guard or other part that is damaged should be carefully checked to determine that it will operate properly and perform its intended function – check for alignment of moving parts, binding of moving parts, breakage of parts, mounting and any other conditions that may affect its operation. A guard or other part that is damaged should be properly repaired or replaced.
20. **NEVER LEAVE THE TOOL RUNNING UNATTENDED. TURN THE POWER "OFF".** Do not walk away from a running tool until the blade comes to a complete stop and the tool is unplugged from the power source.

21. **DO NOT OVERREACH.** Keep proper footing and balance at all times. NEVER reach across the path of the cutting blade while tool is in operation.

22. **MAINTAIN TOOLS WITH CARE.**

Keep tools sharp and clean for best and safest performance. Follow instructions for lubricating and changing accessories.

23. **DO NOT** use power tool in presence of flammable liquids or gases.

24. **DO NOT** operate the tool if you are under the influence of any drugs, alcohol or medication that could affect your ability to use the tool properly.

25.  **WARNING** Dust generated from certain materials can be hazardous to your health. Always operate saw in well-ventilated area and provide for proper dust removal.

26.  **WARNING** People with electronic devices, such as pacemakers, should consult their physician(s) before using this product. Operation of electrical equipment in close proximity to a heart pacemaker could cause interference or failure of the pacemaker.

27.  **WEAR HEARING PROTECTION** to reduce the risk of induced hearing loss.

# TABLE SAW SAFETY



- 1. ALWAYS USE SAW BLADE GUARD**, riving knife and anti-kickback pawls assembly for every through-sawing operation. Through-sawing operations are those in which the blade cuts completely through the workpiece when ripping or crosscutting. Always be sure blade guard is tightened securely.
- 2. ALWAYS HOLD WORKPIECE FIRMLY** against the miter gauge or rip fence. Use rip fence for rip cuts and miter gauge for crosscuts. Never use miter gauge and rip fence simultaneously.
- 3. ALWAYS USE** a push stick or push block, especially when ripping narrow stock. Refer to ripping instructions in this Operator's Manual where the push stick is covered in detail. A pattern for making your own push stick is included on page 52.
- 4. NEVER PERFORM ANY OPERATION FREEHAND**, which means only using hands to support or guide the workpiece. Always use either the rip fence or miter gauge to position and guide the work.
- 5. NEVER STAND** or have any part of your body in line with the path of the saw blade. Keep your hands out of the saw blade path.
- 6. NEVER REACH** behind or over the cutting tool for any reason.
- 7. REMOVE** the rip fence when crosscutting.
- 8. DO NOT USE** a molding head with this saw.
- 9. DIRECTION OF FEED.** Feed work into a blade against the direction of rotation of the blade.
- 10. NEVER** use the rip fence as a cut-off gauge when crosscutting.
- 11. NEVER ATTEMPT TO FREE A STALLED SAW BLADE** without first turning the saw OFF. Turn power switch OFF immediately to prevent motor damage.
- 12. PROVIDE ADEQUATE SUPPORT** to the rear and the sides of the saw table for long or wide workpieces.
- 13. AVOID KICKBACKS** (work thrown back towards you) by keeping the blade sharp, the rip fence parallel to the saw blade and by keeping the riving knife, anti-kickback pawls assembly and guards in place, aligned and functioning. Do not release work before passing it completely beyond the saw blade. Do not rip work that is twisted, warped or does not have a straight

## **WARNING**

**FREEHAND CUTTING IS THE MAJOR CAUSE OF KICKBACK AND FINGER/HAND AMPUTATIONS. NEVER USE THE MITER GAUGE AND FENCE SIMULTANEOUSLY.**

**5. NEVER STAND** or have any part of your body in line with the path of the



- edge to guide it along the fence.  
Do not attempt to reverse out of a cut with the blade running.
14. **AVOID AWKWARD OPERATIONS** and hand positions where a sudden slip could cause your hand to move into the saw blade.
15. **NEVER USE SOLVENTS** to clean plastic parts. Solvents could possibly dissolve or otherwise damage the material. Only a soft damp cloth should be used to clean plastic parts.
16. **MOUNT** your table saw on a bench or stand before performing any cutting operations. Refer to **ASSEMBLY** on page 20. Secure tool properly to prevent unexpected movement.
17.  **WARNING**  
Never cut metals or masonry products with this tool. This table saw is designed for use on wood and wood-like products only.
18. **ALWAYS USE IN A WELL-VENTILATED AREA.** Remove sawdust frequently. Clean out sawdust from the interior of the saw to prevent a potential fire hazard. Attach a vacuum to the dust port for additional sawdust removal.
19. **NEVER LEAVE THE SAW RUNNING UNATTENDED.** Do not leave the saw until the blade comes to a complete stop.
20. For proper operation follow the instructions in this Operator's Manual entitled **ASSEMBLY AND ADJUSTMENTS** (Page 20). Failure to provide sawdust fall-through and removal hole will allow sawdust to build up in the motor area resulting in a fire hazard and potential motor damage.
21. **USE ONLY** saw blades recommended with the warning that the riving knife shall not be thicker than the width of the groove cut by the saw blade and not thinner than the body of the saw blade.
22. **USE PUSH STICK OR PUSH BLOCK** to feed the workpiece past the saw blade. The push stick or push block should always be stored with the machine when not in use.
23.  **WARNING**  
**DO NOT RESAW** material with this saw.
24. **DO NOT USE** this saw to cut tree limbs or logs

# TABLE SAW SAFETY

## **SAW BLADE GUARD ASSEMBLY, ANTI-KICKBACK ASSEMBLY AND RIVING KNIFE**

Your table saw is equipped with a blade guard assembly, anti-kickback assembly and riving knife that covers the blade and reduces the possibility of accidental blade contact. The riving knife is a flat plate that fits into the cut made by the saw blade and effectively fights kickback by lessening the tendency of the blade to bind in the cut. The blade guard assembly and anti-kickback assembly can only be used when making through cuts that sever the wood. When making rabbets and other cuts that make non-through cuts, the blade guard assembly and anti-kickback assembly must be removed and riving knife lowered to the non-through cut position marked on the riving knife. Two anti-kickback pawls are located on the sides of the riving knife that allow the wood to pass through the blade in the cutting direction but reduce the possibility of the material being thrown backwards toward the operator. Use all components of the guarding system (blade guard assembly, riving knife and anti-kickback assembly) for every operation for which they can be used including all through cutting. If you elect not to use any of these components for a particular application exercise additional caution regarding control of the workpiece, the use of push sticks, the position of your hands relative to the blade, the use of safety

glasses, the means to avoid kickback and all other warnings contained in this manual and on the saw itself. Replace the guarding systems as soon as you return to through-cutting operations. Keep the guard assembly in working order.

## **KICKBACKS**

**KICKBACKS:** Kickbacks can cause serious injury. A kickback occurs when a part of the workpiece binds between the saw blade and the rip fence, or other fixed object, and rises from the table and is thrown toward the operator. Kickbacks can be avoided by attention to the following conditions.

### **How to Avoid Kickbacks and Protect Yourself from Possible Injury:**

- a. Be certain that the rip fence is parallel to the saw blade.
- b. Do not rip by applying the feed force to the section of the workpiece that will become the cut-off (free) piece. Feed force when ripping should always be applied between the saw blade and the fence; use a push stick for narrow work, 6 in. (152 mm) wide or less.
- c. Keep saw blade guard assembly, riving knife and anti-kickback assembly in place and operating properly. If anti-kickback assembly is not operational, return your unit to the nearest Sears or other qualified service dealer for repair. The riving knife must be in alignment with the saw blade and the

anti-kickback pawls assembly must stop a kickback once it has started. Check their action before ripping by pushing the wood under the anti-kickback assembly. The teeth must prevent the wood from being pulled toward the front of the saw.

- d. Use saw blade guard assembly, anti-kickback pawls assembly and riving knife for every operation for which it can be used, including all through-sawing.
- e. Push the workpiece past the saw blade prior to release.
- f. Never rip a workpiece that is twisted or warped, or does not have a straight edge to guide along the fence.
- g. Never saw a large workpiece that cannot be controlled.
- h. Never use the fence as a guide or length stop when crosscutting.
- i. Never saw a workpiece with loose knots, flaws, nails or other foreign objects.
- j. Never rip a workpiece shorter than 10 in. (254 mm).
- k. NEVER use a dull blade – replace or have resharpened.
- l. NEVER use a rip fence and miter gauge together.
- m. Keep hands out of saw blade.

# ELECTRICAL REQUIREMENTS AND SAFETY

## POWER SUPPLY AND MOTOR SPECIFICATIONS

### **WARNING**

To avoid electrical hazards, fire hazards, or damage to the tool, use proper circuit protection. Use a separate electrical circuit for your tool. Your table saw is wired at the factory for 120 V operation. Connect to a 120 V, 15 Amp circuit and use a 15 Amp time delay fuse or circuit breaker. To avoid shock or fire, if power cord is worn, cut, or damaged in any way, have it replaced immediately.

## GROUNDING INSTRUCTIONS

### **WARNING**

This tool must be grounded while in use to protect the operator from electrical shock.

**IN THE EVENT OF A MALFUNCTION OR BREAKDOWN**, grounding provides a path of least resistance for electric currents and reduces the risk of electric shock. This tool is equipped with an electrical cord that has an equipment grounding conductor and a grounding plug. The plug must be plugged into a matching receptacle that is properly installed and grounded in accordance with all local codes and ordinances.

**DO NOT MODIFY THE PLUG PROVIDED.** If it will not fit the receptacle, have the proper receptacle installed by a qualified electrician.

**IMPROPER CONNECTION** of the equipment grounding conductor wire can result in risk of electric shock. The conductor with the green insulation (with or without yellow stripes) is the equipment grounding conductor. If repair or replacement of the electrical cord or plug is necessary, do not connect the equipment grounding conductor to a live terminal.

**CHECK** with a qualified electrician or service person if you do not completely understand the grounding instructions, or if you are not certain the tool is properly grounded.

**USE only 3-wire extension cords that have three-pronged grounding plugs with three-pole receptacles that accept the tool's plug. Repair or replace damaged or worn cords immediately.**

Use a separate electrical circuit for your tool. This circuit must not be less than # 14 wire and should be protected with a 15 Amp time delay fuse. Before connecting the motor to the power line, make sure the switch is in the off position and the electric current is rated the same as the current stamped on the motor nameplate. Running at a lower voltage will damage the motor.

**USE THE PROPER EXTENSION CORD.** Make sure your extension cord is in good condition. Use an extension cord heavy enough to carry the current your product will draw. An undersized cord will cause a drop in line voltage resulting in loss of power,

overheating and burning out of the motor. The table below shows the correct size to use depending on cord length and nameplate ampere rating. If in doubt, use the next heavier gauge. The smaller the gauge number, the heavier the cord.

**GUIDELINES FOR EXTENSION CORDS**

Make sure your extension cord is properly wired and in good condition. Always replace a damaged extension cord or have it repaired by a qualified technician before using it. Protect your extension cords from sharp objects, excessive heat and damp or wet areas.

MINIMUM GAUGE FOR EXTENSION CORDS (AWG)					
(When using 120 volts only)					
Ampere Rating		Total length of Cord			
More Than	Not More Than	25ft. (7.62 m)	50ft. 15.24 m	100ft. 30.48 m	150 ft. 45.72 m
		AWG- American Wire Gauge			
0	6	18	16	16	14
6	10	18	16	14	12
10	12	16	16	14	12
12	16	14	12	Not Recommended	

**WARNING**

This tool is for indoor use only. Do not expose to rain or use in damp locations.

This tool is intended for use on a circuit that has a receptacle like the one illustrated in Fig. 1. Fig. 1 shows a three-pronged electrical plug and receptacle that has a grounding conductor. If a properly grounded receptacle is not available, an adapter (Fig. 2) can be used to temporarily connect this plug to a two-contact grounded receptacle.

The adapter (Fig. 2) has a grounding lug extending from it that MUST be connected to a permanent earth ground, such as a properly grounded receptacle box.

**CAUTION**

In all cases, make certain the receptacle is properly grounded. If you are not sure, have a qualified electrician check the receptacle.

**Fig. 1**

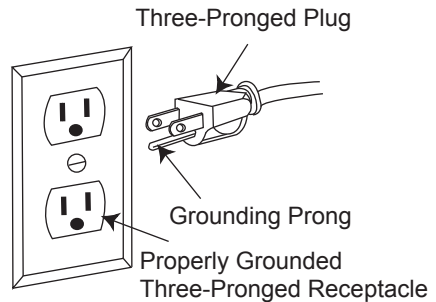

**Fig. 2**

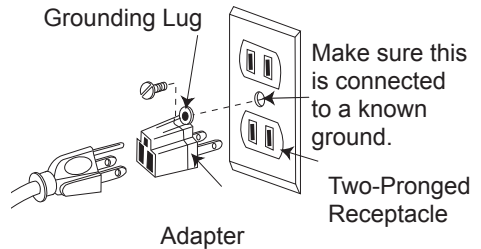

## ACCESSORIES AND ATTACHMENTS

### RECOMMENDED ACCESSORIES

#### WARNING

Visit your Sears Hardware Department or [www.sears.com](http://www.sears.com) to purchase recommended accessories for this power tool.

2YTV DADO INSERT PLATE

#### WARNING

To avoid the risk of personal injury:

- Do not use adjustable (wobble) type dados or carbide tipped dado blades.
- Only use stackable dados.
- Maximum dado width is 1/2 in.
- Do not use a dado with a diameter larger than 6 in.
- Do not use molding head set with this saw.
- Do not modify this power tool or use accessories not recommended by Sears.

## TOOLS NEEDED TO INSTALL BLADE

### SUPPLIED



Box-end wrench



Open-end wrench

## TOOLS NEEDED FOR OTHER ASSEMBLY

### NOT SUPPLIED



Flat bladed screwdriver



Two (2) adjustable wrenches



#2 Phillips screwdriver

## TOOLS NEEDED FOR ADJUSTMENT

### SUPPLIED



4 mm hex wrench

### NOT SUPPLIED



5 mm hex wrench



Combination square

# CARTON CONTENTS

Separate all parts from packing materials. Check each part with the illustration on the next page and the “Table of Loose Parts” to make certain all items are accounted for, before discarding any packing material.

**NOTE:** To make assembly easier, keep contents of box together.

## **WARNING**

If any part is missing or damaged, do not attempt to assemble the table saw, or plug in the power

cord until the missing or damaged part is correctly replaced. Call 1-800-843-1682 for missing or damaged part replacement. To avoid electric shock, use only identical replacement parts when servicing double insulated tools. Call 1-888-331-4569 for replacement parts. The manufacturer and/or distributor expressly recommend that all repairs and/or part replacements only be undertaken by a certified and licensed technician, and not the buyer.

## TABLE OF LOOSE PARTS

ITEM	DESCRIPTION	QUANTITY
A	Table saw assembly	1
B	Blade guard assembly	1
C	Anti-kickback pawls assembly	1
D	Riving knife assembly hardware bag	1
E	Rip fence	1
F	Miter gauge	1
G	Blade wrenches	2
H	Push stick	1
I	Push stick storage bracket	1
J	4 mm hex wrench	1
K	Blade	1
L	Handwheel handle	1
M	Power cord storage	1
N	Table saw mounting hardware bag	4

## STAND

O	Front stand legs	2
P	Front stand leg hardware bag	1
Q	Stand handle hardware bag	1
R	Wheel hardware assembly	1
S	Stand assembly	1

# UNPACKING YOUR TABLE SAW

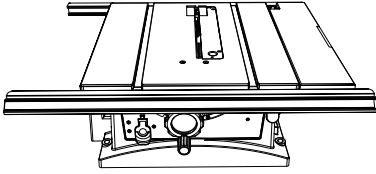

A



B



C

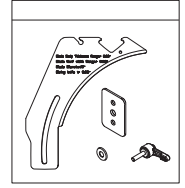

D

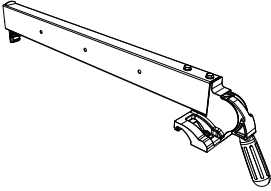

E

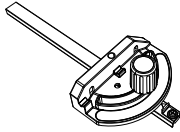

F



G

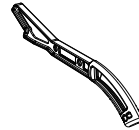

H



I



J

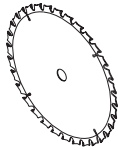

K



L

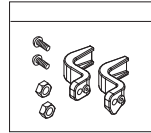

M

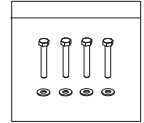

N



O

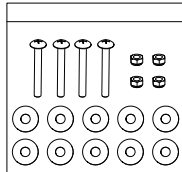

P

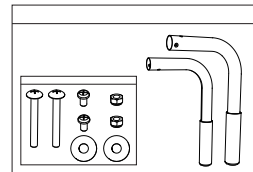

Q

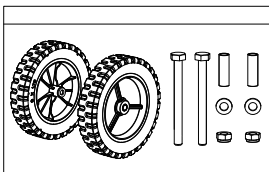

R

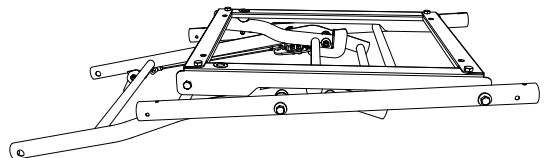

S



# KNOW YOUR TABLE SAW

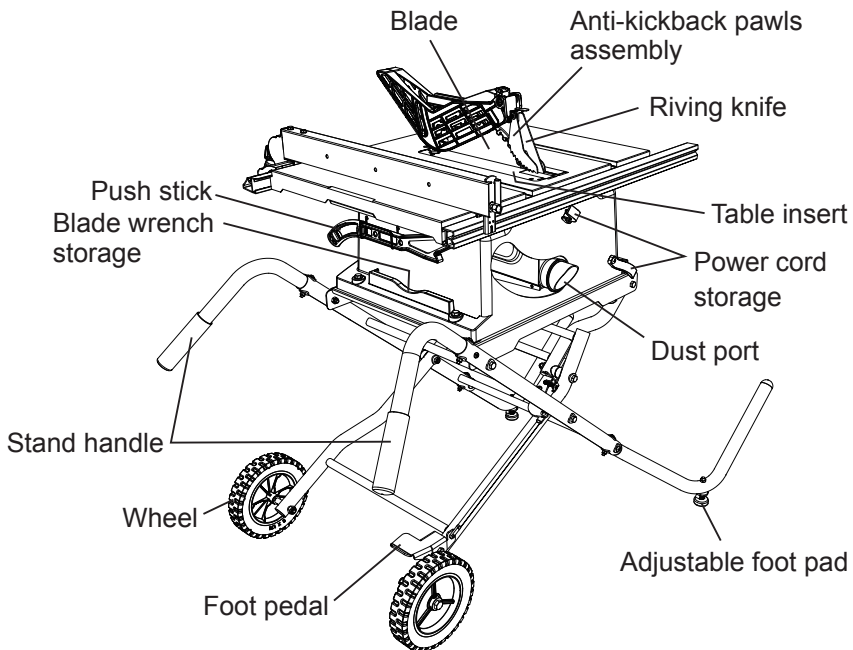
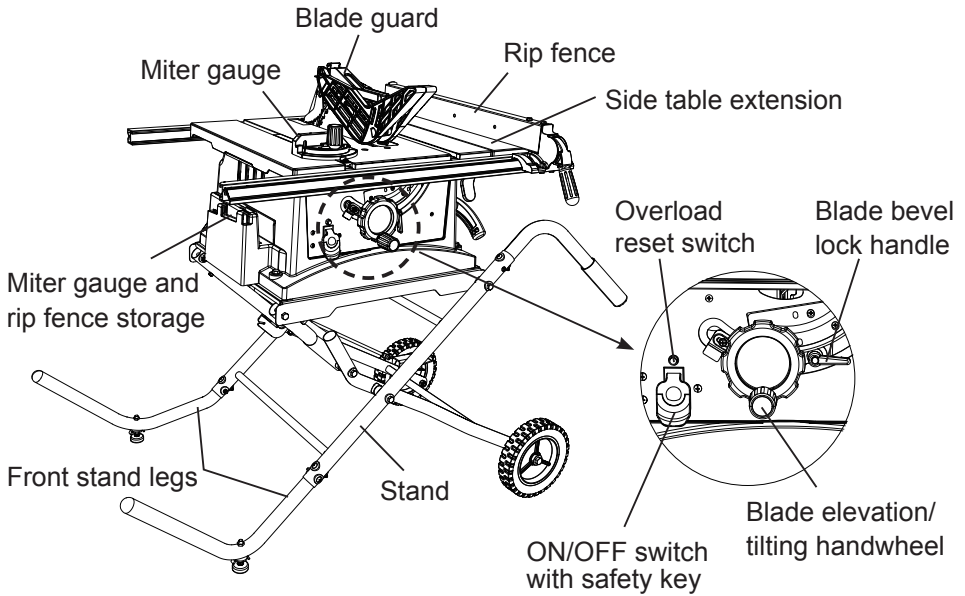

# GLOSSARY OF TERMS

## **ANTI-KICKBACK PAWLS ASSEMBLY**

– Prevents the workpiece from being kicked upward or back toward the front of the table saw by the spinning blade.

**ARBOR** – The shaft on which the blade or dado blade is mounted.

**BEVEL CUT** – An angle cut made through the face of the workpiece.

**BLADE BEVEL SCALE** – Measures the angle the blade is tilted when set for a bevel cut.

## **BLADE ELEVATION/TILTING**

**HANDWHEEL** – Raises and lowers the blade or tilts the blade to angle between 0° and 45° for bevel cuts.

**BLADE GUARD** – Clear plastic cover that positions itself over the blade while cutting.

**COMPOUND CUT** – A simultaneous bevel and miter cut.

**CROSSCUT** – A cut made across the width of the workpiece.

**DADO** – Special cutting blades that are used to cut grooves in a workpiece.

**FEATHERBOARD** – When ripping a workpiece on your table saw, this keeps it firmly and safely against the rip fence. It also helps prevent chatter, gouging, and dangerous kickback.

**FREEHAND** – Performing a cut without using a rip fence, miter gauge, hold down or other proper device to prevent the workpiece from twisting during the cutting operation.

**GUM** – A sticky sap from wood products.

**HEEL** – Misalignment of the blade.

**JAMB NUT** – Nut used to lock another nut in place on a threaded rod or bolt.

**KERF** – The amount of material removed by the blade cut.

**KICKBACK** – Occurs when the saw blade binds in the cut and violently thrusts the workpiece back toward the operator.

**MITER CUT** – An angle cut made across the width of the workpiece.

**MITER GAUGE** – A guide used for crosscutting operations that slides in the table top channels (grooves) located on either side of the blade. It helps make accurate straight or angle crosscuts.

**NON-THROUGH SAWING** – Refers to any cut that does not completely cut through the workpiece.

**OVERLOAD RESET SWITCH –**

Protects the motor if it overloads during operation, provides a way to restart the saw.

**PUSH STICK –** Used to push workpieces when performing ripping operations.

**PUSH BLOCK –** Used for ripping operation when the workpiece is too narrow to use a push stick. Always use a push block for rip widths less than 2 in. (50.8 mm).

**RESAWING –** Flipping material to make a cut the saw is not capable of making in one pass.

**⚠ WARNING**

**Do not resaw material with this saw.**

**REVOLUTIONS PER MINUTE (RPM)**

– The number of turns completed by a spinning object in one minute.

**RIP FENCE –** A guide used for rip cutting which allows the workpiece to cut straight.

**RIPPING –** Cutting with the grain of the wood or along the length of the workpiece.

**RIVING KNIFE –** A metal piece of the guard assembly located behind and in-line with the blade. Slightly thinner

than the saw blade, it helps keep the kerf open and prevents kickback.

**SAW BLADE PATH –** The area of the workpiece or table top directly in line with the travel of the blade or the part of the workpiece that will be cut.

**SET –** The distance between two saw blade tips, bent outward in opposite directions to each other. The further apart the tips are, the greater the set.

**TABLE INSERT –** Insert that is removed from the table to install / remove blades. When dado cutting, a dado insert plate must be used.

**THROUGH SAWING –** Making a cut completely through the length or width of a workpiece.

**WORKPIECE –** Material to be cut.

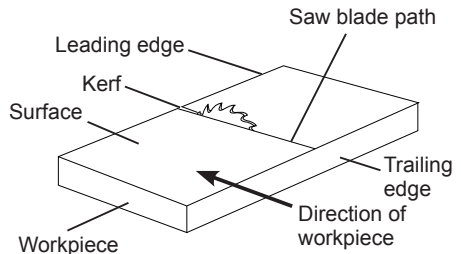

**NOTE:** Blade guard assembly is removed for purposes of illustration only.

# ASSEMBLY

## **⚠ WARNING**

For your safety, never connect plug to power source receptacle until all assembly and adjustment steps are complete, and you have read and understood the safety instructions.

### ASSEMBLING THE STAND LEGS TO STAND (FIG. A, B)

1. Insert one front stand leg (1) into one side of the stand assembly using two bolts (2), four washers (3) and two nuts (4).
2. Insert the other front stand leg (5) into the other side of the stand assembly in the same manner.

**NOTE:** The bent parts of the stand legs (1, 5) should point outward in opposite directions from each other.

3. Tighten using an adjustable wrench for the nuts (4) and a Phillips screwdriver for the bolts (2).

**NOTE:** This adjustable foot pad is used to level the saw. Loosen the wing nut (6), turn the adjustable foot pad (7) clockwise to raise and counterclockwise to lower the stand, then tighten the wing nut (6). (Fig. B)

**Fig. A**

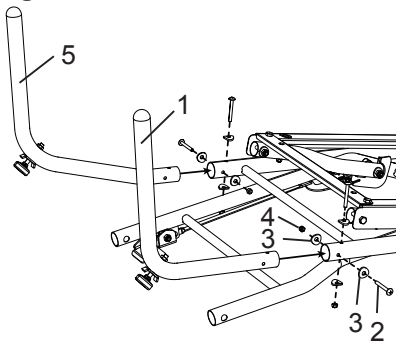

**Fig. B**

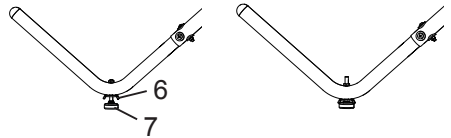

Raise the stand

Lower the stand

### ASSEMBLING THE ROLLER WHEELS TO STAND (FIG. C)

1. Attach one wheel (1) to the outer side of the stand wheel leg using the hex bolt (2), the sleeve (3), the flat washer (4) and the nut (5).

**NOTE:** Verify that the side of the wheel that has the most ribs (6) is facing toward the stand as shown.

2. Tighten using two adjustable wrenches for the nut and bolt.

**NOTE:** Do not overtighten. Doing so will not allow the wheels to turn properly.

3. Repeat the above steps for the other wheel.

**Fig. C**

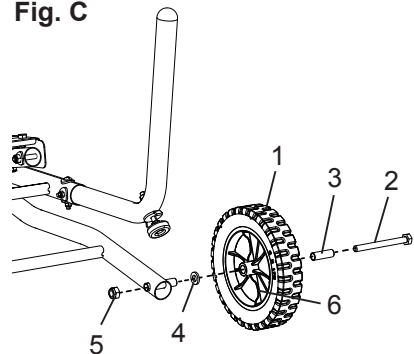

## ASSEMBLING THE STAND HANDLES TO STAND (FIG. D)

1. Place stand upside down on level surface or floor.
2. Insert one stand handle (1) into one stand tube and align the holes on the handle and tube.

**NOTE:** The bent parts of the stand handles (1, 2) should point outward in opposite directions from each other.

3. Insert one short screw (3), one long screw (4), two washers (5) and one nut (6).
4. Tighten using the Phillips screwdriver for the screws (3, 4) and the adjustable wrench for the nut (6).
5. Repeat the above steps for the other stand handle (2).

Fig. D

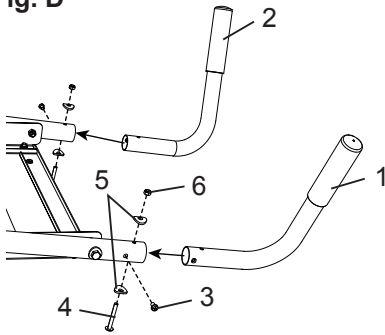

## SETTING UP THE STAND (FIG. E, F)

1. Lift up the stand to its vertical position as shown first in Fig. E.
2. To unfold stand, step on the foot pedal (1) to release the treadle hook (2). Press down on the stand handles to roll the wheel legs backward and lower the stand to lock into its work position, as shown last in Fig. E.

**NOTE:** You should hear a click when locked in place.

Fig. E

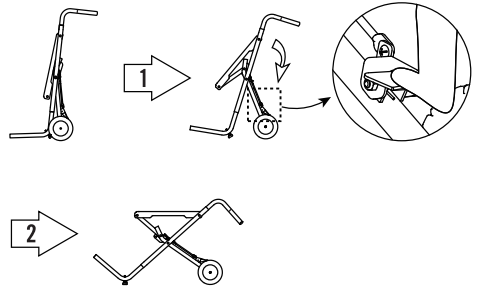
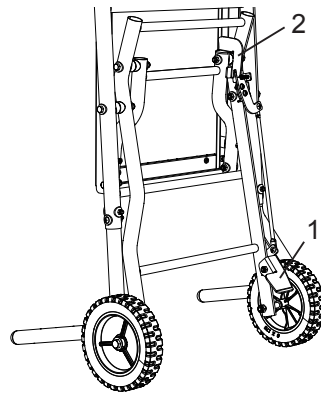

Fig. F



## **⚠ WARNING**

**For your safety, never connect plug to power source receptacle until all assembly and adjustment steps are complete, and you have read and understood the safety instructions.**

## ASSEMBLING TABLE SAW TO STAND (FIG. G)

1. Lift the saw body (1) and place on the stand (2), aligning the four mounting holds (3) on the saw base with the four threaded mounting holes on the top plate of stand.

- Attach the table saw to the stand with four hex head bolts (4) and washers (5).
- Tighten all mounting bolts with an adjustable wrench.  
**NOTE:** Do not overtighten the four bolts as this may cause damage to the base of the saw.

**Fig. G**

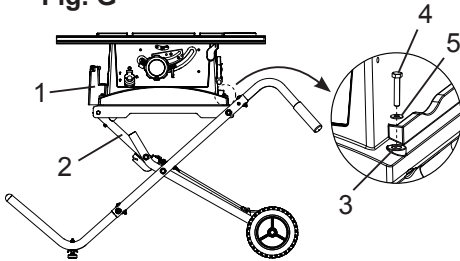

**NOTE:** Before using the saw, verify that the table saw is securely locked in position.

### FOLDING THE STAND FOR TRANSPORT OR STORAGE (FIG. H)

**NOTE:** Before folding the stand, make sure the side extension table is not extended and is locked in place.

- Step on the foot pedal (1), and slowly lift up on the stand handles (2) to roll the wheel legs forward and lower the saw body to lock onto the front of the stand. You should hear a click from the treadle hook locking into place.
- Place one foot on the wheel legs crossbar for leverage to initially tilt stand back onto its wheels into the transport position. Move saw to desired location for operation.
- Store the saw in a dry environment by lowering the stand from the transport position all the way down to rest on the stand handles.

**Fig. H**

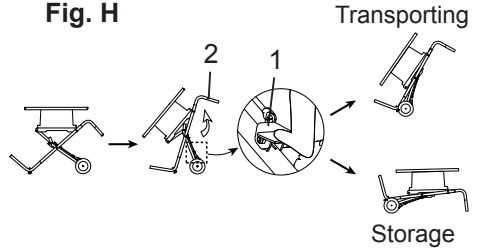

### RIP FENCE AND MITER GAUGE STORAGE (FIG. I)

Storage for the rip fence (1) and miter gauge (2) are located on the left side of the saw housing.

**Fig. I**

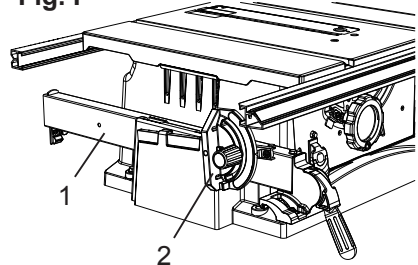

### PUSH STICK AND BLADE WRENCHES STORAGE (FIG. J)

- Attach the metal push-stick storage bracket (1) into the provided slots on the right side of the body shell (3). The bracket will snap into place.
- Insert the blade wrenches into the slot (2) located to the right side of the body shell (3).

**Fig. J**

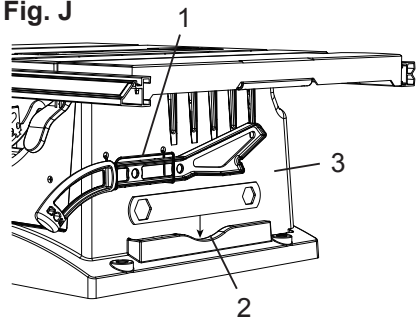

## INSTALLING THE POWER CORD STORAGE CLAMPS (FIG. K)

1. Attach the power cord storage clamp (1) into the hole set on the rear side of the table saw base with screw (2) and nut (3).

**NOTE:** The nut is placed inside the base.

2. Repeat for the other clamp, to be located on the bottom right on saw base.

Fig. K

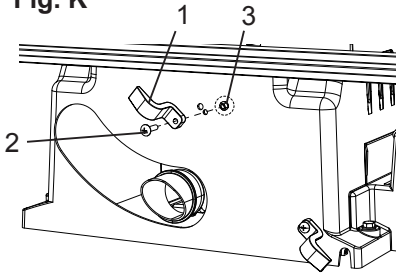

## POWER CORD STORAGE (FIG. L)

Wrap the power cord (1) as shown. Do not wrap the power cord around the dust port (2).

Fig. L

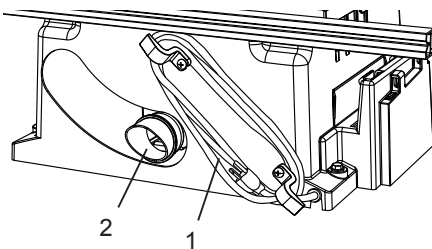

## INSTALLING THE HANDWHEEL HANDLE (FIG. M)

**NOTE:** UP-DOWN is printed on this handwheel.

1. Thread the handwheel handle (1) into the handwheel hole (2), and then tighten with the adjustable wrench.

Fig. M

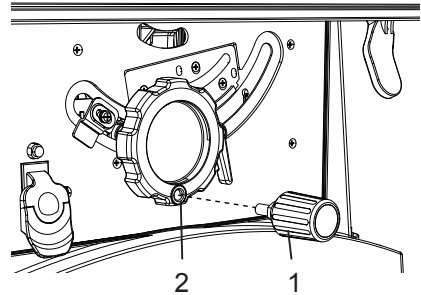

## INSTALLING THE BLADE (FIG. N, O, P)

### ⚠ WARNING

To avoid injury from an accidental start, make sure the switch is in the OFF position and the plug is not connected to the power source outlet.

1. Remove the table insert (1) by inserting your finger into the opening (2) and pulling up. Raise the blade to the maximum height position by turning the blade elevation/tilting handwheel clockwise. (Fig. N)

Fig. N

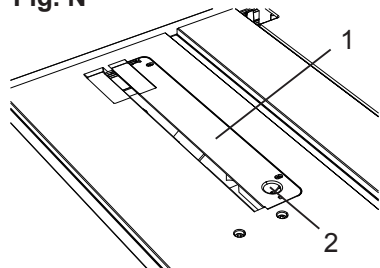

- Remove the arbor nut (3) and outer blade flange (4). (Fig. O)

**Fig. O**

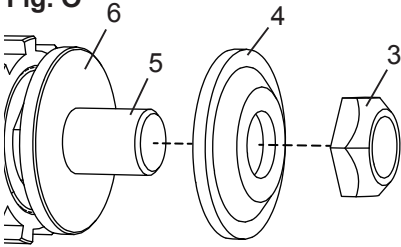

- Place the blade (7) onto the arbor (5) with the blade teeth pointing forward to the front of the saw. (Fig. P)

**NOTE:** Leave the plastic strip around the saw blade at this time. Remove before using the saw for the first time.

- Make sure the blade fits flush against the inner flange (6). (Fig. O)
- Clean the outer blade flange (4) and install it onto the arbor (5) and against the blade (7). (Fig. P)
- Thread the arbor nut (3) onto the arbor, making sure the flat side of the nut is against the blade, then hand-tighten.
- To tighten the arbor nut (3), place the open-end wrench (8) on the flats of the saw arbor to keep the arbor from turning. (Fig. P)

**TIP:** With one hand place open-end wrench down onto arbor. Wear protective glove and rotate blade toward you with the other hand until the wrench finds and drops down onto arbor flats.

- While retaining hold of open-end wrench with one hand, with other hand place the box-end wrench on the arbor nut (3). Push box-end wrench away from you (to rear of saw table) to turn nut clockwise and tighten it on arbor.

- Lower the blade to its lowest position and place table insert (1) into position. (Fig. N)

**Fig. P**

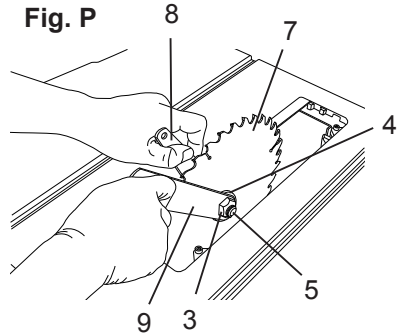

**NOTE:** DO NOT THROW OUT THESE TWO WRENCHES. You will need them for blade removal. (See Section on REMOVING THE BLADE on page 35.)

### **⚠ WARNING**

To avoid possible injury and damage to the workpiece, be sure to **INSTALL THE BLADE WITH THE TEETH POINTING TOWARD THE FRONT OF TABLE** in the direction of the rotation arrow on the blade guard.

### **INSTALLING THE RIVING KNIFE (FIG. Q, R, S)**

### **⚠ WARNING**

- To avoid injury from an accidental start, make sure the switch is in the **OFF** position and the plug is disconnected from the power source outlet.
- Never operate this saw without the riving knife in the correct position.

- Remove the table insert.



2. Raise the blade to the maximum height position by turning the blade elevation/tilting handwheel (1) clockwise. (Fig. Q)
3. Loosen the blade lock handle (2).
4. Turn and move the handwheel (1) to 45° on the bevel scale.
4. Tighten the blade lock handle (2).

**Fig. Q**

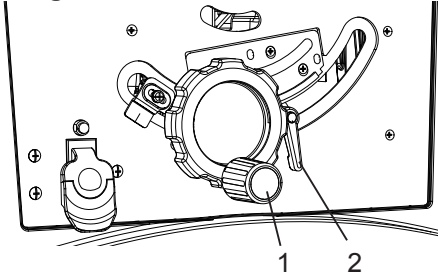

5. Place the riving knife (3) on the mounting bracket (4) located behind the saw blade. The two pins (5) on the bracket should fit into the slot on the riving knife. (Fig. R)
6. Make sure the riving knife (3) is in its highest position.
7. Insert the set plate (6), making sure the two outer holes fit into the two pins on the mounting bracket.
8. Insert the washer (7) into the lock lever (8) and insert into the middle hole of the set plate (6) and tighten.
9. Loosen the blade lock knob (2) and return the blade to 0° and lock.
10. Place the table insert back into position.

**⚠ WARNING**

- To avoid the lock lever interfering with the table insert, after tighten the riving knife, position the lock lever pointing downward before using saw. Failure to maintain a level insert can result in serious injury to the operator.

- The lever can be pulled out to allow it to be turned to a new position downward. (Fig. S)

**Fig. R**

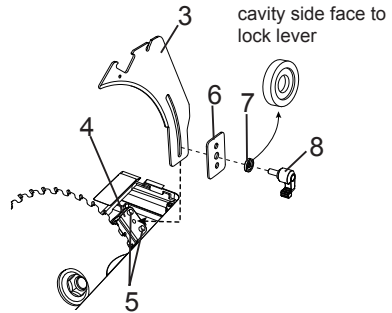

**Fig. S**

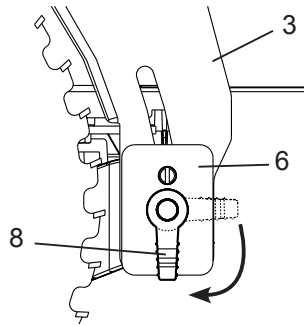

**BLADE GUARD AND ANTI-KICKBACK PAWLS ASSEMBLY (FIG. T, U, V, W)**

**⚠ WARNING**

- To avoid injury from an accidental start, make sure the switch is in the OFF position and the plug is disconnected from the power source outlet.
- When installing the blade guard, cover the blade teeth with a piece of folded cardboard to protect yourself from possible injury.
- Never operate this machine without the blade guard in place for all through sawing operations.

**Installing the blade guard and anti-kickback pawls assembly (Fig. T, U, V, W)**

1. Make sure the blade is elevated to its maximum height and the bevel is set at 0°. Make sure the blade lock knob is tight.
2. Raise the riving knife (1) to its highest position (through cut position). Take the anti-kickback pawls assembly and lift up the locking lever (2) located on top. (Fig. T)
3. Place the front of assembly into slot (3) and push down, making sure the assembly is engaged in the slot (3). Push down on the locking lever (2) to lock. (Fig. T, U)

**NOTE:** Make sure the anti-kickback pawls assembly is locked in position before operating saw.

4. Take the blade guard (4) and press down on the red spring button (5) located on the top of assembly. (Fig. V)
5. Position blade guard over the riving knife (1) and align the slot (6) to the riving knife (1) as shown in Fig. V.
6. Lower the guard assembly (4) onto riving knife (1). Release the red spring button (5) so that two latches (7) engage into two locking hooks (8) completely. (Fig. V, W)
7. Make sure that the assembly is locked in place both in front and back. (Fig. W)

**⚠ WARNING**

**To reduce the risk of serious injury, use saw blade guard and riving knife for every operation for which it can be used including all through sawing.**

**Fig. T**

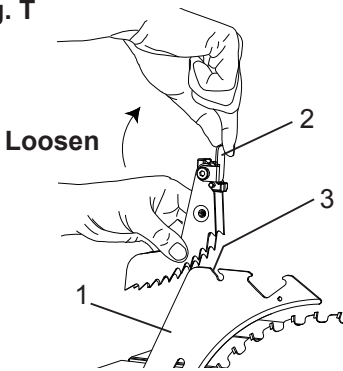

**Fig. U**

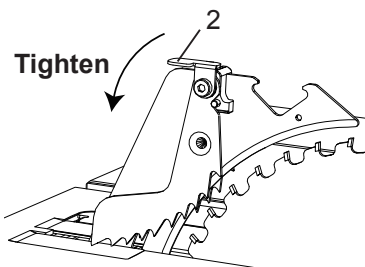

**Fig. V**

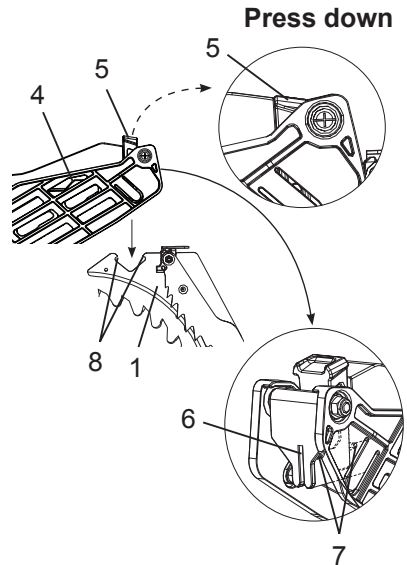

**Fig. W**

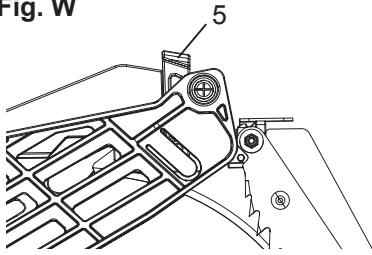

**Removing the blade guard and anti-kickback pawls assembly (Fig. T, W)**

**⚠ WARNING**

To avoid injury from an accidental start, make sure the switch is in the OFF position and the plug is disconnected from the power source outlet.

1. Raise the blade to the maximum height position by turning the blade elevation/tilting handwheel clockwise.
2. Loosen the blade bevel lock knob and turn the handwheel to 90° on the bevel scale.
3. Tighten the blade bevel lock knob.
4. Remove the anti-kickback pawls assembly by lifting the anti-kickback pawls lever (2). (Fig. T)
5. Remove the blade guard assembly by pressing down the red spring button (5) and lifting up the assembly. (Fig. W)

**AVOIDING KICKBACKS (FIG. X)**

To avoid kickback (having the work thrown violently back toward you), keep the blade sharp, keep the rip fence parallel to the saw blade and keep the riving knife, blade guard and anti-kickback pawls in place, aligned and functioning. Do not release the work before passing it completely beyond the saw blade. Do not rip work that is twisted, warped or does not have a straight edge to guide it along the fence. Do not attempt to back out of a cut with the blade running.

**⚠ WARNING**

Improper riving knife alignment can cause “kickback” and serious injury.

**Fig. X**

Anti-kickback Pawls

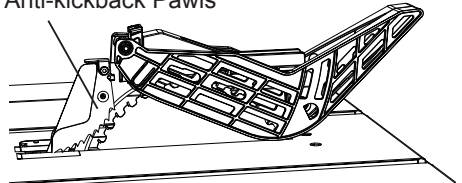

**INSTALLING THE RIP FENCE (FIG. Y)**

1. Lift upward on the rip fence handle (1) so that the holding clamp (2) is fully extended.
2. Place the rip fence on the saw table and engage the holding clamp (2) to the table rear rail. Lower the front end onto the front rail (3).
3. Push down the rip fence handle (1) to lock.

Fig. Y

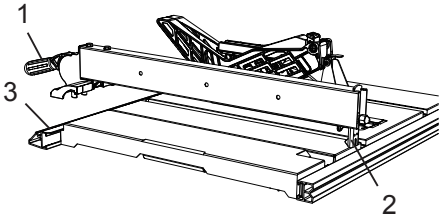

**▲ WARNING**

Never use a rip fence and miter gauge together.

# ADJUSTMENT

## RIP FENCE ADJUSTMENT (FIG. Z)

1. The fence (1) can be repositioned by lifting up the handle (2) and sliding the fence to the desired location. Pushing down the handle locks the fence in position.
2. Position the fence (1) on the right side of the table, and along one edge of the miter gauge grooves.
3. Lock the fence handle (2). The fence should be parallel with the miter gauge groove.
4. If adjustment is needed to make the fence parallel to the groove, do the following:
  - Loosen the two screws (3) and lift up on the handle (2).
  - Hold the fence bracket (4) firmly against the front of the saw table. Move the rip fence until it is parallel with the miter gauge groove.
  - Tighten both screws and push the handle to lock.
5. If fence is loose when the handle is in the locked (downward) position, do the following:
  - Lift the handle (2) upward and turn the adjusting nut (5) clockwise using an adjustable wrench until the rear clamp is snug. Do not turn the adjusting nut more than 1/4 turn at a time.
  - Over-tightening the adjusting nut will cause the fence to come out of alignment.

## WARNING

Failure to properly align the fence can cause “kickback” and serious injury could occur.

Fig. Z

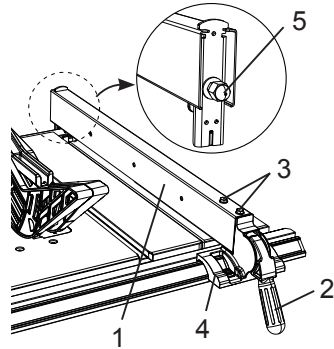

## RIP FENCE INDICATOR ADJUSTMENT (FIG. AA)

1. The rip fence indicator (1) points to the measurement scale (2). The scale shows the distance from the side of the fence to nearest side of the blade.
2. Measure the actual distance with a rule. If there is a difference between the measurement and the indicator, adjust the indicator (1).
3. Loosen the screw (3) and slide the indicator to the correct measurement on the scale (2). Tighten the screw and remeasure with the rule.

Fig. AA

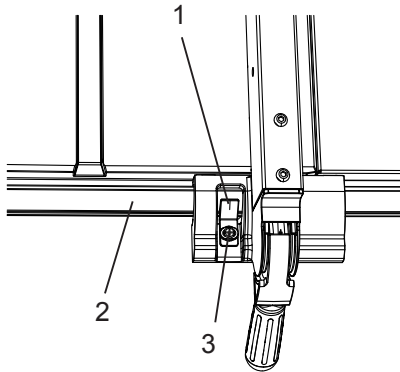

### ADJUSTING MITER GAUGE (FIG. BB)

1. Loosen the lock handle (1) to allow the miter body (2) to rotate freely. Position the miter body (2) at  $90^\circ$  so the positive detent secures its position. Tighten the lock handle to hold the miter body in position.
2. If the pointer (3) requires adjustment, loosen the screw (4) with a screwdriver. Adjust the pointer to  $90^\circ$  on the scale, then firmly tighten the adjustment screw.
3. To change angles on the miter gauge, loosen the lock handle (1) and rotate the miter body (2) to the desired angle as indicated by the scale. Secure in position by tightening the lock handle (1).

Fig. BB

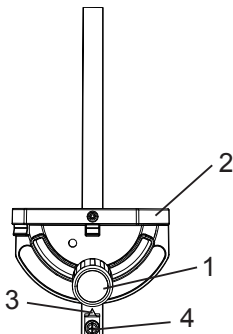

### ADJUSTING THE TABLE INSERT (FIG. CC)

#### **⚠ WARNING**

To avoid serious injury, the table insert (1) must be level with the table. If the table insert is not flush with the table, adjust the two bolts (2) with a 4 mm hex wrench until it is parallel with the table.

**NOTE:** To raise the insert, turn the hex screws counterclockwise, to lower the insert, turn the hex screws clockwise. Do not remove the insert, adjustments need to be made with the insert in place to get the proper level.

Fig. CC

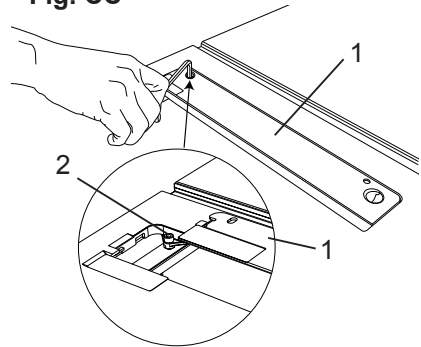

### ADJUSTING THE $90^\circ$ AND $45^\circ$ POSITIVE STOPS (FIG. DD, EE)

Your saw has positive stops that will quickly position the saw blade at  $90^\circ$  and  $45^\circ$  to the table. Make adjustments only if necessary.

#### **$90^\circ$ Stop**

1. Disconnect the saw from the power source.
2. Raise the blade to the maximum elevation.

- Loosen the blade lock knob and move the blade to the maximum vertical position and tighten the blade lock knob.
- Place a combination square on the table and against the blade (1) to determine if the blade is 90° to the table. (Fig. DD)
- If the blade is not 90° to the table, loosen or tighten (depending on whether you are increasing or decreasing the degrees) the hex bolt (3) with a 5 mm hex wrench until you achieve 90°. (Fig. EE)
- Loosen the blade lock knob and reset the blade at the maximum vertical position, then tighten the blade lock knob.
- Check again to see if the blade is 90° to the table. If not, repeat step 3.
- Lastly, check the bevel angle scale. If the pointer does not read 90°, loosen the screw holding the pointer and move the pointer so it is accurate at 0° and retighten the pointer screw.

### 45° Stop

- Disconnect the saw from the power source.
- Raise the blade to the maximum elevation.
- Loosen the blade lock knob and move the blade to the maximum bevel position and tighten the blade lock knob.
- Place a combination square on the table and against the blade (2) to determine if the blade is 45° to the table. (Fig. DD)
- If the blade is not 45° to the table, loosen or tighten (depending on whether you are increasing or decreasing the degrees) the hex bolt (4) with a 5 mm hex wrench until you achieve 45°. (Fig. EE)
- Loosen the blade lock knob and reset the blade at the maximum bevel position (45°), then tighten the blade lock knob.
- Check again to see if the blade is 45° to the table. If not, repeat step 5.

**Fig. DD**

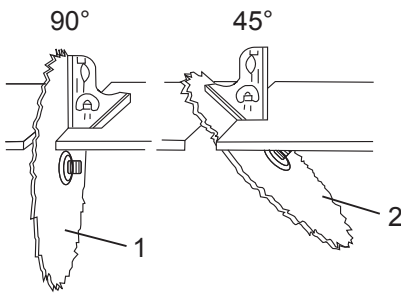

**Fig. EE**

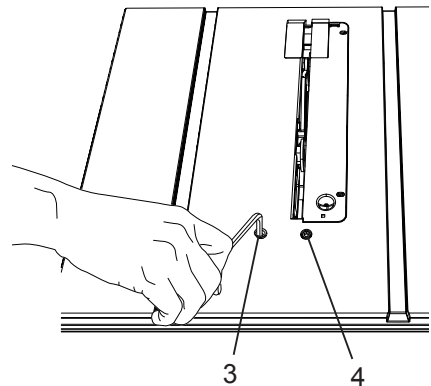

### BLADE TILT POINTER (FIG. FF)

1. When the blade is positioned at 90°, adjust the blade tilt pointer (1) to read 0° on the scale.
2. Loosen the holding screw (2), position the pointer over 0° and tighten the screw.

**NOTE:** Make a trial cut on scrap wood before making critical cuts. Measure for exactness.

Fig. FF

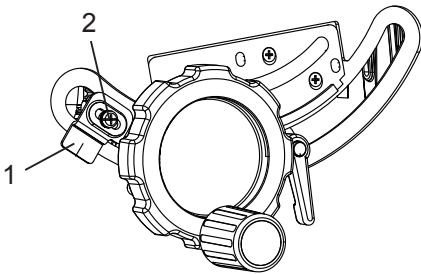

### BLADE PARALLEL TO THE MITER GAUGE GROOVE (FIG. GG)

#### **⚠ WARNING**

This adjustment was made at the factory, but it must be rechecked and adjusted if necessary.

#### **⚠ WARNING**

To prevent personal injury:

- Always disconnect plug from the power source when making any adjustments.
- Inaccurate adjustment can result in kickback and serious personal injury. This adjustment must be correct or accurate cuts cannot be made.

1. Remove the safety switch key and unplug the saw.
2. Remove the blade guard for this procedure but reinstall and realign after adjustment.
3. Raise the blade to the highest position and set at the 0° angle (90° straight up).
4. Select and mark, with a felt tip marker, a blade tooth having a “right set” and rotate the blade so the marked tooth is 1/2 in. above the table.
5. Place the combination square base (1) into the right side miter gauge groove (2).
6. Adjust the rule so it touches the front marked tooth and lock ruler so it holds its position in the square assembly.
7. Rotate the blade bringing the marked tooth to the rear and about 1/2 in. above the blade.
8. Carefully slide the combination square to the rear until the ruler touches the marked tooth.
9. If the ruler touches the marked tooth at the front and rear position, no adjustment is needed at this time. If not or the base of the rule is no longer parallel with the edge of the miter gauge groove, see adjustment procedure described in next section.

Fig. GG

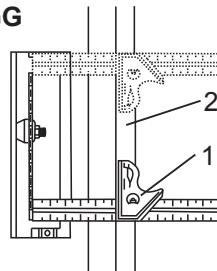



## ADDITIONAL BLADE ADJUSTMENTS (FIG. HH)

**NOTE:** The adjusting mechanism is located above the the blade elevation/tilting handwheel under the table top. If the front and rear measurements are not the same:

### If the blade is partial to right side:

1. Turn the left adjustment screw (1) counterclockwise and adjust the right side adjustment screw (2) clockwise.
2. Remeasure, as described in steps 4 to 9 in the prior section.
3. When alignment is achieved, turn the left adjustment screw (1) until it touches the pivot rod (3).

### If the blade is partial to left side:

1. Turn the right adjustment screw (2) counterclockwise and adjust the left side adjustment screw (1) clockwise.
2. Remeasure, as described in steps 4 to 9 in the prior section.
3. When alignment is achieved, turn the right adjustment screw (2) until it touches the pivot rod (3).

Fig. HH

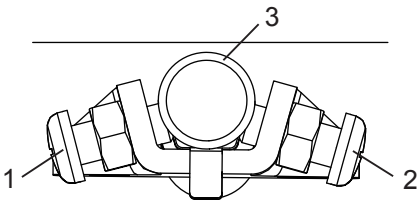

## ALIGNING THE RIVING KNIFE (FIG. II)

### **⚠ WARNING**

- To avoid injury from an accidental start, make sure the switch is in the OFF position and the plug is disconnected from the power source outlet.
  - Never operate this tool without the riving knife in the correct position.
  - Never operate this tool without the blade guard in place for all through sawing operations.
  - This adjustment was made at the factory, but it should be rechecked and adjusted if necessary.
1. Remove the table insert and raise the blade to the maximum height by turning the blade elevation/tilting handwheel clockwise.
  2. Remove the blade guard and anti-kickback pawls assembly.
  3. Loosen the blade lock knob. Turn and move the blade elevation/tilting handwheel to 0° on the bevel scale, and then tighten the blade lock knob.
  4. To see if the blade (1) and riving knife (2) are correctly aligned, lay a combination square (3) along the side of the blade and against the riving knife (making sure the square is between the teeth of the blade).
  5. Tilt the blade to the 45° position and check the alignment again.
  6. If the blade and riving knife are not correctly aligned:

- a. Remove the lock lever (4), washer (5), set plate (6) and riving knife (2) from the mounting bracket (7).
  - b. Insert the washer (8) between the riving knife and bracket (7).
  - c. Replace the riving knife (2), set plate (6), washer (5) and lock lever (4). Then, retighten the lock lever (4)
7. Check the riving knife and blade alignment again at both 0° and 45°.
  8. Add or remove the washers until the alignment is correct.
  9. Replace the table insert, blade guard and anti-kickback pawls assembly.

**Fig. II**

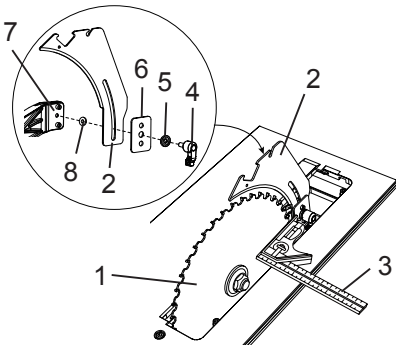

**NOTE:**

- This table saw is provided with a 10 in. diameter blade with a body thickness of 0.07 in. thick with a kerf of 0.10 in. The riving knife is 0.09 in. thick. The blade diameter and the blade body and kerf dimensions must be properly matched with the riving knife thickness.
- The maximum radial distance between the riving knife and the toothed rim of the saw blade is 0.12 in ~ 0.31 in.

- The tip of the riving knife shall not be lower than 0.04 in. ~ 0.2 in. from the tooth peak.
- The riving knife is thinner than the width of the kerf by approximately 1/64 in. on each side.
- The blade body must be thinner than the thickness of the riving knife but the blade kerf must be thicker than the riving knife.

**ADJUSTING CAM LOCKING LEVER (FIG. JJ)**

If the extension table moves when it is open and locked in place, the cam locking lever (1) may be loose and require adjustment. Therefore, adjustment to the cam locking lever is necessary. To adjust the cam locking lever tension, turn the bar (2) with an adjustable wrench until it is tightened correctly, but do not over tighten.

**Fig. JJ**

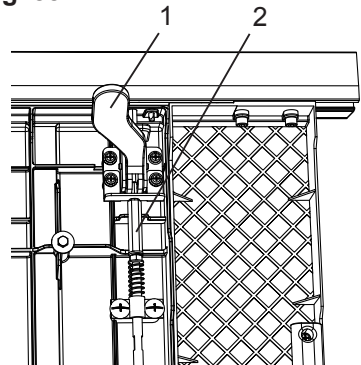

Under Table View

## REMOVING THE BLADE (FIG. KK, LL)

### **▲ WARNING**

To avoid injury from an accidental start, make sure the switch is in the OFF position and the plug is not connected to the power source outlet.

1. Remove the blade guard and anti-kickback pawls assembly. See **Removing blade guard and anti-kickback pawls assembly** instructions section.
2. Stand before the front side of saw. Remove the table insert (1) by inserting your finger into the opening (2) and pulling up. Raise the blade to the maximum height position by turning the blade elevation/tilting handwheel clockwise. (Fig. KK)
3. To loosen the arbor nut (3), place the open-end wrench (8) on the flats of the saw arbor to keep the arbor from turning. (Fig. LL)  
**TIP:** With one hand place open end of wrench down onto arbor. Wear protective glove on other hand and rotate blade toward you until wrench finds and drops down onto arbor flats.
4. While retaining hold of open end wrench with one hand, with other hand place the box-end wrench on the arbor nut (3). Pull box-end wrench toward you to turn nut counterclockwise and loosen it from arbor.

5. Remove the arbor nut (3), outer blade flange (4) and blade (7). Clean but do not remove the inner blade flange before reassembling the blade.
6. Replace the table insert, blade guard and anti-kickback pawls assembly.

**Fig. KK**

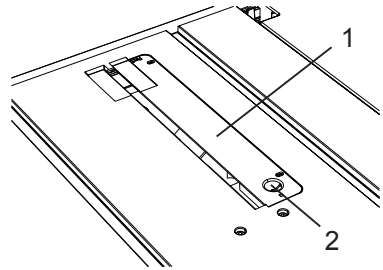

**Fig. LL**

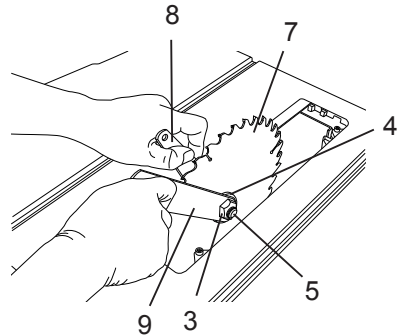

# OPERATION

## BASIC SAW OPERATIONS

### RAISING THE BLADE (FIG. MM)

To raise or lower the blade, turn the blade elevation/tilting handwheel (1) to the desired blade height.

Fig. MM

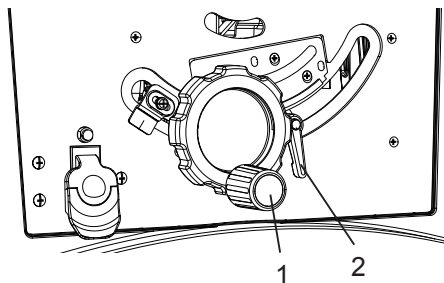

### TILTING THE BLADE (FIG. MM)

Loosen the blade lock handle (2), move the handwheel (1) to the desired angle, then tighten the blade lock handle (2).

### ON/OFF SWITCH (FIG. NN)

The ON/OFF switch has a safety switch key (1). With the key removed from the switch, unauthorized and hazardous use by children and others is minimized.

1. To turn the saw ON, insert the safety switch key (1) into the slot in the switch (2). Move the switch upward to the ON position.
2. To turn the saw OFF, press the switch downward.
3. To lock the switch in the OFF position, grasp the yellow part of the safety switch key (1), and pull it out.
4. With the safety switch key removed, the switch will not operate.

5. If the safety switch key is removed while the saw is running, it can be turned OFF but cannot be restarted without inserting the safety switch key (1).

### **⚠ WARNING**

**ALWAYS lock the switch “OFF” when the saw is not in use. Remove the safety switch key and keep it in a safe place. In the event of a power failure, blown fuse, or tripped circuit breaker, turn the switch “OFF” and remove the safety switch key, preventing an accidental startup when power comes on.**

Fig. NN

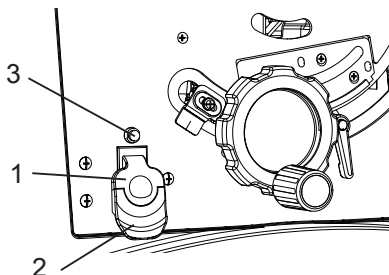

### OVERLOAD PROTECTION (FIG. NN)

This saw has an overload reset button (3) that resets the motor after it shuts off due to overloading or low voltage. If the motor stops during operation, turn the ON/OFF switch to the OFF position. Wait about five minutes for the motor to cool, then push the reset button (3) and turn the switch to the ON position.

## **⚠ WARNING**

To avoid injury, the ON/OFF switch should be in the OFF position and the plug removed from the power source while the cool down takes place, to prevent accidental starting when the reset button is pushed. Overheating may be caused by misaligned parts or a dull blade or undersized extending cord. Inspect your saw for proper setup before using it again.

### USING THE DUST PORT (FIG. OO)

## **⚠ WARNING**

To prevent fire hazard, clean and remove sawdust from under the saw frequently.

To prevent sawdust buildup inside the saw housing, attach a vacuum hose (1) to the dust port (2) at the rear of the table saw. DO NOT operate the saw with the hose in place unless the vacuum is turned on.

Fig. OO

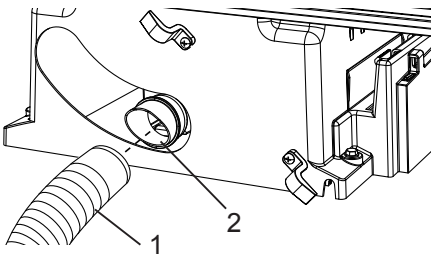

### USING THE EXTENSION TABLE (FIG. PP)

1. Release the extension cam locking lever (1) in the front and rear table positions.
2. Slide the extension table (2) out until the correct measurement is displayed on the scale (3). The user sights the scale off the edge of the table.
3. Tighten the extension cam locking lever (1).

Fig. PP

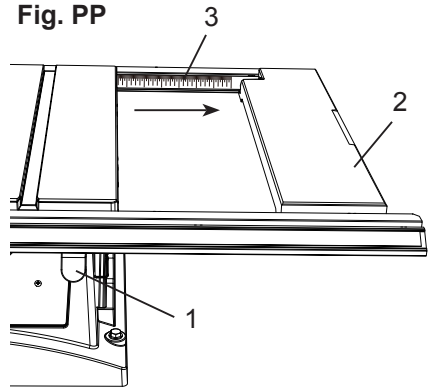

### CUTTING OPERATIONS

There are two basic types of cuts: ripping and crosscutting. Ripping is cutting along the length and the grain of the workpiece. Crosscutting is cutting either across the width or across the grain of the workpiece. (It is not safe to rip or crosscut by freehand). Ripping requires the use of the rip fence, and crosscutting requires the miter gauge.

## **⚠ WARNING**

**NEVER USE A RIP FENCE AND MITER GAUGE TOGETHER.**

## **⚠ WARNING**

Before using the saw each time, check the following:

1. The blade is tightened to the arbor.
2. The blade lock handle is tightened.
3. If ripping, make sure the fence is locked into position and is parallel to the miter gauge groove.
4. The blade guard is in place and working properly.
5. Safety glasses are worn.
6. Make sure that the table insert is level with the saw table.

Failure to adhere to these common safety rules, and those printed in the front of this manual, can greatly increase the likelihood of injury.

### **RIPPING (FIG. QQ, RR)**

## **⚠ WARNING**

To prevent serious injury:

- Never use a miter gauge when ripping.
- Never use more than one rip fence during a single cut.
- Do not allow familiarity or frequent use of your table saw to cause careless mistakes. Remember that even a careless fraction of a second is enough to cause a severe injury.
- Keep both hands away from the blade and clear from the path of the blade.
- The workpiece must have a straight edge against the fence and must not be warped, twisted, or bowed when ripping.

1. Remove the miter gauge and store it in the “storage” compartment in the base of the saw.
2. Secure the rip fence to the table.
3. Raise the blade so it is about 1/8 in. higher than the top of the workpiece.
4. Place the workpiece flat on the table and against the fence. Keep the workpiece away from the blade.
5. Turn the saw ON and wait for the blade to come to full speed.
6. Slowly feed the workpiece into the blade by pushing forward only on the workpiece section (1) that will pass between the blade and the fence. (Fig. QQ)
7. Keep your thumbs off the table top. When both of your thumbs touch the front edge of the table (2), finish the cut with a push stick (3). To make an additional push stick, use the pattern on page 52. (Fig. RR)

## **⚠ WARNING**

**AVOID KICKBACK** by pushing forward on the section of the workpiece that passes between the blade and the fence. Never perform any freehand operations.

**Fig. QQ**

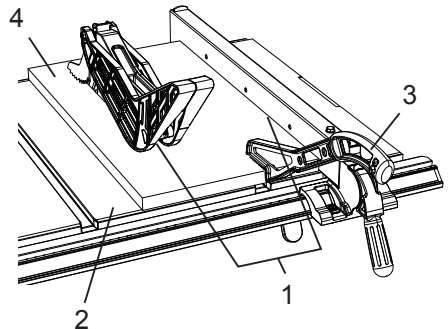

## **⚠ WARNING**

When width or rip is narrower than 2 in., the push stick cannot be used because the blade guard will interfere. Use an auxiliary fence (5) (see page 40) to see how to make an auxiliary fence and push block (6) (see page 41 to how to make a push block) as shown in Fig. RR.

Fig. RR

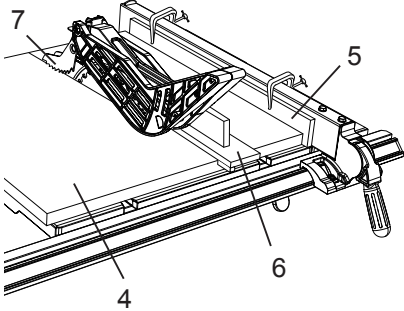

- 8. Continue pushing the workpiece (4) with the push stick (3) or push block (6 - Fig. RR) until it passes through the blade guard and clears the rear of the table. (Fig. QQ)
- 9. Never pull the piece back when the blade is turning. Turn the switch Off. When the blade completely stops, you can then remove the workpiece.

## **⚠ WARNING**

Never attempt to pull the workpiece backwards during a cutting operation. This will cause kickback and serious injury to the user can occur. When the blade completely stops, raise the anti-kickback pawls assembly (7) on each side of the riving knife and slide the workpiece out. (Fig. RR)

## **BEVEL RIPPING**

This cut is the same as ripping except the blade bevel angle is set to an angle other than 0°.

## **RIPPING SMALL PIECES**

To avoid injury from blade contact, never make cuts narrower than 3/4 in. wide.

- 1. It is unsafe to rip small pieces. Instead, rip a larger piece to obtain the size of the desired piece.
- 2. When a small width is to be ripped, and your hand cannot be safely put between the blade and the rip fence, use push stick or push block to pass the workpiece completely through and past the blade.

## **HELPFUL DEVICES**

In order to make some cuts, it is necessary to use devices like a push block, featherboard or auxiliary fence, which you can make yourself. Here are some templates for your reference.

## **FEATHERBOARD (FIG. SS, TT)**

A featherboard is a device used to help control the workpiece by guiding it securely against the table or fence. Featherboards are especially useful when ripping small workpieces and for completing non-through cuts. The end is angled with a number of short kerfs to give a friction hold on the workpiece and locked in place on the table with C-clamps. Test that it can resist kickback.

## **⚠ WARNING**

Place the featherboard against the uncut portion of the workpiece to avoid kickback that could cause serious personal injury.

### **MAKE A FEATHERBOARD (FIG. SS)**

Select a solid piece of lumber approximately 3/4 in. thick, 4 in. wide and 18 in. long. To make a featherboard, cut one end of the lumber at 60 degrees, then cut 8 in. long slots 1/4 in. apart on the angled end as shown in Fig. RR.

**Fig. SS**

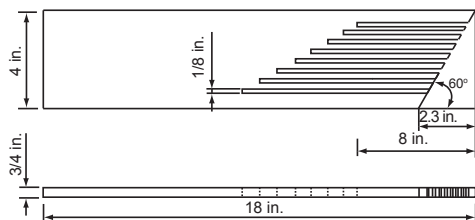

### **USE A FEATHERBOARD (FIG. TT)**

## **⚠ WARNING**

- Never feed wood with your hands when making any non-through cuts such as rabbets or dadoes. To avoid personal injury, always use push sticks (1), push blocks and featherboards.
- Do not locate the featherboard to the rear of the blade. If positioned improperly, kickback can result from the featherboard pinching the workpiece and binding the blade in the saw kerf. Featherboards are not used during non-through-sawing operations when using the miter

gauge. Failure to heed these warnings can result in serious personal injury.

1. Lower the saw blade.
2. Position the rip fence (2) to the desired position and lock the rip fence.
3. Place the workpiece (3) against the fence and over the saw blade area.
4. Adjust the featherboard (4) to resist the workpiece forward of the blade.
5. Attached the C-clamps (5) to secure the featherboard to the edge of the table.

**Fig. TT**

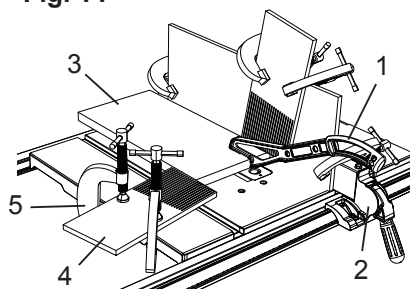

### **AUXILIARY FENCE (FIG. UU)**

#### **Making the base:**

- Start with a piece of 3/8 in. plywood at least 5-1/2 in. wide or wider and 21 in. long or longer.
- Cut the piece to shape and size shown.

#### **Making the side:**

- Start with a piece of 3/4 in. hardwood at least 1-3/4 in. wide or wider and 21 in. long or longer.
- Cut the piece to shape and size shown.



### Putting it together:

- Fasten the pieces together with glue and woodscrews.

### **⚠ WARNING**

Make sure the screw heads do not stick out from the bottom of the base; they must be flush or recessed. The bottom must be flat and smooth enough to rest on the saw table without rocking.

Fig. UU

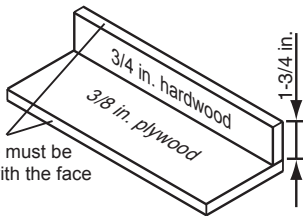
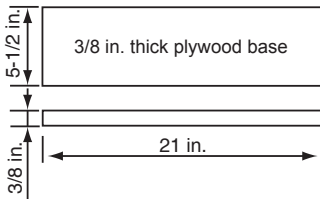

### PUSH BLOCK

Use for ripping operation when the workpiece is too narrow to use a push stick. Always use a push block for rip widths less than 2 inches.

### MAKE A PUSH BLOCK (FIG. VV)

#### Making the base:

- Start with 3/8 in. plywood at least 5-1/2 in. wide or wider and 12 in. long or longer.
- Cut the piece to shape and size as shown.

### Making the handle:

- Start with 3/4 in. hardwood at least 5 in. wide or wider and 7 in. long or longer.
- Cut the piece to shape and size as shown.

### Making the bracket:

- Start with 3/8 in. wood at least 3/8 in. wide or wider and 2-1/2 in. long or longer.
- Cut the piece to shape and size as shown.

### Putting it together:

- Fasten the base and handle together with glue and woodscrews.

### **⚠ WARNING**

Make sure the screw heads do not stick out from the bottom of the base, they must be flush or recessed.

- Fasten the base and bracket together with glue.

### **⚠ WARNING**

To avoid injury, do not use the screws to fasten the base and bracket.

Fig. VV

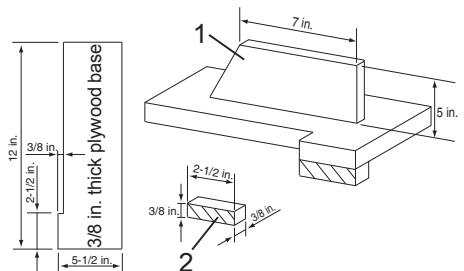

## CROSSCUTTING (FIG. WW)

### **▲ WARNING**

To prevent serious injury:

- Do not allow familiarity or frequent use of your table saw to cause careless mistakes. Remember that even a careless fraction of a second is enough to cause a severe injury.
- Keep both hands away from the blade and the path of the blade.
- Never attempt to pull the workpiece backwards during a cutting operation. This will cause kickback and serious injury to the user can occur.

1. Remove the rip fence and place the miter gauge in the miter gauge groove on the table.
2. Adjust the blade height so that it is 1/8 in. higher than the top of the workpiece.
3. Hold the workpiece firmly against the miter gauge with the blade path in line with the desired cut location. Move the workpiece to a 1 in. distance from the blade.
4. Start the saw and wait for the blade to come up to full speed. Never stand directly in line of the saw blade path, always stand to the side of the blade that you are cutting on.
5. Keep the workpiece (1) against the face of the miter gauge (2) and flat against the table. Then slowly push the workpiece through the blade.

6. Do not try to pull the workpiece back with the blade turning. Turn the switch OFF, and carefully slide the workpiece out when the blade has completely stopped.

### **▲ WARNING**

Always position the larger surface of the workpiece on the table when crosscutting and/or bevel crosscutting to avoid instability.

Fig. WW

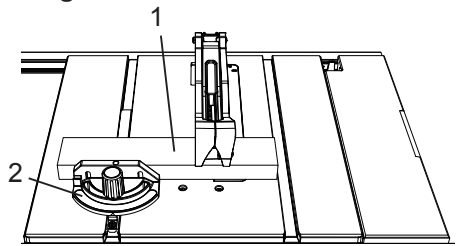

## USING THE WOOD FACING ON THE MITER GAUGE (FIG. XX)

Slots are provided in the miter gauge for attaching an auxiliary facing (1) to make it easier to cut very long or short pieces. Select a suitable piece of smooth wood, drill two holes through it and attach it to the miter gauge with screws. Make sure the facing does not interfere with the proper operation of the saw blade guard. When cutting long workpieces, you can make a simple outfeed support by clamping a piece of plywood to a sawhorse.

### **▲ WARNING**

The height of the outfeed support must be level with the table on saw. It cannot be higher or lower in height.

Fig. XX

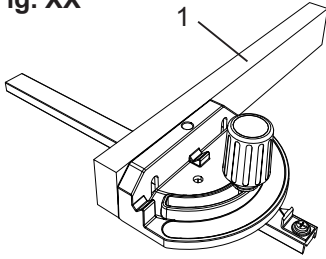

**BEVEL CROSSCUTTING (FIG. YY)**  
 0°~45° blade bevel & 90° miter angle

This cutting operation is the same as crosscutting except the blade is at a bevel angle other than 0°.

**⚠ WARNING**

Always work to the right side of the blade during this type of cut. The miter gauge must be in the right side groove because the bevel angle may cause the blade guard to interfere with the cut if used on the left side groove.

1. Lower the blade to the down position.
2. Adjust the blade (1) to the desired angle, and tighten the blade lock handle.
3. Tighten the miter gauge lock handle (2) at 90°.
4. Hold workpiece (3) firmly against the face of the miter gauge throughout the cutting operation.

Fig. YY

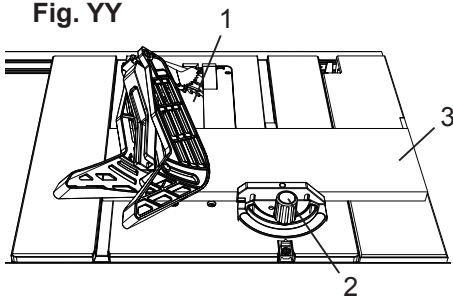

**COMPOUND MITER CROSSCUTTING (FIG. ZZ)**

0°~45° blade bevel & 0°~45° miter angle

This sawing operation combines a miter angle with a bevel angle.

**⚠ WARNING**

Always work to the right side of the blade during this type of cut. The miter gauge must be in the right side groove because the bevel angle may cause the blade guard to interfere with the cut if used on the left side groove.

1. Set the miter gauge (1) to the desired angle.
2. Place the miter gauge in the right side groove of the table.
3. Set the blade (2) bevel to the desired bevel angle.
4. Hold workpiece (3) firmly against the face of the miter gauge throughout the cutting operation.

Fig. ZZ

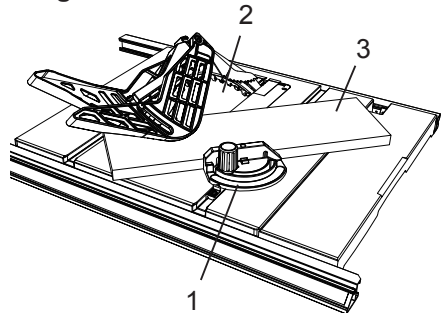

## MITERING (FIG. aa)

### 0°~45° miter angle

This sawing operation is the same as crosscutting except the miter gauge is locked at an angle other than 90°.

1. Set the blade (1) to 0° bevel angle.
2. Set the miter gauge (2) at the desired miter angle and lock in position by tightening the miter gauge lock handle.
3. Hold the workpiece (3) firmly against the face of the miter gauge throughout the cutting operation.

Fig. aa

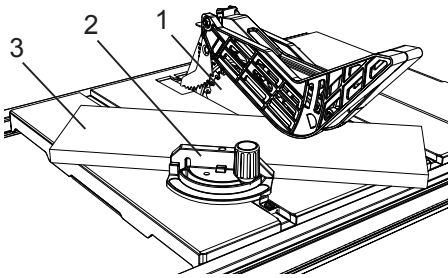

## USING THE WOOD FACING ON THE RIP FENCE (FIG. bb)

When performing some special cutting operations, you can add a wood facing to either side of the rip fence (1).

1. Use a smooth straight 3/4 in. thick wood board (2) that is as long as the rip fence.
2. Attach the wood facing to the fence with wood screws (3) (not included) through the holes in the fence. A wood fence should be used when ripping material such as thin paneling to prevent the material from catching between the bottom of the fence and the table.

Fig. bb

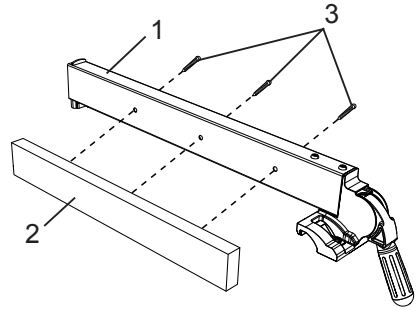

## NON-THROUGH CUT (FIG. cc)

A non-through cut is used to cut grooves and rabbets in the workpiece without exposing the blade.

### ⚠ WARNING

- Only this type cut is made without installing the blade guard assembly and anti-kickback pawls assembly.
  - To avoid injury from an accidental start, make sure the switch is in the OFF position and the plug is disconnected from the power source outlet.
  - To avoid the risk of personal injury. Always use push block, auxiliary fence and featherboard when making non-through cut.
1. Before starting the table saw, lower the blade and riving knife assembly to the down position.
  2. Remove the blade guard assembly and anti-kickback pawls assembly for non-through cut.
  3. Use the featherboard (1) with C-clamps (3) to fasten the workpiece securely.

4. Mount the auxiliary fence (4) with C-clamps.
5. Use the push block (2) to move the workpiece.

**NOTE:** Mount the featherboard to table as shown, so the leading edges of featherboard will help workpiece complete cutting.

**Fig. cc**

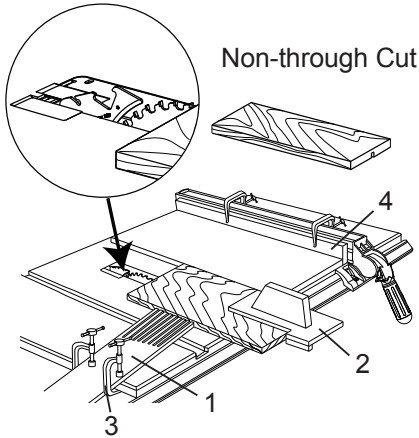

### DADO CUTS (FIG. dd, ee)

#### **⚠ WARNING**

- Only Stackable dado blades can be used on this saw.
- DO NOT use Adjustable or Wobble type dadoes.
- The maximum dado cut width is 1/2 in.
- The maximum dado blade diameter is 6 in.

**NOTE:** An dado insert plate (part number 2YTV not included) is required for this procedure.

1. Remove the table insert, saw blade, anti-kickback pawls assembly, blade guard assembly and riving knife assembly for dado cuts ONLY. Reinstall and realign blade guard for all through-sawing operations. Install a dado not exceeding 6 in. in diameter and 1/2 in. in width.
2. Install the dado table insert making sure that the rear of the insert is flush with the table. If the dado insert is not flush with the table, adjust the two bolts on the insert with a 4 mm hex wrench until it is parallel with the table.
3. Instruction for operating the dado is packed with the separately purchased dado set (not included with unit).
4. The arbor (1) on this saw restricts the maximum width of the cut to 1/2 in.
5. It is not necessary to install the outside flange (2) before threading on the arbor nut (3) for the maximum 1/2 in. dado cuts. Make sure that the arbor nut (3) is tight, and that at least one thread of the arbor sticks out past the nut.
6. Use only the correct number of round outside blades and inside chippers as shown in the dado set's instruction manual. Blade or chippers must not exceed 1/2 in. total in width.
7. Check the saw to ensure that the dado will not strike the housing, insert, or motor when in operation.

**Fig. dd**

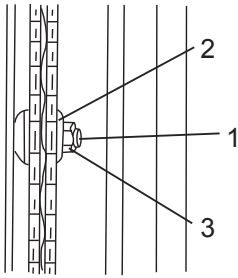

**⚠ WARNING**

**For your own safety, always replace the blade, blade guard assembly, anti-kickback pawls assembly, riving knife assembly and table insert when you finish the dado operation.**

**Fig. ee**

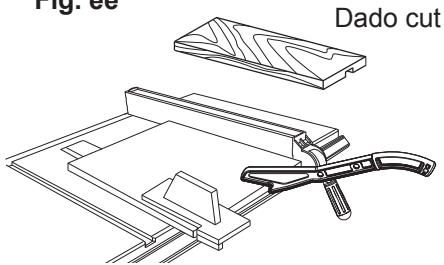

# MAINTENANCE

## MAINTAINING YOUR TABLE SAW

### GENERAL MAINTENANCE

#### **▲ WARNING**

For your own safety, turn the switch OFF and remove the switch key. Remove the plug from the power source outlet before maintaining or lubricating your saw.

1. Clean out all sawdust that has accumulated inside the saw cabinet and the motor.
2. Polish the saw table with an automotive wax to keep it clean and to make it easier to slide the workpiece.
3. Clean cutting blades with pitch and gum remover.
4. A worn, cut, or damaged power cord should be replaced immediately.

#### **▲ WARNING**

All electrical or mechanical repairs should be attempted only by a trained repair technician. Contact customer service for assistance. Use only identical replacement parts. Any other parts may create a hazard.

5. Use liquid dishwashing detergent and water to clean all plastic parts.  
**NOTE:** Certain cleaning chemicals can damage plastic parts.
6. Avoid use of cleaning chemicals or solvents, ammonia and household detergents containing ammonia.

### BLADE RAISING AND TILTING MECHANISM (FIG. ff, gg)

After every five hours of operation, the blade raising mechanism and tilting mechanism should be checked for looseness, binding, or any other abnormalities.

1. With the saw disconnected from the power source, turn the saw upside down and pull up and push down on the motor unit.
2. Observe any movement of the motor mounting mechanism.
3. Loosen or tighten the four hex screws (1) by hex wrench for smooth operation. Adjust only 1/8 turn at a time. (Fig. ff)

**NOTE:** Do not adjust the screw more than 1/2 turn in total as this may damage the mechanism.

Fig. ff

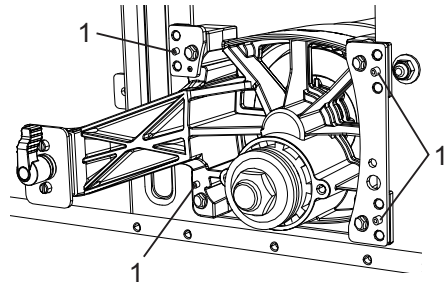

4. Place a small amount of dry lubricant on the bevel gear (2). The worm gear (3) must be kept clean and free of sawdust, gum, pitch, and other contaminants for smooth operations. (Fig. gg)

**Fig. gg**

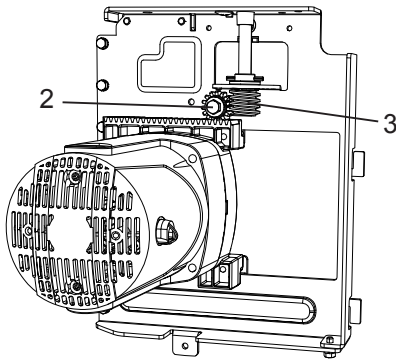

**NOTE:** If excessive looseness is observed in any part of the blade raising mechanism or tilting mechanism, take the complete unit to a Service Center.

### LUBRICATION

All motor bearings are permanently lubricated at the factory and require no additional lubrication. On all mechanical parts of your table saw where a pivot or threaded rod are present, lubricate using graphite or silicone. These dry lubricants will not hold sawdust as would oil or grease.

### REPLACING THE CARBON BRUSHES (FIG. hh, ii)

#### **▲ WARNING**

Always disconnect the plug from the power source before inspecting the brushes.

The carbon brushes included with the unit will last approximately 50 hours of running time, or 10,000 ON/OFF cycles. Replace both carbon brushes when either has less than 1/4 in. length of carbon remaining, or if the spring or wire is damaged or burned.

1. Remove the blade guard, blade, rip fence, miter gauge and stand assembly from the table saw.
2. Lower the blade height to its minimum setting. This will make the brush locations easier to access.
3. Place cardboard or an old blanket on the floor to protect the saw table surface.
4. Place the saw upside down on the protective material.
5. Tilt the blade elevation/tilting handwheel (1) to the 45° position. (Fig. hh)
6. Remove the black plastic cap (2) from the side of the motor (3).

**Fig. hh**

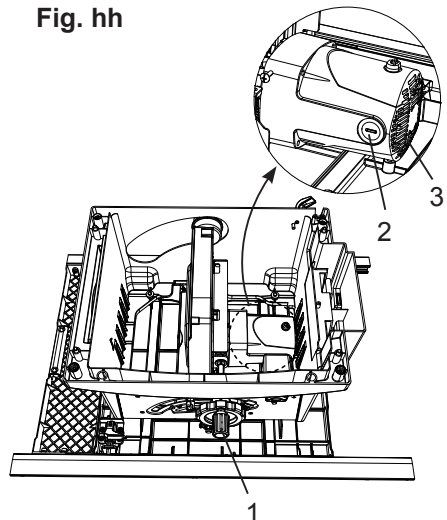



7. Carefully remove the spring-loaded cap, and then pull out the brush (4) and replace. (Fig. ii)
8. Repeat step 6 and 7 for the other side of motor.
9. Place the new brush into the opening of motor, making sure the ears on the metal end of the assembly go in the same hole the carbon part fits into. Do not overtighten the plastic cap.
10. Carefully set the saw in a upright position on a clean level surface.
11. Replace the blade guard, blade, rip fence, miter gauge and stand assembly to the table saw.

**NOTE:** To reinstall the same brushes, first make sure the brushes go back in the same sides they came out. This will avoid a break-in period that reduces motor performance and increases wear.

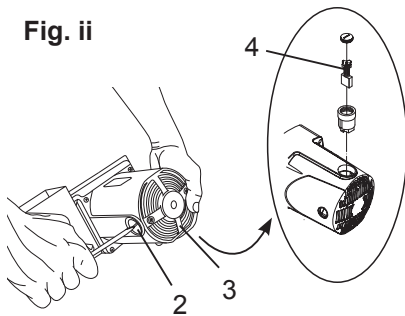

# TROUBLESHOOTING GUIDE

## WARNING

To avoid injury from accidental starting, always turn switch OFF and unplug the tool before moving, replacing the blade or making adjustments.

PROBLEM	POSSIBLE CAUSES	CORRECTIVE ACTION
Saw will not start.	<ol style="list-style-type: none"><li>1. Saw is not plugged in.</li><li>2. Fuse blown or circuit breaker tripped.</li><li>3. Cord is damaged.</li><li>4. Debris in on/off switch</li></ol>	<ol style="list-style-type: none"><li>1. Plug in saw.</li><li>2. Replace fuse or reset circuit breaker.</li><li>3. Replace power cord.</li><li>4. Remove switch from saw and separate in half. Clean any debris accumulated within.</li></ol>
Does not make accurate 45° and 90° rip cuts.	<ol style="list-style-type: none"><li>1. Positive stop not adjusted correctly.</li><li>2. Tilt angle pointer not set accurately.</li></ol>	<ol style="list-style-type: none"><li>1. Check blade with square and adjust positive stop.</li><li>2. Check blade with square and adjust to zero.</li></ol>
Material pinched blade when ripping.	<ol style="list-style-type: none"><li>1. Rip fence not aligned with blade.</li><li>2. Warped wood, edge against fence is not straight.</li></ol>	<ol style="list-style-type: none"><li>1. Check and adjust rip fence.</li><li>2. Select another piece of wood.</li></ol>
Material binds on riving knife.	<ol style="list-style-type: none"><li>1. Riving knife not aligned correctly with blade.</li></ol>	<ol style="list-style-type: none"><li>1. Check and align riving knife with blade.</li></ol>
Saw makes unsatisfactory cuts.	<ol style="list-style-type: none"><li>1. Dull blade.</li><li>2. Blade mounted backwards.</li><li>3. Gum or pitch on blade.</li><li>4. Incorrect blade for work being done.</li><li>5. Gum or pitch on blade causing erratic feed.</li></ol>	<ol style="list-style-type: none"><li>1. Replace blade.</li><li>2. Turn the blade around.</li><li>3. Remove blade and clean with turpentine and coarse steel wool.</li><li>4. Change the blade.</li><li>5. Clean table with turpentine and steel wool.</li></ol>

**⚠ WARNING**

To avoid injury from accidental starting, always turn switch OFF and unplug the tool before moving, replacing the blade or making adjustments.

<b>PROBLEM</b>	<b>POSSIBLE CAUSES</b>	<b>CORRECTIVE ACTION</b>
Material kicked back from blade.	<ol style="list-style-type: none"><li>1. Rip fence out of adjustment.</li><li>2. Riving knife not aligned with blade.</li><li>3. Feeding stock without rip fence.</li><li>4. Riving knife not in place.</li><li>5. Dull blade.</li><li>6. The operator letting go of material before it is past saw blade.</li><li>7. Miter angle lock knob is not tight.</li></ol>	<ol style="list-style-type: none"><li>1. Align rip fence with miter gauge slot.</li><li>2. Align riving knife with blade.</li><li>3. Install and use rip fence.</li><li>4. Install and use riving knife (with guard).</li><li>5. Replace blade.</li><li>6. Push material all the way past saw blade before releasing work.</li><li>7. Tighten knob.</li></ol>
Blade does not raise or tilt freely.	<ol style="list-style-type: none"><li>1. Sawdust and dirt in elevation/tilting mechanisms.</li></ol>	<ol style="list-style-type: none"><li>1. Brush or blow out loose dust and dirt.</li></ol>
Blade does not come up to speed. Reset trips too easily.	<ol style="list-style-type: none"><li>1. Extension cord too light or too long.</li><li>2. Low house voltage.</li></ol>	<ol style="list-style-type: none"><li>1. Replace with adequate size cord.</li><li>2. Contact your electric company.</li></ol>
Machine vibrates excessively.	<ol style="list-style-type: none"><li>1. Saw not mounted securely to workbench.</li><li>2. Bench on uneven floor.</li><li>3. Damaged saw blade.</li></ol>	<ol style="list-style-type: none"><li>1. Tighten all mounting hardware.</li><li>2. Reposition on flat level surface.</li><li>3. Replace blade.</li></ol>
Does not make accurate 45° and 90° crosscuts.	<ol style="list-style-type: none"><li>1. Miter gauge out of adjustment.</li></ol>	<ol style="list-style-type: none"><li>1. Adjust miter gauge.</li></ol>

## PUSH STICK CONSTRUCTION

- Use good quality plywood or solid wood
- Use 1/2 in. or 3/4 in. material
- Push stick MUST be thinner than the width of material being cut

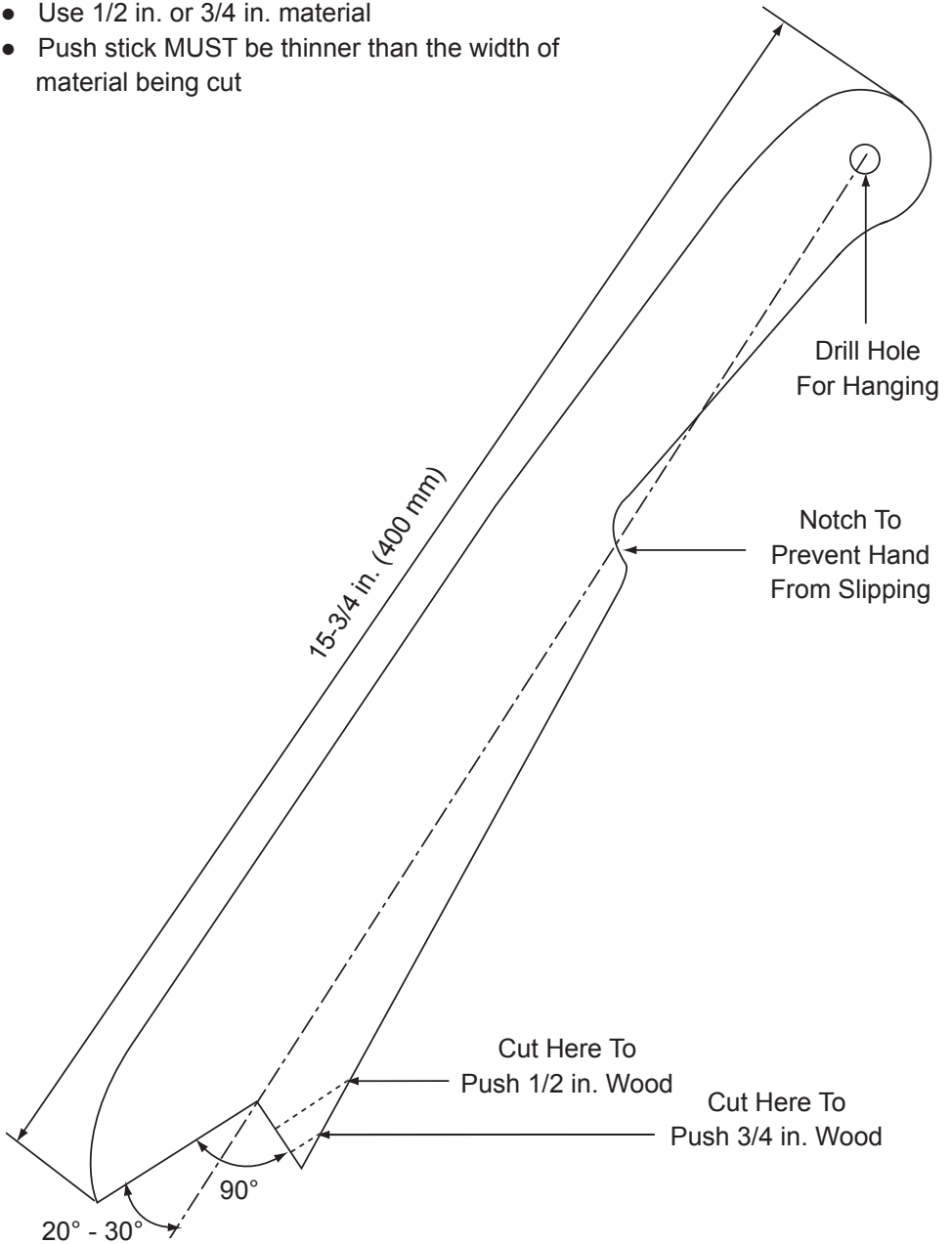

# PARTS LIST

10 IN. JOBSITE TABLE SAW

MODEL NO. 137.054450



**WARNING**

When servicing use only CRAFTSMAN replacement parts. Use of any other parts may create a HAZARD or cause product damage. Any attempt to repair or replace electrical parts on this Table Saw may create a HAZARD unless repair is done by a qualified service technician. Repair service is available at your nearest Sears Service Center. To order replacement parts or schedule service by phone, call 1-888-331-4569.

## PARTS LIST FOR TABLE SAW (A)

I.D. No.	Description	Size	Q'ty	I.D. No.	Description	Size	Q'ty
08VH	CORD CLAMP		1	0JD1	SPRING PIN		1
0901	BUSH		1	0JPJ	HEX. HD. BOLT	M6*1.0-40	1
090Q	PLUNGER HOUSING		1	0JYV	HEX. SOC. HD. CAP BOLT	M6*1.0-16	1
09JK	HEX. WRENCH	4 MM	1	0JZY	HEX. SOC. TRUSS HD. SCREW	M6*1.0-12	1
09XJ	COMPRESSION SPRING		1	0K0X	HEX. HD. SCREW AND WASHER	M6*1.0-16	1
0AW8	SEGMENT GEAR		1	0K2B	HEX. SOC. HD. CAP SCREW	M6*1.0-16	4
0B2B	NEEDLE POINTER		1	0K3E	CR. RE. PAN HD. SCREW & WASHER	M5*0.8-10	1
0B3R	WRENCH		1	0K3H	CR. RE. PAN HD. SCREW & WASHER	M6*1.0-12	2
0B9M	STRAP		1	0K5B	CR. RE. COUNT HD. SCREW	M6*1.0-12	4
0B9P	CLAMP		1	0K6U	CR. RE. TRUSS HD. SCREW	M4*0.7-8	1
0BA1	COMPRESSION SPRING		1	0K71	CR. RE. TRUSS HD. SCREW	M5*0.8-8	1
0BA4	SPACER		1	0K77	CR. RE. TRUSS HD. SCREW	M6*1.0-23	2
0BA9	SPACER		1	0K8C	CR. RE. COUNT HD. TAPPING SCREW	M4*18-10	8
0BAB	SHIM		1	0K9U	HEX. HD. TAPPING SCREW	M5*16-25	4
0BAC	SET NUT		1	0KA4	CR. RE. PAN HD. TAPPING SCREW	M4*16-16	2
0BAE	ARBOR COLLAR		1	0KA6	CR. RE. PAN HD. TAPPING SCREW	M5*12-10	4
0J3P	HEX. WRENCH		1	0KB3	CR. RE. PAN HD. TAPPING SCREW	M4*18-8	2
0J4D	FLAT WASHER	φ5*10-1	4	0KBA	CR. RE. PAN HD. TAPPING SCREW	M5*16-12	4
0J4E	FLAT WASHER	φ6*13-1	1	0KBQ	CR. RE. PAN HD. TAPPING SCREW	M5*16-10	1
0J52	FLAT WASHER	φ16*25-1.2	1	0KC8	CR. RE. TRUSS HD. TAPPING SCREW	M4*16-16	3
0J58	FLAT WASHER	φ5*14-1	4	0KCX	CR. RE. PAN HD PLAIN WASHER TAPPING SCREW	M5*0.8-10	2
0J5C	FLAT WASHER	φ13.8*10-1	1	0KCY	CR. RE. PAN HD PLAIN WASHER TAPPING SCREW	M5*0.8-12	4
0J6K	FLAT WASHER	φ6*30-4	1	0KCF	CR. RE. PAN HD PLAIN WASHER	M5*0.8-16	2
0J6T	FLAT WASHER	3/16*3/4-1/16	4	0KF7	CR. RE. PAN HD. SCREW	M4*0.7-12	2
0J72	FLAT WASHER	1/4*5/8-1/16	1	0KJ0	CAP HD. SQ. NECK BOLT	M6*1.0-16	1
0J74	FLAT WASHER	1/4*5/8-3/32	1	0KJN	CAP HD. SQ. NECK BOLT	M6*1.0-35	1
0J76	FLAT WASHER	1/4*3/4-1/16	1	0KMS	HEX. NUT	M6*1.0 T=5	1
0J78	FLAT WASHER	1/4*1/2-3/32	1	0KQX	NUT	M6*1.0 T=6	1
0J7E	FLAT WASHER	5/16*11/16-1/16	1	0KQY	LOCK NUT	M8*1.25 T=8	1
0J8D	FLAT WASHER	3/8*3/4-5/64	1	0KRQ	SERRATED TOOTHED HEX. FLANGE NUT	M6*1.0 T=6	1
0J95	SPRING WASHER	φ6	1	0KSM	STRAIN RELIEF		1
0JAE	EXTERNAL TOOTH LOCK WASHER	φ4	2	0KTK	STRAIN RELIEF		2
0JAF	EXTERNAL TOOTH LOCK WASHER	φ5	1	0KUW	TERMINAL		1
0JB2	WAVE WASHER	WW-12	1	0KWU	LEAD WIRE ASS'Y		1

**10 IN. JOBSITE TABLE SAW  
PARTS LIST FOR TABLE SAW (B)**

**MODEL NO. 137.054450**

<b>I.D. No.</b>	<b>Description</b>	<b>Size</b>	<b>Q'ty</b>	<b>I.D. No.</b>	<b>Description</b>	<b>Size</b>	<b>Q'ty</b>
0LWC	ROCKER SWITCH		1	2YHQ	DUST COLLECTOR		1
0WPL	SWITCH KEY		1	2YHU	DUST PLATE COVER		1
10JR	LOCATING BAR		1	2YJ0	SPACER		1
10JS	ROLL PIN		1	2ZEJ	PLATE		1
10JU	ANCHOR PLATE		2	302W	FLAT WASHER	φ6*21-3	1
10JV	LOCATING BAR		1	308G	NEEDLE POINTER		1
10K2	BUSH		2	309H	WASHER		1
10K4	PARALLEL PIN		2	30C2	HEX. HD. TAPPING SCREW	M5*16-16	10
10K5	HEX. SOC. HD. CAP BOLT	M5*0.8-8	3	30JU	WARNING LABEL		2
10LF	HEX. NUT	M6*1.0 T=4	2	30NM	SPECIAL BOLT		2
20GJ	BRACKET STOP		1	31DB	TABLE		1
212M	LEAD WIRE ASS'Y		1	32V4	SWITCH BOX ASS'Y		1
213B	SPACER		4	33F6	MOTOR ASS'Y		1
21CX	FOLLOWER PLATE		1	34RC	HANDLE		1
239T	CR. RE. PAN HD. TAPPING & WASHER SCREW	M5*0.8-16	4	3A4E	EXTENSION TABLE		1
23PP	BLADE		1	3A4F	SET PLATE		2
25AP	HEX. SOC. HD. CAP BOLT	M6*1.0-25	1	3A4G	RACK		1
262S	POWER CORD CLAMP		2	3EWU	HANDLE		1
27JR	HEX. SOC. SET SCREW	M5*0.8-6	4	3EXA	RIVING KNIFE		1
28A0	POWER CABLE		1	3F49	CIRCUIT BREAKER SWITCH		1
28CK	POWER CABLE ASS'Y		1	3FAT	ANTI-KICKBACK PAWL'S ASS'Y		1
28EX	NEEDLE POINTER		1	3FHW	FRONT SIDE COVER (L)		1
29R9	CUSHION		1	3FJW	FRONT SIDE COVER (R)		1
2A48	HEX. HD. SCREW & WASHER	M5*0.8-16	7	3G21	CLAMP HANDLE ASS'Y	KR#+6#	1
2BNW	SEAT		2	3G2Q	TILTING SCALE		1
2BNX	SHAFT		1	3G2W	WARNING LABEL		1
2CFL	LOCATING BAR		1	3G2X	WARNING LABEL		1
2E3K	CR. RE. ROUND WASHER HD. SCREW	M5*0.8-10	2	3G3X	WARNING LABEL		1
2RVH	WHEEL		1	3GYA	HANDLE		2
2RVJ	CLAMPER BRACKET		1	3H1M	HANDLE BAR ASS'Y	6#	1
2RVM	GEAR		1	3H2Z	PUSH STICK	KR#	1
2RVP	SET PLATE		1	3H3V	LOCKING HANDLE ASS'Y	KR#+6#	1
2RVR	GUIDE CLAMP		4	3H67	BLADE GUARD ASS'Y		1
2RVW	RETAINING CLIP		1	3H6A	MITER GAUGE ASS'Y		1
2RW6	SET PLATE		1	3SJ4	RAIL		1
2SE0	ANCHOR PLATE		1	3SJ5	RAIL		1
2SJU	SPACER		1	3SJ6	RACK		1
2T6E	CLAMP ASS'Y		1	3SKZ	BODY SHELL	KQ#	1
2TDO	COLLAR		1	3SL1	LOCKING HANDLE ASS'Y	KR#+6#	1
2TDD	WORM		1	3SMB	RIP FENCE ASS'Y		1
2TDL	FLAT WASHER		1	3SXX	LABEL		1
2TLZ	POINTER BRACKET		1	3SXX	TRADEMARK LABEL		1
2UET	HEIGHT REGULATING BOLT ASS'Y		1	3SXZ	CAUTION LABEL		1
2WVR	LOCKING ROD		1	3SY0	SCALE		1
2WVT	REAR SIDE COVER		2	3T01	INSTRUCTION MANUAL		1
2YEY	BODY		1	3T03	SCALE ASS'Y		1
2YF4	RETAINING CLIP		1	PQ10	TABLE INSERT ASS'Y		1
2YGQ	RETAINING CLIP		2				
2YGT	ANGLE ROD		1	*2YTV	DADO INSERT PLATE (not included)		

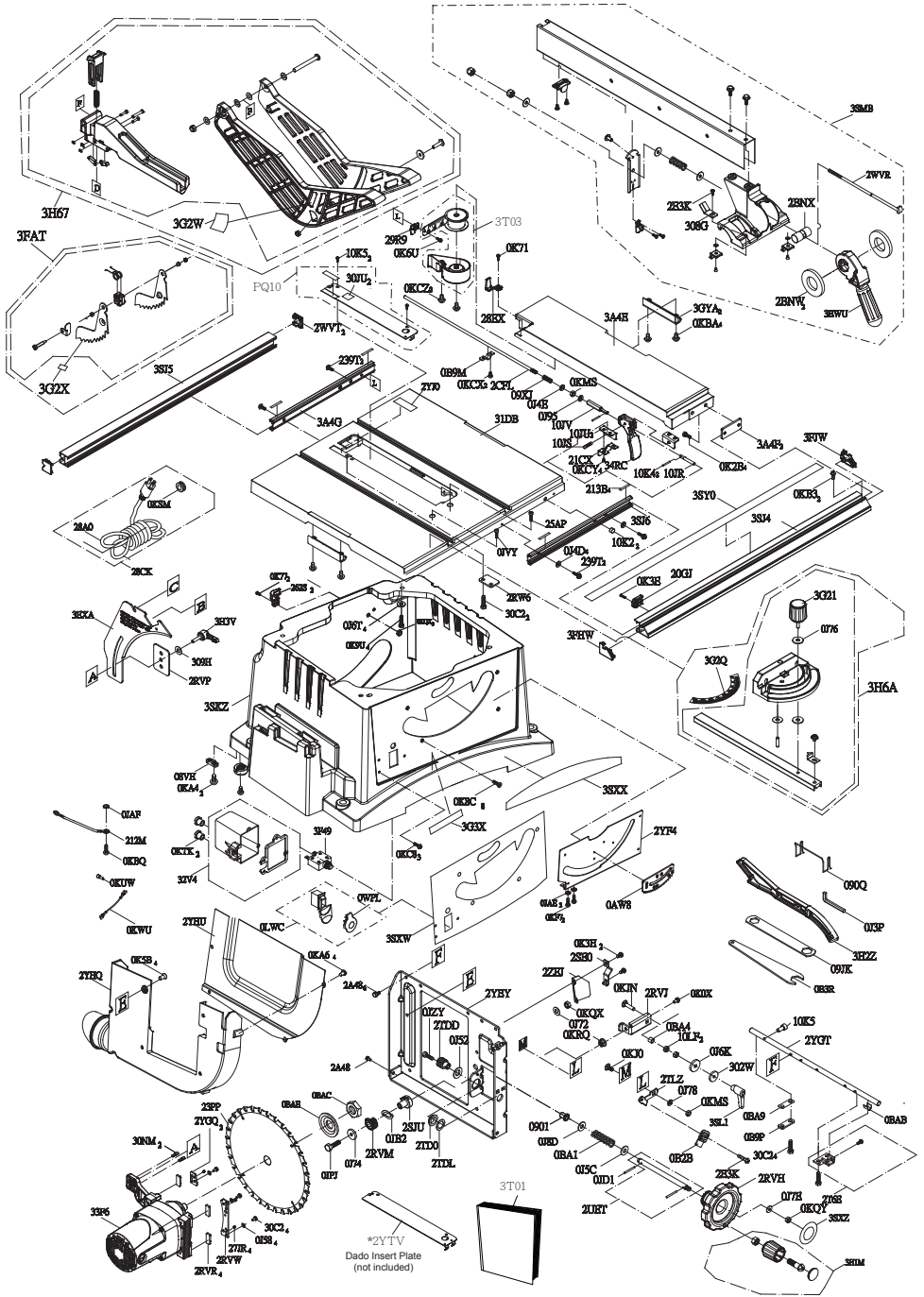

**10 IN. JOBSITE TABLE SAW  
PARTS LIST FOR MOTOR**

**MODEL NO. 137.054450**

I.D. No.	Description	Size	Q'ty
0HX9	NEEDLE BEARING		1
0JX3	HEX. SOC. SET SCREW	M5*0.8-8	2
0KCN	CR. RE. PAN HEAD TAPPING & WASHER SCREW	M5*12-50	2
0KTK	STRAIN RELIEF		1
0QFE	BRUSH COVER		2
0QFF	CARBON BRUSH ASS'Y		2
0QFG	BRUSH HOLDER ASS'Y		2
2RPP	FLOW GUIDE		1
2RWS	CR. RE. COUNTER-SUN HEAD SCREW	M5*0.8-10	2
2RXC	LABEL		1
2YF5	BRACKET		1
2YH8	MOTOR COVER	6#	1
30L3	CUTTER SHAFT ASS'Y		1
30L5	ARMATURE ASS'Y		1
33F7	FIELD ASS'Y		1
3NYP	CR. RE. PAN HD. SCREW & WASHER	M5*0.8-55	4
3NYV	WAVE WASHER	BWW-608	1

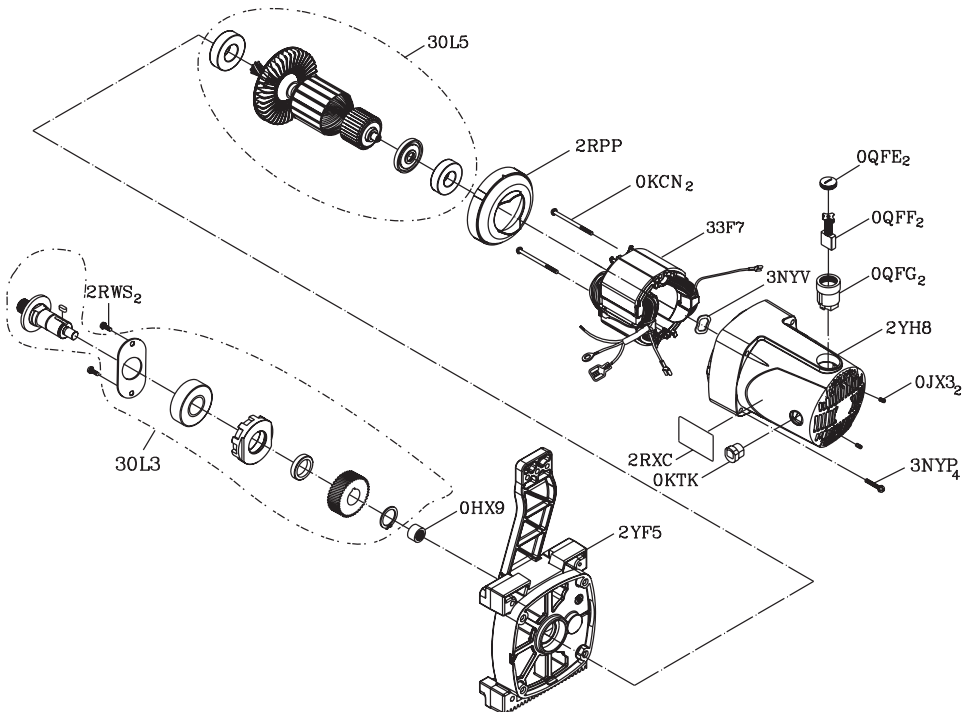



# 10 IN. JOBSITE TABLE SAW

## PARTS LIST FOR STAND

MODEL NO. 137.054450

I.D. No.	Description	Size	Q'ty	I.D. No.	Description	Size	Q'ty
0J4E	FLAT WASHER	φ6*13-1	2	3M73	BUMPER	6#	2
0J4R	FLAT WASHER	φ10*20-3	1	3M75	ARC WASHER		28
0J5G	FLAT WASHER	φ8*18-1.5	4	3QKG	ADJUSTABLE FOOT		2
0JPS	HEX. HD. BOLT	M8*1.25-45	4	3SHB	STIFFENER ASS'Y		1
0JQD	HEX. HD. BOLT	M8*1.25-50	3	3SHC	STIFFENER ASS'Y		1
0JUR	HEX. SOC. HD. CAP BOLT	M6*1.0-50	2	3SHD	ELBOW ASS'Y		1
0JZS	HEX. SOC. TRUSS HD. SCREW	M4*0.7-12	1	3SHR	RETAINING CLIP		2
0K00	HEX. SOC. TRUSS HD. SCREW	M6*1.0-20	2	3SHS	LINK PLATE		2
0K03	HEX. SOC. TRUSS HD. SCREW	M8*1.25-15	4	3SHT	RETAINING CLIP		1
0KD4	CR. RE. PAN HD. SCREW	M6*1.0-10	2	3SHU	PEDAL		1
0KMQ	HEX. NUT	M4*0.7 T=3.2	1	3SHV	ROD		1
0KMT	HEX. NUT	M8*1.25 T=5	2	3SHW	SUPPORT TUBE		1
0KQX	NUT	M6*1.0 T=6	12	3SHX	SUPPORT TUBE		1
0KQY	LOCK NUT	M8*1.25 T=8	13	3SHY	HANDLE		1
0KQZ	NUT	M10*1.5 T=10	1	3SHZ	HANDLE		1
0WRG	HEX. HD. BOLT	M8*1.25-100	4	3SJD	TORSION SPRING		1
288R	HEX. HD. BOLT	M8*1.25-55	2	3SM5	ELBOW ASS'Y		1
2FUD	COLLAR		8	3SM6	ELBOW ASS'Y		1
2HDS	WING NUT	M8*1.25-2B	2	3SM7	ELBOW ASS'Y		1
2JQS	CR. RE. TRUSS HD. SCREW	M6*1.0-50	6	3SM8	ELBOW ASS'Y		1
2X6Q	END CAP		2	3SMA	FLOOR WHEEL ASS'Y		2
2XGE	SLEEVE		1	3SXY	CAUTION LABEL		1
39RP	FLOOR WHEEL ASS'Y		1	3T6E	SPACER		2
3F63	GRIP		2	3T6T	CR. RE. TRUSS HD. RD. NECK SCREW	M6*1.0-10	2
3F9Y	HEX. HD. BOLT	M10*1.5-110	1	3UX6	WARNING LABEL		2
3G2Z	WARNING LABEL		1	Y2GR	COMPRESSION SPRING		1

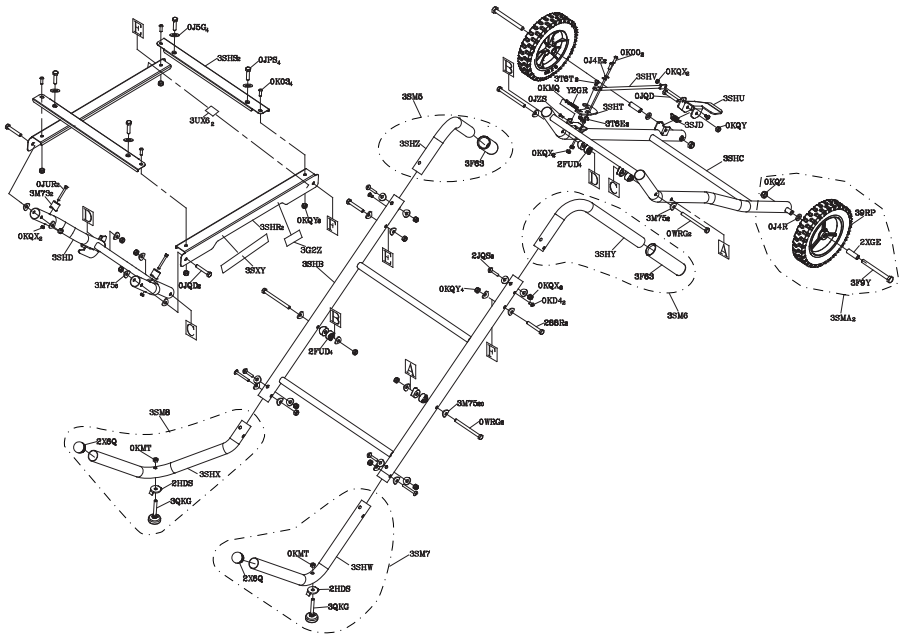

# REPAIR PROTECTION AGREEMENTS

*Congratulations on making a smart purchase. Your new Craftsman® product is designed and manufactured for years of dependable operation. But like all products, it may require repair from time to time. That's when having a Repair Protection Agreement can save you money and aggravation.*

## **Here's what the Repair Protection Agreement\* includes:**

- ☑ **Expert service** by experienced service technicians trusted in millions of homes every year.
- ☑ **Unlimited service and no charge** for parts and labor on all covered repairs.
- ☑ **Product replacement** up to \$1500 if your covered product can't be fixed.
- ☑ **Discount of 25%** from regular price of service and related installed parts not covered by the agreement.
- ☑ **Fast help by phone** – phone support from a service agent on all products to help troubleshoot problems. Think of us as a “talking owner's manual.”

Once you purchase the Repair Protection Agreement, a simple phone call is all that it takes for you to schedule service. You can call anytime day or night.

The Repair Protection Agreement is a risk-free purchase. If you cancel for any reason during the product warranty period, we will provide a full refund. Or, a prorated refund anytime after the product warranty period expires. Purchase your Repair protection Agreement today!

**Some limitations and exclusions apply. For prices and additional information call 1-800-827-6655.**

## **Sears Installation Service**

*For Sears professional installation of home appliances, garage door openers, water heaters, and other major home items, call **1-888-331-4569**.*

# NOTES

# NOTES