



# Zoneline® AIR CONDITIONER

**SAFETY INFORMATION** .....3

**USING THE ZONELINE**

Controls .....6

Air Direction .....7

To Remove the Room Cover .....7

Ventilation Control.....7

Auxiliary Controls.....8

Remote Thermostat.....12

Makeup Air .....13

**CARE AND CLEANING**

Base Pan .....14

Outdoor Coils .....14

Room Cover and Case.....14

Ventilation Filter.....15

Air Filters.....15

**INSTALLATION INSTRUCTIONS**

Preparation .....16

Replacing an Existing Unit .....17

Electrical Connection.....18

Installing the Zoneline.....21

Optional Drain Kit .....23

**TROUBLESHOOTING TIPS**..... 24

Normal Operating Sounds ..... 26

**CONSUMER SUPPORT**

Ownership Registration.....27

Warranty .....31

Consumer Support.....32

## OWNER'S MANUAL

AZ45  
AZ65

### ESPAÑOL

For a Spanish version of this manual, visit our Website at [www.zoneline.com](http://www.zoneline.com).

Para consultar una version en español de este manual de instrucciones, visite nuestro sitio de internet [www.zoneline.com](http://www.zoneline.com).

### FRANÇAIS

For a French version of this manual, visit our Website at [www.zoneline.com](http://www.zoneline.com).

Pour un version français de ce manuel d'utilisation, veuillez visiter notre site web à l'adresse [www.zoneline.com](http://www.zoneline.com).

Write the model and serial numbers here:

Model # \_\_\_\_\_

Serial # \_\_\_\_\_

Find these numbers on a label behind the room cover on the base pan.

## **THANK YOU FOR MAKING GE APPLIANCES A PART OF YOUR HOME.**

---

Whether you grew up with GE Appliances, or this is your first, we're happy to have you in the family.

We take pride in the craftsmanship, innovation and design that goes into every GE Appliances product, and we think you will too. Among other things, registration of your appliance ensures that we can deliver important product information and warranty details when you need them.

Register your GE appliance now online. Helpful websites and phone numbers are available in the Consumer Support section of this Owner's Manual. You may also mail in the pre-printed registration card included in the packing material.



**GE APPLIANCES**

# IMPORTANT SAFETY INFORMATION

## READ ALL INSTRUCTIONS BEFORE USING THE APPLIANCE

### WARNING

For your safety, the information in this manual must be followed to minimize the risk of fire or explosion, electric shock, or to prevent property damage, personal injury, or loss of life.

## SAFETY PRECAUTIONS

- This Zoneline must be properly installed in accordance with the Installation Instructions before it is used. See the Installation Instructions in the back of this manual.
- Immediately replace all electric service cords that have become frayed or otherwise damaged. A damaged power supply cord must be replaced with a new power supply cord obtained from the manufacturer and not repaired. Do not use a cord that shows cracks or abrasion damage along its length or at either the plug or connector end.
- Unplug or disconnect the Zoneline at the fuse box or circuit breaker before making any repairs.

**NOTE:** We strongly recommend that any servicing be performed by a qualified individual.

- These R410A air conditioning systems require contractors and technicians to use tools, equipment and safety standards approved for use with this refrigerant. **DO NOT use equipment certified for R22 refrigerant only.**

### Replacing an existing unit?

For details, see the Installation Instructions in this manual.

## READ AND SAVE THESE INSTRUCTIONS

# CONSIGNES DE SÉCURITÉ IMPORTANTES

## LISEZ TOUTES LES INSTRUCTIONS AVANT L'UTILISATION

### AVERTISSEMENT

Pour votre sécurité, veuillez observer les consignes de ce manuel afin de réduire le risque d'incendie, d'explosion, de choc électrique, de dommages à la propriété ou de blessures, graves ou fatales.

## MESURES DE SÉCURITÉ

- Avant son utilisation, ce climatiseur Zoneline doit être installé correctement en conformité avec les instructions d'installation. Consultez les instructions d'installation au dos de ce manuel.
- Remplacez immédiatement tous les cordons électriques usés ou autrement endommagés. Un cordon électrique endommagé ne doit pas être réparé, il doit être remplacé par un cordon neuf acquis auprès du fabricant. N'utilisez pas un cordon qui présente des fissures ou des marques d'abrasion sur sa longueur, sa fiche ou sa connexion.
- Débranchez le climatiseur Zoneline ou coupez le courant à la boîte de fusibles ou au disjoncteur avant d'effectuer une réparation.

**REMARQUE:** Nous recommandons vivement que les réparations soient effectuées par une personne qualifiée en la matière.

- Les outils, les équipements et les normes de sécurité utilisés par les entrepreneurs et les techniciens doivent être approuvés en fonction du fluide frigorigène dont le système de climatisation R410A du Zoneline est équipé. **N'UTILISEZ PAS d'équipements certifiés relativement au fluide frigorigène R22 seulement.**

### **Vous remplacez un climatiseur existant?**

Pour de plus amples renseignements, veuillez consulter les instructions d'installation de ce manuel.

## LIRE ET CONSERVER CES INSTRUCTIONS

# INFORMACIÓN IMPORTANTE DE SEGURIDAD

## LEA TODAS LAS INSTRUCCIONES ANTES DE USAR

### ADVERTENCIA

Para su seguridad, se debe seguir la información de este manual para minimizar el riesgo de incendio o explosión, descargas eléctricas, o para evitar daños a la propiedad, lesiones personales o la muerte.

## PRECAUCIONES DE SEGURIDAD

- Antes de iniciar su uso, el acondicionador de aire Zoneline debe instalarse correctamente según las Instrucciones de instalación. Ver las Instrucciones de instalación en la parte trasera de este manual.
- Reemplace inmediatamente todos los cables eléctricos que se haya pelado o que se hayan dañado de alguna otra manera. Un cable de corriente dañado no debe repararse, sino que debe ser sustituido por uno nuevo que se adquiera del fabricante. No use un cable eléctrico que muestre evidencias de deterioro o daños de abrasión en su superficie o en cualquiera de sus enchufes o extremos.
- Desenchufe o desconecte el Zoneline desde la caja de fusibles o el disyuntor antes de realizar cualquier tipo de reparación.

**NOTA:** Recomendamos enérgicamente que cualquier servicio llevado a cabo en este equipo lo realice un individuo calificado.

- Los sistemas de acondicionador de aire R410A requieren que los contratistas y técnicos utilicen herramientas, equipamiento y normas de seguridad aprobadas para su uso con este refrigerante. **NO utilice equipamiento certificado sólo para refrigerante R22.**

### ¿Desea reemplazar una unidad ya instalada?

Para más detalles, ver las Instrucciones de instalación en este manual.

## LEA Y GUARDE ESTAS INSTRUCCIONES

# Controls

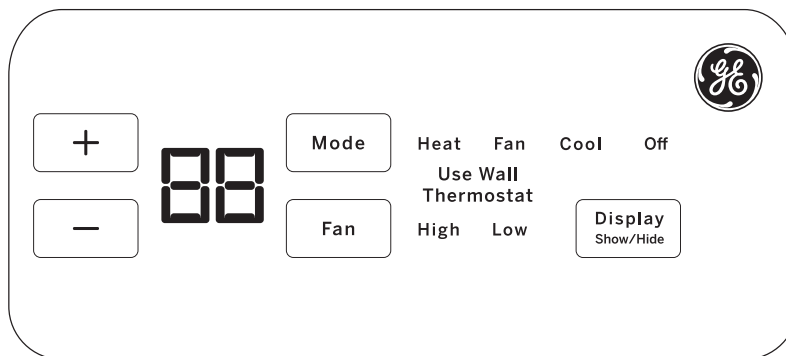

## Temp Control

The temp control is used to maintain the room temperature. The system will cycle on and off to keep the room at the same level of comfort.

Press the + pad to raise the temperature.

Press the - pad to lower the temperature.

**NOTE:** The display shows the set temperature, not the room temperature.

## Fan, Mode and Operation Control

**FAN**—Sets the fan operation for **HIGH** or **LOW**.

**MODE—COOL**—For cooling

**FAN**—For fan-only operation

**HEAT**—For heating

**OFF**—Turns the unit off. Power remains connected to the Zoneline. The Freeze/Heat Sentinel features still function if active. See the *Freeze/Heat Sentinel* section on page 8.

**USE WALL THERMOSTAT**— This LED will light up when the unit is controlled by a wall thermostat. See page 9 for details.

## Quick Heat Recovery

Activates each time the thermostat is switched from **OFF** or **COOL** mode to **HEAT** mode. Electric heaters are energized until the thermostat set point is reached. On heat pump models, the heat pump operation will resume at the next call for heat.

## About Your Heat Pump (AZ65 only)

Heat pumps can save money by removing heat from the outside air—even when the outside temperature is below freezing—and releasing that heat indoors.

To get the best energy performance from your heat pump, don't change the room thermostat by more than one degree at one time. Raising the heat setting 2–3 degrees will cause the Zoneline to use its electric heating elements in order to reach the new temperature setting quickly.

The electric heating elements use more electricity than heat pumps and cost more to operate.

## Control Lock Out

The control panel can be locked out to prevent users from changing the operation mode of the unit.

While the unit is in the desired operating mode, press and hold the DISPLAY SHOW/HIDE button for 10 seconds to lock the control and the desired setting. Any key press after that will result in the mode LED and temperature that was locked to flash 5 times and then go dormant.

To unlock the control lock out feature, press the DISPLAY SHOW/HIDE button for 10 seconds to unlock and resume normal operation.

**NOTE:** The temperature display will flash if the control panel is locked (see *Control Lock Out* section).

**NOTE:** When switching between modes, it may take several minutes to completely change operation.

There is a 3-minute minimum compressor run time at any setting to prevent short cycling.

The fans start before the compressor and stop after the compressor cycles off.

When the outdoor temperature is lower than 25°F, heat is provided by the electric heater instead of by the heat pump.

# Using the Zoneline

## To Remove the Room Front

Additional controls are located behind the room cover.

**To remove:** Pull out at the bottom to release it from the holding tabs on the sides (1). Then lift up (2).

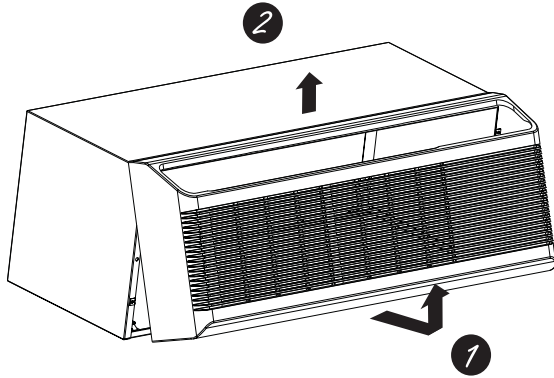

**To replace:** Align and place the top rail of the room cover over the chassis (1). Push inward at the bottom until it snaps into place (2).

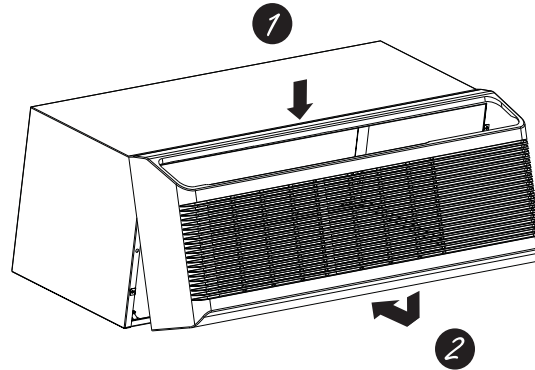

## Air Direction

To change the air direction, remove the room cover. Remove the 4 louver screws that hold the louver insert in place. Rotate the louver 180°, reinstall and replace the screws and the room cover.

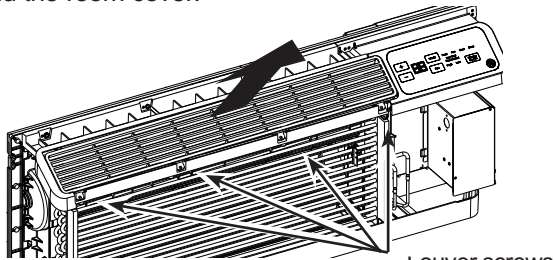

Louver screws  
Factory Shipped Louver Orientation  
(airflow @ 45° from horizontal)

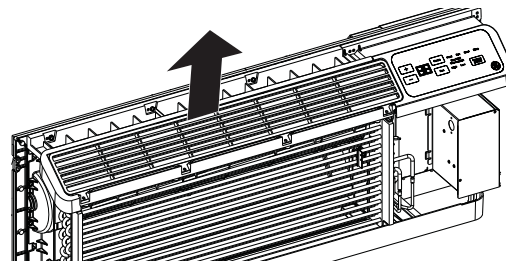

Modified Louver Orientation  
(airflow @ 65° from horizontal)

## Ventilation Control\*

**NOTE:** Two shipping screws must be removed from the vent door before use. See the *Installation Instructions* in the back of this manual. If you do not plan to use the ventilation feature, leave the two screws in place.

The ventilation control lever is located at the lower left side of the Zoneline unit, behind the room cover. The position of the lever can be adjusted with the wing nut.

When set at the closed position, only the air inside the room is circulated and filtered.

When set in an open position, some outdoor air will be drawn into the room. This will reduce the heating or cooling efficiency.

**Energy Tip:** Keep the vent control in the closed position to prevent unconditioned air from entering the room.

\* Not on Make Up Air Module

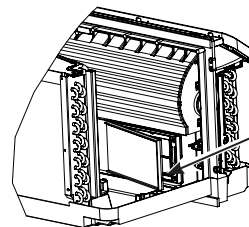

Remove the shipping screws (if operation is desired)

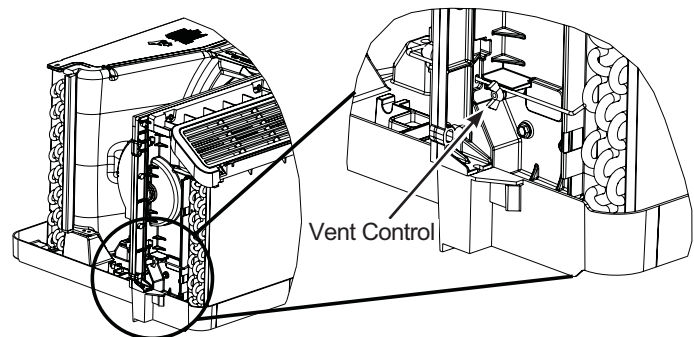

Vent Control

# Auxiliary controls on your Zoneline

## Auxiliary Controls - Aux Set Button

While the unit is preset to what most customers prefer, the auxiliary controls located behind the room cover, below the control panel.

Press the red **AUX SET** button to lock in the selection, and exit AUX SET mode.

Remove the room cover. See the To Remove the Room Cover section.

If the owner modifies the auxiliary controls it is then the owner is responsible for ensuring the auxiliary controls are set to the desired function. There are 10 different modes that can be set using the auxiliary set button.

To change operating or set up parameters, first go to the mode control and turn the unit off, then, press the red **AUX SET** button (“AU” appears on the display).

Press the mode button on the control pad until the first digit in the display shows the number corresponding to the mode you are choosing and the correct HEAT/COOL LED is lit.

Press the +/- button to make the mode setting selection where applicable (shown in the second digit of the display).

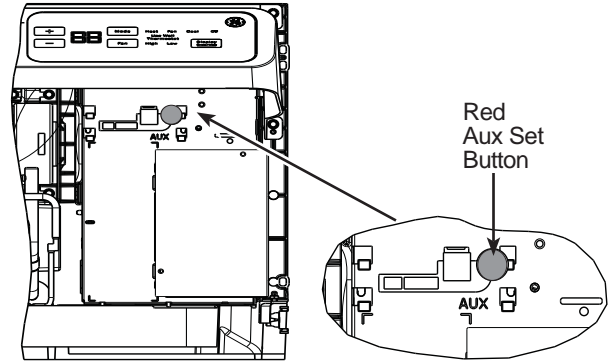

Press "Aux Set"		Press "Aux Set"		Press "Aux Set for Digital Makeup Air Mode"	
A First Digit	U Second Digit	A First Digit	U Second Digit	A First Digit	U Second Digit
Press "Mode"	Press +/-	Press "Mode"	Press +/-	Press "Mode"	Press +/-
1 Smart Fan <small>HEAT COOL</small>	U - Cycle / N - Continue	5 Temperature Limit <small>HEAT COOL</small>	U - Off / N - On (Cool/Heat) / A - On (Auto Change Over)	0 Makeup Air Mode	U - Disable / N - Enable
2 Temperature Display	F / C	6 Class 2 Mode		1: 25CFM 4: 40CFM	
3 Sentinel <small>HEAT COOL</small>	U - Off / N - On	7 Duct Mode		2: 30CFM 5: 45CFM	
4 Constant Fan	U - Off / N - On	8 All I2R Mode (AZ65 Only)		3: 35CFM 6: 50CFM	
		9 Boost Heat (AZ65 Only)			

293D2203P002

### MODE 1 Smart Fan—Cooling/Heating

Press **MODE** until a 1 appears in the first digit of the display for **Smart Fan** cool mode. The **COOL** LED light on the main control will be on. To change to heat mode, press **MODE** again. The **HEAT** LED light on the main control will be lit.

Press the - pad to set the indoor fan to cycle on/off in the heating or cooling mode selected “□.”

Press the + pad to set the indoor fan to run continuously in the heating or cooling mode selected “■.”

Press **AUX SET** to confirm your selection and exit **AUX SET** mode, or press **MODE** to continue setting other functions.

The default setting for Mode 1 is as follows:  
Cooling: Continuous (ON)  
Heating: Cycle (OFF)

**\*Note:** In cyclic cooling mode, the indoor fan will activate occasionally to verify air temperature in the room. In cyclic heating mode, the fan will continue to operate for several seconds after the heating function has stopped in order to increase unit efficiency.



Cool

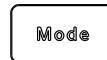
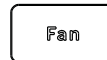

Cool



Heat



Heat





# Auxiliary controls on your Zoneline

## MODE 2 Fahrenheit / Celsius

This feature allows the individual to switch the temperature units between Fahrenheit and Celsius on the display.

Press **MODE** until a 2 appears in the first digit of the display for Fahrenheit/Celsius mode.

Press the - pad to select Celsius or the + pad to select Fahrenheit. The individual will see an F for Fahrenheit or a C for Celsius in the second digit of the display based on the selection.

The default setting for Mode 2 is Fahrenheit.



## MODE 3 Freeze Sentinel/Heat Sentinel

With power to the unit and **Freeze Sentinel** activated, the unit automatically provides heat without user interface. This prevents potential plumbing damage by turning the heater and indoor fan ON at 41°F and then OFF once the room temperature reaches 46°F.

When **Heat Sentinel** is activated, the unit automatically provides cooling without user interface. This prevents an excessively hot room by turning the air conditioner ON at 85°F and then OFF once the room temperature reaches 80°F.

Press **MODE** until a 3 appears in the first digit of the display for **Freeze Sentinel** mode. The **COOL** LED light on the main control will be on. Press **MODE** again to change to the **Heat Sentinel**. The **HEAT** LED light on the main control will be on. Press the - pad for OFF "⏏" or the + pad for ON "⏏". This is shown in the second digit of the display. Press **AUX SET** to lock in your selection, and exit **AUX SET** mode, or press **MODE** to continue setting other functions.

In the default setting for Mode 3, **Heat Sentinel** is off, **Freeze Sentinel** is on.

**NOTE:** These functions are active whenever the unit is plugged in, even if the unit is turned off.

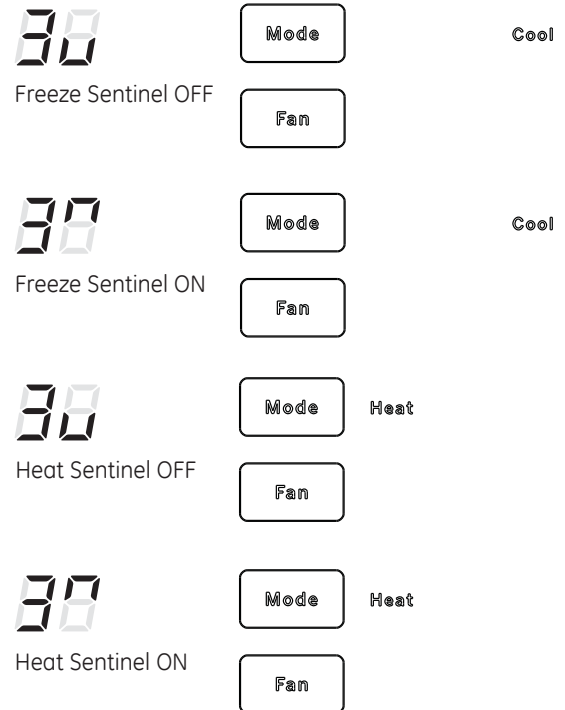

## MODE 4 Constant ON Fan

Press **MODE** until a 4 appears in the first digit of the display to set the fan to run continuously at high speed - **even if the unit is turned off**.

Press the - pad for OFF "⏏" or the + pad for ON "⏏." This is shown in the second digit of the display.

Press **AUX SET** to lock in your selection and exit **AUX SET** mode, or press **MODE** to continue setting other functions.

The default setting for Mode 4 is OFF.



# Auxiliary controls on your Zoneline

## MODE 5 Temperature Limiting

Temperature limiting is a feature that reduces energy costs by limiting the lowest temperature that can be obtained in cooling and the highest temperature that can be obtained in heating.

Press **MODE** until a 5 appears in the first digit of the display for **Temperature Limiting** cool mode. The **COOL** LED light on the main control will be lit. To change to heat mode, press **MODE** again and the **HEAT** LED light on the main control will be lit.

To set the temperature limits, press the + or - pad . The second digit of the display will be between 0 and 7 depending on the limit you want to set. The chart shows the limits available. Press **AUX SET** to lock in your selection and exit **AUX SET** mode, or press **MODE** to continue setting other functions.

Temperature limits—Cool	Temperature limits—Heat
0 = 60°F to 85°F	0 = 60°F to 65°F
1 = 64°F to 85°F	1 = 60°F to 70°F
2 = 66°F to 85°F	2 = 60°F to 72°F
3 = 68°F to 85°F	3 = 60°F to 74°F
4 = 70°F to 85°F	4 = 60°F to 76°F
5 = 72°F to 85°F	5 = 60°F to 78°F
6 = 74°F to 85°F	6 = 60°F to 80°F
7 = 76°F to 85°F	7 = 60°F to 85°F

The default setting for Mode 5 is as follows:  
Cool: 2 (66°F to 85°F)  
Heat: 5 (60°F to 78°F)

52

Mode

Cool

Fan

Temperature Limiting Cool – Limit 2

55

Mode

Heat

Fan

Temperature Limiting Heat – Limit 5

## MODE 6 Use Wall Thermostat

Setting this mode to ON will allow the unit to operate with a Class 2 Remote Control Wall Thermostat. Press **MODE** until a 6 appears in the first digit of the display for **Class 2** mode.

The default setting for Mode 6 is OFF.

Press the + pad to turn the option ON “□” for “standard cool/heat” thermostats. Press the + pad again to turn the option ON “R” for “auto change over” thermostat. You may press the - pad to return to the previous setting. Press **AUX SET** to lock in your selection and exit **AUX SET** mode, or press **MODE** to continue setting other functions.

When this mode is active, the display will show “Use Wall Thermostat” when any key is pressed.

60

Class 2 OFF

6R

Class 2 ON  
(Cool/Heat)

6□

Class ON  
(Auto Change Over)

## MODE 7 Duct Mode

This setting is used when the unit is installed with a duct adapter kit. If the unit is ducted, the Duct Mode needs to be set to ON. This increases the fan speed to ensure proper circulation.

Press **MODE** until a 7 appears in the first digit of the display. Press the + or - pad to set this switch to OFF “□” or ON “□.” This is shown in the second digit of the display. Press **AUX SET** to lock in your selection and exit **AUX SET** mode.

For Model AZ65, press **MODE** to continue setting other functions. Pressing **MODE** on Model AZ45 will return you to **AUX SET** mode and an “AU” will appear in the display.

The default setting for Mode 7 is OFF.

70

Duct Mode OFF

7□

Duct Mode ON

# Auxiliary controls on your Zoneline

---

## **MODE 8** All-Electric Heat (AZ65 only)

This electric heat option functions only on the AZ65 model. When this option is ON “**□**,” heat pump operation is locked out, causing the unit to provide only electric resistance heat.

To set **All-Electric Heat** option, press **MODE** until an 8 appears in the first digit of the display. Press the + or - pad to set this switch to OFF “**□**” or ON “**□**.” This is shown in the second digit of the display.

Press **AUX SET** to lock in your selection and exit **AUX SET** mode, or press **MODE** to continue setting other functions.

The default setting for Mode 8 is OFF.



All-Electric Heat OFF



All-Electric Heat ON

## **MODE 9** Heat Boost (AZ65 only)

When **Heat Boost** is ON and outside temperatures are between 25°F and 46°F, supplementary electric heat to the heat pump operation to help maintain a consistent, comfortable room temperature.

To set Heat Boost, press **MODE** until a 9 appears in the first digit of the display. Press the + or - pad to set this switch to OFF “**□**” or ON “**□**.” This is shown in the second digit of the display. Press **AUX SET** to lock in your selection and exit **AUX SET** mode.

The default setting for Mode 9 is OFF.



Heat Boost OFF



Heat Boost ON

## **MODE 0** Digital Makeup Air Module Fan Speed

Press **MODE** until a 0 appears in the first digit of the display for the Digital Makeup Air mode. To turn off the module or change the fan speeds, press the + or - pad. 00 indicates the module is off. 01= module on with fans set at 25cfm, 02 = module on with fans set at 30cfm, etc.

The default setting for Mode 0 is ON with a fan speed of 35 cfm “**3**”

## **MODE E** Digital Makeup Air Module Occupancy

To enable occupancy detection, press **MODE** until an E appears in the first digit of the display. Press the + or - pad to set occupancy detection to OFF “**□**” or ON “**□**”.

The default setting for Mode E is OFF “**□**”.

# Auxiliary controls on your Zoneline

## Auxiliary Controls - Terminal Connections

The auxiliary control terminal connects are located behind the room cover beneath the access cover.

1. Turn off and unplug the unit.
2. Remove the room cover. See the To Remove the Room Cover section.
3. To make wiring connections, insert the connectors into the appropriate terminals on the control box.
4. After all desired connections have been made, replace the access cover and room cover.

The owner is responsible for making all connections and setting the appropriate **AUX SET** mode.

### NOTICE:

Improper wiring may damage the Zoneline electronics. No common busing is permitted. Damage or erratic operation may result. A separate wire pair must be run from each separate controlling switch to each individual Zoneline.

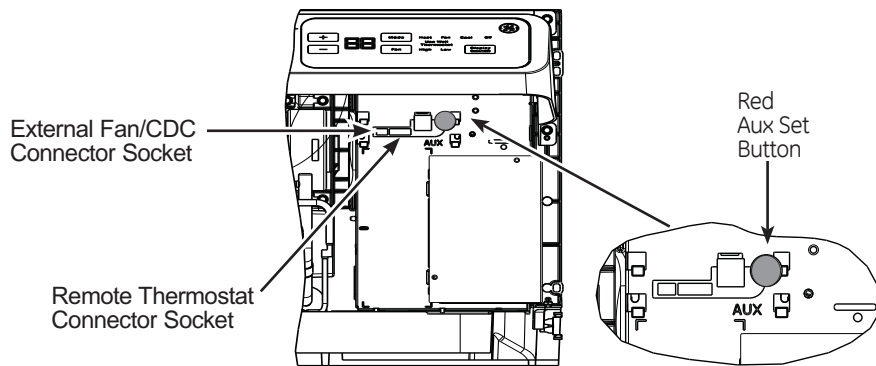

### External Fan (Field Installed)

When connected, an auxiliary or external fan can be controlled with the indoor fan motor on the Zoneline. Connections provide 24 V AC to energize a remote relay.

The RAKCDC accessory must be used when using an external fan.

### Central Desk Control (Field Supplied)\*

The Central Desk Control is a feature that allows the unit to be made operable/inoperable from a remote location. Operation of the feature requires that an ON-OFF switch at the remote location be wired to the two CDC terminals on the control panel of the Zoneline. When the remote switch is CLOSED, the unit cannot be operated in the Fan, Cool, or Heat modes by the control. The Freeze Sentinel and the Heat Sentinel features remain operable. When the remote switch is Open, the unit is fully operable by control.

The RAKCDC accessory must be used with a central desk control system. No "Common Busing" is permitted.

\* It should be noted that CDC cannot be used on DBM and EBM models when occupancy is enabled.

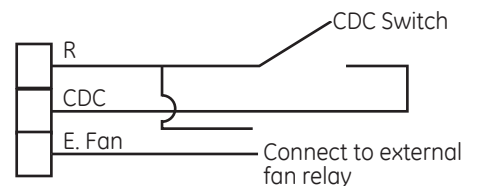
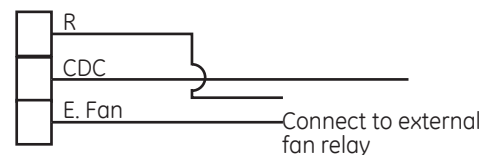
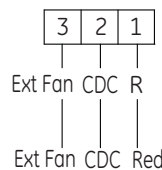
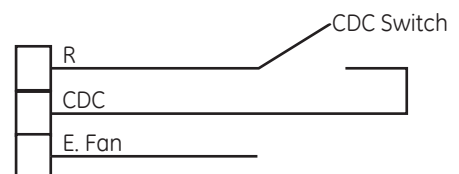

# Auxiliary controls on your Zoneline

## Remote Thermostat

The Remote Thermostat Connectors are included with each Zoneline.

When connected to a remote thermostat, the indoor air temperature sensing is shifted from the unit to the remote thermostat. For this reason, the units will operate slightly differently when connected to a remote thermostat. The following chart shows the unit operation when connected to a remote thermostat.

**IMPORTANT:** The Zoneline thermostat connections provide 24 V AC only.

If using a digital/electronic wall thermostat, you must set it to the 24 V AC setting. See the Installation Instructions for the wall thermostat.

**NOTICE:**

Damage to a wall thermostat or to the Zoneline electronics can result from improper connections. Special care must be used in connecting the wires. No line voltage connections should be made to any circuit. Isolate all wires in building from line voltage.

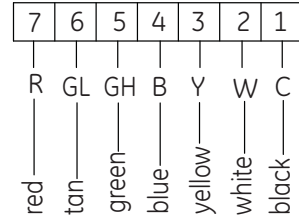

Feature	Heat Pump	Electric Heat
Indoor Frost Control	Yes	Yes
Freeze Sentinel	Yes	Yes
Electronic Temperature Limiting	No	No
Switch to Resistance Heat Based on Indoor Temperature	Determined by Remote Thermostat	N/A
Switch to Resistance Heat Based on Outdoor Temperature	Yes	N/A
Reverse Cycle Defrost	Yes	N/A
Simultaneous Partial Resistance Heat with Heat Pump	Yes	N/A
Resistance Heat Lockout	Yes	N/A
“Smart Fan” Fan Cycle	Fan ON/AUTO Set On Remote Thermostat	Fan On/Auto Set On Remote Thermostat
Central Desk Control	Yes	Yes

**NOTE:** The Class 2 Mode setting (Mode 6) must be set to ON “” for the unit to operate with a Class 2 Remote Wall Thermostat. (See the installation instructions supplied with the remote thermostat and mode instructions on page 10.)

## Makeup Air Models (not on all units)

The make-up air ventilation system is designed to provide continuous outdoor air through the vent door and into the room. In addition to providing fresh air, it dehumidifies incoming air when it is above 55% relative humidity.

### \*DAM Models

The make-up air ventilation system is operated by a switch located on the front of the electrical control cover under the Zoneline room front. The system is turned on and off by depressing the on (I) or off (O) button as shown in the illustration.

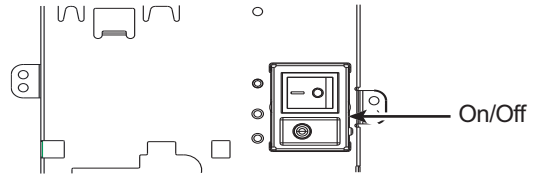

Should the Zoneline need to be operated as a PTAC or PTHP only, the following steps should be followed:

1. Order service PN# WP76X21320.
2. Unplug the Zoneline.
3. Remove the room front.
4. Turn off the ventilation system by depressing the on/off button so that off (O) is selected (see above illustration for location).
5. Pull the Zoneline from the wall sleeve and install service PN# WP76X21320 as shown in the illustration.
6. Push the Zoneline back into the wall sleeve and restore power to the unit.

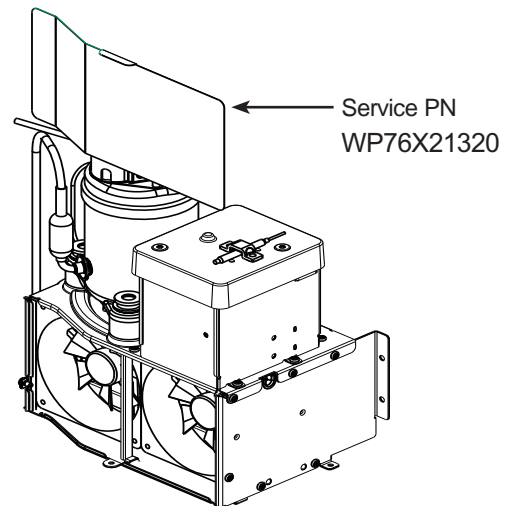

### \*DBM and \*EBM Models

The makeup air ventilation system is operated through the Zoneline's auxiliary menu (see Auxiliary Controls section). To turn the system on or off, follow the directions below:

1. Remove the room front.
2. Press the mode control button and turn off the unit
3. Press the red AUX SET button ("AU" appears on the display).
4. To turn off the MUAM press the mode control button until "0" appears in the first digit.
5. Press the minus on the control panel until "00" is displayed to turn off the makeup air module.
6. The system is preset from the factory at 35 cfm. To change that value press the + or - for the fan speed desired: 1=25cfm, 2=30cfm, 3=35cfm, 4=40cfm, 5=45 cfm and 6=50cfm.
7. Depress the red Aux button again to return to normal operation.

5. Pull the Zoneline from the wall sleeve and install service PN# WP76X21320 as shown in the illustration.
6. Push the Zoneline back into the wall sleeve and restore power to the unit.

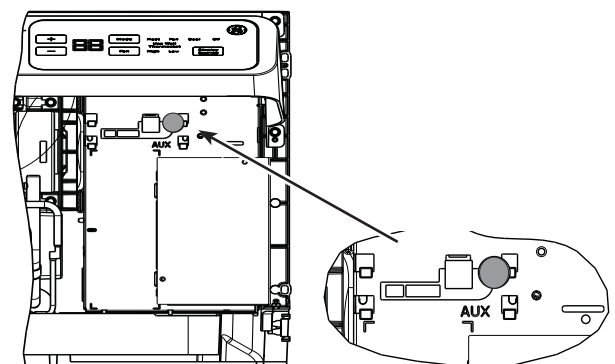

Should the Zoneline need to be operated as a PTAC or PTHP only, the following steps should be followed:

1. Order service PN# WP76X21320.
2. Unplug the Zoneline.
3. Remove the room front.
4. Turn off the makeup air module as instructed above.

**NOTE:** Digital makeup air units will perform a system check upon power up, power cycle and once every 7 days if the unit is in occupancy mode. The system check lasts approximately 45 seconds. During this time the fans will speed up, slow down, and then go to the set point.

# Care and Cleaning

## Room Cover and Case

Turn the Zonline off and disconnect the power supply.

To clean, use water and a mild detergent. Do not use bleach or abrasives. Some commercial cleaners may damage the plastic parts.

## Outdoor Coils

The coils on the outdoor side of the Zonline should be checked regularly. If they are clogged with dirt or soot, they should be cleaned by either low or no pressure cleaning methods. Ensure that electrical area/devices are protected during cleaning. You will need to remove the unit from the wall sleeve to inspect the coils. The dirt buildup occurs on the fan side of the outdoor coil.

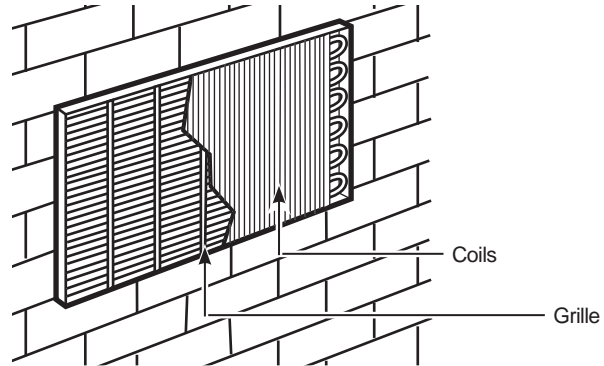

Clean the outside coils regularly.

## Base Pan

In some installations, dirt or other debris may be blown into the unit from the outside and settle in the base pan (the bottom of the unit).

In some areas of the United States, a naturally occurring “gel-like” or “slime-like” substance may be seen in the base pan.

Check it periodically and clean, if necessary.

On 4500 Series models, do not remove the rubber drain plug from the base pan. If removed, excess water may drain to the outside.

## Ventilation Filter

If the vent door is open, clean the vent filter twice a year or as required. Access requires the removal of the unit from the wall sleeve.

Turn the Zonline off and unplug before removing and cleaning.

### To clean the vent filter:

**IMPORTANT:** This filter is not removable. Trying to remove this filter will damage the unit.

- Use a vacuum to remove debris from the filter.
- Use a damp rag to wipe down the filter and surrounding area after vacuuming.

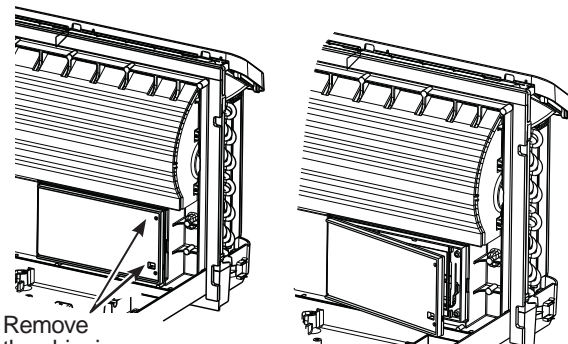

Remove the shipping screws (if operation is desired)



# Care and Cleaning

## Air Filters

To maintain optimum performance, clean the filters at least every 30 days.



*Dirty filter—  
Needs cleaning*

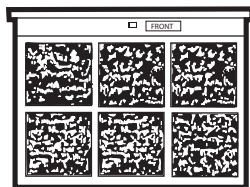

*Clogged filter—  
Greatly reduces cooling,  
heating and airflow.*

### Turn the Zoneline off before cleaning.

The most important thing you can do to maintain the Zoneline is to clean the filter at least every 30 days. Clogged filters reduce cooling, heating and air flow.

### Keeping these filters clean will:

- Decrease cost of operation.
- Save energy.
- Prevent clogged heat exchanger coils.
- Reduce the risk of premature component failure.

### To clean the air filters:

- Vacuum off the heavy soil.
- Run water through the filters from the back side.
- Dry thoroughly before replacing.

**NOTE:** The air filters are interchangeable and will fit in either the right or left side.

### To remove the air filters:

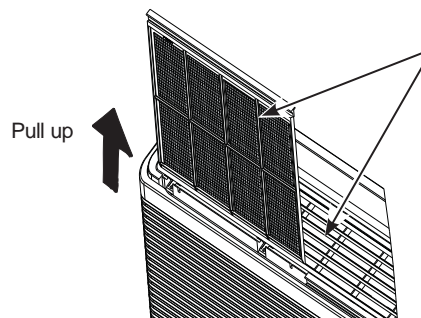

### To replace the air filters:

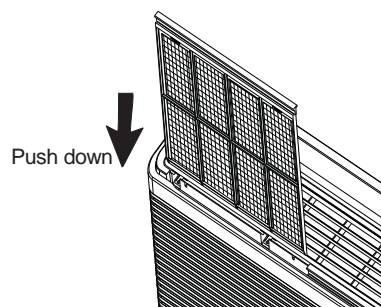

### NOTICE:

Do not operate the Zoneline without the filters in place. If a filter becomes torn or damaged, it should be replaced immediately.

Operating without the filters in place or with damaged filters will allow dirt and dust to reach the indoor coil and reduce the cooling, heating, airflow and efficiency of the unit.

Replacement filters are available from your salesperson, GE Appliances dealer, GE Appliances Service and Parts Center or authorized Customer Care® servicers.



# Installation Instructions

Questions? Call 844-GE4-PTAC (or 844-434-7822 ) or Visit our Website at: [GEAppliances.com](http://GEAppliances.com)

## BEFORE YOU BEGIN

Read these instructions completely and carefully.

- **IMPORTANT** — Save these instructions for local inspector's use.
- **IMPORTANT** — Observe all governing codes and ordinances.
- **Note to Installer** — Be sure to leave these instructions with the owner.
- **Note to Owner** — Keep these instructions for future reference.
- Proper installation is the responsibility of the installer.
- Product failure due to improper installation is not covered under the Warranty.
- You must use all supplied parts and use proper installation procedures as described in these instructions when installing this air conditioner.

## AIR CONDITIONER BREAK-IN PERIOD

**NOTE** — As with any mechanical device with moving parts, this unit will have a wear-in period. **AFTER INSTALLATION**, this unit should be operated for 48 hours to achieve optimum efficiency.

## TOOLS YOU WILL NEED



Phillips screwdriver  
or 5/16" Nut driver

## ZONELINE COMPONENTS

Appearance may vary.

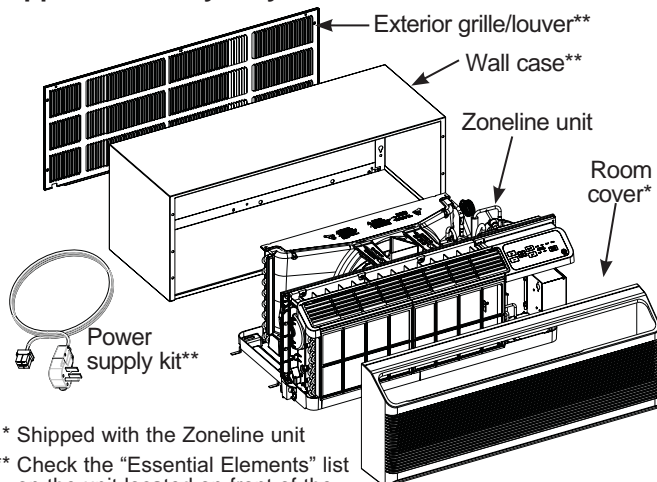

\* Shipped with the Zoneline unit

\*\* Check the "Essential Elements" list on the unit located on front of the base pan

## IMPORTANT ELECTRICAL SAFETY— READ CAREFULLY

### ⚠ CAUTION

- Follow the National Electrical Code (NEC) or local codes and ordinances.
- For personal safety, this Zoneline must be properly grounded.
- Protective devices (fuses or circuit breakers) acceptable for Zoneline installations are specified on the nameplate of each unit.
- Do not use an extension cord with this unit.
- Aluminum building wiring may present special problems—consult a qualified electrician.
- When the unit is in the OFF position, there is still voltage to the electrical controls.
- Disconnect the power to the unit before servicing by:
  - 1 Removing the power cord (if it has one) from the wall receptacle. OR
  - 2 Removing the branch circuit fuses or turning the circuit breakers off at the panel.

### ⚠ ATTENTION

- Suivez le Code national de l'électricité (CNE) ou vos ordonnances et codes locaux.
- Pour votre sécurité personnelle, ce Zoneline doit être bien mis à la terre.
- Les appareils protecteurs (fusibles ou disjoncteurs) acceptables pour installer votre Zoneline sont indiqués sur la plaque signalétique de chaque appareil.
- N'utilisez jamais de rallonge électrique avec cet appareil.
- Les fils de bâtiment en aluminium peuvent poser des problèmes particuliers—consultez un électricien qualifié.
- Quand votre appareil est en position OFF (arrêt), il reste de la tension dans les commandes électriques.
- Débranchez le courant de votre appareil avant de l'entretenir ou de le réparer en:
  1. Enlevant le cordon d'alimentation (le cas échéant) de la prise murale. OU
  2. Enlevant les fusibles du circuit de dérivation ou en débranchant les disjoncteurs de dérivation au panneau.

### ⚠ PRECAUCIÓN

- Siga las instrucciones del National Electrical Code (Código de Electricidad Nacional) (NEC) o los códigos u ordenanzas locales.
- Para su seguridad personal, el acondicionador de aire Zoneline debe tener una adecuada conexión a tierra.
- Los dispositivos de protección (fusibles o disyuntores) adecuados para las instalaciones de Zoneline se encuentran especificados en la placa de cada unidad.
- No utilice un cable de extensión con esta unidad.
- El cableado de aluminio puede presentar problemas especiales: consulte a un electricista calificado.
- Cuando la unidad se encuentra en la posición OFF (apagado), todavía hay voltaje en los controles eléctricos.
- Antes de realizar reparaciones en la unidad, desconecte el suministro de energía de la siguiente manera:
  - 1 Retire el cable eléctrico (si posee uno) del receptáculo de la pared. O
  - 2 Retire los fusibles de la sección o apague el disyuntor desde el panel.

# Installation Instructions

## REPLACING AN EXISTING UNIT

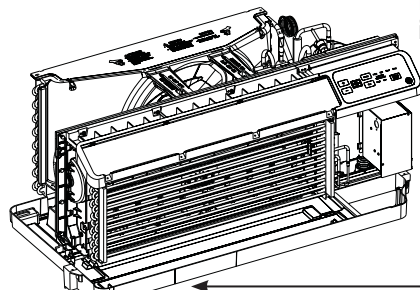

Check the "Essential Elements" label for important information.

### Use the correct wall case

This unit is designed to be installed in a GE Appliances plastic or insulated metal wall case. This minimizes condensation from forming on the room side of the case.

**NOTE:** There are several extra holes in the unit side flanges for installation in wall cases other than GE Appliances. To avoid damaging the flange insulation, the installer should use an awl or other sharp tool to puncture the insulation in the appropriate holes before installing the attachment screws.

### Use the correct outdoor grille

You should use the outdoor grilles shown on the "Essential Elements" label on the base pan.

- If an existing grille is not replaced, capacity and efficiency will be reduced and the unit may fail to operate properly or fail prematurely. A deflector kit, RAK40, may be used with grilles that were not designed for your new GE Appliances Zonelines. The RAK40 contains air deflectors and gaskets that mount to the unit to direct the hot exhaust air away from the air intake to allow the unit to function properly. **The grille must have a 65% minimum free area (as calculated by ASHRAE).** See the Architects and Engineers Data Manual for more detailed information.
- Any vertical deflectors in a non GE Appliances existing rear grille should be removed to decrease condenser air recirculation that can cause the unit to "short-cycle" and lead to premature component failure.

### Use the correct power cord

Local codes may require the use of arc fault or leakage current detection devices on 230/208-volt installations.

### Replacing a ducted unit

#### New ducted installation:

If this unit is to be installed in a new ducted application using a duct adapter kit, the kit must be installed before the unit is placed in the wall case. The installation instructions are packed with the kit.

#### Duct kits available:

- RAK6053
- RAK601B/602B

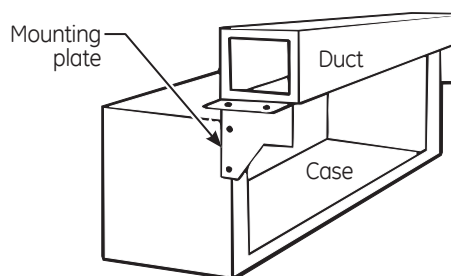

#### Existing ducted installation:

Replacement of an existing ducted unit may require different components. Request this information from your sales representative. **Duct seals on existing unit need to be removed and added to the new unit.**

- **Replacing 230/208 volt units:**  
See page 19.
- **Replacing 265 volt units:**  
See page 20.

**When using a duct kit, you must always turn Mode 7 to ON "  " See Mode instructions on page 11.**



Duct Mode  
Shown ON

## 230/208 VOLT ELECTRICAL CONNECTION OPTIONS

### POWER CORD CONNECTION

Depending on application, a power supply kit with LCDI must be used to supply power to the Zoneline unit. The appropriate kit is determined by the voltage, the means of electrical connection and the amperage of the branch circuit.

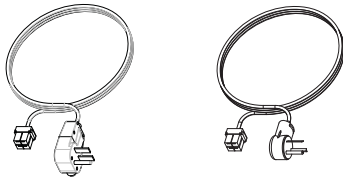

Power supply kit  
(Appearance may vary)

Connections of 208 or 230-volt circuits may be with a power supply kit or a junction box kit.

All wiring, including installation of the receptacle, must be in accordance with the NEC and local codes, ordinances and regulations. Codes require the use of an arc fault or leakage current detection device on the power cord except direct connect. Be sure to select the correct cord for your installation.



**Tandem**  
15 Amp



**Perpendicular**  
20 Amp



**Large Tandem**  
30 Amp

230/208 volt receptacle configuration

Branch Circuit and Unit Amperage Rating	Proper GE Appliances Power Cord with LCDI Device
15	RAK315P
20	RAK320P
30	RAK330P*

Power cords may include an arc fault interruption or a leakage current detection interruption device. A test and reset button is provided on the plug case or the inline case. The device should be tested on a periodic basis by first pressing the TEST button and then the RESET button. If the TEST button does not trip or if the RESET button will not stay engaged, discontinue use of the Zoneline and contact a qualified service technician.

### ELECTRICAL SUBBASE CONNECTION

230/208-volt models may be installed using one of the following electrical subbases:

Branch Circuit and Unit Amperage Rating	Proper GE Appliances Subbase Kit
15	RAK204D15PA
20	RAK204D20PA
30	RAK204D30PA

Electrical subbases provide an enclosure for direct connection or enclosed receptacles. The subbase kit includes the power cord.

The instructions provided with the selected subbase kit must be carefully followed. It is the responsibility of the installer to ensure the connection of components is done in accordance with these instructions and all electrical codes.

If using a sub-base connection, the RAK4002C Junction Box is also necessary for a complete installation.

### DIRECT CONNECTION

Order the following Kit for 230/208-volt direct connection as required:

Branch Circuit and Unit Amperage Rating	Power Supply Kit
15	RAK315D
20	RAK320D
30	RAK330D

Review installation instructions provided with power cord or direct connect kits for detailed assembly instructions.

If using a sub-base connection, the RAK4002C Junction Box is also necessary for a complete installation.

# Installation Instructions

## 265 VOLT ELECTRICAL CONNECTION OPTIONS

### WARNING

Connection of this 265 V AC product to a branch circuit **MUST** be done by direct connection in accordance with the National Electrical Code. Plugging this unit into a building-mounted exposed receptacle is not permitted by code.

These models must be installed using the appropriate GE Appliances power supply kit for the branch circuit amperage and the electrical resistance heater wattage desired. Use the POWER CONNECTION CHART on page 21 to determine the correct kit required. One of the following installation methods must be used:

### AVERTISSEMENT

Vous DEVEZ brancher ce produit alimenté par courant alternatif de 265 volts au circuit de dérivation par branchement direct conformément au Code national d'électricité. Le Code n'autorise pas le branchement d'un appareil à une prise exposée montée sur le bâtiment.

Vous devez installer ces modèles à l'aide de la bonne trousse d'alimentation électrique GE Appliances pour l'ampérage du circuit de dérivation et la puissance du chauffage à résistance électrique désirée. Utilisez le Tableau de contact électrique, page 21, pour déterminer la bonne trousse requise. Vous devez utiliser l'une des méthodes suivantes d'installation.

### ADVERTENCIA

La conexión de este producto de 265 voltios de CA a un circuito derivado DEBE realizarse mediante una conexión directa de acuerdo a las indicaciones del NEC. El código no permite enchufar esta unidad a una caja externa.

Estos modelos deben instalarse utilizando el kit de GE Appliances de suministro de energía adecuado para el amperaje de circuito derivado y el vatiaje deseado para el calefactor de resistencia eléctrica. Utilice la TABLA DE CONEXIONES ELÉCTRICAS en la página 21 para determinar cuál es el kit necesario. Debe utilizarse uno de los siguientes métodos de instalación.

### A. FOR SUBBASE INSTALLATION

Electrical subbase kits are available to provide a flexible enclosure for direct connection.

Branch Circuit and Unit Amperage Rating	Proper GE Appliances Subbase Kit	Power Supply Kit
15	RAK204E15	RAK515P
20	RAK204E20	RAK520P
30	RAK204E30	RAK530P

The instructions provided with the selected subbase kit must be carefully followed. It is the responsibility of the installer to ensure the connection of components is done in accordance with these instructions and all electrical codes.

### B. FOR DIRECT CONNECT INSTALLATION

If an electrical subbase is not used, direct connection to branch circuit wiring inside the provided junction box must be done in accordance with the following steps.

Order the following Kit for 265-volt direct connection as required:

Branch Circuit and Unit Amperage Rating	Power Supply Kit
15	RAK515D
20	RAK520D
30	RAK530D

Review installation instructions provided with power cord or direct connect kits for detailed assembly instructions.

# Installation Instructions

## POWER CONNECTION CHART

### Power Cord Connections

230/208 Volt Power Supply Kits with Current Leakage Detection Device (1)	Wall Plug Configuration	Circuit Protective Device	Heater Wattage @ 230/208 Volts
RAK315P/SP RAK320P/SP RAK330P/SP	Tandem Perpendicular Large Tandem	15-Amp Time-Delay Fuse or Breaker 20-Amp Time-Delay Fuse or Breaker 30-Amp Time-Delay Fuse or Breaker	2.40/1.96 KW 3.40/2.78 KW 4.80/3.93 KW (High Fan) 3.80/3.11 KW (Low Fan)

### Direct Connections

230/208 Volt Power Supply Kits (2)	Circuit Protective Device	Heater Wattage @ 230/208 Volts
RAK315D RAK320D RAK330D	15-Amp Time-Delay Fuse or Breaker 20-Amp Time-Delay Fuse or Breaker 30-Amp Time-Delay Fuse or Breaker	2.40/1.96 KW 3.40/2.78 KW 4.80/3.93 KW (High Fan) 3.80/3.11 KW (Low Fan)

265 Volt Power Supply Kits	Circuit Protective Device	Heater Wattage @ 265 Volts
RAK515D RAK520D RAK530D	15-Amp Time-Delay Fuse or Breaker 20-Amp Time-Delay Fuse or Breaker 30-Amp Time-Delay Fuse or Breaker	2.40 KW 3.40 KW 4.80 KW (High Fan) 3.8 KW (Low Fan)

- (1) A junction box is included with SP kits.  
 (2) A junction box is included with these kits.



# Installation Instructions

## INSTALLING THE ZONELINE

### 1. INSTALL THE WALL CASE AND EXTERIOR GRILLE

The RAB71A/B series or RAB77A4/77B wall case must be properly installed per instructions packed with the case.

- Remove the corrugated stiffener and the outdoor protective panel. Use the slit in the outdoor panel as a hand hold and push out.

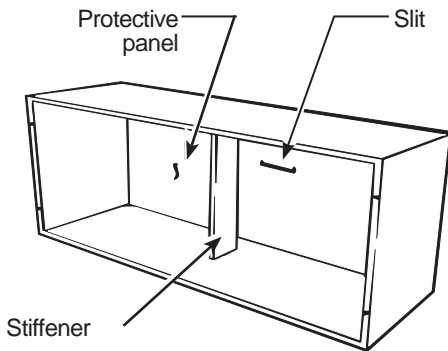

- Install the exterior grille from the room side following instructions packed with the grille.

**NOTE:** For installation with a subbase or duct adapter, see the instructions packed with those kits.

### 2. PREPARE THE UNIT

- Carefully remove the foam shipping blocks from the room front, compressor and outdoor fan. There may be multiple blocks and pieces of shipping tape that need to be removed.

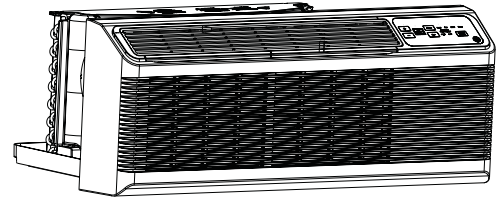

- Remove the room cover by pulling it out at the bottom to release it (1); then lift it up to clear the rail along the unit top (2).

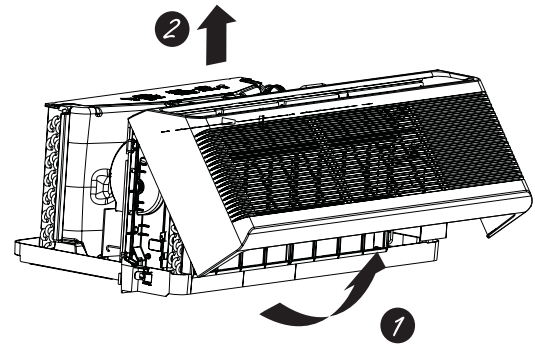

- If vent door is to be operational, remove shipping screws from the front side of the vent door, if present.

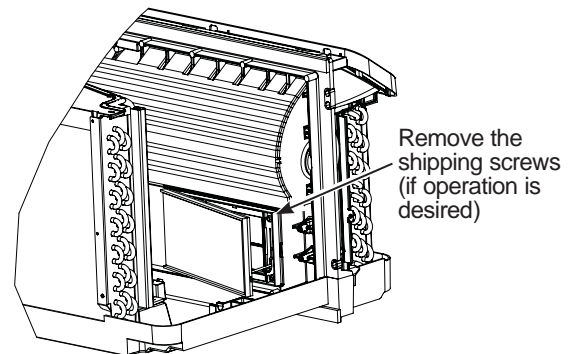

## INSTALLING THE ZONELINE (cont.)

### 3. INSTALL THE UNIT INTO THE WALL CASE

Slide the unit into the wall case and secure with four screws through the unit flange holes.

The four screws will be located in a sealed bag that sits under the control panel, sitting in the pocket in the base pan.

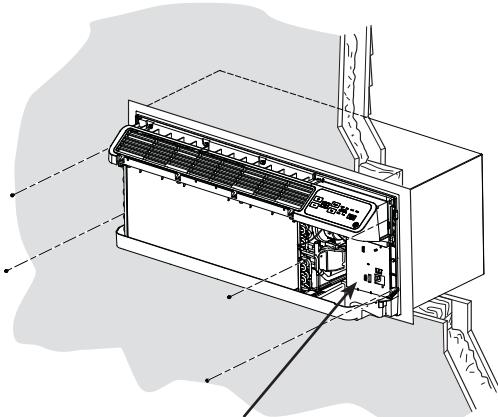

The four wall case screws will be taped to the pocket in front of the control box.

**NOTE:** There are several extra holes in the unit side flanges for installation in wall cases other than GE Appliances. To avoid damaging the flange insulation, the installer should use an awl or other sharp tool to puncture the insulation in the appropriate holes before installing the attachment screws.

### 5. REPLACE THE ROOM FRONT

Reinstall the room cover by aligning and placing the top rail of the room cover over the chassis (1), then pushing it in at the bottom (2).

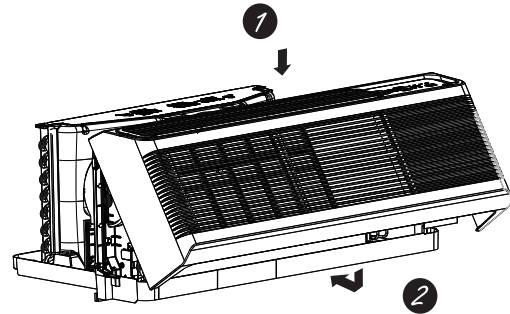

### 4. CONNECT POWER CORD OR DIRECT CONNECT KIT

Review installation instructions provided with power cord or direct connect kits for detailed assembly instructions.

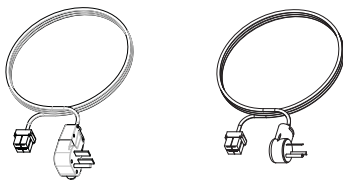

Power supply kit  
(Appearance may vary)

# Installation Instructions

## OPTIONAL—DRAIN KIT INSTALLATION

Dry Air 25 Series models are designed to improve dehumidification by 25%. Since more moisture will be removed from the air, there is a greater possibility that water will drip from the wall case than with a standard unit. To prevent this water from dripping onto external building walls, we recommend the use of RAD10 Drain Kit.

### External Drain

See the Installation Instructions in the RAD10 kit.

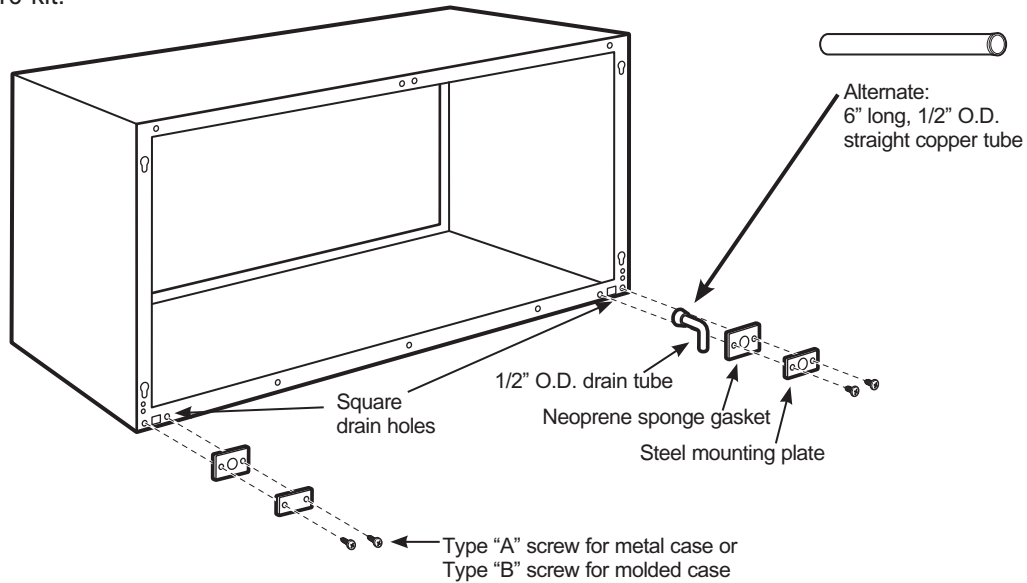

### Internal Drain

See the Installation Instructions in the RAD10 kit.

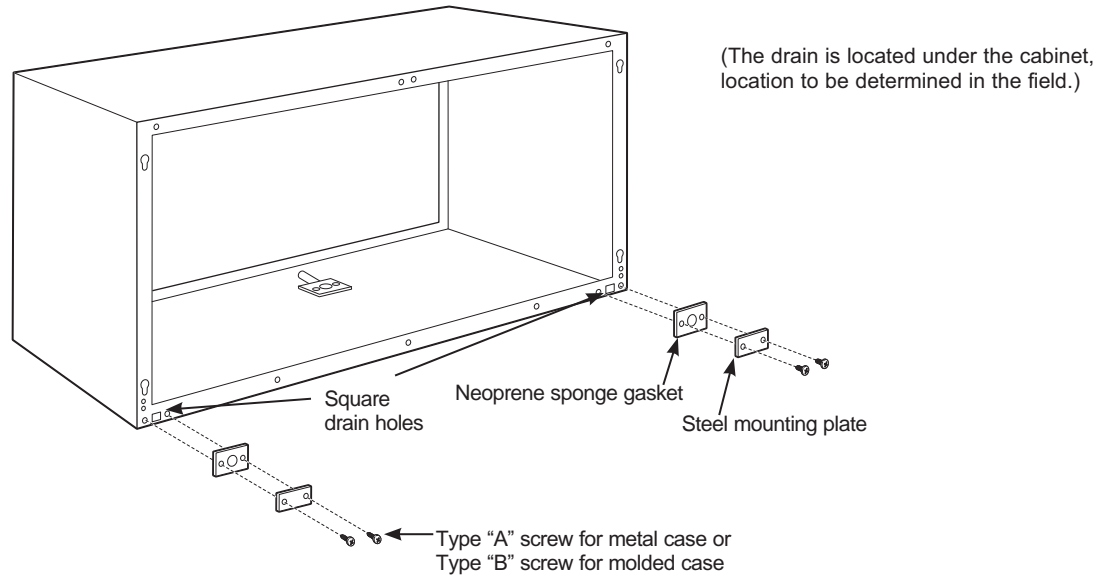



# Troubleshooting Tips... Before you call for service

Save time and money! Review the charts on the following pages first and you may not need to call for service.

Problem	Possible Cause	What To Do
<b>Zoneline does not start.</b>	<b>The unit is unplugged.</b>	Make sure the Zoneline plug is pushed completely into the outlet.
	<b>The power cord is not firmly attached.</b>	Remove the room cover and make sure that the black connector on the end of the power cord is firmly engaged.
	<b>The fuse is blown/circuit breaker is tripped.</b>	Check the house fuse/circuit breaker box and replace the fuse or reset the breaker.
	<b>The unit is waiting for the compressor overload protector to reset.</b>	This is normal. The Zoneline will start again after it resets.
	<b>Power Failure.</b>	If power failure occurs, set the mode control to <b>OFF</b> . When power is restored, set the mode control to the desired setting.  There is a protective time delay (up to 3 minutes) to prevent tripping of the compressor overload. For this reason, the unit may not start normal heating or cooling for 3 minutes after it is turned back on.
	<b>The power cord current interrupter device is tripped.</b>	Press the RESET button located on the power cord plug or the box near the plug.  If the RESET button will not stay engaged, discontinue use of the Zoneline and contract a qualified service technician.
<b>Zoneline does not cool or heat as it should.</b>	<b>Indoor airflow is restricted.</b>	Make sure there are not curtains, blinds or furniture blocking the front of the Zoneline.
	<b>Outdoor airflow is restricted or recirculated.</b>	Make sure the rear grille is not restricted. This can cause the unit to cycle off due to the compressor overload protector.  Outdoor grille must have a minimum of 65% free area. Non-GE Appliances grills may be too restrictive for proper performance. Consult your salesperson for assistance.
	<b>The temp control may not be set properly.</b>	Turn the control to the lower or higher setting. <b>NOTE:</b> The temperature limiter may be limiting the temperature range.
	<b>The air filter is dirty.</b>	Change the filter at least every 30 days. See the Care and Cleaning section
	<b>The room may have been hot or cold.</b>	When the Zoneline is first turned on you need to allow time for the room to cool down or warm up.
	<b>Outdoor air is entering the room.</b>	Set the vent control to the closed position. <b>NOTE:</b> Units equipped with makeup ventilation will continuously allow some outdoor air into the room.
<b>Burning odor at the start of heating operation.</b>	<b>Dust on the surface of the heating elements.</b>	This can cause a "burning" odor at the beginning of the heating operation. This should quickly fade.

## Troubleshooting Tips... Before you call for service

Save time and money! Review the charts on the following pages first and you may not need to call for service.

Problem	Possible Cause	What To Do
The air is not always cool or hot during operation.	The heat pump is not producing hot air.	This is normal. The heat pump will produce warm air but not as hot as air produced when the higher-cost electric heat is used.
	The Smart Fan Auxiliary control may be set to continuous fan.	This causes the fan to blow room temperature air even when the compressor or heater cycles off. The continuous air movement provides better overall temperature control in the cool mode. See Smart Fan-Cooling/Heating section on page 9.
The air does not feel warm enough during heating operation	The heat pump alone produces air that feels cooler than desired.	Use the Electric Heat Option. This turns off the heat pump and warms with electric heat only. <b>NOTE:</b> Use of this option will result in increased energy consumption.
The unit is not blowing out air	The Smart Fan Auxiliary Controls may be set to cycle.	See Smart Fan - Cooling/Heating section on page 9.
The electric heating and fan features do not work	The power cord is not firmly attached.	Remove the room cover and make sure that the black connector on the end of the power cord is firmly engaged.
Temperature display flashes	The compressor may have failed.	Set the operation control to OFF and then restart the unit. If the flashing light reappears within 30 minutes, call for service.
The unit does not function after installing Remote Wall Thermostat	Aux Mode 6 not set properly.	Verify wiring from Remote Wall Thermostat is correct to unit thermostat connector.
	Unit thermostat connections are incorrect.	Check Aux Mode 6 to be sure switch on "on" for Remote Thermostat, see page 11.
	Transformer resets or opens with short.	Wait 5 minutes to see if power resets.
Heat pump operates with electric heat only during heating.	Aux Mode 6 not set properly.	Check Aux Mode 6 is set for the appropriate remote wall thermostat, either "C" for "cool/heat" or "H" for "Auto Change Over", see page 10.
	Aux Mode 8 not set properly.	Check Aux Mode 8 to be sure switch is "off" for heat pump operation, see page 11.

# Things that are normal

---

## *Normal Operating Sounds*



You may hear a pinging noise caused by water being picked up and thrown against the condenser on rainy days or when the humidity is high. This design feature helps remove moisture and improve efficiency.

---

**“CLICK”**

You may hear relays click when the controls cycle on and off or are adjusted to change the room temperature.

---



Water will collect in the base pan during high humidity or on rainy days. The water may overflow and drip from the outdoor side of the unit.

---



The indoor fan runs continuously when the unit is operating in the cooling mode, unless the Smart Fan Auxiliary Control is set to cycle. This will cause the fan to cycle on and off with the compressor. You may also hear a fan noise stop and start.

There are times when the fan on the unit will run even when the unit is not heating or cooling. If the system is set up to be in continuous fan the indoor fan will run regardless if the unit may be cooling or heating. Other times the fan will run longer than the heating/cooling cycle or kick on occasionally. This is normal and is done to improve room comfort and balance.

If the unit is equipped with a make-up air ventilation system, fans will run continuously.

Digital makeup air unit will perform a system check upon power up, power cycle, and once every 7 days if the unit is in occupancy mode. The system check lasts approximately 45 seconds. During this time the fans will speed up, slow down and then go to the set point.

---

**3-Minute Delay**



You may notice a few minutes delay in starting if you try to restart the Zoneline too soon after turning it off or if you adjust the thermostat right after the compressor has shut off. This is due to a built-in restart protector for the compressor that causes a 3-minute delay.

---

**SILENCE**

During the defrost cycle, both indoor and outdoor fans stop and the compressor will operate in the cooling mode to remove frost from the outdoor coil. After defrost, the unit will restart in electric heat to quickly warm the room to the desired comfort level.

---

**COMPRESSOR PROTECTION**

To protect the compressor and prevent short cycling, the unit is designed to run for a minimum of 3 minutes after the compressor starts at any thermostat setting.

---



# Product Registration

Follow these three steps to protect your new appliance investment:

**1** Complete and mail your Consumer Production Registration today. Have the peace of mind of knowing we can contact you in the unlikely event of a safety modification.

**2** After mailing the registration below, store this document in a safe place. It contains information you will need should you require service. Our service number is 844-GE4-PTAC (or 844-434-7822 ).

**3** Read your Owner's Manual carefully. It will help you operate your new appliance properly.

✂ cut here

## CONSUMER PRODUCT OWNERSHIP REGISTRATION

Three ways to register your appliance:



**SCAN**  
this code with your smart-phone app

**GO ONLINE**  
[geappliances.com/register](http://geappliances.com/register)

**COMPLETE & MAIL**  
this registration card

Product:  
Model:  
Serial:

Mr.  Mrs.  Ms.

First Name  Last Name

Street Address  Apt.#

Email Address   
We'll use your email address to send you information about your product, as well as discounts and other offers from GE Appliances

City  State  ZIP Code

Month  Day  Year  Phone Number  (  )

Date appliance was installed or placed in use

GE Appliances takes your privacy seriously. All information you provide shall be held in strict accordance with the GE Appliances Privacy Policy. Read the full policy at [www.geappliances.com/privacy/privacy\\_policy.htm](http://www.geappliances.com/privacy/privacy_policy.htm).

[geappliances.com/register](http://geappliances.com/register)

Revised 6/15  
245D1499P001

✂ cut here

## FOR CANADIAN CONSUMERS / POUR LES CONSOMMATEURS CANADIENS

MODEL/MODÈLE		SERIAL/SÉRIE		P.O. BOX/C.P. 1780 MISSISSAUGA, ONT. L4V 4G1	
				INSTALLATION DATE Y/A M DATE D'INSTALLATION	
PLEASE COMPLETE AND RETURN THIS CARD IMMEDIATELY TO ENABLE US TO CONTACT YOU IN THE REMOTE EVENT A SAFETY NOTIFICATION IS ISSUED FOR THIS PRODUCT.			VEUILLEZ REMPLIR ET RETOURNER LA PRÉSENTE FICHE SANS TARDER AFIN DE NOUS PERMETTRE DE COMMUNIQUER AVEC VOUS SI JAMAIS UN AVIS DE SÉCURITÉ CONCERNANT CE PRODUIT ÉTAIT ÉMIS.		
CHECK ONE COCHEZ	MR. <input type="checkbox"/> M <input type="checkbox"/> MISS <input type="checkbox"/> Mlle	MRS. <input type="checkbox"/> MME <input type="checkbox"/> MMS	FIRST NAME/PRÉNOM	LAST NAME/NOM	
STREET NO. N° RUE		STREET NAME/RUE		APT.NO./APP./RR#	
CITY/VILLE		PROVINCE	POSTAL CODE/POSTAL		
AREA CODE IND. REG.	TELEPHONE	NAME OF SELLING DEALER/NOM DU MARCHAND			

Canada consumers, visit [geappliances.ca/register/index.jsp](http://geappliances.ca/register/index.jsp)

CORRESPONDENCE  
CORRESPONDANCE

FRENCH  
FRANÇAIS

ENGLISH  
ANGLAIS

245D1499P002  
Revised 06/14

# Product Registration

---

Please place in envelope and mail to:

PRODUCT REGISTRATION DEPARTMENT  
PO BOX 34980  
LOUISVILLE KY 40232-4980

Please place in envelope and mail to:  
Veuillez mettre dans une enveloppe et envoyez à :

OWNERSHIP REGISTRATION  
PO BOX 1780  
MISSISSAUGA, ONTARIO  
L4Y 4G1

# GE Appliances Zonline Warranty

All warranty service provided by our Factory Service Centers or an authorized Customer Care® technician. To schedule service, on-line, visit us at [GEAppliances.com](http://GEAppliances.com), or call 844-GE4-PTAC (or 844-434-7822 ). For service in Canada, contact Gordon Williams Corp. at 1.888.209.0999. Please have serial number and model number available when calling for service.

For The Period Of:	GE Will Replace:
<b>One Year</b> <i>From the date of the original purchase</i>	<b>Any part</b> of the air conditioner which fails due to a defect in materials or workmanship. During this <b>limited one-year warranty</b> , GE will provide, <b>free of charge</b> , all labor and related service cost to replace the defective part.
<b>Five Year</b> <i>From the date of the original purchase</i>	<b>Sealed Refrigerating System, if any part of the sealed refrigerating system</b> (the compressor, condenser, evaporator and all connecting tubing including the make up air system) should fail due to a defect in materials or workmanship. During this <b>limited five-year warranty</b> , GE will provide, <b>free of charge</b> , all labor and related service cost to replace the defective part.
<b>Second through Fifth Year</b> <i>From the date of the original purchase</i>	<b>Fan Motors, Switches, Thermostat, Heater, Heater Protectors, Compressor Overload, Solenoids, Circuit Boards, Auxiliary Controls, Thermistors, Freeze Sentinel, Frost Controls, ICR Pump, Capacitors, Varistors and Indoor Blower Bearings</b> , if any of these parts should fail due to a defect in materials or workmanship. During this <b>additional four-year limited warranty</b> , the customer will be responsible for any labor and related service costs.

## What GE Will Not Cover:

- Service trips to your site to teach you how to use the product.
- Improper installation, delivery or maintenance.  
If you have an installation problem, or if the air conditioner is of improper cooling capacity for the intended use, contact your dealer or installer. You are responsible for providing adequate electrical connecting facilities.
- In commercial locations, labor necessary to move the unit to a location where it is accessible for service by an individual technician.
- Failure or damage resulting from corrosion due to installation in an environment containing corrosive chemicals.
- Replacement of fuses or resetting of circuit breakers.
- Failure of the product resulting from modifications to the product or due to unreasonable use, including failure to provide reasonable and necessary maintenance.
- Failure or damage resulting from corrosion due to installation in a coastal environment, except for models treated with special factory-applied anti-corrosion protection as designated in the model number.
- Damage to product caused by improper power supply voltage, accident, fire, floods or acts of God.
- Incidental or consequential damage to personal property caused by possible defects with this air conditioner.
- Damage caused after delivery.
- Product not accessible to provide required service.

**EXCLUSION OF IMPLIED WARRANTIES**—Your sole and exclusive remedy is product repair as provided in this Limited Warranty. Any implied warranties, including the implied warranties of merchantability or fitness for a particular purpose, are limited to one year or the shortest period allowed by law.

This warranty is extended to the original purchaser and any succeeding owner for products purchased for use within the USA and Canada. If the product is located in an area where service by a GE Appliances Authorized Servicer is not available, you may be responsible for a trip charge or you may be required to bring the product to an Authorized GE Appliances Service location for service. In Alaska, the warranty excludes the cost of shipping or service calls to your site.

Some states or provinces do not allow the exclusion or limitation of incidental or consequential damages. This warranty gives you specific legal rights, and you may also have other rights which vary from state to state or province to province. To know what your legal rights are, consult your local, state or provincial consumer affairs office or your state's Attorney General.

**Warrantor: GE Appliances**

Staple your receipt here. Proof of the original purchase date is needed to obtain service under the warranty.

# Consumer Support

---

## GE Appliances Website

Have a question or need assistance with your appliance? Try the GE Appliances Website 24 hours a day, any day of the year! You can also shop for more great GE Appliances products and take advantage of all our on-line support services designed for your convenience. In the US: [GEAppliances.com](http://GEAppliances.com)

---

## Register Your Appliance

Register your new appliance on-line at your convenience! Timely product registration will allow for enhanced communication and prompt service under the terms of your warranty, should the need arise. You may also mail in the pre-printed registration card included in the packing material. In the US: [GEAppliances.com/register](http://GEAppliances.com/register)

---

## Schedule Service

Expert GE Appliances repair service is only one step away from your door. Get on-line and schedule your service at your convenience any day of the year. In the US: [GEAppliances.com/ge/service-and-support/service.htm](http://GEAppliances.com/ge/service-and-support/service.htm) or call 800.432.2737 during normal business hours.

---

## Extended Warranties

Purchase a GE Appliances extended warranty and learn about special discounts that are available while your warranty is still in effect. You can purchase it on-line anytime. GE Appliances Services will still be there after your warranty expires. In the US: [GEAppliances.com/ge/service-and-support/shop-for-extended-service-plans.htm](http://GEAppliances.com/ge/service-and-support/shop-for-extended-service-plans.htm) or call 800.626.2224 during normal business hours.

---

## Remote Connectivity

For assistance with wireless network connectivity (for models with remote enable), visit our website at [GEAppliances.com/ge/connected-appliances/](http://GEAppliances.com/ge/connected-appliances/) or call 800.220.6899 in the US.

---

## Parts and Accessories

Individuals qualified to service their own appliances can have parts or accessories sent directly to their homes (VISA, MasterCard and Discover cards are accepted). Order on-line today 24 hours every day. In the US: [GEApplianceparts.com](http://GEApplianceparts.com) or by phone at 877.959.8688 during normal business hours.

**Instructions contained in this manual cover procedures to be performed by any user. Other servicing generally should be referred to qualified service personnel. Caution must be exercised, since improper servicing may cause unsafe operation.**

---

## Contact Us

If you are not satisfied with the service you receive from GE Appliances, contact us on our Website with all the details including your phone number, or write to:

In the US: General Manager, Customer Relations | GE Appliances, Appliance Park | Louisville, KY 40225  
[GEAppliances.com/ge/service-and-support/contact.htm](http://GEAppliances.com/ge/service-and-support/contact.htm)