



ROOM AIR CONDITIONERS

SAFETY INFORMATION3

OPERATING INSTRUCTIONS....4

CARE AND CLEANING

Grille and Case6

Air Filter.....6

Outdoor Coils6

Installing Remote Batteries6

INSTALLATION7

TROUBLESHOOTING TIPS.....12

**APPLIANCE
COMMUNICATION**13

WARRANTY.....14

CONSUMER SUPPORT16

**Owner's Manual
and Installation
Instructions**

- AEC10
- AEC12
- AED10

ENGLISH/ESPAÑOL

Write the model and serial numbers here:

Model # _____

Serial # _____

Find these numbers on a label on the side of the air conditioner.

THANK YOU FOR MAKING GE APPLIANCES A PART OF YOUR HOME.

Whether you grew up with GE Appliances, or this is your first, we're happy to have you in the family.

We take pride in the craftsmanship, innovation and design that goes into every GE Appliances product, and we think you will too. Among other things, registration of your appliance ensures that we can deliver important product information and warranty details when you need them.

Register your GE appliance now online. Helpful websites and phone numbers are available in the Consumer Support section of this Owner's Manual. You may also mail in the pre-printed registration card included in the packing material.



GE APPLIANCES

IMPORTANT SAFETY INFORMATION

READ ALL INSTRUCTIONS BEFORE USING THE APPLIANCE

▲ WARNING

For your safety, the information in this manual must be followed to minimize the risk of fire, electric shock or personal injury.

- Use this appliance only for its intended purpose as described in this Owner's Manual.
- This air conditioner must be properly installed in accordance with the Installation Instructions before it is used.
- Never unplug your air conditioner by pulling on the power cord. Always grip plug firmly and pull straight out from the receptacle.
- Replace immediately all electric service cords that have become frayed or otherwise damaged. A damaged power supply cord must be replaced with a new power supply cord obtained from the manufacturer and not repaired. Do not use a cord that shows cracks or abrasion damage along its length or at either the plug or connector end.
- Turn the unit OFF and unplug your air conditioner before cleaning.
- To avoid risk of injury or property damage, the air conditioner should only be serviced by a qualified servicer.
- For your safety...do not store or use combustible materials, gasoline or other flammable vapors or liquids in the vicinity of this or any other appliance.
- All air conditioners contain refrigerants, which under federal law must be removed prior to product disposal. If you are getting rid of an old product with refrigerants, check with the company handling disposal about what to do.
- If the receptacle does not match the plug, the receptacle must be changed out by a qualified electrician.
- These R410A air conditioning systems require contractors and technicians to use tools, equipment and safety standards approved for use with this refrigerant. DO NOT use equipment certified for R22 refrigerant only.

▲ WARNING

USE OF EXTENSION CORDS

RISK OF FIRE. Could cause serious injury or death.

- DO NOT use an extension cord with this Window Air Conditioner.
- DO NOT use surge protectors or multi-outlet adaptors with this Window Air Conditioner.

HOW TO CONNECT ELECTRICITY

Do not, under any circumstances, cut or remove the third (ground) prong from the power cord. For personal safety, this appliance must be properly grounded.

DO NOT use an adapter plug with this appliance.

The power cord of this appliance is equipped with a 3-prong (grounding) plug which mates with a standard 3-prong (grounding) wall outlet to minimize the possibility of electric shock hazard from this appliance.

Power cord includes a current interrupter device. A test and reset button is provided on the plug case. The device should be tested on a periodic basis by first pressing the TEST button and then the RESET button while plugged into the outlet. If the TEST button does not trip or if the RESET button will not stay engaged, discontinue use of the air conditioner and contact a

qualified service technician.

Have the wall outlet and circuit checked by a qualified electrician to make sure the outlet is properly grounded.

Where a 2-prong wall outlet is encountered, it is your personal responsibility and obligation to have it replaced with a properly grounded 3-prong wall outlet.

The air conditioner should always be plugged into its own individual electrical outlet which has a voltage rating that matches the rating plate.

This provides the best performance and also prevents overloading house wiring circuits which could cause a fire hazard from overheated wires.

See the Installation Instructions, Electrical Requirements section for specific electrical connection requirements.

RECYCLING INFORMATION

For appliance recycling information please visit www.geappliances.com/recycling.

READ AND SAVE THESE INSTRUCTIONS

Controls

Features and appearance will vary.

Lights next to the touch pads on the air conditioner control panel indicate the selected settings.

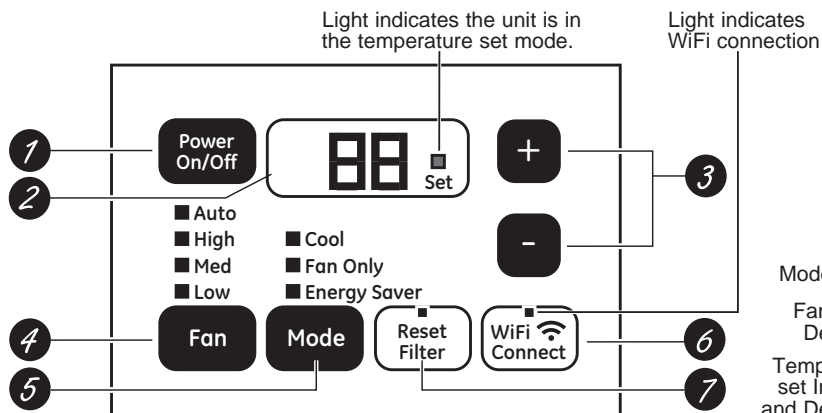

NOTE: The display always shows the room temperature except when setting the set temperature.

Air Conditioner Controls

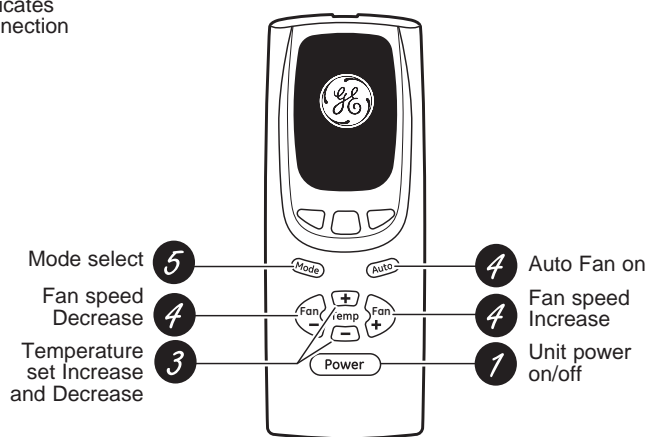

Remote Control

Controls

NOTE: When the bucket is full or removed, the controls cannot be set.

1. Power Pad

Turns air conditioner on and off. When turned on, the display will show the room temperature.

2. Display

Shows the room temperature. Shows the Set temperature while setting the temperature in **Cool** or **Energy Saver** modes. The Set light will turn on while setting.

3. Temp Increase ▲ /Decrease ▼ Pads

Use to set temperature when in **Cool** or **Energy Saver** mode. The Set light will turn on while setting.

4. Fan Speed Pads

Use to set the fan speed to **Low**, **Med**, **High** or **Auto** on the unit. **NOTE:** On the remote control, use the fan speed **Increase + / Decrease -** pads to set the fan speeds to **Low**, **Med** or **High**. Use the **Auto** pad to turn **Auto** fan on.

5. Mode Pad

Use to set the air conditioner to **Cool**, **Energy Saver** or **Fan Only** mode.

6. WiFi Connect

Enables connection of the air conditioner to the home WiFi. Download App for details at www.GEAppliances.com/connect.

7. Reset Filter

LED will turn on when fan has accumulated 250 hours of run time as a reminder to clean filter. Press **Reset Filter** to turn off the LED and reset the accumulated run time.

NOTE: The default temperature reading on the display is degree Fahrenheit (°F). To change the display to degree Celcius (°C), press the Temp Increase ▲ and Temp Decrease ▼ buttons together and hold for 3 seconds. Repeat the process to change back to degree Fahrenheit (°F)

Do Not Operate in Freezing Outdoor Conditions

This cool-only air conditioner was not designed for freezing outdoor conditions. It must not be used in freezing outdoor conditions.

Remote Control

- To ensure proper operation, aim the remote control at the signal receiver on the air conditioner.
- Make sure nothing is between the air conditioner and the remote control that could block the signal.
- The remote control signal has a range of up to 20 feet.
- Make sure batteries are fresh and installed correctly as indicated on the remote control.
- Remote contains a magnet allowing it to attach to metal surfaces.

Controls

Cool Mode

Use the Cool mode at **Low, Med, High** or **Auto Fan Speed** for cooling. Use the **Temperature Increase ▲ / Decrease ▼** pads to set the desired temperature between 64°F and 86°F in 1°F increments.

An electronic thermostat is used to maintain the room temperature. The compressor will cycle on and off to keep the room at the set level of comfort. Set the thermostat at a lower number and the indoor air will become cooler. Set the thermostat at a higher number and the indoor air will become warmer.

NOTE: If the air conditioner is off and is then turned on while set to a Cool setting or if turned from a fan setting to a Cool setting, it may take approximately 3 minutes for the compressor to start and cooling to begin.

Cooling Descriptions

For Normal Cooling—Select the **Cool** mode and **High** or **Med** fan with a middle set temperature.

For Maximum Cooling—Select the **Cool** mode and **High** fan with a lower set temperature.

For Quieter and Nighttime Cooling—Select the **Cool** mode and **Low** fan with a middle set temperature.

Energy Saver Mode

This mode optimizes the cooling power of your air conditioner, thereby saving you energy. Once the set point temperature has been reached, the fan will cycle off to save energy. The fan will cycle back on periodically to insure all cooling capacity in the system is used. This mode is the default mode for the unit. Each time the unit is powered off, it will restart in **Energy Saver mode ON**. The first time the unit is turned on, the settings will be 70° and **Low** fan. You can adjust the fan speed and temperature to your personal comfort.

Energy Saver ON—Helps minimize electricity use. It is normal for the fan to cycle off and then back on in this mode. This on/off cycle can repeat multiple times. Because the fan will cycle off, you may notice a variation in room temperature and humidity.

Energy Saver OFF—When this mode is not engaged, the fan will run continuously, and in Cool mode the compressor will cycle on and off to maintain room temperature.

Fan Only Mode

Use the Fan Only Mode at Low, Med or High fan speed to provide air circulation and filtering without cooling. Since fan-only settings do not provide cooling, a Set temperature cannot be entered. The room temperature will appear in the display.

NOTE: Auto Fan Speed cannot be used when in the **Fan Only Mode**.

Auto Fan Speed

Set to Auto fan speed for the fan speed to automatically set to the speed needed to provide optimum comfort settings with the set temperature.

If the room needs more cooling, the fan speed will automatically increase. If the room needs less cooling, the fan speed will automatically decrease.

NOTE: Auto Fan Speed cannot be used when in the **Fan Only Mode**.

Power Outage Recovery Feature

In the case of a power outage or interruption, the unit will automatically restart in the settings last used after the power is restored.

Air Direction

Use the lever to adjust the air direction left and right only.

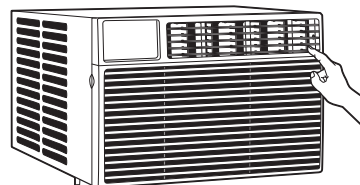

Care and Cleaning

Grille and Case

Turn the air conditioner off and remove the plug from the wall outlet before cleaning.

To clean, use water and a mild detergent. Do not use bleach or abrasives.

Air Filter

The air filter behind the front grille should be checked and cleaned at least every 30 days or more often if necessary.

To remove:

Pull the tab on the right side of the unit until the filter is out.

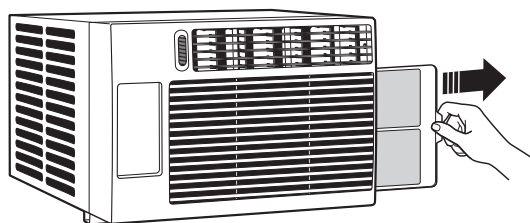

Clean the filter with warm, soapy water. Rinse and let the filter dry before replacing it. Do not clean the filter in a dishwasher.

CAUTION DO NOT operate the air conditioner without a filter because dirt and lint will clog it and reduce performance.

To remove:

Open the inlet grille by pulling downward on the tabs at the top upper corners of the inlet grille until the grille is in a 45° position. Remove the filter.

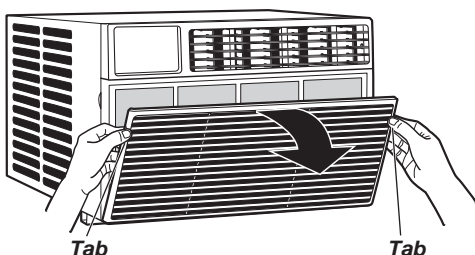

Outdoor Coils

The coils on the outdoor side of the air conditioner should be checked regularly. If they are clogged with dirt or soot, they may be professionally cleaned.

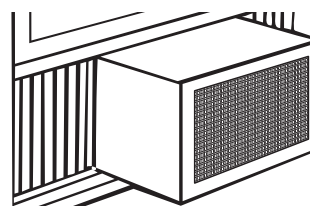

How to Insert the Batteries in the Remote Control

1. Remove the battery cover by sliding it according to the arrow direction.
2. Insert new batteries, making sure that the (+) and (-) of battery are installed correctly.
3. Reattach the cover by sliding it back into position.

NOTES:

- Use 2 "AAA" (1.5 volt) alkaline batteries. Do not use rechargeable batteries.
- Remove the batteries from the remote control if the system is not going to be used for a long time.
- Do not mix old and new batteries. Do not mix alkaline, standard (carbon-zinc) or rechargeable (ni-cad, ni-mh, etc) batteries.

Installation Instructions

Air Conditioner

? Questions? Call GE Appliances at 800.GE.CARES (800.432.2737) or Visit our Website at: GEAppliances.com

BEFORE YOU BEGIN

Read these instructions completely and carefully.

- **IMPORTANT** — Save these instructions for local inspector's use.
- **IMPORTANT** — Observe all governing codes and ordinances.
- **Note to Installer** – Be sure to leave these instructions with the Consumer.
- **Note to Consumer** – Keep these instructions for future reference.
- **Skill level** – Installation of this appliance requires basic mechanical skills.
- **Completion time** – Approximately 1 hour
- We recommend that two people install this product.
- Proper installation is the responsibility of the installer.
- Product failure due to improper installation is not covered under the Warranty.
- You **MUST** use all supplied parts and use proper installation procedures as described in these instructions when installing this air conditioner.

ELECTRICAL REQUIREMENTS



Some models require a 115/120-volt AC, 60-Hz grounded outlet protected with a 15-amp time-delay fuse or circuit breaker.

The 3-prong grounding plug minimizes the possibility of electric shock hazard. If the wall outlet you plan to use is only a 2-prong outlet, it is your responsibility to have it replaced with a properly grounded 3-prong wall outlet.



Some models require 230/208-volt AC, protected with a time-delay fuse or circuit breaker. These models should be installed on their own single branch circuit for best performance and to prevent overloading house or apartment wiring circuits, which could cause a possible fire hazard from overheating wires.



CAUTION

Do not, under any circumstances, cut or remove the third (ground) prong from the power cord.

Do not change the plug on the power cord of this air conditioner.

Aluminum house wiring may present special problems—consult a qualified electrician.

TOOLS YOU WILL NEED

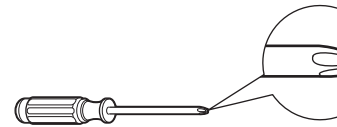

Phillips-head screwdriver

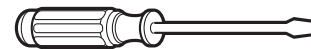

Flat-blade screwdriver



Pencil

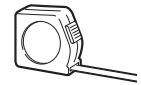

Ruler or tape measure



Level



Scissors or knife

Power cord includes a current interrupter device. A test and reset button is provided on the plug case. The device should be tested on a periodic basis by first pressing the **TEST** button and then the **RESET** button while plugged into the outlet. If the **TEST** button does not trip or if the **RESET** button will not stay engaged, discontinue use of the air conditioner and contact a qualified service technician.

Installation Instructions

PARTS INCLUDED (Appearance may vary)

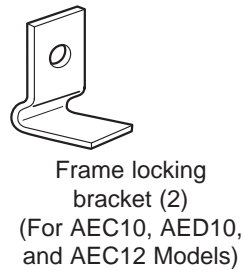
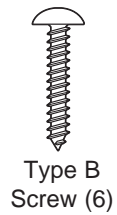
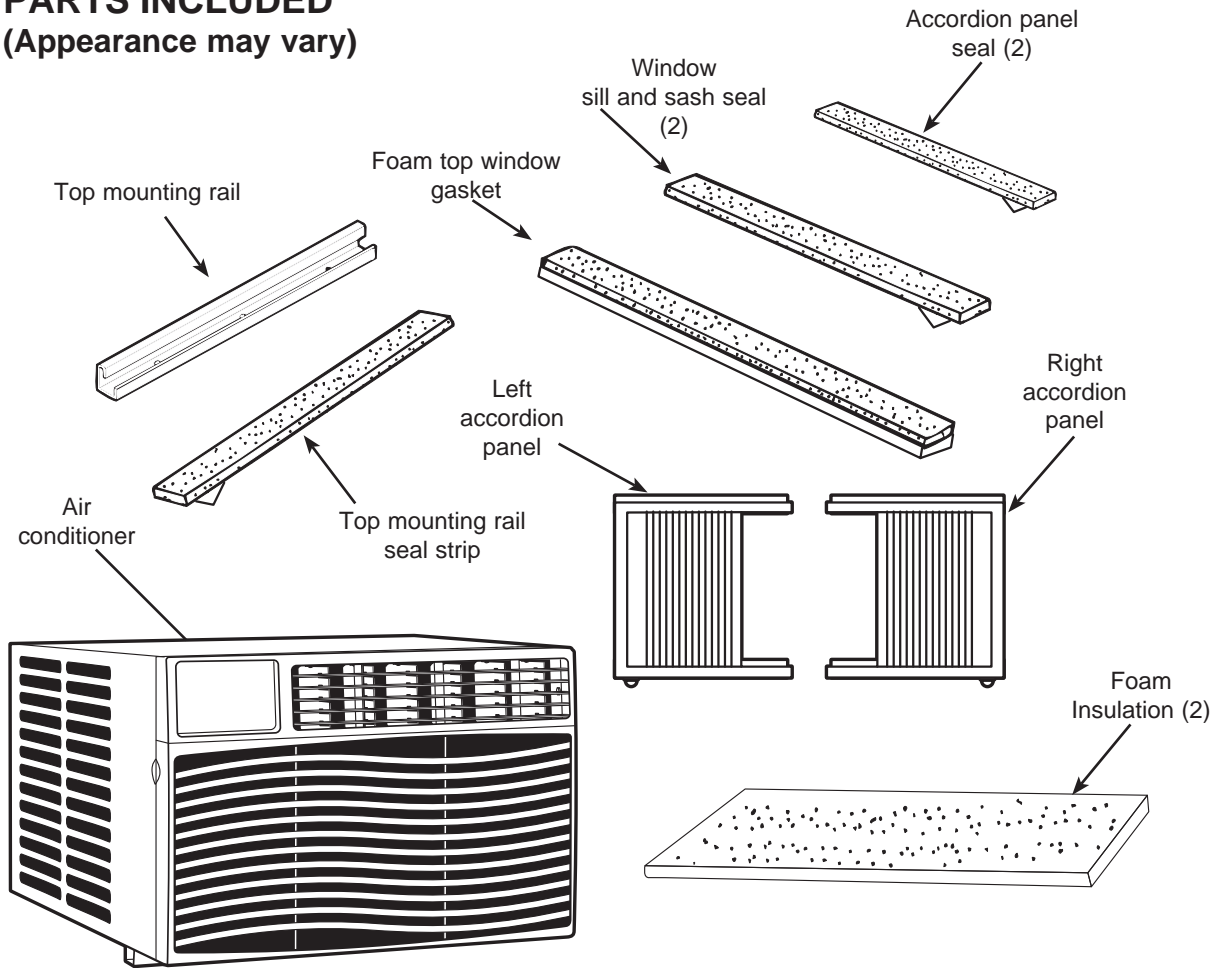

Installation Instructions

1 WINDOW REQUIREMENTS

- These instructions are for a standard double-hung window. You will need to modify them for other types of windows.
- The air conditioner can be installed without the accordion panels if needed to fit in a narrow window. See the window opening dimensions.
- All supporting parts must be secured to firm wood, masonry or metal.
- The electrical outlet must be within reach of the power cord.
- Follow the dimensions in the table and illustration for your model.

Models	A	B
AEC08	13-1/2" min.	24"-38"
AEC10, AED10 AEC12	18-1/6" min.	24"-36"

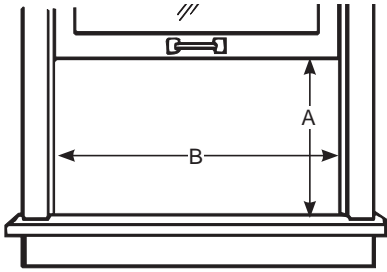

2 STORM WINDOW REQUIREMENTS

A storm window frame will not allow the air conditioner to tilt toward the outside, and will keep it from draining properly. To adjust for this, attach a piece of wood to the sill.

WOOD PIECES

WIDTH: 2"

LENGTH: Long enough to fit inside the window frame.

THICKNESS: To determine the thickness, place a piece of wood on the sill to make it 1/2" higher than the top of the storm window frame or the vinyl frame.

Attach securely with nails or screws provided by the installer.

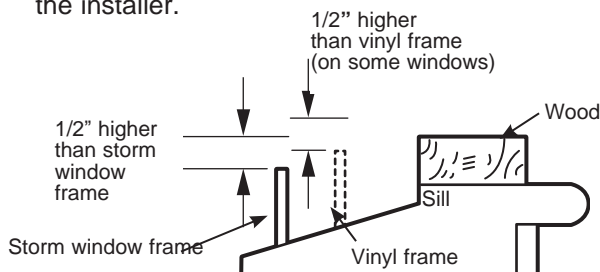

3 ATTACH THE TOP MOUNTING RAIL SEAL STRIP

(Some models may have the seal strip already attached to the top mounting rail. If applicable, skip this step.)

Remove the backing from the top mounting rail seal strip and attach the seal strip to the bottom of the top mounting rail, along the front edge.

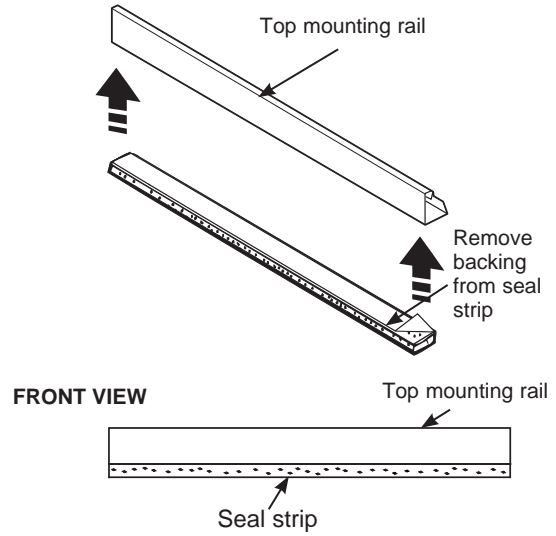

4 PREPARE THE AIR CONDITIONER

- A** Install the top mounting rail with 4 Type A screws from the outside of the case.

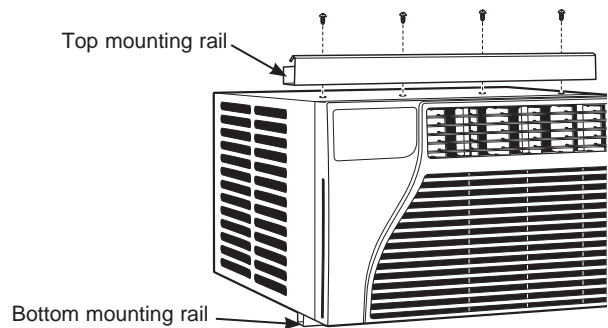

- B** Hold the accordion panel in one hand and gently pull back to free the open end.

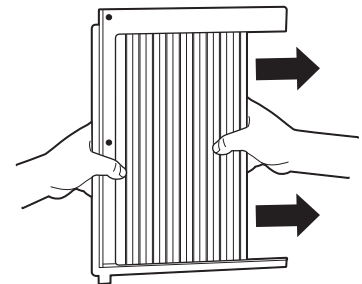

Installation Instructions

4 PREPARE THE AIR CONDITIONER (cont.)

- C** Remove the backing from the accordion seal (two short strips). Stick one sealing strip respectively on the left side and right side of the accordion panels, as shown.

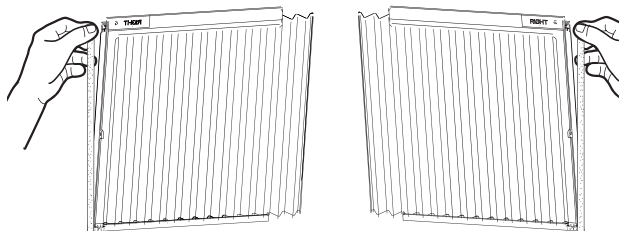

- D** Slide the free end of the accordion panel into the side panel rails. Slide the panel down. Be sure to leave enough space to slip the top and bottom of the frame into the rails on the cabinet.
- NOTE:** There is a right and a left accordion panel. Be sure to use the proper panel for each side.

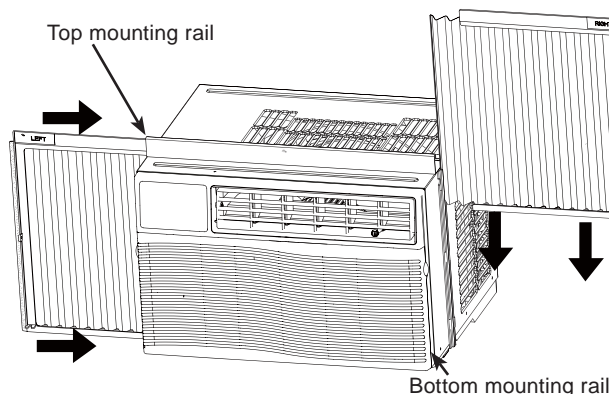

- E** Slide the left and right accordion panels into the top and bottom mounting rails.

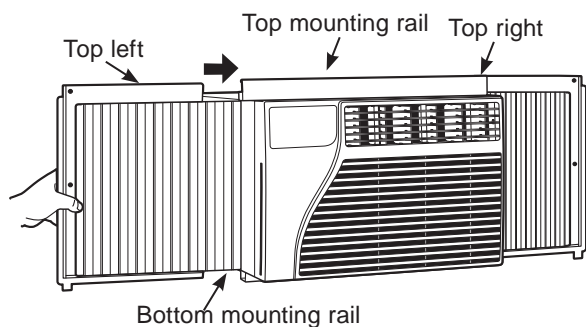

5 PREPARE THE WINDOW

Cut the window seal (2 long strips) to the proper length. Peel off the backing and attach the seal to the underside of the window sash. One attached to sash and one attached to sill.

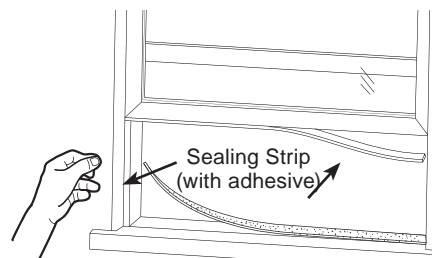

6 INSTALL THE AIR CONDITIONER IN THE WINDOW

- A** Place the air conditioner on the sill with the bottom mounting rail against its back edge. Center it and close the window securely behind the top mounting rail. It should be level or slightly tilted to the outside. Use a level; about a 1/3 bubble will be the correct case slant to the outside.

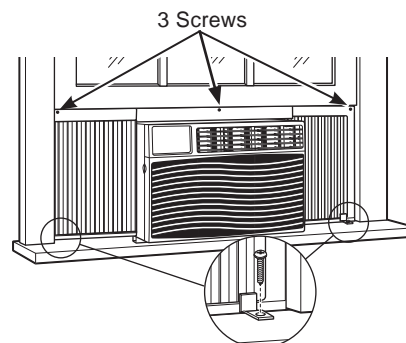

2 Frame locking brackets
(For AEC10 and AEC12 Models)

- B** Extend the left and right accordion panels to the vertical window sashes and attach 3 screws through the holes in the upper panels, as appropriate.

- C** **For AEC10 and AEC12 Models:** Install the frame locking brackets between the bottom of the accordion panel and the window sill. Attach with 2 screws.

NOTE: To prevent the window sill from splitting, drive the pilot holes before driving the screws.

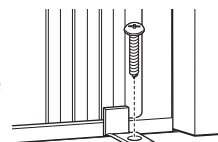

Installation Instructions

7 INSTALL SUPPORT BRACKET AND FOAM TOP WINDOW GASKET

A **CAUTION**

To prevent broken glass or damage to windows, on vinyl or other similarly constructed windows, attach the window locking bracket to the window side jamb with one screw.

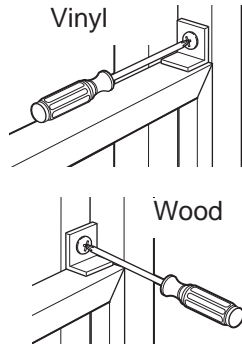

B Cut the foam top window gasket to the window width.

C Stuff the foam between the glass and the window to prevent air and insects from getting into the room.



NOTE: If the gasket supplied does not fit your window, obtain appropriate material locally to provide a proper installation seal.

8 INSTALL FOAM INSULATION

Additional insulation is provided with your window air conditioner to reduce heat leakage into the home, reducing overall energy usage.

A After the air conditioner is installed in the window measure the length of the accordion for both sides.

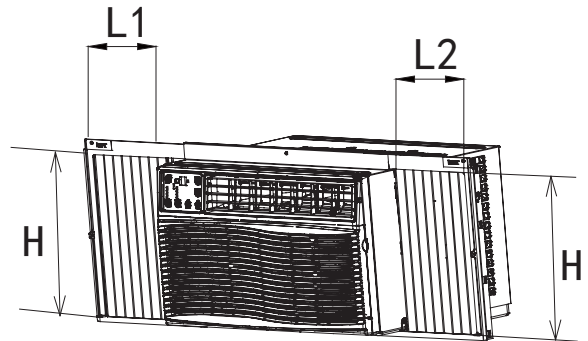

B Cut the foam insulation to the measured length of the left and right side accordion.

NOTE: Be sure to measure each accordion because the length could be different on each side.

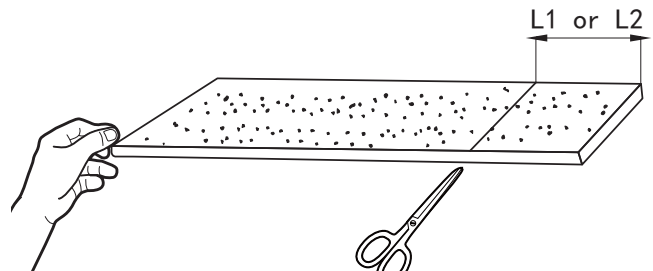

C Remove adhesive from back of foam insulation. Stick the foam insulation onto the left and right accordion, and inside of the frames.

NOTE: Be careful to cover the entire accordion.

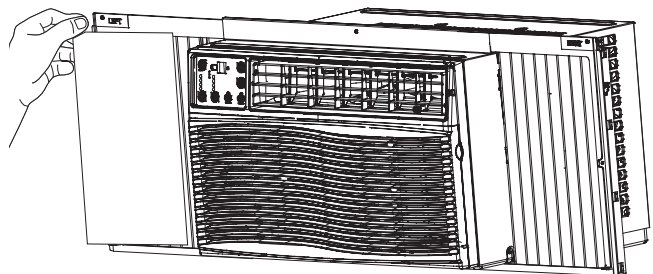

Troubleshooting Tips... Before you call for service

Save time and money! Review the charts on the following pages first and you may not need to call for service.

Problem	Possible Causes	What To Do
Air conditioner does not start	The air conditioner is unplugged.	•Make sure the air conditioner plug is pushed completely into the outlet.
	The fuse is blown/circuit breaker is tripped.	•Check the house fuse/circuit breaker box and replace the fuse or reset the breaker.
	Power failure.	•The unit will automatically re-start in the settings last used after the power is restored. •There is a protective time delay (approximately 3 minutes) to prevent tripping of the compressor overload. For this reason, the unit may not start normal cooling for 3 minutes after it is turned back on.
	The current interrupter device is tripped.	•Press the RESET button located on the power cord plug. •If the RESET button will not stay engaged, discontinue use of the air conditioner and contact a qualified service technician.
Air conditioner does not cool as it should	Airflow is restricted.	•Make sure there are no curtains, blinds or furniture blocking the front of the air conditioner.
	The temp control may not be set correctly.	•On models with touch pads: In the Cool mode, press the Decrease ▼ pad.
		•On models with control knobs, turn the temperature knob to a higher number.
	The air filter is dirty.	•Clean the filter at least every 30 days. See the Care and Cleaning section.
	The room may have been hot.	•When the air conditioner is first turned on, you need to allow time for the room to cool down.
	Cold air is escaping.	•Check for open furnace registers and cold air returns.
Cooling coils have iced up.	•See " Air conditioner freezing up " below.	
Air conditioner freezing up	Ice blocks the air flow and stops the air conditioner from cooling the room.	•On models with control knobs, set the mode control at High Fan or High Cool with the Temp at 1 or 2 .
		•On models with touch pads, set the controls at High Fan or High Cool and set the thermostat to a higher temperature.
The remote control is not working	The batteries are inserted incorrectly.	•Check the position of the batteries. They should be inserted in the opposite (+) and (-) direction.
	The batteries may be dead.	•Replace the batteries.
Water drips outside	Hot, humid weather.	•This is normal.
Water drips indoors	The air conditioner is not tilted to the outside.	•For proper water disposal, make sure the air conditioner slants slightly from the case front to the rear.
Water collects in base pan	Moisture removed from air and drains into base pan.	•This is normal for a short period in areas with little humidity; normal for a longer period in very humid areas.

Normal Operating Sounds

- You may hear a pinging noise caused by water being picked up and thrown against the condenser on rainy days or when the humidity is high. This design feature helps remove moisture and improve efficiency.
- You may hear the thermostat click when the compressor cycles on and off.
- Water will collect in the base pan during high humidity or on rainy days. The water may overflow and drip from the outdoor side of the unit.
- The fan may run even when the compressor does not.

Appliance Communication

GE Appliances WiFi Connect (for customers in the United States)

GE Appliances WiFi Connect Enabled* If your Air Conditioner (AC) has a Connected Appliance Information label located on the outside as shown below, your AC is **GE Appliances WiFi Connect Enabled**. A WiFi communication card is built into the product allowing it to communicate with your smart phone for remote monitoring, control and notifications. Please visit www.GEAppliances.com/connect to learn more about connected appliance features, and to learn what connected appliance apps will work with your smart phone.

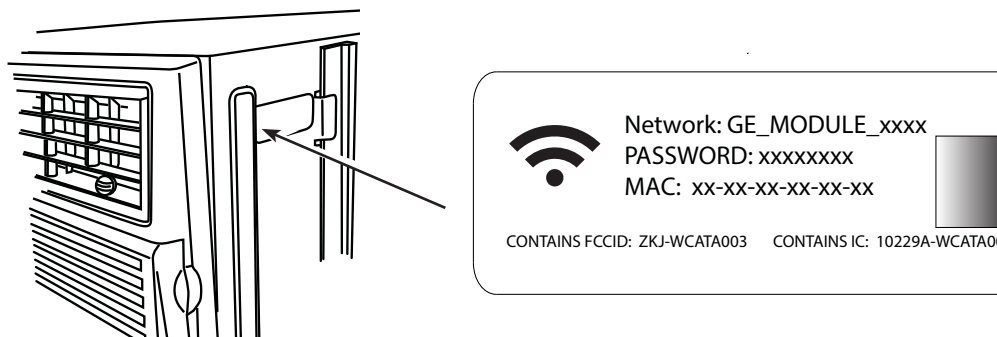

WiFi Connectivity: For assistance with the appliance or the **ConnectPlus** network connectivity (for models that are WiFi enabled or WiFi optional), please call **1-800-220-6899**.

REGULATORY INFORMATION

FCC/IC Compliance Statement:

This device complies with Part 15 of the FCC Rules. Operation is subject to the following two conditions:

1. This device may not cause harmful interference.
2. This device must accept any interference received, including interference that may cause undesired operation.

This equipment has been tested and found to comply with the limits for a Class B digital device, pursuant to Part 15 of the FCC Rules. These limits are designed to provide reasonable protection against harmful interference in a residential installation. This equipment generates uses and can radiate radio frequency energy and, if not installed and used in accordance with the instructions, may cause harmful interference to radio communications. However, there is no guarantee that interference will not occur in a particular installation. If this equipment does cause harmful interference to radio or television reception, which can be determined by turning the equipment off and on, the user is encouraged to try to correct the interference by one or more of the following measures:

- Reorient or relocate the receiving antenna.
- Increase the separation between the equipment and receiver.
- Connect the equipment into an outlet on a circuit different from that to which the receiver is connected.
- Consult the dealer or an experienced radio/television technician for help.

Labelling: Changes or modifications to this unit not expressly approved by the manufacturer could void the user's authority to operate the equipment.

*Select Models Only

GE Appliances Air Conditioner - One-Year Limited Warranty

WARRANTY

All warranty service provided by our Factory Service Centers, or an authorized Customer Care® technician. To schedule service, visit us on-line at ge.com, or call 800.GE.CARES (800.432.2737). Have serial number and model number available when calling for service.

For The Period Of:	GE Appliances Will Replace:
One Year From the date of the original purchase	Replacement unit for any product which fails due to a defect in materials or workmanship. During this limited one-year warranty, GE Appliances will also provide, free of charge, all labor and related service to replace the defective part.

What GE Appliances Will Not Cover:

- Service trips to your home to teach you how to use the product.
- Improper installation, delivery or maintenance. If you have an installation problem, or if the air conditioner is of improper cooling capacity for the intended use, contact your dealer or installer. You are responsible for providing adequate electrical connecting facilities.
- Failure of the product resulting from modifications to the product or due to unreasonable use including failure to provide reasonable and necessary maintenance.
- In commercial locations, labor necessary to move the unit to a location where it is accessible for service by an individual technician.
- Replacement of house fuses or resetting of circuit breakers.
- Failure due to corrosion on models not corrosion-protected.
- Damage to the product caused by improper power supply voltage, accident, fire, floods or acts of God.
- Incidental or consequential damage caused by possible defects with this air conditioner.
- Damage caused after delivery.

EXCLUSION OF IMPLIED WARRANTIES—Your sole and exclusive remedy is product repair as provided in this Limited Warranty. Any implied warranties, including the implied warranties of merchantability or fitness for a particular purpose, are limited to one year or the shortest period allowed by law.

This warranty is extended to the original purchaser and any succeeding owner for products purchased for home use within the USA. If the product is located in an area where service by a GE Appliances Authorized Servicer is not available, you may be responsible for a trip charge or you may be required to bring the product to an Authorized GE Appliances Service location for service. In Alaska, the warranty excludes the cost of shipping or service calls to your home.

Some states do not allow the exclusion or limitation of incidental or consequential damages. This warranty gives you specific legal rights, and you may also have other rights which vary from state to state. To know what your legal rights are, consult your local or state consumer affairs office or your state's Attorney General.

Warrantor: GE Appliances

Staple your receipt here. Proof of the original purchase date is needed to obtain service under the warranty.

Consumer Support

GE Appliances Website

Have a question or need assistance with your appliance? Try the GE Appliances Website 24 hours a day, any day of the year! You can also shop for more great GE Appliances products and take advantage of all our on-line support services designed for your convenience. In the US: GEAppliances.com

Register Your Appliance

Register your new appliance on-line at your convenience! Timely product registration will allow for enhanced communication and prompt service under the terms of your warranty, should the need arise. You may also mail in the pre-printed registration card included in the packing material. In the US: GEAppliances.com/register

Schedule Service

Expert GE Appliances repair service is only one step away from your door. Get on-line and schedule your service at your convenience any day of the year. In the US: GEAppliances.com/ge/service-and-support/service.htm or call 800.432.2737 during normal business hours.

Extended Warranties

Purchase a GE Appliances extended warranty and learn about special discounts that are available while your warranty is still in effect. You can purchase it on-line anytime. GE Appliances Services will still be there after your warranty expires. In the US: GEAppliances.com/ge/service-and-support/shop-for-extended-service-plans.htm or call 800.626.2224 during normal business hours.

Remote Connectivity

For assistance with wireless network connectivity (for models with remote enable), visit our website at GEAppliances.com/ge/connected-appliances/ or call 800.220.6899 in the US.

Parts and Accessories

Individuals qualified to service their own appliances can have parts or accessories sent directly to their homes (VISA, MasterCard and Discover cards are accepted). Order on-line today 24 hours every day. In the US: GEApplianceparts.com or by phone at 877.959.8688 during normal business hours.

Instructions contained in this manual cover procedures to be performed by any user. Other servicing generally should be referred to qualified service personnel. Caution must be exercised, since improper servicing may cause unsafe operation.

Contact Us

If you are not satisfied with the service you receive from GE Appliances, contact us on our Website with all the details including your phone number, or write to:

In the US: General Manager, Customer Relations | GE Appliances, Appliance Park | Louisville, KY 40225
GEAppliances.com/ge/service-and-support/contact.htm