

EN FRENCH DOOR BOTTOM
FREEZER/REFRIGERATOR

FR RÉFRIGÉRATEUR À PORTES
FRANÇAISES/CONGÉLATEUR EN BAS

ES REFRIGERADOR CON CONGELA-
DOR INFERIOR DE PUERTA DOBLE

USE AND CARE GUIDE

GUIDE D'UTILISATION ET D'ENTRETIEN

GUIA DE USO Y CUIDADO



Please read and save this guide

Thank you for choosing Electrolux, our new premium brand in home appliances. This Use & Care Guide is part of our commitment to customer satisfaction and product quality throughout the service life of your new appliance.

Keep a record for quick reference

Purchase date

Electrolux model number

Electrolux serial number



NOTE

Registering your product with Electrolux enhances our ability to serve you. You can register online at www.electroluxappliances.com or by sending your Product Registration Card in the mail.

Questions?

For toll-free telephone support in the U.S. and Canada: 1-877-4ELECTROLUX (1-877-435-3287)

For online support and product information visit <http://www.electroluxappliances.com>

Table of contents

Finding Information	2
Safety	3
Feature Overview.....	5
Installation	6
Removing the Doors.....	11
Installing Door Handles.....	13
Connecting the Water Supply.....	14
Controls	16
Automatic Ice & Water Maker/Dispenser.	21
Automatic Ice Maker - Freezer	23
Storage Features	24
Storing Food and Saving Energy.....	29
Normal Operating Sounds	30
Changing the Water and Air Filters....	31
Care and Cleaning.....	33
Solutions to Common Problems.....	36
Warranty.....	41

Installation Checklist

Doors

- Handles are secure and tight
- Door seals completely to cabinet on all sides
- Freezer drawer is level across top

Leveling

- Refrigerator is level, side-to-side and tilted ¼ (6mm) front-to-back
- Toe grille is properly attached to refrigerator
- Cabinet is setting solid on all corners

Electrical Power

- House power turned on
- Refrigerator plugged in

Ice Maker

- House water supply connected to refrigerator
- No water leaks present at all connections - recheck in 24 hours
- Ice maker is turned ON
- Ice & water dispenser operates correctly
- Front filter must be flush with filter housing (select models)

Final Checks

- Shipping material removed
- Fresh food and freezer temperatures set
- Crisper humidity controls set
- Registration card sent in

Important safety instructions

Safety Precautions

Do not attempt to install or operate your unit until you have read the safety precautions in this manual. Safety items throughout this manual are labeled with a Danger, Warning, or Caution based on the risk type.

Definitions

 This is the safety alert symbol. It is used to alert you to potential personal injury hazards. Obey all safety messages that follow this symbol to avoid possible injury or death.



DANGER

DANGER indicates an imminently hazardous situation which, if not avoided, will result in death or serious injury.



WARNING

WARNING indicates a potentially hazardous situation which, if not avoided, could result in death or serious injury.



CAUTION

CAUTION indicates a potentially hazardous situation which, if not avoided, may result in minor or moderate injury.



IMPORTANT

Indicates installation, operation, or maintenance information which is important but not hazard-related.

General Safety



WARNING

Please read all safety instructions before using your new refrigerator.

- Do not store or use gasoline or other flammable liquids near this or any other appliance. Read product labels for warnings regarding flammability and other hazards.

- Do not operate the refrigerator in the presence of explosive fumes.
- Avoid contact with any moving parts of the automatic ice maker.
- Remove all staples from the carton to avoid injury. Staples can also damage finishes if they come in contact with other appliances or furniture.

Child Safety

Packing Materials:

- Packing cartons covered with rugs, bedspreads, plastic sheets, or stretch wrap may become airtight chambers and can quickly cause suffocation.
- Destroy or recycle the product's carton, plastic bags, and any other exterior wrapping material immediately after the refrigerator is unpacked. Children should never play with these items.

Child Entrapment and Suffocation:

- These problems are not limited to the past. Whether junked, abandoned, or temporarily stored (even for a few hours), unattended refrigerators and freezers are dangerous. Please take the precautions listed below.

Proper Disposal of Refrigerators/Freezers

We strongly encourage responsible appliance recycling/disposal methods. Check with your utility company or visit www.energystar.gov/recycle for more information on recycling your old refrigerator.

Before you recycle or dispose of your old refrigerator/freezer:

- Remove the doors.
- Leave the shelves and baskets in place so children may not easily climb inside.
- Have refrigerant and compressor oil removed by a qualified service technician.

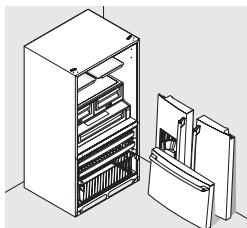

Electrical information



WARNING

You must follow these guidelines to ensure that your refrigerator's safety mechanisms are operating correctly.

- The refrigerator must be plugged into its own dedicated 115 Volt, 60 Hz, AC-only non-GFCI electric outlet. The power cord of the appliance is equipped with a three-prong grounding plug for your protection against electrical shock hazards. It must be plugged directly into a properly grounded three-prong receptacle. The receptacle must be installed in accordance with local codes and ordinances. Consult a qualified electrician. Do not use an extension cord or adapter plug.
- If the power cord is damaged, it should be replaced by the manufacturer, service technician, or a qualified person.
- Never unplug the refrigerator by pulling on the power cord. Always grip the plug firmly and pull straight out from the receptacle to prevent damaging the power cord.
- To avoid electrical shock, unplug the refrigerator before cleaning and before replacing a light bulb or LED light.
- Performance may be affected if the voltage varies by 10% or more. Operating the refrigerator with insufficient power can damage the compressor. Such damage is not covered under your warranty.
- Do not plug the unit into an outlet controlled by a wall switch or pull cord to prevent the refrigerator from being turned off accidentally.

Grounding type wall receptacle

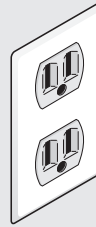

Do not, under any circumstances, cut, remove, or bypass the grounding prong.

Power cord with 3-prong grounded plug



IMPORTANT

To turn off power to your refrigerator, unplug the power cord from the wall outlet.

Understanding features and terms

Your Electrolux refrigerator is designed for optimal convenience and storage flexibility. The illustration below is provided to assist you with familiarizing yourself with product features and terminology.



NOTE

*Features may vary according to model. Model is shown without freezer drawer cover.

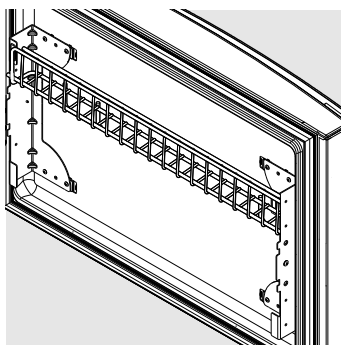
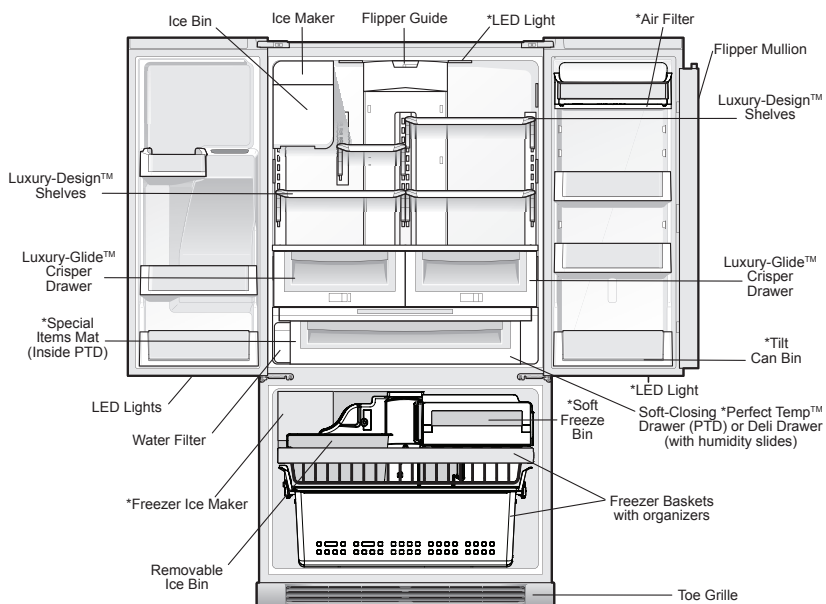

***Wire Shelf**
(inside freezer drawer)



IMPORTANT

Features not included with your refrigerator can be purchased at www.electroluxappliances.com or by calling 1-877-435-3287.

Required Tools

You will need the following tools:

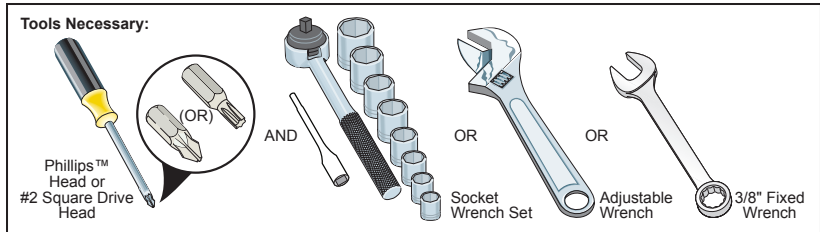

Components Provided:

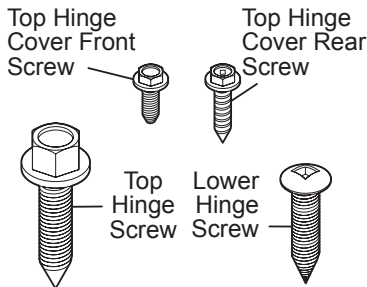

This Use & Care Guide provides general installation and operating instructions for your model. We recommend using a service or kitchen contracting professional to install your refrigerator. Use the refrigerator only as instructed in this Use & Care Guide. Before starting the refrigerator, follow these important first steps.

Location

- Choose a place that is near a grounded, non-GFCI, electrical outlet. Do Not use an extension cord or an adapter plug.
- If possible, place the refrigerator out of direct sunlight and away from the range, dishwasher, or other heat sources.
- The refrigerator must be installed on a floor that is level and strong enough to support a fully loaded refrigerator.
- Consider water supply availability for models equipped with an automatic ice maker.



CAUTION

DO NOT install the refrigerator where the temperature will drop below 55° F (13° C) or rise above 110° F (43° C). The compressor will not be able to maintain proper temperatures inside the refrigerator.

DO NOT block the toe grille on the lower front of your refrigerator. Sufficient air circulation is essential for the proper operation of your refrigerator.

Installation

- Allow the following clearances for ease of installation, proper air circulation, and plumbing and electrical connections:

Sides & Top	3/8 inch (9.5 mm)
Back	1 inch (25.4 mm)



NOTE

If your refrigerator is placed with the door hinge against a wall, you may have to allow additional space so the door can be opened wider.

Door opening



NOTE

The refrigerator doors are designed to shut by themselves within a 20 degree opening.

Your refrigerator should be positioned to allow easy access to a counter when removing food. For best use of refrigerator drawers and freezer baskets, the refrigerator should be in a position where both can be fully opened.



CAUTION

Do Not loosen or remove these 3 hex screws.

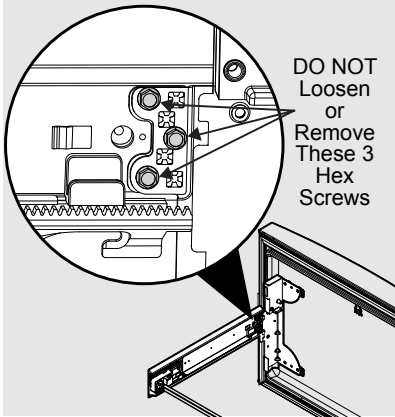

Cabinet Leveling & Refrigerator Door Alignment (if necessary)

Guidelines for final positioning of your refrigerator:

- All four corners of the cabinet must rest firmly on the floor.
- The sides should tilt $\frac{1}{4}$ inch (6 mm) from front to back (to ensure that doors close and seal properly).
- Doors should align with each other and be level.

Most of these conditions can be met by raising or lowering the adjustable front rollers.

To level the cabinet using the front rollers:

- 1 Slightly open freezer drawer. Lift the toe grille and gently pull forward (see illustration).
- 2 You can raise or lower each door. Use a $\frac{3}{8}$ inch socket wrench to turn the adjustment screws (1 per side).

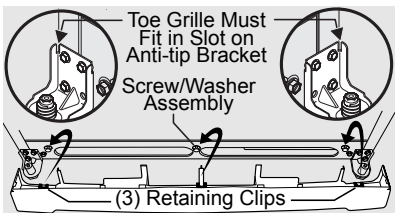

To raise: turn adjustment screw clockwise.

To lower: turn adjustment screw counterclockwise.

- 3 Ensure both doors are bind-free with their seals touching the cabinet on all four sides and that cabinet is stable.
- 4 After unit is leveled, lower anti-tip leg until it contacts the floor.

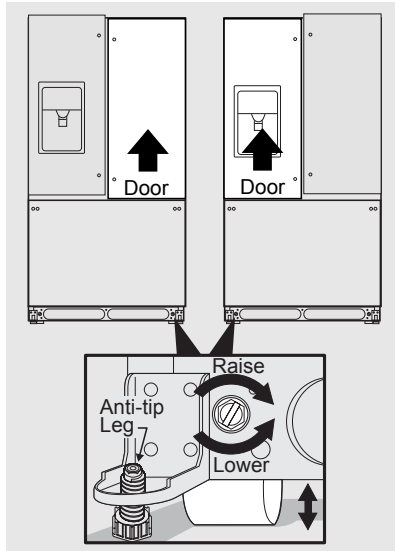

- 5 Install the toe grille by fitting into place.

8 Installation

To adjust the door stop:

Door stop is adjustable between 85 to 145 degrees.



NOTE

View shown is looking up at the bottom of the refrigerator door.

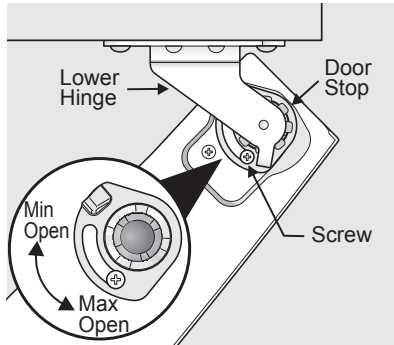

Adjustable Door Stop

- 1 Open door to provide access to screw.
- 2 Loosen screw.
- 3 Adjust door to desired location.

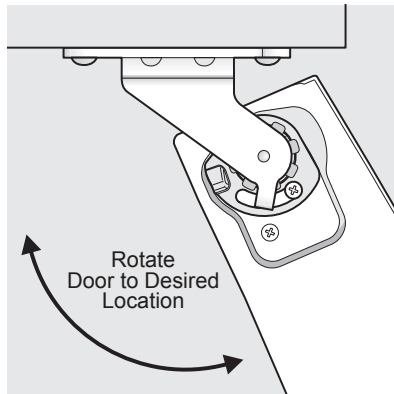

Adjusting Door

- 4 Rotate door stop until it makes contact with the lower hinge.

- 5 Re-tighten screw.

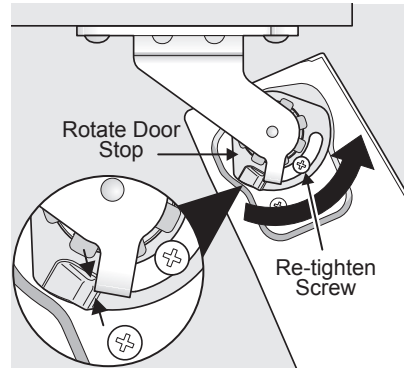

Re-tighten Screw

- 6 Ensure door stops in desired location before resuming normal use.

To level the doors using the adjustable lower hinge (select models):

- 1 Remove all food items from door bins on door being adjusted.
- 2 Open doors to 90 degrees.

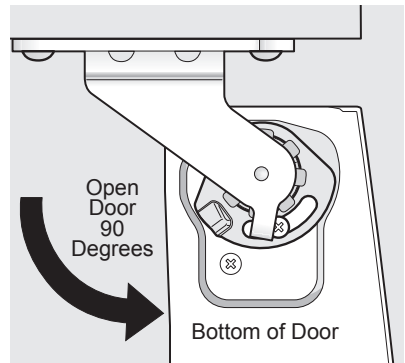

NOTE

Adjustable hinge should only be used after doors have been leveled with rollers.

- 3 Lift the door while adjusting the washer. To raise the door, rotate washer clockwise (when viewed from the bottom). To lower door, rotate washer counter-clockwise (when viewed from the bottom).

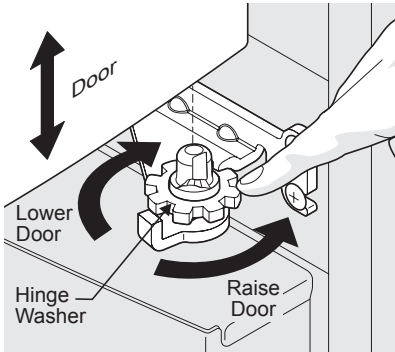

Raising/Lowering Door

To adjust the flipper mullion:

- 1 Loosen the screw located on the flipper mullion hinge.

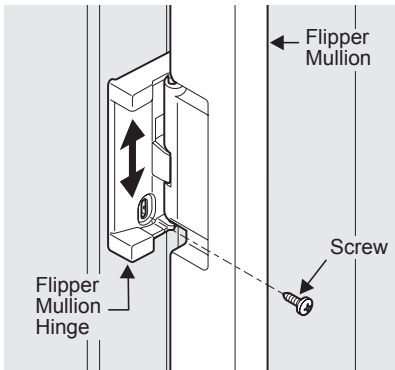

Adjusting Flipper Mullion Screw

- 2 Adjust flipper mullion height. For proper connection with the flipper mullion guide, there should be a separation about the thickness of a coin (0.060 inches, or 1.5 mm) between the guide and flipper mullion.

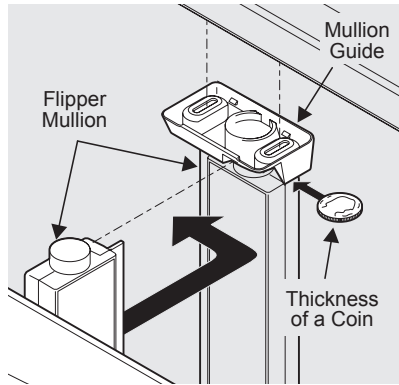

Adjusting Flipper Mullion Height

- 3 Re-tighten screw.

10 Installation

Installing Shelves

Your refrigerator was shipped with the shelf hanger and shelf locking clip installed in their shipping position. Below are the instructions to install the shelves in your desired locations.

- 1 Remove shelf from its locked position by pulling the slide mechanism toward you.

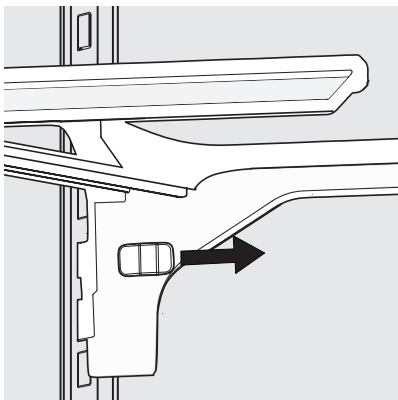

- 2 Lift the hanger directly upwards and pull toward you to remove it from the ladder.

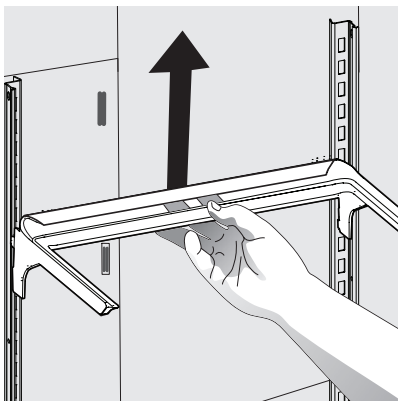

- 3 Place top hooks of the hanger into the desired slot, and lower straight down until lower hooks rest on the ladder.



CAUTION

Shelves must be removed prior to moving the refrigerator.

- 4 Relock shelf by pushing the slide mechanism away from you.

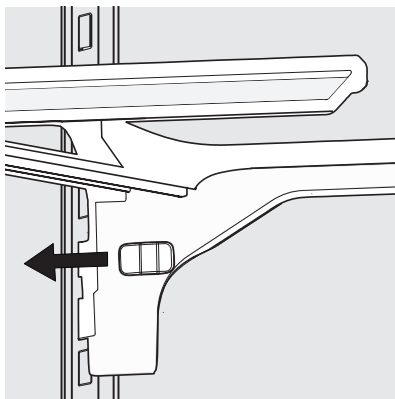

- 5 While holding shelf at a 45-degree angle with the gray handle facing you, push the shelf into the back of the hanger.

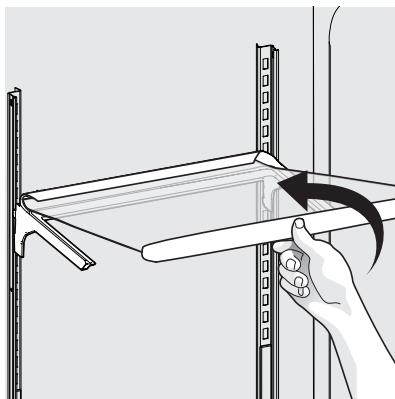

- 6 Gently set the shelf onto the hanger once the back is secured by the hanger.

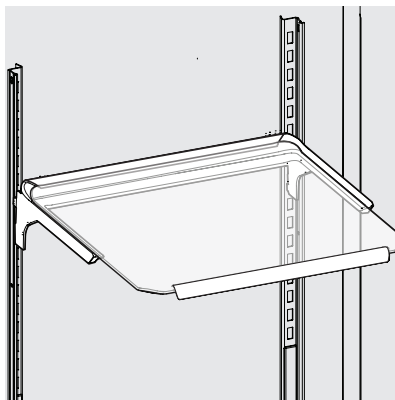

Getting through narrow spaces

If your refrigerator will not fit through an entrance area, you can remove the doors. Check first by measuring the entrance.

To prepare for removing the doors:

- 1 Make sure the electrical power cord is unplugged from the wall outlet.
- 2 Open the freezer drawer and remove the toe grille (see Installation section).
- 3 Remove any food from the door shelves and close the doors.

To remove the top hinge covers:

- 1 Remove the two screws from each cover over the top door hinges.
- 2 Lift inside edge of hinge cover and tilt back.

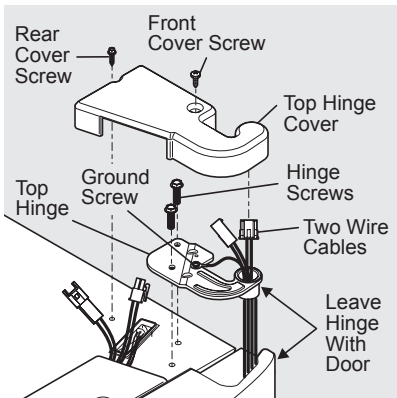
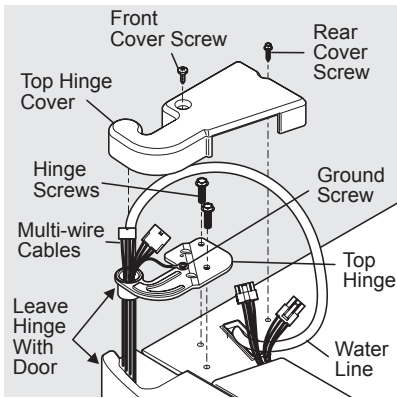

NOTE

DO NOT remove the ground screw from hinge.

To remove the refrigerator doors:

- 1 Trace lightly around the door's top hinges with a pencil. This makes reinstallation easier.

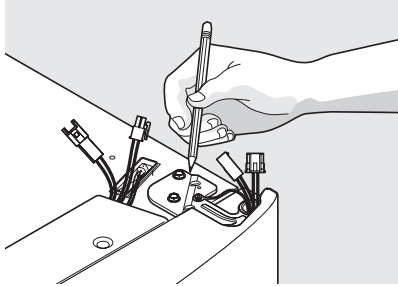

- 2 Disconnect the harness by grasping both sides of the connector firmly, depress the latch, and pull apart. Remove the two screws from the top hinge. Lift the door off of the bottom hinge and set it aside.

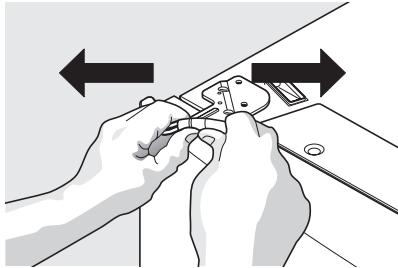

- 3 Detach the water tube from the connector located behind the refrigerator and pull the tube back out to the front of the unit. The connector releases when you press inward on the outer sleeve while pushing the tube toward the connector then while continuing to hold in the sleeve, pull the tube away.

12 Removing the Doors

- 4 Unscrew the three lower hinge screws and hinge if necessary.



NOTE

Use care while pulling the water tube from the unit to be sure that you do not kink the tube.

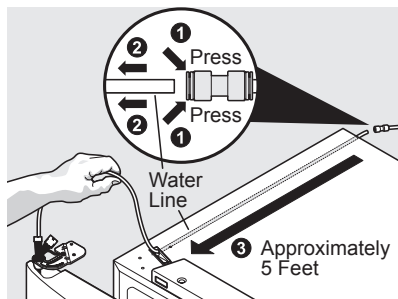

NOTE

You will be pulling approximately five feet of water tube from the back of the refrigerator.

To reinstall the right door, reverse the above steps.

Lower Hinge Removal

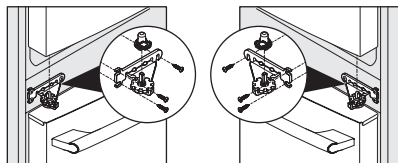

Once both doors are in place, ensure they are aligned with each other and level (Please see the **Installation** section for more details), and replace the top hinge cover.



NOTE

When reinserting the water tube and replacing the top hinge cover, use care to be sure you do not kink the tube.



CAUTION

Be sure doors are set aside in a secure position where they cannot fall and cause personal injury, or damage to the doors or handles.



CAUTION

Drawer is heavy. Use caution when lifting.

Removing Freezer Drawer

- 1 Remove 4 hex head drawer screws.
- 2 Lift up drawer to remove.

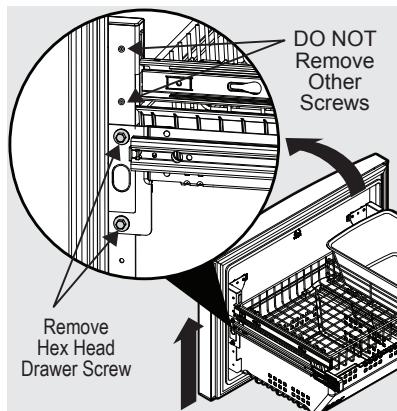

Replacing Freezer Drawer

- 1 Lower drawer back into place.
- 2 Replace 4 hex head drawer screws and tighten.

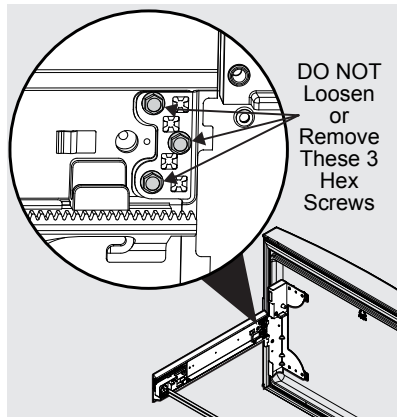

Door Handle Mounting Instructions

- 1 Remove handles from protective packaging.
- 2 Position fresh food handle end caps (A) over upper and lower pre-installed shoulder bolts (B) that are fastened into door, ensuring the holes for the set screws are facing towards the opposite door.
- 3 While holding handle firmly against door, fasten upper and lower Allen set screws (C) with supplied Allen wrench.
- 4 Repeat steps 2 and 3 to install opposite handle. Ensure the holes for the set screws are facing towards the first door.
- 5 Position freezer handle end caps over left and right pre-installed shoulder bolts that are fastened to the drawer, ensuring the holes for the set screws are facing down.
- 6 While holding handle firmly against drawer, fasten left and right Allen set screws (C) with supplied Allen wrench.

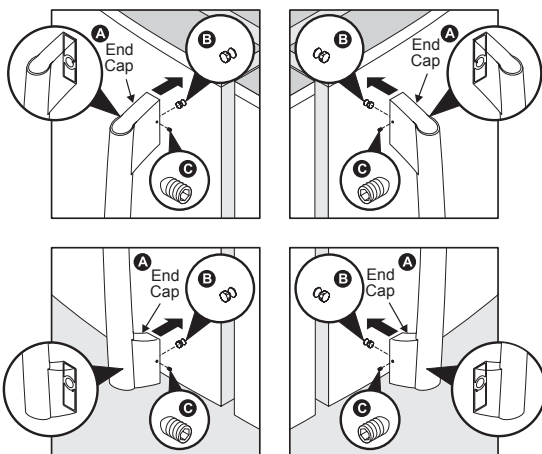

Mounting Refrigerator Handles

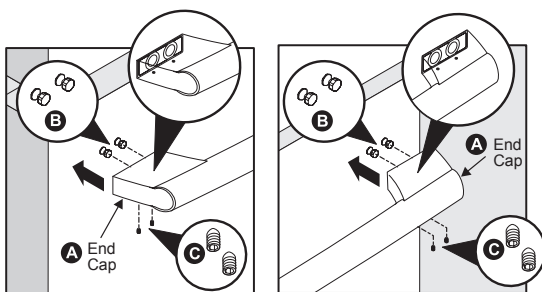

Mounting Freezer Handle



NOTE

To ensure that handles are flush with doors/drawer, make sure that set screws are completely tightened.



CAUTION

Wear gloves and safety goggles. Use extreme CAUTION when installing these handles.

14 Connecting the Water Supply



WARNING

To avoid electric shock, which can cause death or severe personal injury, disconnect the refrigerator from electrical power before connecting a water supply line to the refrigerator.



CAUTION

To Avoid Property Damage:

- Copper or Stainless Steel braided tubing is recommended for the water supply line. Water supply tubing made of ¼ inch plastic is not recommended to be used. Plastic tubing greatly increases the potential for water leaks, and the manufacturer will not be responsible for any damage if plastic tubing is used for the supply line.
- DO NOT install water supply tubing in areas where temperatures fall below freezing.
- Chemicals from a malfunctioning softener can damage the ice maker. If the ice maker is connected to soft water, ensure that the softener is maintained and working properly.



IMPORTANT

Ensure that your water supply line connections comply with all local plumbing codes.

Before installing the water supply line, you will need:

1. Basic Tools: adjustable wrench, flat-blade screwdriver, and Phillips™ screwdriver
2. Access to a household cold water line with water pressure between 30 and 100 psi.
3. A water supply line made of ¼ inch (6.4 mm) OD, copper or stainless steel tubing. To determine the length of tubing needed, measure the distance from the ice maker inlet valve at the back of the refrigerator to your cold water pipe. Then add approximately 7 feet (2.1 meters), so the refrigerator can be moved out for cleaning (as shown).

4. A shutoff valve to connect the water supply line to your household water system. DO NOT use a self-piercing type shutoff valve.
5. Do NOT reuse compression fitting or use thread seal tape.
6. A compression nut and ferrule (sleeve) for connecting a copper water supply line to the ice maker inlet valve.



NOTE

Check with your local building authority for recommendations on water lines and associated materials prior to installing your new refrigerator. Depending on your local/state building codes, Electrolux recommends for homes with existing valves its Smart Choice® water line kit 5305513409 with a 6 ft. (1.8 meters) Stainless Steel Water Line and for homes without an existing valve, Electrolux recommends its Smart Choice® water line kit 5305510264 with a 20 ft. (6 meters) Copper Water Line with self-tapping saddle valve). Please refer to www.electroluxappliances.com for more information.

To connect water supply line to ice maker inlet valve:

1. Disconnect refrigerator from electric power source.
2. Place end of water supply line into sink or bucket. Turn ON water supply and flush supply line until water is clear. Turn OFF water supply at shutoff valve.
3. Remove plastic cap from water valve inlet and discard cap.
4. If you use copper tubing - Slide brass compression nut, then ferrule (sleeve) onto water supply line. Push water supply line into water valve inlet as far as it will go ($\frac{1}{4}$ inch / 6.4 mm). Slide ferrule (sleeve) into valve inlet and finger tighten compression nut onto valve. Tighten another half turn with a wrench; DO NOT over tighten. See Figure 1.

If you use braided flexible stainless steel tubing - The nut is already assembled on the tubing. Slide nut onto valve inlet and finger tighten nut onto valve. Tighten another half turn with a wrench; DO NOT over tighten. See Figure 2.

5. With steel clamp and screw, secure water supply line (copper tubing only) to rear panel of refrigerator as shown.
6. Coil excess water supply line (copper tubing only), about $2\frac{1}{2}$ turns, behind refrigerator as shown and arrange coils so they do not vibrate or wear against any other surface.
7. Turn ON water supply at shutoff valve and tighten any connections that leak.
8. Reconnect refrigerator to electrical power source.
9. To turn ice maker on, lower wire signal arm (freezer ice maker) or set the ice maker's On/Off power switch to the On position (fresh food ice maker).

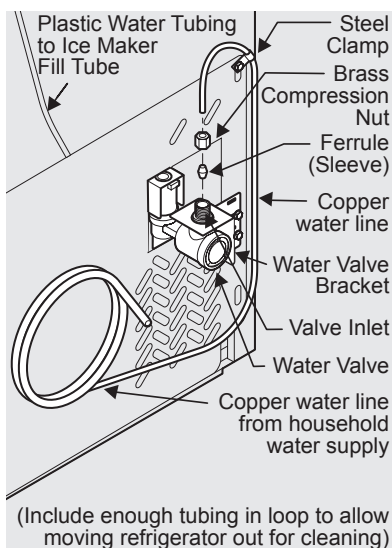

Figure 1

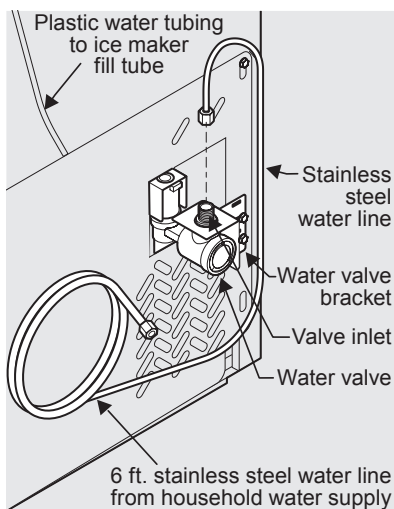
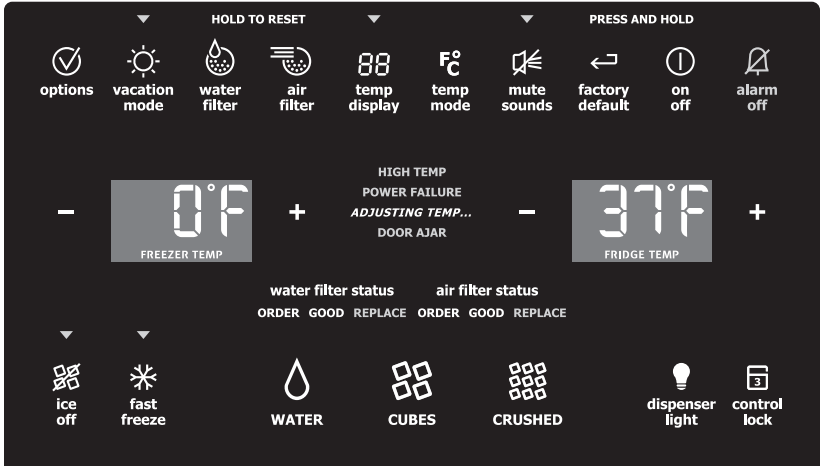

Figure 2

16 Controls

Wave-Touch™



IQ-Touch™

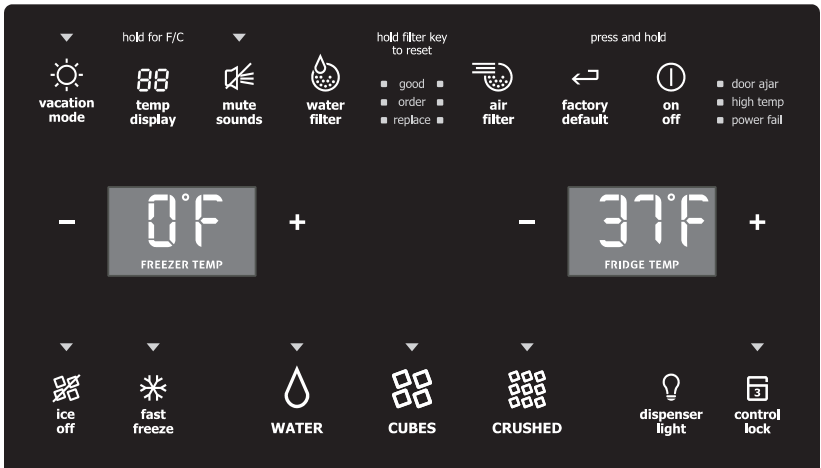

Wave-Touch™ (select models)

Your refrigerator is equipped with a Wave-Touch™ control panel display. It is only necessary to gently touch the glass. There are three levels of display.

1st Level: Sleep Mode

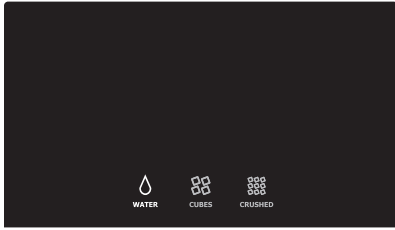

Sleep Mode displays only the water, cubes and crushed options. Touch an icon to activate the desired dispenser mode. The active dispenser mode is more brightly illuminated.

2nd Level: Awakened Display Mode

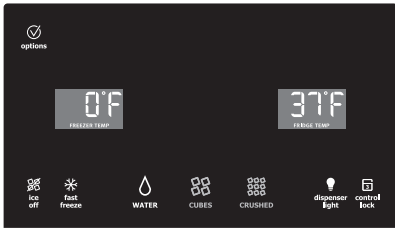

The control panel is awakened by touching anywhere on the glass where there is an indicator. Black space will not awaken the display. After 10 seconds of inactivity, the control panel will return to the Sleep mode.

The following dispenser options are illuminated:

ice off	Press and hold for three seconds to turn the ice maker ON or OFF. The ice maker is OFF when the LED above the Ice Off icon is illuminated. If there is no indicator, then the ice maker is ON. Turning the ice maker OFF disables the ice dispensing feature. Neither CUBES nor CRUSHED will operate with the ice maker OFF.
(Fresh Food Ice Maker)	
fast freeze	Activates a faster rate for freezing food and increased ice production.

NOTE

Refer to Automatic Ice Maker-Freezer section for freezer ice maker controls.

dispenser light	On / Off
control lock	Press and hold for three seconds to activate and deactivate. This restricts undesired changes to the refrigerator's settings and prevents use of the ice and water dispenser.

IMPORTANT

When the ice maker is turned off, the ice in the bucket should be transferred to the freezer or discarded to prevent it from melting.

3rd Level: User Variable Options

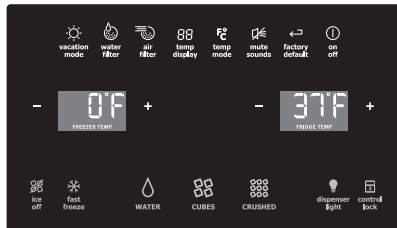

Touching the options icon displays the following options:

vacation mode	Conserves energy by increasing the time between automatic defrost. This feature is automatically activated during long periods between door openings. Vacation mode is manually activated when the indicator is lit.
water filter	Touch to display filter condition status. Press and hold for three seconds to reset after filter change.
air filter	Touch to display filter status. Press and hold for three seconds to reset after filter change.
temp display	When active, it allows the display of the freezer and fridge temps during Sleep Mode. The temperature is displayed when the indicator is lit.
temp mode	Touch to toggle display from Fahrenheit to Celsius.

18 Controls

mute sounds	Tones emitted by each keypress can be turned off based on user preference. The sounds are muted when the indicator is lit. Warning signals will stay active.
factory default	Resets all refrigerator settings such as temp, temp display, and alarm tones to their factory default settings.
on off	Press and hold for three seconds to turn off the cooling system to clean the refrigerator. It also turns off the ice maker, all dispenser functions, and the Perfect Temp™ drawer (select models). The temperature display will read OFF.

▶ IMPORTANT

Pressing the system on/off icon does not turn off power to your refrigerator. You must unplug the power cord from the wall outlet.

Setting cooling temperatures

- 1 Touch the glass panel to illuminate the 2nd level of display.
- 2 Select the options icon. Plus (+) and minus (-) indicators will appear on either side of the displayed temperatures.
- 3 Press the + or - indicator to adjust the temperature to the desired setting.

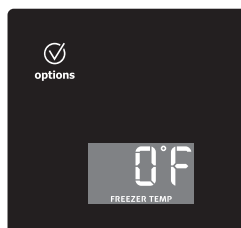

The temperature display will begin to blink with the first touch. After five seconds of inactivity, the display will beep to accept the new temperature. After 10 seconds, the display times out and returns to the basic display.

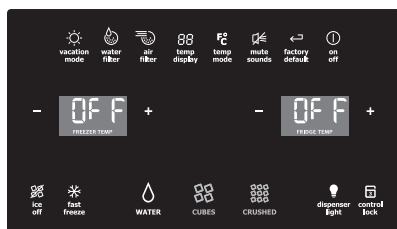

Alarms

Door Ajar	If the door has been left open for an extended period of time, an alarm will sound and the door ajar indicator will display on the center of the display. The alarm is turned off by closing the door. The alarm off key will blink to prompt the reset of any pending alarms. Press this key to reset any system alarms.
High Temp	In the event of a high temperature condition, the temperature display will blink and display HI. After 20 minutes, the high temp alert will be displayed and the alarm off icon will illuminate until pressed, acknowledging the alarm, at which time the highest temperature reached will be displayed and the refrigerator will resume normal operation. All other modes are turned off until the alarm is acknowledged.

Power Fail	In the event of a power failure, the power fail alert will be displayed and the alarm off key will blink until the alarm off icon is pressed, acknowledging the alarm. Other modes may be turned off until the alarm is acknowledged. When the power fail alert is turned off, the refrigerator will resume normal operation. The high temp alarm may also be illuminated until a safe operating range temperature has been reached.
------------	--

Wave-Touch™ / IQ-Touch™ Sabbath Mode

The Sabbath Mode is a feature that disables portions of the refrigerator and its controls for both Wave-Touch™ and IQ-Touch™, in accordance with observance of the weekly Sabbath and religious holidays within the Orthodox Jewish community.

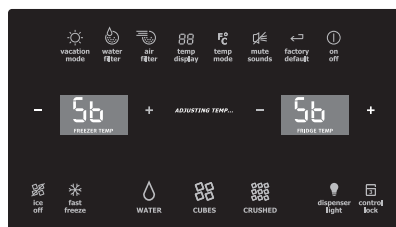



NOTE

While in Sabbath Mode, the Wave-Touch™ model will only illuminate the -/+ keys used to turn the Sabbath Mode Off.

Sabbath Mode is turned on and off by simultaneously pressing and holding both the outermost - and + indicators for five seconds for both the Wave-Touch™ and IQ-Touch™ modes. The display shows Sb while in Sabbath mode.

In the Sabbath Mode, the High Temp alarm is active for health reasons. For example, if the door is left ajar the High Temp alarm is activated. The refrigerator will function normally once the door is closed, without any violation of the Sabbath/Holidays. The High Temp alarm is permitted when cabinet temperature is outside the safe zone for 20 minutes. The alarm silences itself after 10 minutes while the High Temp icon stays lit until the Sabbath mode is exited.

For further assistance, guidelines for proper usage and a complete list of

models with the Sabbath feature, please visit the web at <http://www.star-k.org>.



NOTE

While in Sabbath Mode, neither the lights, dispenser, nor the control panel will work until Sabbath Mode is deactivated.

Refrigerator stays in Sabbath Mode after power failure recovery. It must be deactivated with the buttons on the control panel.



NOTE

Although you have entered the Sabbath Mode, the ice maker will complete the cycle it had already initiated. The ice cube compartment will remain cold and new ice cubes can be made with standard trays.

Sabbath Mode and the Perfect Temp™ Drawer

The Perfect Temp™ Drawer should be turned off for the Sabbath/Holidays. Before putting the refrigerator into the Sabbath mode, turn the Perfect Temp™

Drawer off by pressing the drawer on/off button. The display will show OFF and the drawer will turn off. Then enter the Sabbath mode function on the main refrigerator display. (See Wave-Touch/IQ-Touch Sabbath Mode section.) When in Sabbath mode, the display will not illuminate and the drawer will remain off. The drawer can still be used as a non-temp controlled drawer in this mode. When the refrigerator is taken out of Sabbath mode, the Perfect Temp™ Drawer will have to be turned back on.



NOTE

If the Perfect Temp™ Drawer is not turned off prior to putting the unit into Sabbath Mode, it will continue to adjust itself to maintain the set point even if the display does not illuminate to show that it is still on.

IQ-Touch™ (select models)

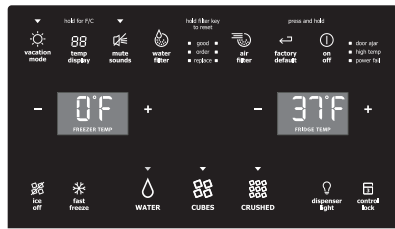

Your refrigerator is equipped with a glass touch control panel. It is only necessary to gently touch the glass. There are three dispenser modes:

- 1 Water
- 2 Ice Cubes
- 3 Crushed Ice

An indicator light will be illuminated above the active feature.

Touch the icon to activate the options below.

ice off
(Fresh Food
Ice Maker)

Press and hold for three seconds to turn the ice maker ON or OFF. The ice maker is OFF when the LED above the Ice Off icon is illuminated. If there is no indicator, then the ice maker is ON. Turning the ice maker OFF disables the ice dispensing feature. Neither CUBES nor CRUSHED will operate with the ice maker OFF.

fast freeze

Activates a faster rate for freezing food and increased ice production.



NOTE

Refer to Automatic Ice Maker-Freezer section for freezer ice maker controls.

dispenser light	On / Off
control lock	Press and hold for three seconds to activate and deactivate. This restricts undesired changes to the refrigerators settings and prevents use of the ice and water dispenser.
vacation mode	Conserves energy by increasing the time between automatic defrost. This feature is automatically activated during long periods between door openings. Vacation mode is manually activated when the indicator is lit.
water filter	Touch to display filter condition status. Press and hold for three seconds to reset after filter change.
air filter	Touch to display filter status. Press and hold for three seconds to reset after filter change.
temp display	Touch to toggle the freezer and fridge temp display on and off. Touch and hold temp display to toggle display from Fahrenheit to Celsius.
mute sounds	Tones emitted by each key press can be turned off based on user preference. The sounds are muted when the indicator is lit. Warning signals will stay active.
factory default	Resets all refrigerator settings such as temp, temp display, and ring tones to their factory default settings.
on off	Press and hold for three seconds to turn off the cooling system to clean the refrigerator. It also turns off the ice maker and all dispenser functions. The temperature display will read OFF.



IMPORTANT

Pressing the system on/off icon does not turn off power to your refrigerator. You must unplug the power cord from the wall outlet.



IMPORTANT

When the ice maker is turned off, the ice in the bucket should be transferred to the freezer or discarded to prevent it from melting.

Setting cooling temperatures

- 1 Touch the control panel to illuminate plus (+) and minus (-) indicators on either side of the temperatures displays.
- 2 Press the + or - indicator to adjust the temperature to the desired setting.

The temperature display will begin to blink with the first touch. The display will time out after a minute and returns to the basic display.

Alarms

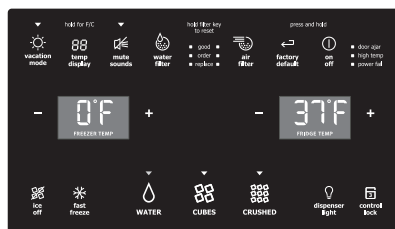

- Door Ajar** If the door has been left open for an extended period of time, an alarm will sound and the door ajar indicator will display on the right side of the control panel. The alarm is turned off by closing the door. The mute sounds key will blink to prompt the reset of any pending alarms. Press this key to reset any system alarms.
- High Temp** In the event of a high temperature condition, the temperature display will blink and display HI. After 20 minutes, the high temp alert will be displayed and the alarm off icon will illuminate until pressed, acknowledging the alarm, at which time the highest temperature reached will be displayed and the refrigerator will resume normal operation. All other modes are turned off until the alarm is acknowledged.
- Power Fail** In the event of a power failure, the power fail alert will be displayed and the temperature display will blink until the mute sounds icon is pressed, acknowledging the alarm. Other modes may be turned off until the alarm is acknowledged. The power fail alert is turned off and the refrigerator will resume normal operation. The high temp alarm may also be illuminated until a safe operating range temperature has been reached.

Priming the water supply system



CAUTION

For proper dispenser operation, recommended water supply pressure should fall between 30 psi and 100 psi. Excessive pressure may cause water filter to malfunction.

- 1 Begin filling the tank by pressing and holding a drinking glass against the water dispenser paddle.
- 2 Keep the glass in this position until water comes out of the dispenser. It may take about 1½ minutes.
- 3 Continue dispensing water for about three minutes to flush the system and plumbing connections of any impurities (stopping to empty the glass as necessary).



NOTE

The water dispenser has a built-in device that shuts off the water flow after three minutes of continuous use. To reset this shutoff device, simply release the dispenser paddle.

Ice maker operation & care

After the refrigerator is installed properly and has cooled for several hours, the ice maker can produce ice within 24 hours. The ice maker will fill the ice bin from the rear. You must dispense some ice to force the ice forward in the bin. This will allow the bin to fill completely.



IMPORTANT

Your ice maker is turned on at the factory so it can work as soon as you install your refrigerator. If you cannot connect a water supply, set the ice maker's On/Off icon to Off and turn off the water supply valve; otherwise, the ice maker's fill valve may make a loud chattering noise when it attempts to operate without water.

Turning the fresh food ice maker on and off

Ice production is controlled by the ice maker's On/Off icon on the control panel. Press and hold the Ice Off icon for three seconds to turn the ice maker ON or OFF. If there is no indicator, then the ice maker is ON.



IMPORTANT

Turning off the ice maker will result in existing ice melting in the bin.



IMPORTANT

Turning off the ice maker will disable the ice dispenser. You will still be able to dispense water.



NOTE

The ice maker also has a built-in plastic signal bale arm that automatically stops ice production when the ice bin is full. This signal arm should not be used to manually stop the ice maker.

Using the ice maker after installation

Before making ice for the first time, be sure to prime the water supply system. Air in new plumbing lines can result in two or three empty ice maker cycles. Furthermore, if the system is not flushed, the first ice cubes may be discolored or have an odd flavor.



IMPORTANT

On occasion, unusually small ice cubes may be noticed in the bucket or in dispensed ice. This could occur in normal operation of the ice maker. If you start seeing these more frequently, it may be an indication of low water pressure or the water filter needs to be replaced. As the water filter nears the end of its useful life and becomes clogged with particles, less water is delivered to the ice maker during each cycle. Remember, if it's been six months or longer since you last changed your water filter, replace the water filter with a new one. Poor quality household water may require the filter to be changed more frequently.

Ice maker/dispenser tips

- If your refrigerator is not connected to a water supply or the water supply is turned off, turn off the ice maker by holding the On/Off soft-touch icon for three seconds.
- The following sounds are normal when the ice maker is operating:
 - Motor running
 - Ice dropping into ice bin
 - Water valve opening or closing
 - Running water
- When dispensing ice, you will hear a snapping or clicking sound when the ice chute opens and closes.
- If you need a large quantity of ice at one time, it is best to get cubes directly from the ice bin.
- Ice cubes stored too long may develop an odd flavor. Empty the ice bin as explained below.
- When dispensing cubed ice, it is normal to have a small quantity of little pieces along with the whole cubes.

**CAUTION**

If the water supply to your refrigerator is softened, be sure the softener is properly maintained. Chemicals from a water softener can damage the ice maker.

Cleaning the ice maker

Clean the ice maker and ice bin at regular intervals, especially prior to vacation or moving.

- 1 Turn off the ice maker.
- 2 Remove the ice bin by pulling straight out.
- 3 Empty and carefully clean the ice bin with mild detergent. Do not use harsh or abrasive cleaners. Rinse with clear water.
- 4 Allow the ice bin to dry completely before replacing in the freezer.
- 5 Replace the ice bin. Turn the ice maker on.

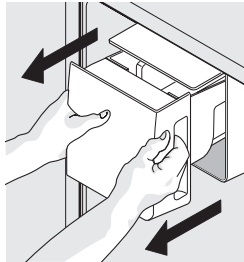
**Removing Ice Bin****Remove and empty the ice bin if:**

- An extended power failure (one hour or longer) causes ice cubes in the ice bin to melt and freeze together, jamming the dispenser mechanism.
- You do not use the ice dispenser frequently. Ice cubes will freeze together in the bin, jamming the dispenser mechanism.

Remove the ice bin and shake to loosen the cubes or clean as explained above.

**CAUTION**

NEVER use an ice pick or similar sharp instrument to break up the ice. This could damage the ice bin.

To loosen stuck ice, use warm water. Before replacing the ice bin, make sure it is completely dry.

**IMPORTANT**

When removing or replacing the ice bin, DO NOT rotate the auger in the ice bin. If the auger is accidentally rotated, you must realign the auger by turning it in 45 degree turns (see below) until the ice bin fits into place with the drive mechanism. If the auger is not properly aligned when replacing the ice bin, the refrigerator will not dispense ice. The fresh food door also may not close properly causing warm air to leak into the fresh food compartment.

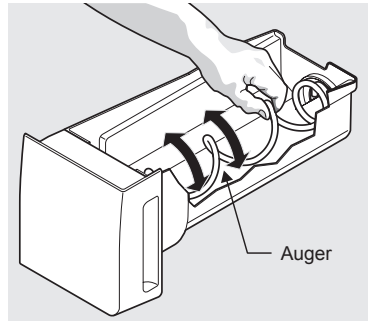
**Adjusting Ice Bin Auger****NOTE**

Most models allow for an additional freezer ice maker to be installed. Call your local dealer for more information.

Ice maker operation & care (select models)

After the refrigerator is installed properly, the ice maker can produce ice within 24 hours. It can completely fill an ice bin in about three days.

When using the ice maker for the first time and in order for the ice maker to work properly, it is necessary to clear air from water filter tubing. Once ice maker begins making ice, allow the bucket to fill completely, then discard the first TWO FULL buckets of ice. It will take at least two days to completely fill the bucket on regular ice making mode or 1½ days on fast ice mode.

The ice maker produces approximately four pounds of ice every 24 hours depending on usage conditions.



IMPORTANT

Your ice maker is turned on at the factory so it can work as soon as you install your refrigerator. If you cannot connect a water supply, lift the ice maker's wire signal arm to turn it off. Otherwise, the ice maker's fill valve may make a loud chattering noise when it attempts to operate without water.

Turning the ice maker on and off

Ice production is controlled by lifting/lowering the ice maker's wire signal arm. To gain access to the ice maker, pull the freezer drawer out. Lift the wire signal arm to turn the ice maker OFF and lower the wire signal arm to turn it ON.

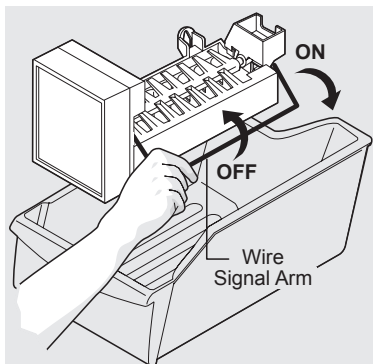

Ice maker tips

- If your refrigerator is not connected to a water supply or the water supply is turned off, turn off the ice maker by lifting wire signal arm.

- The following sounds are normal when the ice maker is operating:
 - Motor running
 - Ice dropping into ice bin
 - Water valve opening or closing
 - Running water
- Ice cubes stored too long may develop an odd flavor. Empty the ice bin as explained below.

Fast Ice Function

Your refrigerator is equipped with a "Smart" Fast Ice Function, that will, if activated at your user interface, allow an increase in ice production. You do not need to deactivate it, if not needed, your refrigerator will operate on normal conditions.



CAUTION

If the water supply to your refrigerator is softened, be sure the softener is properly maintained. Chemicals from a water softener can damage the ice maker.

Cleaning the ice maker

Clean the ice maker and ice bin at regular intervals, especially prior to vacation or moving.

- Turn off the ice maker.
- Remove the ice bin.
- Empty and carefully clean the ice bin with mild detergent. Do not use harsh or abrasive cleaners. Rinse with clean water.
- Allow the ice bin to dry completely before replacing in the freezer.
- Replace the ice bin. Turn the ice maker on.

Remove and empty the ice bin if:

- An extended power failure (one hour or longer) causes ice cubes in the ice bin to melt and freeze together.

Remove the ice bin and shake to loosen the cubes or clean as explained above.



CAUTION

NEVER use an ice pick or similar sharp instrument to break up the ice. This could damage the ice bin.

To loosen stuck ice, use warm water. Before replacing the ice bin, make sure it is completely dry.

24 Storage Features

Shelf features



CAUTION

To avoid personal injury or property damage, handle tempered glass shelves carefully. Shelves may break suddenly if nicked, scratched, or exposed to sudden temperature change. Allow the glass shelves to stabilize to room temperature before clearing. Do not wash in dishwasher.



NOTE

Features may vary according to model.

To change the position of a shelf:

- 1 Remove shelf from its locked position by pulling the slide mechanism toward you.

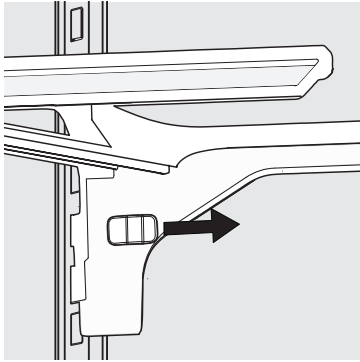

- 2 Lift the hanger directly upwards and pull toward you to remove it from the ladder.

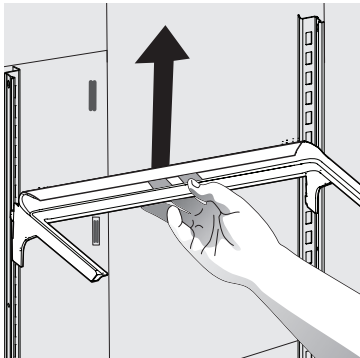

- 3 Place top hooks of the hanger into the desired slot, and lower straight down until lower hooks rest on the ladder.

- 4 Relock shelf by pushing the slide mechanism away from you.

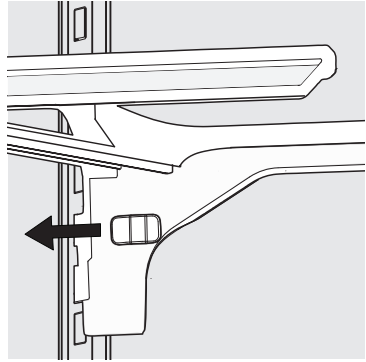

- 5 While holding shelf at a 45-degree angle with the gray handle facing you, push the shelf into the back of the hanger.

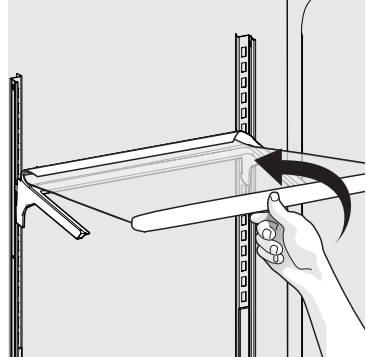

- 6 Gently set the shelf onto the hanger once the back is secured by the hanger.

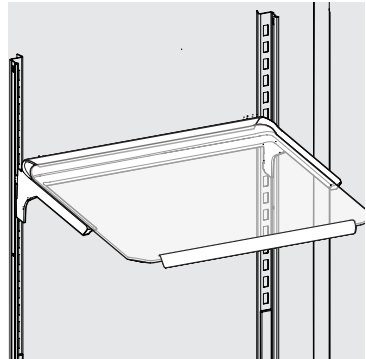

CAUTION

Shelves must be removed prior to moving the refrigerator.

Drawers

Your refrigerator includes a variety of storage drawers. These drawers are located in fixed positions at the bottom of the fresh food compartment.

Luxury-Glide™ Crispers

Crisper drawers are designed for storing fruits, vegetables, and other fresh produce. They feature a smooth-glide, ball-bearing system and soft-close functionality so as not to bruise your fruits and vegetables.

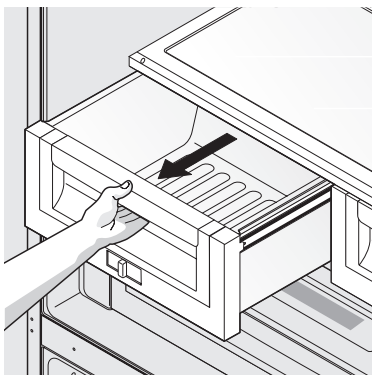

Opening Crisper Drawer

Crisper humidity control

Crisper drawers include a sliding control for adjusting the humidity inside the crisper. Leafy vegetables keep best when stored with the Humidity Control set on Higher Humidity. Fresh fruits keep best when stored with the Humidity Control set on Lower Humidity.

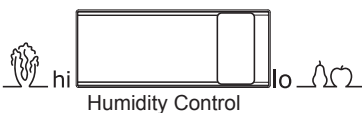

Humidity Control

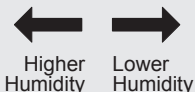

Adjusting Crisper Humidity
(varies by model)

To remove the Crisper Drawer for cleaning:

- 1 Pull the drawer out until it stops.
- 2 Lift the front slightly and remove the drawer.

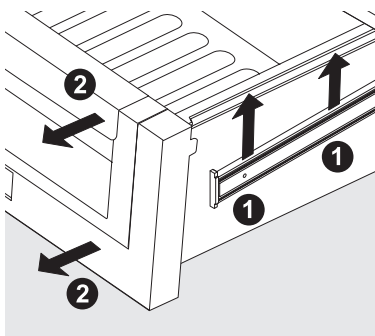

Removing Crisper Drawer

Special item mat (select models)

The innovative design of the special item mat allows you to store four bottles of wine or soft drink bottles, or any item that you want to prevent moving around.

Cool Zone Drawer (select models)

Some models are equipped with a drawer for short-term storage of bulk items. This drawer includes sliding controls for adjusting the humidity inside.

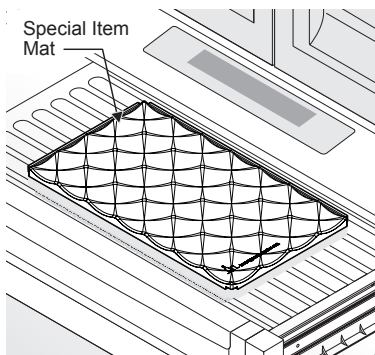

NOTE

Any meat to be kept longer than two days should be frozen. If you store fruits or vegetables in this drawer, set it to a higher humidity.

26 Storage Features

Perfect Temp™ Drawer (select models)



The Perfect Temp™ Drawer is designed to keep food items at a precise temperature whether cooler, warmer, or the same as the fresh food section of the refrigerator. This drawer features a smooth-glide, ball-bearing system and soft-close functionality so as not to bruise your fruits and vegetables. The thaw setting holds a temperature for thawing frozen foods for 12 hours. At the end of that time, it then switches to the snacks setting to store the thawed food.

To operate:

- 1 To turn on and off, press the drawer's On/Off button. The numeric display will show a temperature between 28° F and 42° F when on and OFF when off.
- 2 Press F/C if you prefer to display Fahrenheit (F), or Celsius (C).
- 3 Press either the up \wedge or down \vee scroll buttons to illuminate the desired item.
- 4 Once an option is selected, the drawer will adjust and maintain the temperature for the setting selected.
- 5 When turned off, the Perfect Temp™ Drawer functions as a standard meat pan. The Perfect Temp™ Drawer is best used for packaged food products. Leafy vegetables and unpackaged fruits are best kept in one of the crisper drawers.
- 6 The three favorite selections provide flexibility to set and store personal temperature selections. The temperature is adjusted up by pressing the + or – buttons. The drawer will store the selected temperature setting until it is changed.
- 7 The control buttons can be locked to prevent accidental changes by pressing the control lock button for three seconds. Deactivate by pressing for three seconds again.

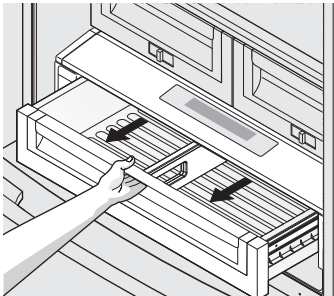

Opening the Drawer

IMPORTANT

DO NOT clean the display area of the Perfect Temp™ Drawer with abrasive or caustic cleaners. Wipe clean with a moist sponge.

CAUTION

The Perfect Temp™ Drawer and cover can be removed for cleaning but the control unit, attached to the right side of the fridge, cannot be removed. Do not immerse the Perfect Temp™ Drawer cover in water or put it in a dishwasher. Clean with a damp cloth or sponge.

To remove the Perfect Temp™ Drawer for cleaning:

- 1 Pull the drawer out until it stops.
- 2 Lift the front slightly and remove the drawer.

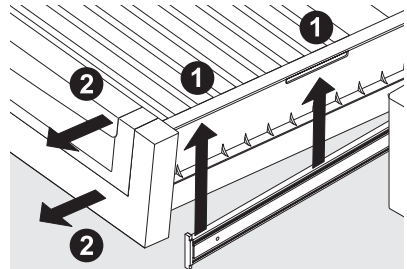

Removing the Drawer

NOTE

When the refrigerator is turned off by pressing the main Wave-Touch™ or IQ-Touch™ on/off button, the Perfect Temp™ Drawer will also be turned off. When the refrigerator is turned back on, the Perfect Temp™ Drawer will resume operations at the temp setting that was set before the refrigerator was turned off.

Doors

Storage bins

The doors to your fresh food compartment use a system of modular storage bins. All of these bins are removable for easy cleaning. Some of them have fixed positions, while others can be adjusted to your needs.

Door bins are ideal for storing jars, bottles, cans, and large drink containers. They also enable quick selection of frequently used items.

To change the position of an adjustable door bin:

- 1 Remove all food from bin.
- 2 Grip the bin firmly with both hands and lift it upward.
- 3 Remove the bin.
- 4 Place the bin just above desired position.
- 5 Lower the bin onto supports until locked in place.

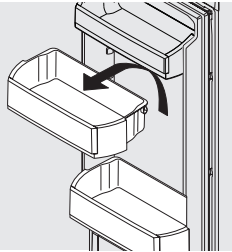

Adjustable Door Bin

Accessories (varies by model)

Tall bottle retainer

The tall bottle retainer keeps tall containers in the bin from falling forward when opening or closing the refrigerator door. To install, insert the ends of the retainer into the holes.

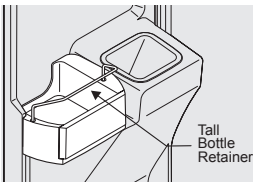

Tall Bottle Retainer

Tilt can bins

The can bins allow you to efficiently and securely store up to eight 12-ounce canned beverages.

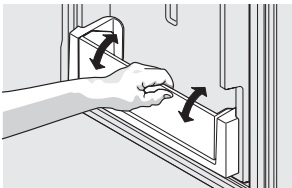

Tilt Can Bin

Freezer Features (varies by model)

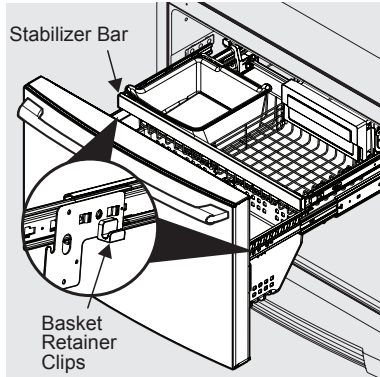

Freezer Baskets

To Remove Middle Basket

- 1 Remove all items from basket.
- 2 Remove basket by pulling basket out to its full extension and lift out.

To reinstall middle basket, position basket onto the retainer clips making sure the front of the basket rests in the retainer clips on the stabilizer bar.



NOTE

If basket is not resting on stabilizer bar retainer clips, the drawer will not close properly.

28 Storage Features

Removing Freezer Basket Instructions

- 1 Locate the basket clips in the rear corners of the basket and pull them out to remove.
- 2 Lift the basket up and remove.

Replacing Freezer Basket Instructions

- 1 Place freezer basket back inside the freezer drawer.
- 2 Replace clips by sliding them back into the slots.

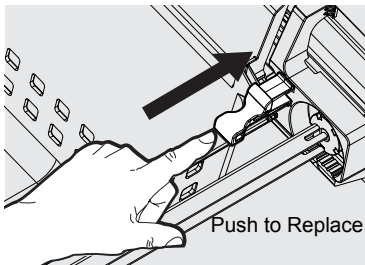
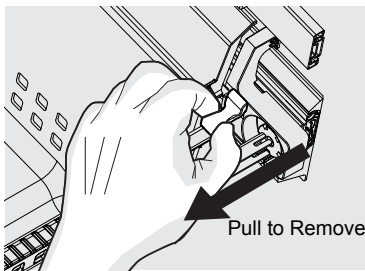
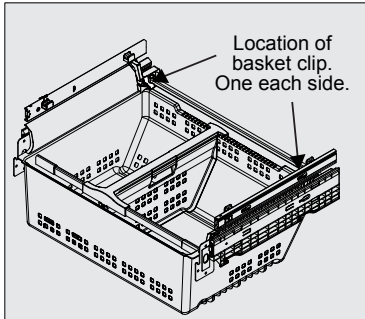

Soft Serve Bin

The soft serve bin in the upper right corner is designed to maintain temperatures a few degrees above the freezer temperature. This is perfect for storing items that need a softer texture in order to easily serve, items such as ice cream.

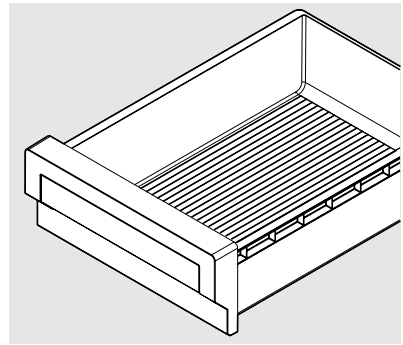

Dividers Removal

Lift up on the front of the middle divider and pull out.

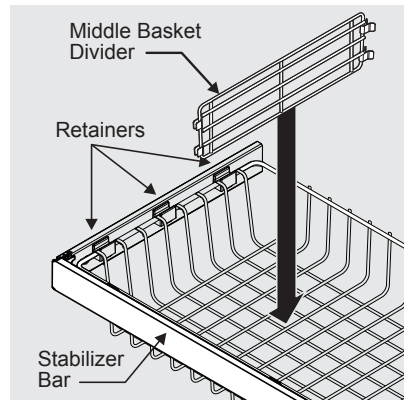

Wire Middle Basket Divider

Squeeze handle and lift up in the center of the divider to move it side-to-side. (The divider cannot be removed.)

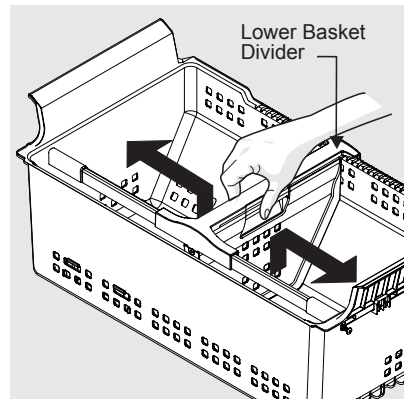

Plastic Lower Basket Divider

Ideas for storing foods

Fresh food storage

- Keep the fresh food compartment between 34° F and 40° F with an optimum temperature of 37° F.
- Avoid overcrowding the refrigerator shelves, which reduces air circulation and causes uneven cooling.

Fruits and vegetables

- Store fruits and vegetables in crisper drawers, where trapped moisture helps preserve food quality for longer time periods.
- Wash items and remove excess water.
- Wrap any items that have strong odors or high moisture content.

Meat

- Wrap raw meat and poultry separately and securely to prevent leaks and contamination of other foods or surfaces.
- Use the Cool Zone drawer or Perfect Temp™ drawer and set to meat/poultry setting for short-term storage. Any meat to be kept longer than two days should be frozen.

Frozen food storage

- Keep the freezer compartment at 0° F or lower.
- A freezer operates most efficiently when it is at least 2/3 full.

Packaging foods for freezing

- To minimize food dehydration and quality deterioration, use aluminum foil, freezer wrap, freezer bags, or airtight containers. Force as much air out of the packages as possible and seal them tightly. Trapped air can cause food to dry out, change color, and develop an off-flavor (freezer burn).
- Wrap fresh meats and poultry with suitable freezer wrap prior to freezing.
- Do not refreeze meat that has completely thawed.

Loading the freezer

- Prior to grocery shopping, activate fast freeze so that on your return you can ensure your newly purchased food designated for the freezer will be preserved as quickly as possible.

- Activating fast freeze also will help your freezer more efficiently maintain the selected temperature after placing new purchases with pre-existing frozen foods.
- Avoid adding too much warm food to the freezer at one time. This overloads the freezer, slows the rate of freezing, and can raise the temperature of frozen foods.
- Leave a space between packages, so cold air can circulate freely, allowing food to freeze as quickly as possible.

Ideas for saving energy

Installation

- Locate the refrigerator in the coolest part of the room, out of direct sunlight, and away from heating ducts or registers.
- Do not place the refrigerator next to heat-producing appliances such as a range, oven, or dishwasher. If this is not possible, a section of cabinetry or an added layer of insulation between the two appliances will help the refrigerator operate more efficiently.
- Level the refrigerator so that the doors close tightly.

Temperature settings

- Refer to the Controls section for procedures on temperature settings.

Food storage

- Avoid overcrowding the refrigerator or blocking cold air vents. Doing so causes the refrigerator to run longer and use more energy.
- Cover foods and wipe containers dry before placing them in the refrigerator. This cuts down on moisture build-up inside the unit.
- Organize the refrigerator to reduce door openings. Remove as many items as needed at one time and close the door as soon as possible.
- Do not place a hot container directly on a cold shelf. Remember, such an extreme temperature change may damage the glass.

30 Normal Operating Sounds

Understanding the sounds you may hear

Your new, high-efficiency refrigerator may introduce unfamiliar sounds. These sounds normally indicate your refrigerator is operating correctly. Some surfaces on floors, walls, and kitchen cabinets may make these sounds more noticeable.

The following is a list of major components in your refrigerator and the sounds they can cause:

- A Evaporator** Refrigerant through the evaporator may create a boiling or gurgling sound.
- B Evaporator fan** You may hear air being forced through the refrigerator by the evaporator fan.
- C Defrost heater** During defrost cycles, water dripping onto the defrost heater may cause a hissing or sizzling sound. After defrosting, a popping sound may occur.
- D Automatic ice maker** When ice has been produced, you will hear ice cubes falling into the ice bin. Ice maker fan, water valve activation, and refrigerant gas fluid may create sounds from its operation.
- E Electronic control & automatic defrost control** These parts can produce a snapping or clicking sound when turning the cooling system on and off.
- F Condenser fan** You may hear air being forced through the condenser.
- G Compressor** Modern, high-efficiency compressors run much faster than older models. The compressor may have a high-pitched hum or pulsating sound.
- H Water valve** Makes a buzzing sound each time it opens to fill the ice maker.
- I Drain pan** (not removable) You may hear water dripping into the drain pan during the defrost cycle.
- J Condenser** May create minimal sounds from forced air.
- K Motorized Perfect Temp™ drawer damper** May produce a light humming during operation.

- L Ice dispensing paddle** When dispensing ice, you will hear a snapping, clicking, or popping sound when the solenoid opens and closes the ice chute.
- M Motorized damper** May produce a light humming during operation.
- N Perfect Temp™ drawer fan** Turns off when door opens or **Perfect Temp™** drawer is turned off.

NOTE

Energy efficient foam in your refrigerator is not a sound insulator.

NOTE

During automatic defrost cycle, a red glow in the back wall vents of your freezer compartment is normal.

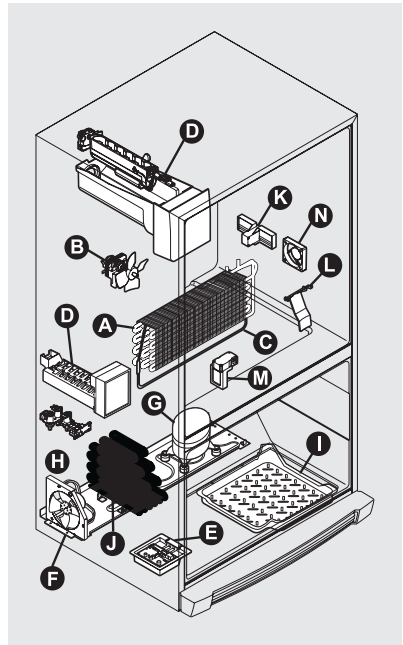

Your refrigerator is equipped with separate water and air filtering systems. The water filter system filters all dispensed drinking water, as well as the water used to produce ice. The air filter removes odors and impurities from the refrigerator compartment.



NOTE

The control panel includes controls to monitor the status of your water and air filters. See the Controls section for more information.

About your advanced water filter



The PureAdvantage™ NGFC 2000 ice and water filter system is tested and certified by NSF International to NSF/ANSI Standards 42 and 53 for the reduction of claims specified on the performance data sheet.

Do not use with water that is microbiologically unsafe or of unknown quality without adequate disinfection before or after the system. Systems certified for cyst reduction may be used on disinfected waters that may contain filterable cysts.

- Rated Capacity - 400 gallons for PureAdvantage™ ice and water filter
- Rated service flow - .5 gallons per minute
- Maximum Rated Pressure - 100 pounds per square inch
- Recommended Minimum Operating Pressure: 30 pounds per square inch
- Operating Temp.: Min. 33° F, Max. 100° F

Water filter

The water filter is located at the lower left side of the fresh food compartment.

Replacing your PureAdvantage™ water filter

In general, you should change the water filter every six months to ensure the highest possible water quality. The Water Filter Status light on the Touch Panel prompts you to replace the filter after a standard amount of water (400 gallons) has flowed through the system.

If your refrigerator has not been used for a period of time (during moving for example), change the filter before reinstalling the refrigerator.

It is not necessary to turn the water supply off to change the filter. Be ready to wipe up any small amounts of water released during the filter replacement.

- 1 Turn Off the ice maker on the control panel.
- 2 Push the filter release button above the cartridge to disconnect it.
- 3 Slide the old water filter cartridge straight out of the housing and discard it.

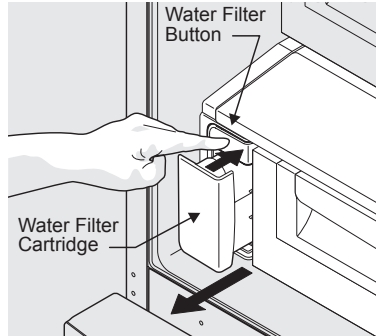

Push Water Filter Button

- 4 Unpack the new filter cartridge and remove the two protective caps covering the inlet and exit of the filter. Slide the filter gently into the housing until it stops against the snap-in connector at the back of the housing.

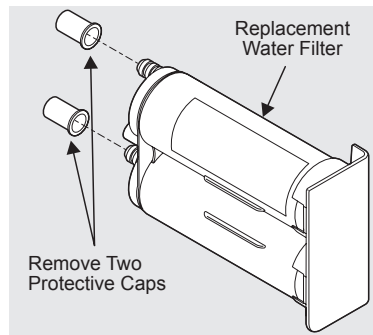

32 Changing The Water and Air Filters

- 5 Push firmly until the cartridge snaps into place (you should hear two clicks). When fully engaged, the front of the filter cartridge should be flush with the filter release button.

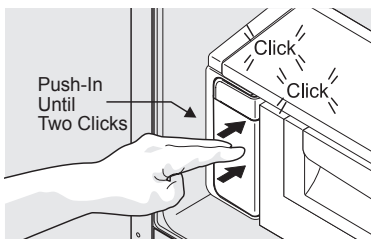

Reinstall Water Filter

- 6 Turn On the ice maker at the control panel.
- 7 Turn a drinking glass against the water dispenser while checking for any leaks at the filter housing. Spurts and sputters may occur as the system purges air out of the dispenser system.
- 8 Prime the water supply system as described previously.
- 9 Press and hold the Filter Status button on the control panel for three seconds. When the display changes from Replace to Good, the status has been reset.

Air filter

The air filter is located under the utility bin and/or on the inside of the left door above the ice maker chute.

Replacing your PureAdvantage™ air filter

To ensure optimal filtering of refrigerator odors, you should change the air filter every six months (the filter status light on the Touch Panel prompts you to replace the filter after six months).

- 1 Open the air filter door.
- 2 Remove the old filter and discard it.
- 3 Unpack the new filter and slide it into the housing.
- 4 To close the air filter door, push the top and bottom to lock the door closed.

- 5 Press and hold the Air Filter Reset button on the control panel for three seconds. When the display changes from Replace to Good, the status has been reset.
- 6 The Air Filter Reset will turn itself off after a few seconds.

Filter located under the utility bin

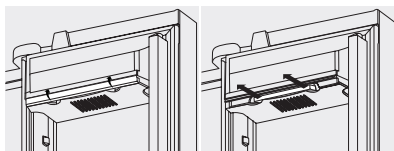

Ordering replacement filters

Order new filters by calling 877-808-4195, online at www.electroluxappliances.com, or through the dealer where you bought your refrigerator. You may want to consider ordering extra filters when you first install your refrigerator.

Water Filter

FC-300 PureAdvantage™ Replacement Cartridge #EWF01

Air Filter

Replacement cartridge, part #EAFCBF

Protecting your investment

Keeping your refrigerator clean maintains its appearance and prevents odor build-up. Wipe up any spills immediately and clean the freezer and fresh food compartments at least twice a year.



NOTE

Do not use abrasive cleaners such as window sprays, scouring cleansers, flammable fluids, cleaning waxes, concentrated detergents, bleaches, or cleansers containing petroleum products on plastic parts, interior doors, gaskets, or cabinet liners. Do not use paper towels, scouring pads, or other abrasive cleaning materials.

- Never use metallic scouring pads, brushes, abrasive cleaners, or strong alkaline solutions on any surface.
- Never use CHLORIDE or cleaners with bleach to clean stainless steel.
- Do not wash any removable parts in a dishwasher.
- Always unplug the electrical power cord from the wall outlet before cleaning.



NOTE

If you set your temperature controls to turn off cooling, power to lights and other electrical components will continue until you unplug the power cord from the wall outlet.

- Remove adhesive labels by hand. Do not use razor blades or other sharp instruments which can scratch the appliance surface.
- Do not remove the serial plate. Removal of your serial plate voids your warranty.
- Before moving your refrigerator, raise the anti-tip brackets so the rollers will work correctly. This will prevent the floor from being damaged.



CAUTION

- **Pull the refrigerator straight out to move it. Shifting it from side to side may damage flooring. Be careful not to move the refrigerator beyond the plumbing connections.**
- **Damp objects stick to cold metal surfaces. Do not touch refrigerated surfaces with wet or damp hands.**



IMPORTANT

If you store or move your refrigerator in freezing temperatures, be sure to completely drain the water supply system. Failure to do so could result in water leaks when the refrigerator is put back into service. Contact a service representative to perform this operation.

Refer to the guide on the next page for details on caring and cleaning specific areas of your refrigerator.

34 Care and Cleaning

Care and cleaning tips

Part	Cleaning Agents	Tips and Precautions
Interior & Door Liners	<ul style="list-style-type: none">• Soap and water• Baking soda and water	<ul style="list-style-type: none">• Use two tablespoons of baking soda in one quart of warm water.• Be sure to wring excess water out of sponge or cloth before cleaning around controls, light bulb or any electrical part.
Door Gaskets	<ul style="list-style-type: none">• Soap and water	<ul style="list-style-type: none">• Wipe gaskets with a clean soft cloth.
Drawers & Bins	<ul style="list-style-type: none">• Soap and water	<ul style="list-style-type: none">• Use a soft cloth to clean drawer runners and tracks.• Do not wash any removable items (bins, drawers, etc.) in dishwasher.
Glass Shelves	<ul style="list-style-type: none">• Soap and water• Glass cleaner• Mild liquid sprays	<ul style="list-style-type: none">• Allow glass to warm to room temperature before immersing in warm water.
Toe Grille	<ul style="list-style-type: none">• Soap and water• Mild liquid sprays• Vacuum	<ul style="list-style-type: none">• Remove toe grille (see Installation Instructions).• Vacuum both sides and wipe with sudsy cloth or sponge. Rinse and dry.
Exterior & Handles	<ul style="list-style-type: none">• Soap and water• Non abrasive glass cleaner	<ul style="list-style-type: none">• Do not use commercial household cleaners containing ammonia, bleach or alcohol to clean handles.• Use a soft cloth to clean smooth handles.• Do not use a dry cloth to clean smooth doors.
Exterior & Handles (Stainless Steel Models Only)	<ul style="list-style-type: none">• Soap and water• Stainless steel cleaners	<ul style="list-style-type: none">• Never use CHLORIDE or cleaners with bleach to clean stainless steel.• Clean stainless steel front and handles with non-abrasive soapy water and a dishcloth. Rinse with clean water and a soft cloth.• Use a non-abrasive stainless steel cleaner. These cleaners can be purchased at most home improvement or major department stores. Always follow manufacturer's instruction. Do not use household cleaners containing ammonia or bleach.• NOTE: Always clean, wipe and dry with grain to prevent scratching.• Wash the rest of the cabinet with warm water and mild liquid detergent. Rinse well and wipe dry with a clean soft cloth.

Vacation and moving tips

Occasion	Tips
Short Vacations	<ul style="list-style-type: none">• Leave refrigerator operating during vacations of three weeks or less.• Use all perishable items from refrigerator compartment.• Turn automatic ice maker off and empty ice bucket, even if you will only be gone a few days.
Long Vacations	<ul style="list-style-type: none">• Remove all food and ice if you will be gone one month or more.• Turn the cooling system off (see Controls section for location of On/Off button) and disconnect power cord.• Turn water supply valve to closed position.• Clean interior thoroughly.• Leave both doors open to prevent odors and mold build-up. Block doors open if necessary.
Moving	<ul style="list-style-type: none">• Remove all food and ice.• If using a handcart, load from the side.• Adjust rollers all the way up to protect them during sliding or moving.• Pad cabinet to avoid scratching surface.

Ice Chute Extension

The ice chute extension is designed to better direct ice flow into containers.

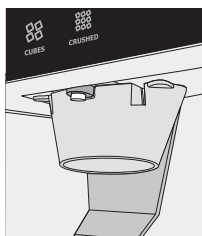

Removing the Ice Chute Extension For Cleaning

- 1 Turn the refrigerator off using the button on the control panel (refer to Owner's Manual).
- 2 Press inward firmly on the front of the chute and pull down.
- 3 Turn your refrigerator back on.

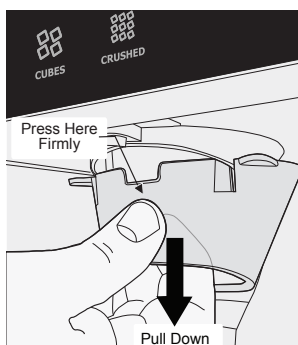

Installing the Ice Chute Extension

- 1 Turn the refrigerator off using the button on the control panel (refer to Owner's Manual).
- 2 Align the extension with the ice chute so that the snap clips are just inside the front edge of the chute.
- 3 Push upward until the extension snaps into place.
- 4 Turn your refrigerator back on.

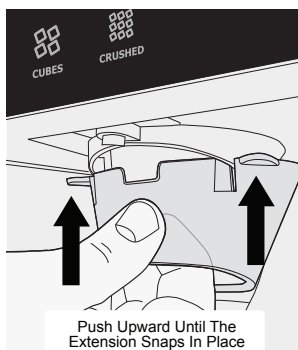

Replacing LED Lights

Both the freezer and fresh food compartments of your refrigerator include LED lights. Always use Electrolux parts for replacement.

To replace LED Lights:

- 1 Unplug your refrigerator's power cord.
- 2 Remove light cover by pushing up and out.
- 3 Hold the LED cover with one hand and pull the connector with the other hand while pressing the connector latch.
- 4 Replace LED light and snap in place assuring the light is facing in toward the unit (inside fresh food and freezer).

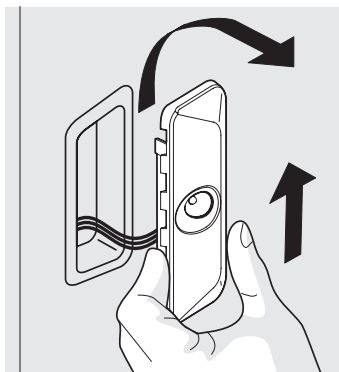

LED Light Removal

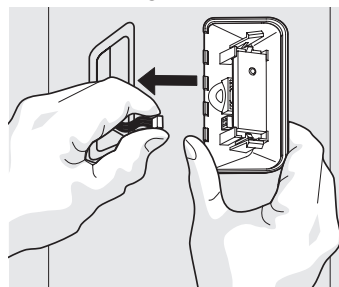

LED Light Harness Removal



NOTE

LED lights are in series so if one is bad or unplugged, several lights may not light up.

Ordering Replacement LED Lights

Order new LEDs by calling 877-808-4195, online at www.electroluxappliances.com, or through the dealer where you bought the refrigerator. Here is the product number to request when ordering:

LED Light, Part #241891102

36 Solutions to Common Problems

Before you call...

If you experience a problem with your refrigerator or notice a product behavior or condition that you do not understand, you can usually avoid a call to your service representative by referring to this section for an answer. Beginning with the following table, this information includes common concerns, causes, and suggested solutions.

Concern	Potential Cause	Common Solution
Automatic Ice Maker		
Ice maker is not making any ice.	<ul style="list-style-type: none"> Ice maker is turned off. Refrigerator is not connected to water line or water valve is not open. The water supply line is kinked. The water filter is not seated properly. The water filter may be clogged with foreign material. Saddle valve on cold water pipe is clogged or restricted by foreign material. 	<ul style="list-style-type: none"> Turn on ice maker. For the fresh food ice maker, press and hold the Ice Off button for four seconds until the indicator turns off. For the freezer ice maker, lower the wire signal arm. Connect the unit to the household water supply and ensure the supply valve is open. Ensure that the supply line does not kink when the refrigerator is pushed into place against the wall. Remove and re-install the water filter. Be sure to push the filter firmly so that you hear it lock solidly into position. If water dispenses slowly or not at all, or if the filter is six months old or older, it should be replaced. Turn off household water line valve. Remove valve. Ensure that valve is not a self-piercing saddle valve. Clean valve. Replace valve if necessary.
Ice maker is not making enough ice.	<ul style="list-style-type: none"> Ice maker is producing less ice than you expect. The water filter may be clogged with foreign material. The water supply line is kinked. Saddle valve on cold water pipe is clogged or restricted by foreign material. 	<ul style="list-style-type: none"> The fresh food and freezer ice makers will each produce approximately 2.5 pounds of ice every 24 hours depending on usage conditions. If water dispenses slower than normal, or if the filter is six months old or older, it should be replaced. Ensure that the supply line does not kink when the refrigerator is pushed into place against the wall. Turn off household water line valve. Remove valve. Ensure that valve is not a self-piercing saddle valve. Clean valve. Replace valve if necessary.
Freezer ice maker will not stop making ice.	<ul style="list-style-type: none"> Ice maker wire signal arm is being held down by some package in the freezer that has fallen against the ice maker. 	<ul style="list-style-type: none"> Move the item and release wire signal arm. Remove any ice cubes that may have frozen together over the wire signal arm.
Ice cubes are freezing together.	<ul style="list-style-type: none"> Ice cubes are not being used frequently enough. Ice cubes are hollow (shells of ice with water inside). The hollow cubes break open in the bin and leak their water onto existing ice, which causes it to freeze together. 	<ul style="list-style-type: none"> Remove ice container and discard ice. The ice maker will produce fresh supply. Ice should be used at least twice weekly to keep the cubes separated. This generally occurs when the ice maker does not get enough water. This is usually the result of a clogged water filter. Replace the water filter.

Concern	Potential Cause	Common Solution
Ice Dispenser		
Dispenser will not dispense ice.	<ul style="list-style-type: none"> Water supply is not connected. Ice storage bin is empty. Household water line valve is not open. Fresh Food door is not closed. Ice dispensing paddle has been held in for more than four to five minutes. 	<ul style="list-style-type: none"> Connect water supply (see Connecting The Water Supply section). Ensure ice maker is turned on. When the first supply of ice is dropped into the bin, the dispenser should operate. Open household water line valve. Allow sufficient time for the ice to be made. When ice is made, the dispenser should operate. Ensure Fresh Food door is closed. (See Problem Section, Opening/Closing of Doors/Drawers) Motor is overloaded. Motor overload protector will reset in approximately three minutes. Ice can then be dispensed.
Ice dispenser is jammed.	<ul style="list-style-type: none"> Ice has melted and frozen around auger due to infrequent use, temperature fluctuations, and/or power outages. Ice cubes are frozen together. Ice cubes are smaller than normal. 	<ul style="list-style-type: none"> Remove ice bin, thaw, and empty the contents. Clean bin, wipe dry, and replace in proper position. When new ice is made, dispenser should operate. Use the dispenser often so that cubes do not freeze together. The ice & water filter cartridge could be clogged. Replace the filter cartridge. Dispensing system operates best at 30-100 psi water pressure. Well water pressures should fall within this range.
Light Is Not On		
Light is not on.	<ul style="list-style-type: none"> Light bulb is burned out or LED light is damaged. No electric current is reaching refrigerator. Control system has disabled lights because one or both doors were left open too long. 	<ul style="list-style-type: none"> See Replacing Light Bulbs or LED lights in Care and Cleaning section. See Problem section, Running Your Refrigerator. Close and reopen door(s) to enable lights.
Odors In Refrigerator		
Interior is dirty. Odors.	<ul style="list-style-type: none"> Interior needs to be cleaned. Food with strong odors is stored in refrigerator. 	<ul style="list-style-type: none"> See Care & Cleaning Tips. Cover food tightly. Turn on air filtration system. Air filter may need to be changed more frequently if foods with strong odors are routinely stored in refrigerator.
Opening/Closing Of Doors/Drawers		
Door(s) will not close.	<ul style="list-style-type: none"> Refrigerator is not level. It rocks on the floor when moved slightly. 	<ul style="list-style-type: none"> Ensure floor is level and solid, and can adequately support the refrigerator. Contact a carpenter to correct a sagging or sloping floor.
Drawers are difficult to move.	<ul style="list-style-type: none"> Food is touching shelf on top of drawer. Drawer is overloaded 	<ul style="list-style-type: none"> Keep less food in drawer. Remove or redistribute food.

38 Solutions to Common Problems

Concern	Potential Cause	Common Solution
Running Your Refrigerator		
Compressor does not run.	<ul style="list-style-type: none"> • Cooling system is turned Off. • Refrigerator is in defrost cycle. • Plug at wall outlet is disconnected. • House fuse is blown or a tripped circuit breaker. • Power outage. • Electronic control system keeps the refrigerator at a constant temperature. 	<ul style="list-style-type: none"> • Turn cooling system On. See Controls Section for location of cooling system On/Off button. • This is normal for a fully automatic defrost refrigerator. The defrost cycle occurs periodically, lasting about 30 minutes. • Ensure plug is tightly pushed into outlet. • Check/replace fuse with a 15 amp time-delay fuse. Reset circuit breaker. • Check house lights. Call local Electric Company. • This is normal. Refrigerator goes on and off to keep temperature constant.
Refrigerator runs too much or too long.	<ul style="list-style-type: none"> • Room or outside weather is hot. • Refrigerator has recently been disconnected for a period of time. • Automatic ice maker is operating. • Doors are opened too frequently or too long. • Refrigerator/freezer door may be slightly open. • Freezer control is set too cold (control found in fresh food section). • Fresh food/freezer gasket is dirty, worn, cracked, or poorly fitted. • This model is provided with a high-efficiency, variable-speed compressor. 	<ul style="list-style-type: none"> • It's normal for the refrigerator to work longer under these conditions. • It takes 8-12 hours for the refrigerator to cool down completely. • Ice maker operation causes refrigerator to run slightly more. • Warm air entering the refrigerator causes it to run more. Open doors less often. • Ensure refrigerator is level. Keep food and containers from blocking door. See Problem section, Opening/Closing of Doors/Drawers. • Set freezer control to warmer setting until refrigerator temperature is satisfactory. Allow 24 hours for temperature to stabilize. • Clean or change gasket. Leaks in door seal will cause refrigerator to run longer in order to maintain desired temperatures. • It is normal for the compressor to run for long periods of time.
Digital temperature displays are flashing.	<ul style="list-style-type: none"> • Electronic control system has detected a performance problem. 	<ul style="list-style-type: none"> • Call your Electrolux service representative, who can interpret any messages or number codes flashing on the digital displays.

Concern	Potential Cause	Common Solution
Temperatures Are Too Cold		
Freezer temperature too cold. Refrigerator temperature is satisfactory.	<ul style="list-style-type: none"> Freezer control is set too cold. Ice maker is on. 	<ul style="list-style-type: none"> Set freezer control to a warmer setting. Allow 24 hours for temperature to stabilize. It is normal for the freezer compartment to over cool while automatic ice maker is on.
Refrigerator temperature too cold. Freezer temperature is satisfactory.	<ul style="list-style-type: none"> Refrigerator control is set too cold. 	<ul style="list-style-type: none"> Set refrigerator control to a warmer setting. Allow 24 hours for temperature to stabilize.
Food stored in drawers freezes.	<ul style="list-style-type: none"> Refrigerator control is set too cold. 	<ul style="list-style-type: none"> See solution above.
Food stored in Meat Keeper freezes (select models).	<ul style="list-style-type: none"> Meat Keeper temperature control is set too cold. 	<ul style="list-style-type: none"> Adjust Meat Keeper temperature control to a warmer setting. Meat should be stored at a temperature just below the freezing point for maximum fresh storage time. It is normal for ice crystals to form due to the moisture content of meat.
Temperatures Are Too Warm		
Freezer/ Refrigerator temperature is too warm.	<ul style="list-style-type: none"> Doors are opened too frequently or too long. Door is slightly open. 	<ul style="list-style-type: none"> Warm air enters the refrigerator whenever the door is opened. Open the door less often. See Problem section, Opening/ Closing of Doors/Drawers.
Freezer temperature is too warm. Refrigerator temperature is satisfactory.	<ul style="list-style-type: none"> Freezer control is set too warm. 	<ul style="list-style-type: none"> Set freezer control to a colder setting. Allow 24 hours for temperature to stabilize.
Refrigerator temperature is too warm. Freezer temperature is satisfactory.	<ul style="list-style-type: none"> Refrigerator control is set too warm. 	<ul style="list-style-type: none"> Set refrigerator control to a colder setting. Allow 24 hours for temperature to stabilize.
Temperature in the Cool Zone Drawer™ or Perfect Temp™ Drawer is too warm (select models).	<ul style="list-style-type: none"> Temperature control is set too warm. 	<ul style="list-style-type: none"> Adjust temperature control to a colder setting.

Concern	Potential Cause	Common Solution
Water Dispenser		
Dispenser will not dispense water.	<ul style="list-style-type: none"> Water supply is not connected. Household water line valve is not open. Ice & water filter cartridge is clogged. 	<ul style="list-style-type: none"> Connect water supply (see Connecting The Water Supply section). Open household water line valve. See Problem section Ice Maker Is Not Making Ice. Replace filter cartridge being sure to remove protective caps.
Water has an odd taste and/or odor.	<ul style="list-style-type: none"> Water has been in the tank for a period of time. Unit not properly connected to cold water line. Tubing used in the household water supply and installation may affect water taste and odor. Water has a high mineral content. 	<ul style="list-style-type: none"> Draw and discard 10-12 glasses of water to freshen the supply and completely rinse out the tank. Connect unit to cold water line that supplies water to the kitchen faucet. For best results, use copper tubing for water connections. Contact water treatment plant for help in checking water supply source.
Water pressure is extremely low.	<ul style="list-style-type: none"> Cut-off and cut-on pressures are too low (well systems only). Reverse osmosis system is in regenerative phase. 	<ul style="list-style-type: none"> Have someone turn up the cut-off and cut-on pressure on the water pump system (well systems only). It is normal for a reverse osmosis system to be below 20 psi during the regenerative phase.
Water/Moisture/Frost Inside Refrigerator		
Moisture collects on inside of refrigerator walls.	<ul style="list-style-type: none"> Weather is hot and humid. Door is slightly open. Door is opened too often or too long. Open containers. 	<ul style="list-style-type: none"> The rate of frost buildup and internal sweating increases. See Problem section, Opening/Closing of Doors/Drawers. Open door less often to allow internal temperature to stabilize. Keep containers covered.
Water collects on bottom side of drawer cover.	<ul style="list-style-type: none"> Vegetables contain and give off moisture. 	<ul style="list-style-type: none"> Moisture on the bottom side of the cover is not unusual. Move humidity control (select models) to lower setting.
Moisture collects in bottom of drawer.	<ul style="list-style-type: none"> Washed vegetables and fruit drain while in the drawer. Fruits and vegetables are kept past their prime. 	<ul style="list-style-type: none"> Dry items before putting them in the drawer. Water collecting in bottom of drawer is normal. Routinely clean out old fruits and vegetables especially if they begin to break down.
Moisture collects on outside of refrigerator or between doors.	<ul style="list-style-type: none"> Weather is humid. Door is slightly open, causing cold air from inside refrigerator to meet warm air from outside. 	<ul style="list-style-type: none"> This is normal in humid weather. When humidity is lower, the moisture should disappear. See Problem section, Opening/Closing of Doors/Drawers.

Major Appliance Warranty Information

Your appliance is covered by a one year limited warranty. For one year from your original date of purchase, Electrolux will repair or replace any parts of this appliance that prove to be defective in materials or workmanship when such appliance is installed, used, and maintained in accordance with the provided instructions. In addition, the cabinet liner and sealed refrigeration system (compressor, condenser, evaporator, dryer or tubing) of your appliance is covered by a two through five year limited warranty. During the 2nd through 5th years from your original date of purchase, Electrolux will repair or replace any parts in the cabinet liner and sealed refrigeration system which prove to be defective in materials or workmanship when such appliance is installed, used, and maintained in accordance with the provided instructions.

Exclusions

This warranty does not cover the following:

1. Products with original serial numbers that have been removed, altered or cannot be readily determined.
2. Product that has been transferred from its original owner to another party or removed outside the USA or Canada.
3. Rust on the interior or exterior of the unit.
4. Products purchased "as-is" are not covered by this warranty.
5. Food loss due to any refrigerator or freezer failures.
6. Products used in a commercial setting.
7. Service calls which do not involve malfunction or defects in materials or workmanship, or for appliances not in ordinary household use or used other than in accordance with the provided instructions.
8. Service calls to correct the installation of your appliance or to instruct you how to use your appliance.
9. Expenses for making the appliance accessible for servicing, such as removal of trim, cupboards, shelves, etc., which are not a part of the appliance when it is shipped from the factory.
10. Service calls to repair or replace appliance light bulbs, air filters, water filters, other consumables, or knobs, handles, or other cosmetic parts.
11. Pickup and delivery costs; your appliance is designed to be repaired in the home.
12. Surcharges including, but not limited to, any after hour, weekend, or holiday service calls, tolls, ferry trip charges, or mileage expense for service calls to remote areas, including the state of Alaska.
13. Damages to the finish of appliance or home incurred during transportation or installation, including but not limited to floors, cabinets, walls, etc.
14. Damages caused by: services performed by unauthorized service companies; use of parts other than genuine Electrolux parts or parts obtained from persons other than authorized service companies; or external causes such as abuse, misuse, inadequate power supply, accidents, fires, or acts of God.

DISCLAIMER OF IMPLIED WARRANTIES; LIMITATION OF REMEDIES

CUSTOMER'S SOLE AND EXCLUSIVE REMEDY UNDER THIS LIMITED WARRANTY SHALL BE REPAIR OR REPLACEMENT AS PROVIDED HEREIN. CLAIMS BASED ON IMPLIED WARRANTIES, INCLUDING WARRANTIES OF MERCHANTABILITY OR FITNESS FOR A PARTICULAR PURPOSE, ARE LIMITED TO ONE YEAR OR THE SHORTEST PERIOD ALLOWED BY LAW, BUT NOT LESS THAN ONE YEAR. ELECTROLUX SHALL NOT BE LIABLE FOR CONSEQUENTIAL OR INCIDENTAL DAMAGES SUCH AS PROPERTY DAMAGE AND INCIDENTAL EXPENSES RESULTING FROM ANY BREACH OF THIS WRITTEN LIMITED WARRANTY OR ANY IMPLIED WARRANTY. SOME STATES AND PROVINCES DO NOT ALLOW THE EXCLUSION OR LIMITATION OF INCIDENTAL OR CONSEQUENTIAL DAMAGES, OR LIMITATIONS ON THE DURATION OF IMPLIED WARRANTIES, SO THESE LIMITATIONS OR EXCLUSIONS MAY NOT APPLY TO YOU. THIS WRITTEN WARRANTY GIVES YOU SPECIFIC LEGAL RIGHTS. YOU MAY ALSO HAVE OTHER RIGHTS THAT VARY FROM STATE TO STATE.

If You Need Service

Keep your receipt, delivery slip, or some other appropriate payment record to establish the warranty period should service be required. If service is performed, it is in your best interest to obtain and keep all receipts. Service under this warranty must be obtained by contacting Electrolux at the addresses or phone numbers below.

This warranty only applies in the USA, Puerto Rico and Canada. In the USA and Puerto Rico, your appliance is warranted by Electrolux Major Appliances North America, a division of Electrolux Home Products, Inc. In Canada, your appliance is warranted by Electrolux Canada Corp. Electrolux authorizes no person to change or add to any obligations under this warranty. Obligations for service and parts under this warranty must be performed by Electrolux or an authorized service company. Product features or specifications as described or illustrated are subject to change without notice.

USA
1-877-435-3287
Electrolux Major Appliances North America
10200 David Taylor Drive
Charlotte, NC 28262

Canada
1-800-265-8352
Electrolux Canada Corp.
5855 Terry Fox Way
Mississauga, Ontario,
Canada L5V 3E4