



LG

Life's Good

ENGLISH

ESPAÑOL

OWNER'S MANUAL BOTTOM FREEZER REFRIGERATOR

Please read this manual carefully before operating your set and retain it for future reference.

MANUAL DE USUARIO REFRIGERADOR CON CONGELADOR INFERIOR

Lea detenidamente este manual antes de empezar a utilizar el refrigerador y guárdelo como referencia para el futuro.

Model Name/Nombre de Modelo **=color number/número de color

LFC20770**

LFC20786**

GM-B208J*CP

GM-B209F*

WARRANTY

LG ELECTRONICS U.S.A., INC. LG REFRIGERATOR LIMITED WARRANTY - U.S.A.

Should your LG Refrigerator ("Product") fail due to a defect in materials or workmanship under normal home use, during the warranty period set forth below, LG will at its option repair or replace the product. This limited warranty is valid only to the original retail purchaser of the product and applies only when purchased and used within the United States including U.S. Territories. Proof of original retail purchase is required to obtain warranty service under this limited warranty.

WARRANTY PERIOD		
Refrigerator/Freezer	Sealed System (Compressor, Condenser, and Evaporator only)	
One (1) year from the date of original retail purchase	One (1) year from the date of original retail purchase	Seven (7) years from the date of original retail purchase
Parts and Labor (internal/functional parts only)	Parts and Labor	Parts only (Consumer will be charged for labor).

Noises associated with normal operation and failure to follow instructions found in the use and care and installation guides or operating the unit in an unsuitable environment will not be covered under this warranty.

- ▶ Replacement products and parts are warranted for the remaining portion of the original warranty period or ninety (90) days, whichever is greater.

- ▶ Replacement products and parts may be new or remanufactured.

THIS WARRANTY IS IN LIEU OF ANY OTHER WARRANTY, EXPRESS OR IMPLIED, INCLUDING WITHOUT LIMITATION, ANY WARRANTY OF MERCHANTABILITY OR FITNESS FOR A PARTICULAR PURPOSE. TO THE EXTENT ANY IMPLIED WARRANTY IS REQUIRED BY LAW, IT IS LIMITED IN DURATION TO THE EXPRESS WARRANTY PERIOD ABOVE. NEITHER THE MANUFACTURER NOR ITS U.S. DISTRIBUTOR SHALL BE LIABLE FOR ANY INCIDENTAL, CONSEQUENTIAL, INDIRECT, SPECIAL, OR PUNITIVE DAMAGES OF ANY NATURE, INCLUDING WITHOUT LIMITATION, LOST REVENUES OR PROFITS, OR ANY OTHER DAMAGE WHETHER BASED IN CONTRACT, TORT, OR OTHERWISE. Some states do not allow the exclusion or limitation of incidental or consequential damages or limitations on how long an implied warranty lasts, so the above exclusion or limitation may not apply to you. This warranty gives you specific legal rights and you may also have other rights that vary from state to state.

THIS LIMITED WARRANTY DOES NOT COVER:

1. Service trips to deliver, pick up, install, or repair the product; instruct the customer on operation of the product; repair or replace fuses or correct wiring or plumbing, or correction of unauthorized repairs/installation.
2. Failure of product to perform during power failures and interruptions or inadequate electrical service.
3. Damage caused by leaky or broken water pipes, frozen water pipes, restricted drain lines, inadequate or interrupted water supply or inadequate supply of air.
4. Damage resulting from operating the product in a corrosive atmosphere or contrary to the instructions outlined in the product owner's manual.
5. Damage to the product caused by accidents, pests and vermin, lightning, wind, fire, floods, or acts of God.
6. Damage resulting from misuse, abuse, improper installation, repair, or maintenance. Improper repair includes use of parts not approved or specified by LG.
7. Damage or failure caused by unauthorized modification or alteration, or if it is used for other than the intended purpose, or any water leakage where the unit was not properly installed.
8. Damage or failure caused by incorrect electrical current, voltage, or plumbing codes, commercial or industrial use, or use of accessories, components, or consumable cleaning products that are not approved by LG.
9. Damage caused by transportation and handling, including scratches, dents, chips, and/or other damage to the finish of your product, unless such damage results from defects in materials or workmanship and is reported within one (1) week of delivery (Call: 1-800-243-0000).
10. Damage or missing items to any display, open box, discounted, or refurbished product.
11. Products with original serial numbers that have been removed, altered, or can not be readily determined. Model and Serial numbers, along with original retail sales receipt, are required for warranty validation.
12. Increases in utility costs and additional utility expenses.
13. Replacement of light bulbs, filters, or any consumable parts.
14. Repairs when your product is used in other than normal and usual household use (e.g. commercial use, offices, and recreational facilities) or contrary to the instructions outlined in the product owner's manual.
15. Costs associated with removal of your product from your home for repairs.
16. The removal and reinstallation of the product if it is installed in an inaccessible location or is not installed in accordance with published installation instructions, including LG's owner's and installation manuals.
17. Shelves, door bins, drawers, handles, accessories, and other parts besides those that were originally included with this particular model.

The cost of repair or replacement under these excluded circumstances shall be borne by the consumer.

For complete warranty details and customer assistance, please call or visit our website:
 Call 1-800-243-0000 (24 hours a day, 365 days a year) and select the appropriate option from the menu, or visit our website at www.lg.com
 Or by mail: LG Customer Information Center:
 P. O. Box 240007, 201 James Record Road Huntsville, Alabama 35813
 ATTN: CIC

Write your warranty information below:

Product Registration Information:

Model:
 Serial Number:
 Date of Purchase:

WARRANTY

LG ELECTRONICS CANADA, INC. LG REFRIGERATOR LIMITED WARRANTY - Canada

WARRANTY: Should your LG Refrigerator ("Product") fail due to a defect in material or workmanship under normal home use during the warranty period set forth below, LG Canada will at its option repair or replace the Product upon receipt of proof of original retail purchase.

This warranty is valid only to the original retail purchaser of the product and applies only to a Product distributed in Canada by LG Canada or an authorized Canadian distributor thereof. The warranty only applies to Products located and used within Canada.

WARRANTY PERIOD: (Note: If the original date of purchase can not be verified, the warranty will begin sixty (60) days from the date of manufacture).		
Refrigerator/Freezer	Sealed System (Compressor, Condenser, and Evaporator only)	
One (1) year from the date of original retail purchase	One (1) year from the date of original retail purchase	Seven (7) years from the date of original retail purchase
Parts and Labor (internal/functional parts only)	Parts and Labor	Parts only (Consumer will be charged for labor).

Noises associated with normal operation and failure to follow instructions found in the use and care and installation guides or operating the unit in an unsuitable environment will not be covered under this warranty.

- ▶ Replacement products and parts are warranted for the remaining portion of the original warranty period or ninety (90) days, whichever is greater.
- ▶ Replacement products and parts may be new or remanufactured.
- ▶ LG Authorized Service Center warranties their repair work for thirty (30) days.

LG CANADA'S SOLE LIABILITY IS LIMITED TO THE WARRANTY SET OUT ABOVE. EXCEPT AS EXPRESSLY PROVIDED ABOVE, LG CANADA MAKES NO AND HEREBY DISCLAIMS ALL OTHER WARRANTIES AND CONDITIONS RESPECTING THE PRODUCT, WHETHER EXPRESS OR IMPLIED, INCLUDING, BUT NOT LIMITED TO, ANY IMPLIED WARRANTY OR CONDITION OF MERCHANTABILITY OR FITNESS FOR A PARTICULAR PURPOSE, AND NO REPRESENTATIONS SHALL BE BINDING ON LG CANADA. LG CANADA DOES NOT AUTHORIZE ANY PERSON TO CREATE OR ASSUME FOR IT ANY OTHER WARRANTY OBLIGATION OR LIABILITY IN CONNECTION WITH THE PRODUCT. TO THE EXTENT THAT ANY WARRANTY OR CONDITION IS IMPLIED BY LAW, IT IS LIMITED TO THE EXPRESS WARRANTY PERIOD ABOVE. LG CANADA, THE MANUFACTURER OR DISTRIBUTOR SHALL NOT BE LIABLE FOR ANY INCIDENTAL, CONSEQUENTIAL, SPECIAL, DIRECT OR INDIRECT DAMAGES, LOSS OF GOODWILL, LOST PROFITS, PUNITIVE OR EXEMPLARY DAMAGES OR ANY OTHER DAMAGE, WHETHER ARISING DIRECTLY OR INDIRECTLY FROM ANY CONTRACTUAL BREACH, FUNDAMENTAL OR OTHERWISE, OR FROM ANY ACTS OR OMISSIONS, TORT, OR OTHERWISE. This warranty gives you specific legal rights. You may have other rights which may vary from province to province depending on applicable provincial laws. Any term of this warranty that negates or varies any implied condition or warranty under provincial law is severable where it conflicts with provincial law without affecting the remainder of this warranty's terms.

THIS LIMITED WARRANTY DOES NOT COVER:

1. Service trips to deliver, pick up, install, or repair the product; instruct the customer on operation of the product; repair or replace fuses or correct wiring or plumbing, or correction of unauthorized repairs/installation.
2. Failure of product to perform during power failures and interruptions or inadequate electrical service.
3. Damage caused by leaky or broken water pipes, frozen water pipes, restricted drain lines, inadequate or interrupted water supply or inadequate supply of air.
4. Damage resulting from operating the product in a corrosive atmosphere or contrary to the instructions outlined in the product owner's manual.
5. Damage to the product caused by accidents, pests and vermin, lightning, wind, fire, floods, or acts of God.
6. Damage resulting from misuse, abuse, improper installation, repair, or maintenance. Improper repair includes use of parts not approved or specified by LG.
7. Damage or failure caused by unauthorized modification or alteration, or if it is used for other than the intended purpose, or any water leakage where the unit was not properly installed.
8. Damage or failure caused by incorrect electrical current, voltage, or plumbing codes, commercial or industrial use, or use of accessories, components, or consumable cleaning products that are not approved by LG.
9. Damage caused by transportation and handling, including scratches, dents, chips, and/or other damage to the finish of your product, unless such damage results from defects in materials or workmanship and is reported within one (1) week of delivery (Call: 1-800-243-0000).
10. Damage or missing items to any display, open box, discounted, or refurbished product.
11. Products with original serial numbers that have been removed, altered, or can not be readily determined. Model and Serial numbers, along with original retail sales receipt, are required for warranty validation.
12. Increases in utility costs and additional utility expenses.
13. Replacement of light bulbs, filters, or any consumable parts.
14. Repairs when your product is used in other than normal and usual household use (e.g. commercial use, offices, and recreational facilities) or contrary to the instructions outlined in the product owner's manual.
15. Costs associated with removal of your product from your home for repairs.
16. The removal and reinstallation of the product if it is installed in an inaccessible location or is not installed in accordance with published installation instructions, including LG's owner's and installation manuals.
17. Shelves, door bins, drawers, handles, accessories, and other parts besides those that were originally included with this particular model.

The cost of repair or replacement under these excluded circumstances shall be borne by the consumer.

For complete warranty details and customer assistance, please call or visit our website: Call 1-888-542-2623 (24 hours a day, 365 days a year) and select the appropriate option from the menu, or visit our website at www.lg.com

Write your warranty information below:

Product Registration Information:

Model: _____
 Serial Number: _____
 Date of Purchase: _____

GARANTÍA

LG ELECTRONICS U.S.A., INC.
FRIGORÍFICO LG GARANTÍA LIMITADA - U.S.A.

En caso de que su Frigorífico LG ("Producto") falle por defectos de material o mano de obra bajo circunstancias de uso doméstico normal durante el período de garantía descrito a continuación, LG, a su criterio, reparará o reemplazará el producto. Esta garantía limitada es sólo válida para el comprador original del producto y se aplicará sólo cuando la compra y el uso se haya realizado dentro de los Estados Unidos, incluyendo los territorios de EE.UU. Para solicitar un servicio cubierto por esta garantía limitada, será necesario presentar el comprobante de compra original.

PERIODO DE GARANTIA		
Frigorífico	(Compresor, Consensador, y Evaporador solamente)	
Un (1) año a partir de la fecha original de compra.	Un (1) año a partir de la fecha original de compra.	Siete (7) años a partir de la fecha original de compra.
Piezas y mano de obra (sólo piezas internas/funcionales)	Piezas y mano de obra	Sólo piezas (Se le cobrará mano de obra al consumidor)

Ruidos asociados con operaciones y fallas normales encontradas en las instrucciones de uso y cuidado y las guías de instalación u operación de la unidad en un ambiente inapropiado no serán cubiertas bajo esta garantía.

- ▶ Los productos y piezas reemplazados están garantizados por la parte que reste del período original de la garantía o por noventa (90) días, el período que sea más largo de los dos.
 - ▶ Los productos y piezas reemplazados pueden ser nuevos o reacondicionados.
- ESTA GARANTÍA SUSTITUYE A CUALQUIER OTRA GARANTÍA, EXPRESA O IMPLÍCITA, INCLUYENDO, SIN LIMITACIONES, CUALQUIER GARANTÍA DE COMERCIABILIDAD O ADECUACIÓN A UN FIN PARTICULAR. HASTA EL EXTREMO PERMITIDO POR LA LEY PARA UNA GARANTÍA IMPLÍCITA, LA DURACIÓN SE LIMITA AL PERIODO DE GARANTÍA EXPRESA INDICADO ANTERIORMENTE. NI EL FABRICANTE NI EL DISTRIBUIDOR DE EE.UU. SERÁN RESPONSABLES DE CUALQUIER DAÑO EXTRAORDINARIO POR MOTIVOS AJENOS, INDIRECTOS, ESPECIALES, O DAÑOS PUNITIVOS DE CUALQUIER NATURALEZA, INCLUYENDO SIN LIMITACIONES, PÉRDIDAS DE BENEFICIOS, O CUALQUIER OTRO DAÑO YA SEA MENCIONADO EN EL CONTRATO, ACUERDO, O CUALQUIER OTRO SUPUESTO. Algunos estados no permiten la exclusión o limitación de daños extraordinarios o ajenos o limitaciones sobre la duración de una garantía implícita, por lo tanto la exclusión o limitación citada arriba puede que no se le aplique a usted. Esta garantía le otorga derechos legales específicos y podría tener otros derechos que variarán dependiendo del estado.**

ESTA GARANTÍA LIMITADA NO CUBRE:

1. Desplazamientos del servicio para entregar, recoger, instalar o reparar el producto, instruir al cliente en el funcionamiento del producto, reparar o reemplazar fusibles o corregir cableados o fontanería o para realizar correcciones de reparaciones o instalaciones no autorizadas.
2. Averías de funcionamiento del producto durante cortes eléctricos e interrupciones del servicio eléctrico.
3. Daños causados por tuberías de agua con fugas o rotas, tuberías de agua congeladas, conductos de drenaje bloqueados, suministros de agua inapropiados o interrumpidos o suministros de aire inadecuados.
4. Daños provocados por un uso del producto en una atmósfera corrosiva o contraria a las instrucciones enmarcadas en el manual del propietario del producto.
5. Daños al producto provocados por accidentes, plagas y parásitos, rayos, viento, fuego, inundaciones o actos de la Naturaleza.
6. Daños provocados por un uso indebido, abuso, instalación, reparación o mantenimiento inadecuados. Una reparación inadecuada que incluya piezas no aprobadas o especificadas por LG.
7. Daños o fallos provocados por una modificación o alteración no autorizada, o por un uso más allá de su propósito o cualquier fuga de agua causada por una incorrecta instalación de la unidad.
8. Daños o fallos provocados por una incorrecta corriente eléctrica, voltaje, normativas de fontanería, uso comercial o industrial, o uso de accesorios, componentes, o productos de limpieza desechables que no estén aprobados por LG.
9. Daños provocados por transporte y manipulación, incluyendo arañazos, limaduras, astillados y/o cualquier otro daño al acabado de su producto, a menos que tales daños sean producto de defectos en los materiales o en la fabricación y sea informado en el plazo de una (1) semana desde su entrega (Llame al: 1-800- 243-0000).
10. Daños u objetos desaparecidos de cualquier producto de presentación, con la caja abierta o productos rebajados o reacondicionados.
11. Productos cuyo número de serie original haya sido retirado, alterado o no sea legible con claridad. Para la validación de la garantía serán necesarios el recibo de compra original, el número de serie y el número del modelo.
12. Incrementos de los costes de utilidad y gastos de utilidad adicionales.
13. Sustitución de bombillas, filtros o cualquier otra pieza desechable.
14. Reparaciones cuando su producto haya sido usado de forma diferente al uso doméstico normal (p.ej. uso comercial, en oficinas y lugares de ocio) o contrario a las instrucciones enmarcadas en el manual del propietario del producto.
15. Costes asociados a la retirada del producto de su hogar para reparaciones.
16. La retirada y reinstalación del producto si se encuentra instalado en un lugar inaccesible o no está instalado de acuerdo con lo publicado en el manual de instalación del producto, incluyendo los manuales LG del propietario y de instalación.
17. Las estanterías, cestas de las puertas, cajones, manillas, y otras piezas a parte de aquellas que venían incluidas con este modelo en particular.

El costo de la reparación o sustitución bajo estas circunstancias excluidas será asumido por el cliente.

Para obtener una información más detallada de la garantía y asistencia al cliente, Por favor llame o visite nuestra página web:
Llame al 1-800-243-0000 (24 horas al día, 365 días al año) y seleccione la opción apropiada del menú o visite nuestra página web en: www.lg.com
O por correo: Centro de información al cliente LG:
P. O. Box 240007, 201 James Record Road Huntsville, Alabama 35813
ATTN: CIC

Escriba la información de su garantía debajo:

Información de registro del producto:

Modelo:
Número de serie:
Fecha de la compra:

TABLE OF CONTENTS

Warranty	1-3	Crisper Humidity Control	18
		Glide 'N' Serve	18
		Door Bins	18
English Version	4	Dairy Bin	18
		DuraBase	19
		Durabase Divider	19
Spanish Version	31	Pull Out Drawer	19
Important Safety Instructions	5-6	Refrigerator Care and Cleaning	20-21
Requirements for Ground Connection	6	Refrigerator Cleaning	20
		Outside	20
		Inside Walls	20
Parts and Features	7	Door Lining & Gaskets	20
		Plastic Parts (Covers and Panel)	20
Refrigerator Installation	8-14	Back Cover	20
Unpacking	8	Replacing Refrigerator Lights	20
Installation	8	Power Interruptions	21
Installation of Base Grille	8	When Going on Vacation	21
How to remove and Install the Refrigerator Doors	9-12	When Moving	21
How to remove and Install Pull-Out Drawer	12-13		
Closing and Aligning the doors	14	About the Automatic Ice Maker	22
Using your Refrigerator	15-19	Connecting the Water Line	23-25
Ensuring Proper Air Circulation	15		
Multi Flow	15		
Door Alarm	15	Troubleshooting Guide	26-28
Adjusting the Controls	15		
Adjusting Control Settings	16		
Food Storage Guide	16		
Storing Frozen Food	16-17		
Refrigerator Section	17-19		
Refrigerator Shelves	17		

IMPORTANT SAFETY INSTRUCTIONS

SAFETY MESSAGES

This manual contains several important safety notices. Always read and obey all of the following safety messages.



This is the safety alert symbol. This symbol is a warning to potential dangers that could cause death, injury or damage to you, others or the product. All safety messages will follow after this warning symbol and the word "DANGER", "CAUTION" or "WARNING". These words mean:

DANGER

You may be killed or suffer fatal damage if you do not follow instructions.

WARNING

You may be killed or seriously injured if you do not follow instructions.

CAUTION

Indicates a potentially hazardous situation which, if not avoided, may result in minor injury or damage to the product.

All safety messages inform you of potential danger, advise you on how to reduce the risk of injury and tell you what can occur if the instructions are not followed.

WARNING

To reduce the risk of fire, electrical shock or personal injury, the following precaution measures should be followed:

- NEVER disconnect the refrigerator by pulling the power cord, always grip the plug firmly and disconnect it directly from the outlet.
- Immediately repair or replace all faulty or damaged service cables. Do not use cords that have cracks or abrasion damage on the length of the cord or on the plug.
- When moving your refrigerator, take care not to roll over the electrical cord.
- **DO NOT** store or use gasoline or other combustible liquids or vapors in proximity with this or any other electrical appliance.
- **DO NOT** permit children to climb, stand or swing from the doors or shelves of the refrigerator. This can cause serious injury to them and damage to the product.
- Keep your fingers away from areas in which they can become caught, such as the doors, hinges and cabinets. Be careful closing the doors when children are near.
- Unplug the refrigerator before cleaning or repairing. **NOTE:** We strongly recommend that any repair services be performed by a qualified professional.
- Before replacing a burned-out light bulb, unplug the refrigerator or shut down the circuit breaker to avoid contact with a live wire (the bulb could break while being replaced). **NOTE:** Setting the control to the OFF position does not disconnect the power from the light bulb circuit.
- Do not keep bottles in the freezer compartment, they could explode after freezing and cause damage.
- For your safety, this product should be properly grounded. Have a qualified professional check the electrical circuit and outlet to ensure a proper ground connection.
- Read all instructions before utilizing the product. Utilize this product only as explicitly expressed in this guide.
- Once the refrigerator is operating, avoid touching cold surfaces of the freezer with damp or wet hands; the skin could become adhered to these surfaces.
- In refrigerators with an automatic ice dispenser, avoid contact with moving parts of the ejector mechanism or with the heating mechanism that discharges the cubes. **DO NOT** place your fingers or hands in the ice dispenser mechanism while the refrigerator is connected.
- **DO NOT** refreeze foods which have already thawed. The Department of Agriculture of the United States, in your Bulletin of Home and Gardens No. 69 establishes that:
"...You can refreeze food that has thawed if they contain ice crystals or are cold and below 40 °F (4 °C)".
"...Ground beef, perishable food or seafood that is discolored or has an unpleasant odor should not be frozen or consumed. Consumption of melted ice cream should also be avoided. If the odor or color of food is questionable, discard it. The food may be dangerous to consume".
"Partial thawing or refreezing reduces the quality of the food, especially fruit, vegetables and prepared meals. The quality of red meat is less affected than other foods. Use refrozen products as soon as possible in order to maintain their quality".

KEEP THESE INSTRUCTIONS

⚠ CAUTION

This appliance is not intended for use by children, persons with physical or mental disabilities, persons with reduced sensory or mental capacity, or persons with lack of experience or know-how, unless they have supervision or instruction in relation to the use of the appliance by the person responsible for their safety. Children should be supervised to assure that they do not play with the appliance.

⚠ DANGER: CHILDREN MAY BECOME TRAPPED

Children becoming trapped or suffocated is not a problem of the past. Discarded and abandoned refrigerators are a hazard, even if they remain there "for just a few days". If you would like to dispose of your old refrigerator, please follow the instructions below to prevent any accidents.

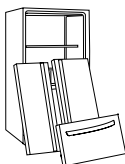

BEFORE DISPOSING YOUR REFRIGERATOR OR FREEZER WHEN NO LONGER IN USE:

- Remove the doors.
- Leave the shelves in place so that children cannot easily become stuck in them.

CFC DISPOSAL

Your old refrigerator may have a cooling system that uses CFC's (chlorofluorocarbons). CFC affects the stratospheric layer of the ozone.

If you decide to throw out your old refrigerator, ensure that CFC contaminants are properly disposed of by a qualified professional. If you intentionally remove the CFC refrigerant, you could be subject to fines or prison in accordance with environmental legislation in effect.

REQUIREMENTS FOR GROUND CONNECTION

IMPORTANT: Attentively read the following.

TO CONNECT ELECTRICITY

⚠ WARNING

ELECTRICAL SHOCK HAZARD

FOR YOUR PERSONAL SAFETY, this appliance must be properly grounded. Have a qualified electrician check your wall outlet to ensure that the plug is grounded properly.

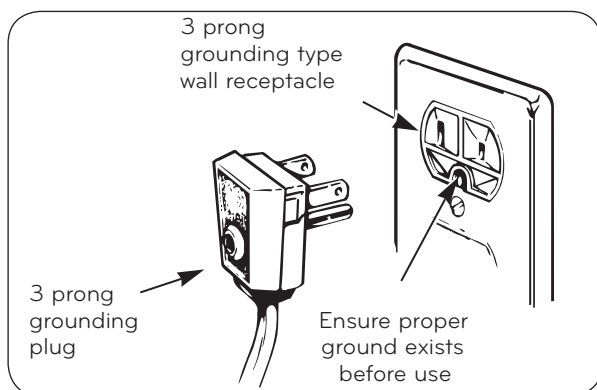

RECOMMENDED GROUNDING METHOD

Your refrigerator must always be plugged to its own outlet which is adequately grounded. The energy current should only be 115 V, 60 Hz, A.C. or 127 V ~ 60 Hz, AC (according to the National rating) and fused at 15 or 20 A. This provides the best performance and prevents an overload which could cause a fire from the overheating of the cables. It is recommended that a separate circuit be used for this appliance, as well as a receptacle that cannot be disconnected with a switch.

Do not use an extension cable. It is your responsibility and obligation to replace two-prong outlets with that of an adequately grounded three-prong outlet.

Do not, under any circumstance, cut or extract the third prong from the plug.

NOTE: Before installation, cleaning or replacing light bulbs, you must disconnect the appliance from the power source. When finished, plug the appliance back in and adjust the thermostat to the desired position.

USE OF EXTENSION CABLES

We do not recommend the use of extension cables.

However, if you still choose to utilize an extension cable, it is absolutely necessary that it is listed in the UL (in the United States) or CSA (in Canada), that it supports three-pronged plugs and that the electrical current support a minimum of 15 A and 120 V.

The use of an extension cable will increase the amount of space needed behind the refrigerator.

⚠ WARNING

REPLACING ELECTRICAL CABLE

If the power cord is damaged, it must be replaced by our service center or qualified LG technician to avoid any risk.

PARTS AND FEATURES

Drawer Model

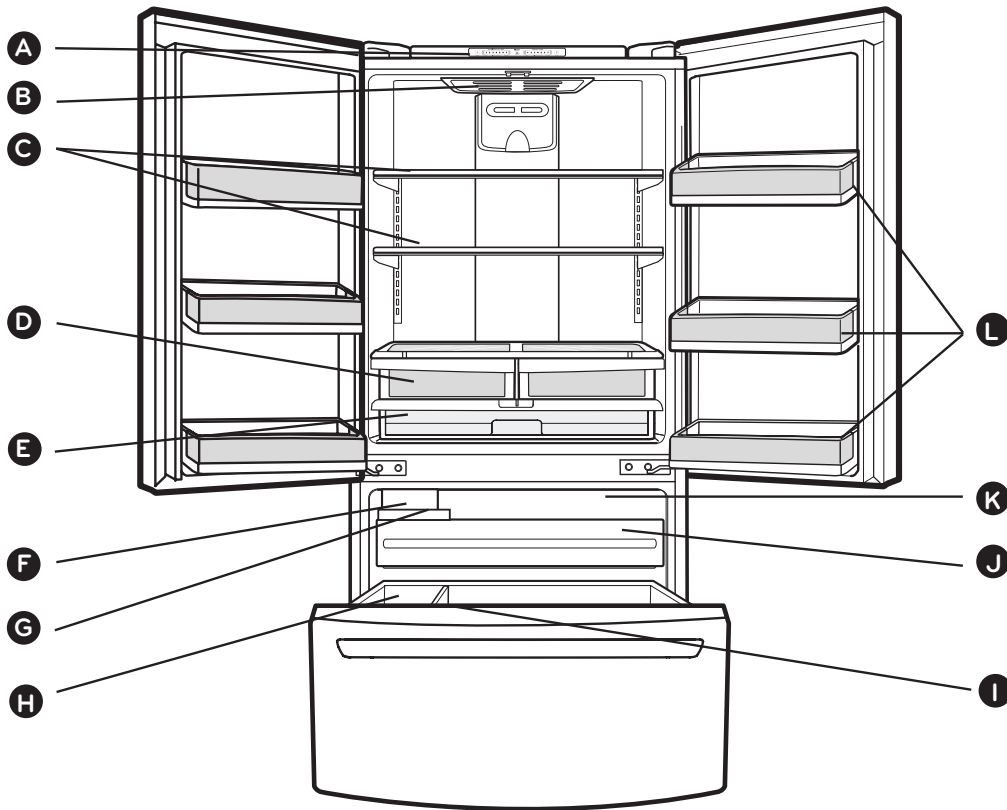

Read this section to familiarize yourself with the parts and features of your new refrigerator.

NOTE: This guide covers different models. Your refrigerator could have some or all of the features and parts listed below. The location of some of the parts may not correspond to that of your model.

- | | |
|--|---------------------------|
| A Refrigerator Temperature Control | I Durabase divider |
| B Refrigerator Light | J Pull Out Drawer |
| C Shelves | K Freezer Light |
| D Optibin Crisper
Keeps fruits and vegetable fresh and crisp | L Door Racks |
| E Pantry * | |
| F Ice Maker * | |
| G Ice Bin* | |
| H Durabase | |

* On some models

REFRIGERATOR INSTALLATION

⚠ WARNING

EXCESSIVE WEIGHT HAZARD

Use the assistance of two or more persons to move or install the refrigerator. Not following these instructions may cause injury to the back and other parts of the body.

UNPACKING

Before installing your refrigerator, remove any tape or temporary stickers. Do not remove any stickers that feature warnings, the model serial number or the technical label of the product located on the back of the refrigerator.

To remove adhesive tape residue, rub it well with your fingers and a little liquid detergent. Clean with warm water and let dry.

Do not use sharp instruments, rubbing alcohol, flammable liquids or abrasive cleaning products to remove the adhesive tape or glue. These products can damage the surface of your refrigerator. For more information, see the section on "Important Safety Instructions".

The shelves come already installed in their factory position. Remove the shelves and replace them according to your spacing needs.

Moving Your Refrigerator:

Your refrigerator is extremely heavy. Make sure you protect the floor when moving your refrigerator for cleaning or servicing. Always pull your refrigerator straight out when moving it. Do not shift from side to side or "walk" the refrigerator when attempting to move it as this can cause damage to the floor.

⚠ WARNING

EXPLOSION HAZARD



Keep all flammable materials and vapors (such as gasoline) away from the refrigerator. Not following these instructions may cause death, explosion or fire

INSTALLATION

1. Avoid placing the unit near heat sources, direct sunlight, or humidity.
2. To avoid vibration, the unit should be leveled. If needed, adjust the leveling screws to compensate for an unlevelled floor. The front should be slightly taller than the rear to ensure that the doors close properly. The leveling screws can easily be turned by slightly tilting the front of the refrigerator, turning the leveling screws clockwise (➡) to raise it and counter-clockwise (⬅) to lower it.

3. Install the refrigerator in an area between 55 °F (13 °C) and 110 °F (43 °C). If the surrounding temperature is lower or higher than previously mentioned, it can adversely affect the unit.

⚠ **CAUTION:** Avoid placing the unit near heat sources, direct sunlight or humidity.

ONCE INSTALLED

1. Carefully clean your refrigerator and remove and dust accumulated during shipping.
2. Install accessories such as the ice bin, door racks, shelves, etc., in their proper places. These are already packed to prevent any possible damage during shipping.
3. Leave your refrigerator on for 2 to 3 hours before storing food inside. Verify that there is a flow of cold air in the freezer compartment to ensure proper cooling. Your refrigerator is now ready for use.

⚠ WARNING:

- Take care when working with the hinges, base cover and stops, etc. You may injure yourself.
- DO not place your hands or any tools in the air vents, the base cover or in the bottom of the refrigerator. This may cause injury or electrical shock.

INSTALLATION OF BASE GRILLE

Uninstalling or Replacing the Base Grille

1. Remove the 2 screws from the bottom front part of your refrigerator (see Figure A).
2. Take off the cover.

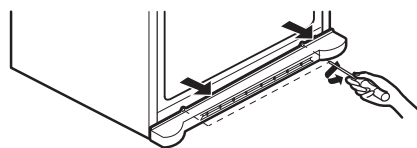

Figure A

Installing the Base Grille

1. Align the bottom cover and place in position. Insert the 2 screws and twist in place (see Figure B).

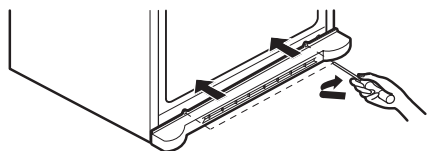
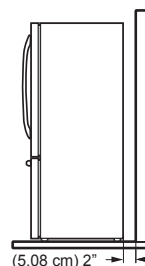

Figure B

Keep a Proper Distance from Adjacent Objects

Please keep the refrigerator at an adequate distance from other objects. Insufficient spacing can reduce the refrigerator's freezing efficiency and increase electricity consumption.



REFRIGERATOR INSTALLATION

HOW TO REMOVE AND INSTALL THE REFRIGERATOR DOORS

For moving the refrigerator through a house door, it might be necessary to remove refrigerator and freezer door handles.

IMPORTANT: Before starting, turn off and unplug the refrigerator. Remove all food and the racks from the doors.

TOOLS YOU MIGHT NEED OR USE



1. Removing Refrigerator Door

NOTE: The appearance of the handle, hinge and cover hinge might be different. Also the screws quantity used in cover hinge might vary according to your model specification. THE APPEARANCE VARIATION DOES NOT AFFECT REMOVING OR INSTALLING DOORS.

Left Door

- With the Phillips screw driver, loose the screw from the upper lid (1) remove it after that.

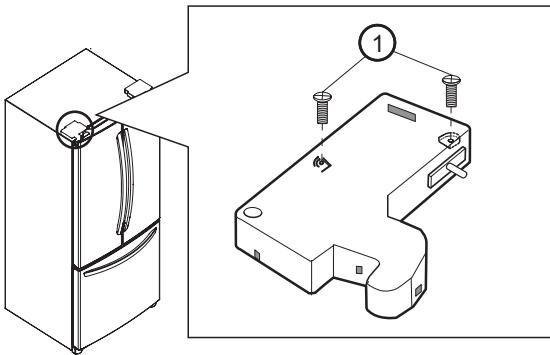

- With the 10 mm socket wrench, loose the two pins from the hinge (2) and remove it (3).

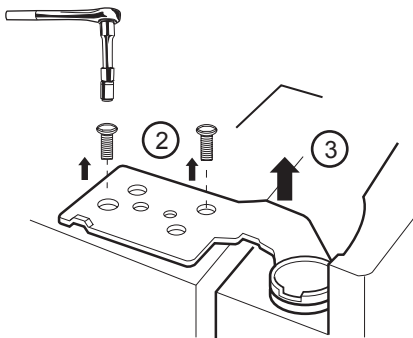

- Place the door with the inner face over the surface so it won't scratch.

Right Door

- Loose both screws from the upper lid (4) and remove it.

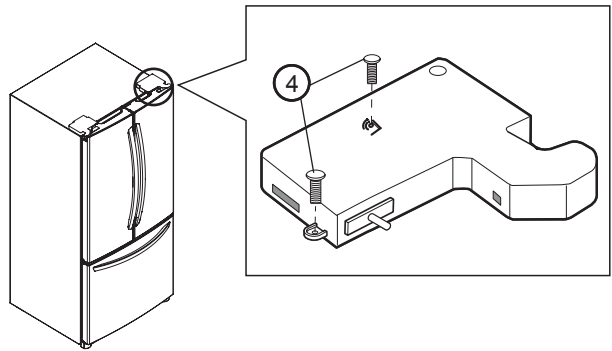

- Unplug the cable harness pulling up the hook located in the upper part of it (5) and separate both parts of the harness (6).

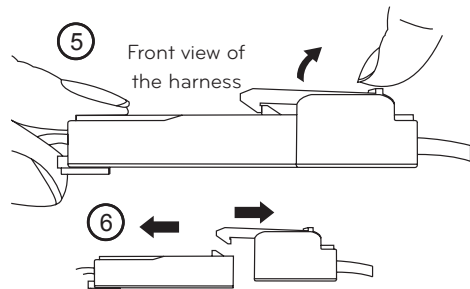
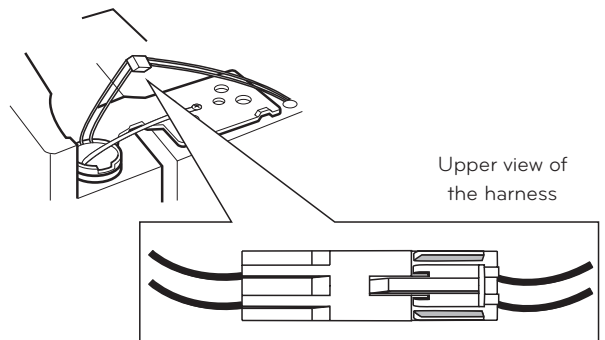

REFRIGERATOR INSTALLATION

- Loose the grounding screw (7) and the pins (8) located over the hinge, after, lift the hinge and remove it (9).

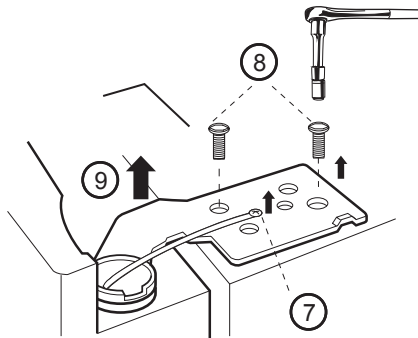

- Plug the cable harness (5).

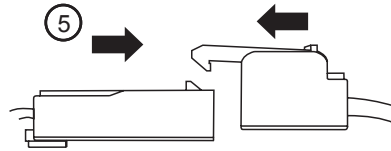

- Remove the door and place it over its inner face to avoid scratching.

2. To install the refrigerator doors

Right Door

- Take the door and place it gently over the pin of the hinge (1).

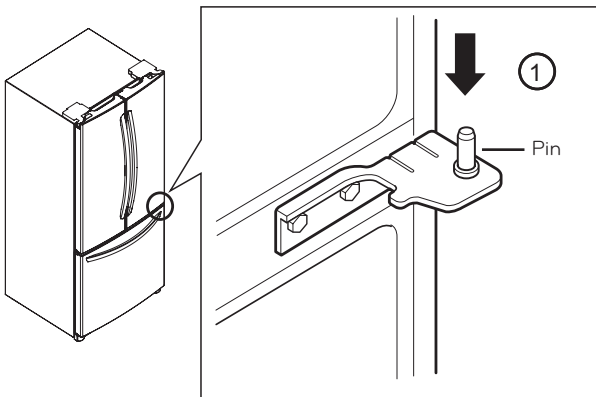

- Place the hinge lid (6) and install both screws (7). Be sure the door is correctly assembled.

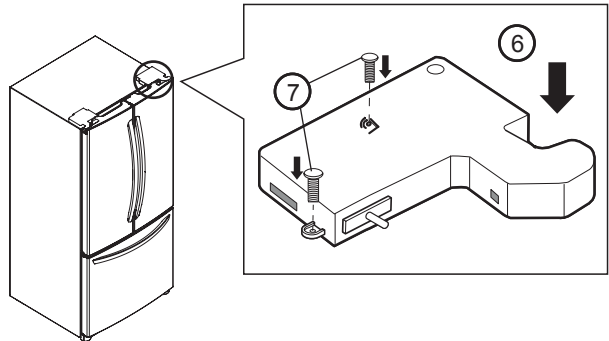

Left Door

- Take the left door and place it over the hinge (8).

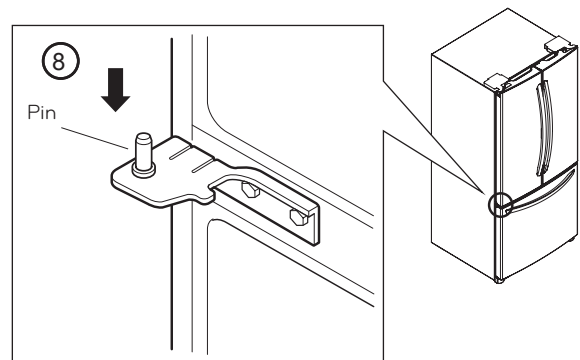

- Place the hinge in its original position (2) assembly the two pins (3) and the ground screw (4).

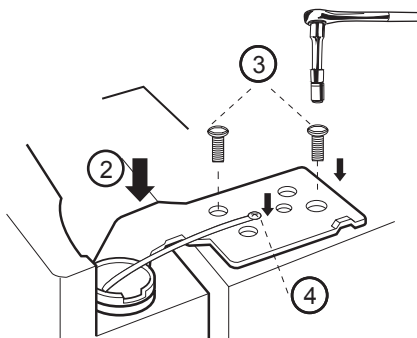

- Place the hinge in its original position (9) and place the two screws (10).

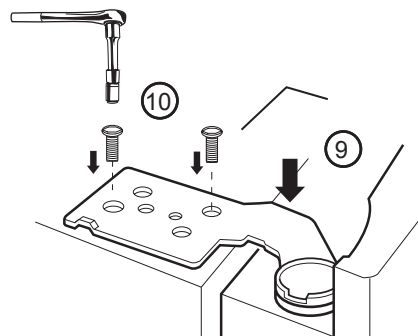

REFRIGERATOR INSTALLATION

- Place the hinge's lid (11) and screw the two screws (12). Check that the door is well installed.

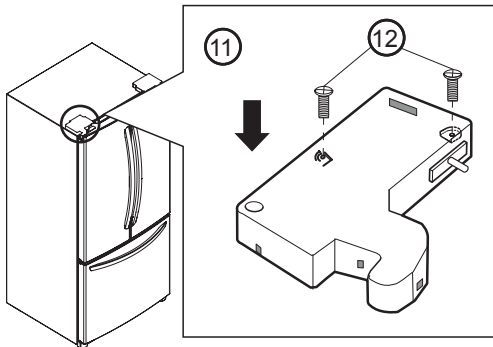

4. To install the handle of the refrigerator

- Install the mounting screws over the door (1) place the handle over them (2) and tight the screws up (3).

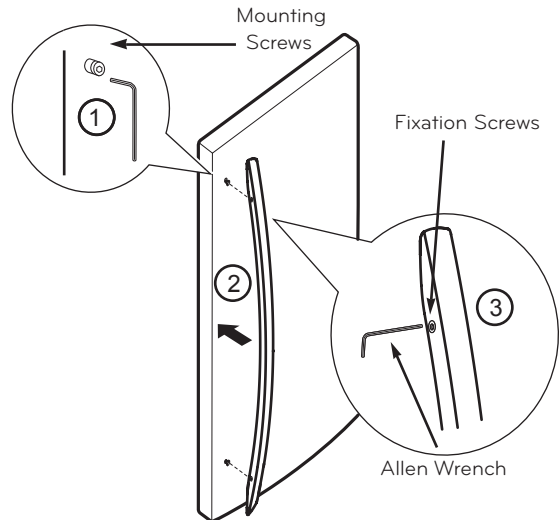

3. To remove the refrigerator handle

- Loose the screws (1) with the Allen tool 3/32" and remove the handle (2).
- Remove the mounting screws with the 1/4" Allen tool (3).

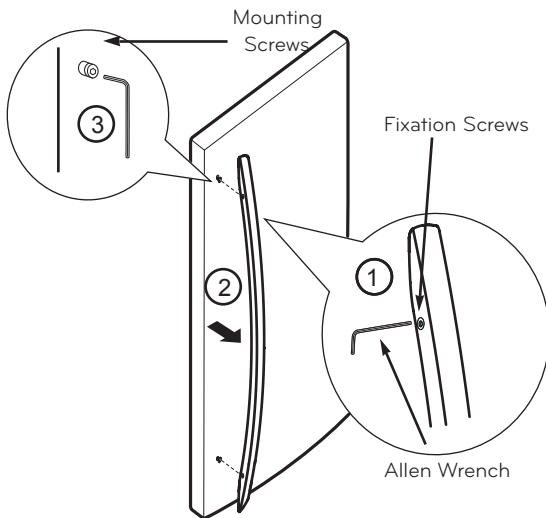

5. To remove the freezer handle

- With an 3/32" Allen tool, loose the screws (1) located the bottom of the handle, remove it (2) remove the screws on from the door (3) with an 1/4" Allen tool.

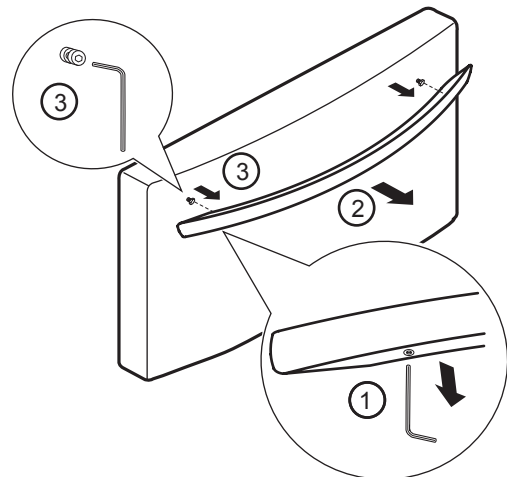

REFRIGERATOR INSTALLATION

6. To install the freezer handle

- Install the mounting screws over the door (1) place the handle over them (2) and tight the screws up (3).

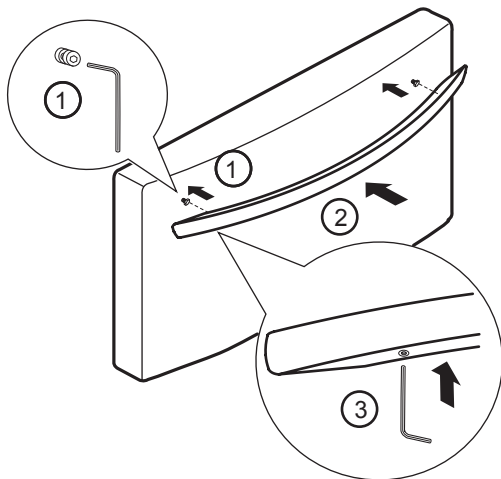

- Remove the screws (2) from both sides of the rail track.

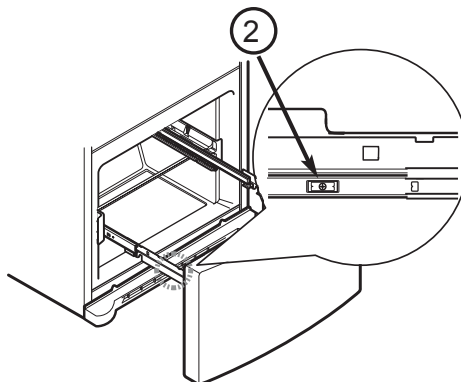

- With both hands, hold both sides of the door and pull up to separate it.

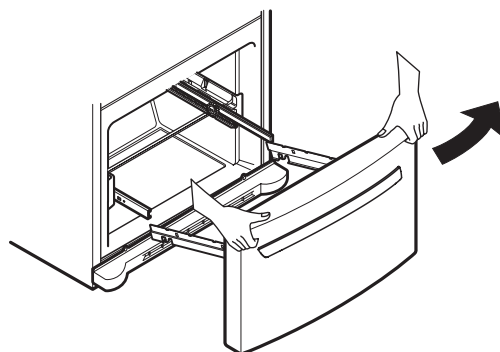

HOW TO REMOVE AND INSTALL THE PULL OUT DRAWER

IMPORTANT: To avoid possible injury or damage to the product or your property, please use two people to perform the following instructions:

1. Removing the Pull Out Drawer

- Pull the drawer out to maximum extension. Remove the bottom rack (1) by tilting it back a little and then lifting it off the railing tracks.

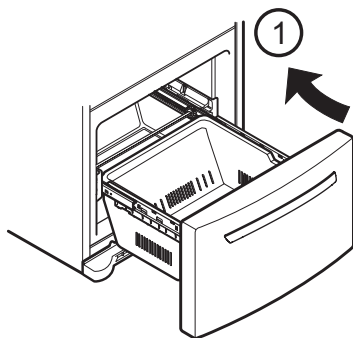

REFRIGERATOR INSTALLATION

- With both hands, hold the center of the bar and push it in so that it is fit to both rails simultaneously.

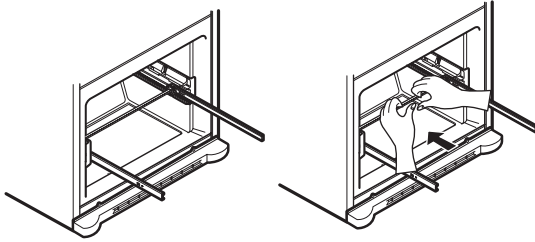

- Push the drawer down into position and tighten the screws (3).

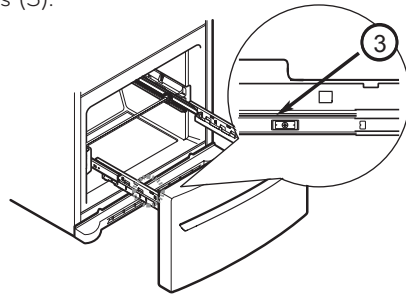

- ⚠ CAUTION:** When removing the drawer, do not hold the handle. If it comes off, it could cause personal injury.

- ⚠ CAUTION:** To place the drawer on the floor, take care not to damage the floor or hurt your feet with the sharp edges on the side with the hinges.

2. Installing the Pull Out Drawer

- With both hands, hold the center of the bar and pull it outward so that the two rails extend out at the same time.

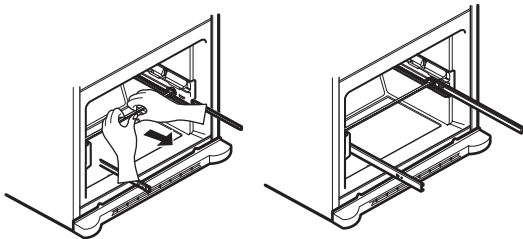

- With the drawer fully extended, insert the lower basket over the front part of the rail assembly and then the back part (4).

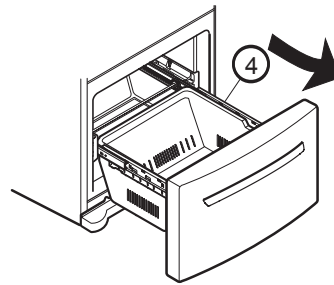

- Mount door supports (1) into the tabs on the railing track (2), starting in the back first and then connecting the part in the front last, as shown in the figure.

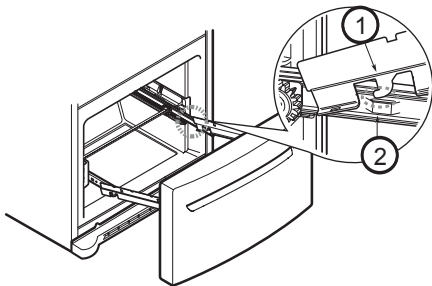

- ⚠ WARNING:** To prevent entrapment risk and accidental child or animal suffocation, DO NOT permit them to play inside of the drawer.

- ⚠ WARNING:** DO NOT step or sit on the Freezer Door.

REFRIGERATOR INSTALLATION

CLOSING AND ALIGNING THE DOORS

Closing the Doors

Your refrigerator has two front leveling screws, one on the right and one on the left. If your refrigerator seems unstable or if you would like the doors to close more easily, simply adjust the inclination of the refrigerator by following the instructions below:

1. Plug the refrigerator into a 3 prong grounded outlet. Move the refrigerator into its final position.
2. Remove the base grille (Refer to the section on "Installation of Base Grille").
3. Use a flat head screwdriver to adjust the leveling screws, turning clockwise to raise the side of the refrigerator and counter-clockwise to lower it. It may take several turns to adjust it to the inclination you would like.

NOTE: Having someone push against the top of the refrigerator takes some weight off the leveling screws. This will make it easier to adjust the screws.

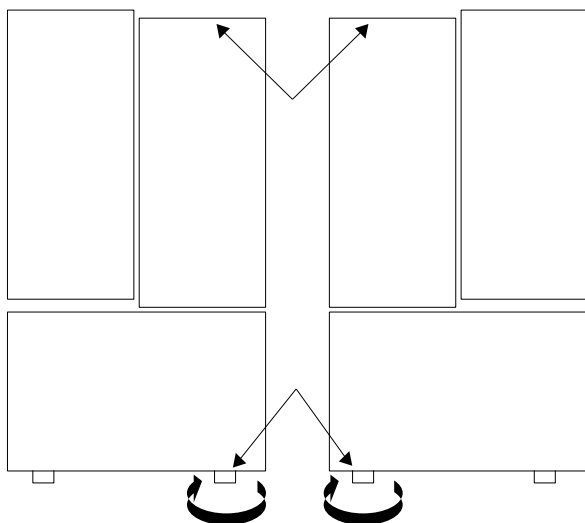

4. Open both doors again and check to make sure that they close easily. If not, slightly tilt the refrigerator further back by turning both leveling screws clockwise. It may take several more turns. Make sure that you turn both leveling screws the same amount.
5. Ensure that the refrigerator is even by using a level.
6. Replace the base grille.

NOTE: Your new refrigerator is uniquely designed with two fresh food doors. Either door can be opened or closed independently of one another. You may have to exert slight pressure on doors to get them to close completely.

Aligning the Doors

If the spacing between the doors is uneven, follow the instructions below to align them:

1. With one hand, lift up the door you want to raise at middle hinge.
2. With other hand, use pliers to insert snap ring as shown.
3. Insert additional snap rings until the doors are aligned (Three snap rings are provided per unit).

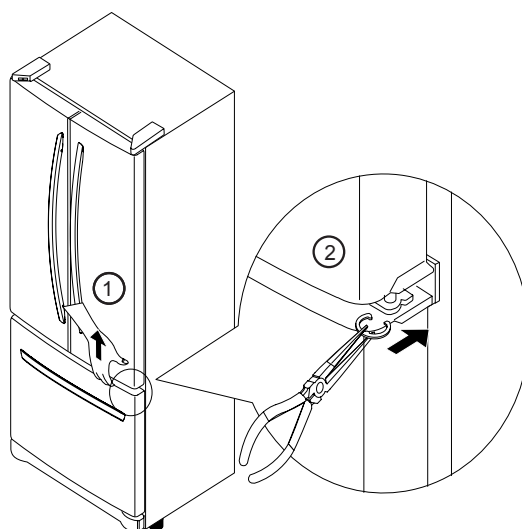

When moving your refrigerator

Note: Your refrigerator is extremely heavy. When moving the refrigerator for installing, cleaning or service be sure to follow the next instructions.

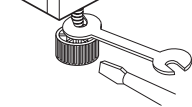
1. Adjust leveling legs up. 
2. Cover the floor with cardboard or hardboard to avoid floor damage.
3. Always pull or push the refrigerator straight out when moving it. Do not wiggle or "walk" the refrigerator when trying to move it, as floor damage could occur.

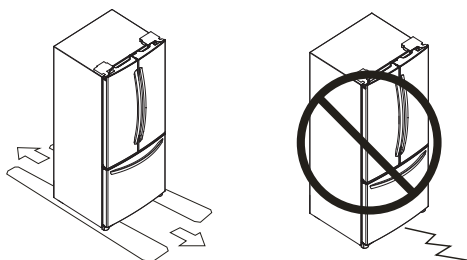

USING YOUR REFRIGERATOR

ENSURING PROPER AIR CIRCULATION

In order to obtain stable temperature, the air must flow between the freezer and refrigerator sections. As shown in the illustration below, the cold air enters through the bottom part and circulates upward. This air returns below the freezer floor and the rest of the air enters the refrigerator section through the top vent.

MULTI FLOW

- The cooling fan operates more powerful and effective than when in normal operation. This is especially noticeable when new food is placed in the refrigerator compartment.
- If the lining is damaged, water or other substances could enter through the cool air vent causing decreased efficiency.

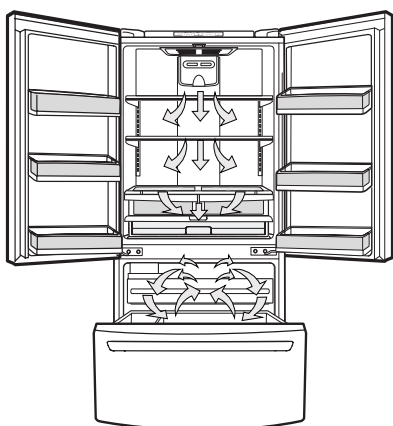

Do not block any of these vents with packages of food. This can interrupt the flow of air and cause temperature and moisture problems.

IMPORTANT: Because air circulates between both sections, any odors formed in one section will transfer to the other. You must thoroughly clean both sections to eliminate odors. To prevent odor transfer and drying out of food, make sure you wrap or cover foods tightly (See the **"Food Storage Guide"** section for details).

DOOR ALARM

With this feature you will hear an alarm when the freezer or refrigerator door is ajar for more than 1 minute. These tones will repeat every 30 seconds. The alarm is cancelled when the door is properly shut.

CAUTION WHEN CLOSING THE DOOR

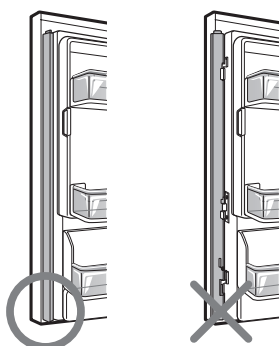

⚠ CAUTION

To reduce the risk of door scratches, please make sure that the refrigerator door mullion is always folded in.

ADJUSTING THE CONTROLS

- Your refrigerator has two controls that allow you to regulate the temperature the freezer and refrigerator compartments.
- Initially set the REFRIGERATOR CONTROL and the FREEZER CONTROL at position number "4". Leave it on these settings for 24 hours (one day) in order to stabilize the refrigerator. After this you may adjust the compartments to your desired temperature.

- **Refrigerator Control: Position 1 to 7 or select from 32 °F to 47 °F (0 °C to 8 °C), according with your refrigerator display type.**

The lower the degree, the colder the refrigerator compartment will become.

TYPE 1



TYPE 2



- **Freezer Control: Position 1 to 7 or select from -6 °F to 9 °F (- 21 °C to -13 °C), according with your refrigerator display type.**

The lower the degree, the colder the freezer compartment will become.

TYPE 1



TYPE 2

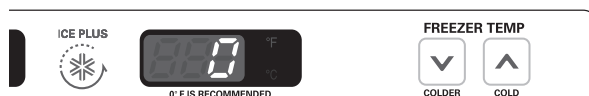

• Ice Plus

Press the button Ice Plus. The LED light will turn on. This function will remain activated for 24 hours and intensify the cooling speed of the freezer and increase ice production.

USING YOUR REFRIGERATOR

ADJUSTING CONTROL SETTINGS

Give the refrigerator time to cool down completely before adding food. It is best to wait 24 hours before adding food to the refrigerator. The mid-settings indicated in the previous section should be correct for normal household refrigerator usage. The controls are set correctly when milk or juice is cold to your liking and ice cream is firm.

The refrigerator control functions as the thermostat for the entire appliance. The higher the number setting, the longer the compressor will run to keep the temperature colder. The freezer control adjusts the cold air flow from the freezer to the refrigerator. Setting the freezer control to a lower temperature keeps more cold air in the freezer compartment to make it colder.

If you need to adjust the temperature in the refrigerator or freezer, begin by adjusting the refrigerator first. Wait 24 hours after the refrigerator adjustment to check the freezer temperature. If it is too warm or too cold, then adjust the freezer control as well.

Use the settings listed in the table below as a guide.

CONDITION/REASON:	RECOMMENDED ADJUSTMENT:
REFRIGERATOR section is too warm <ul style="list-style-type: none"> • Opening the door often • Adding a large amount of food • Room temperature is very warm 	Adjust the REFRIGERATOR setting to the next highest number and wait 24 hours, then check.
FREEZER section is too warm/ ice is made too slowly <ul style="list-style-type: none"> • Opening the door often • Adding a large amount of food • Room temperature is very low (not cycling often enough) • Using ice frequently • Air vents blocked by objects 	Adjust the FREEZER setting to the next highest number and wait 24 hours, then check. Remove any objects blocking air flow.
REFRIGERATOR section is too cold <ul style="list-style-type: none"> • Controls not set correctly for your conditions 	Adjust the REFRIGERATOR setting to the next lowest number and wait 24 hours, then check.
FREEZER section is too cold <ul style="list-style-type: none"> • Controls not set correctly for your conditions 	Adjust the FREEZER setting to the next lowest number and wait 24 hours, then check.

FOOD STORAGE GUIDE

ITEMS	HOW TO STORE
Storing Fresh Food	Wrap or store food in the refrigerator in airtight and moisture-proof material unless otherwise noted. This prevents food odor and taste transfer throughout the refrigerator. For dated products, check date code to ensure freshness.
Butter or margarine	Store opened butter in a covered dish or in a closed compartment. When storing a larger quantity, wrap in freezer packing and freeze.
Cheese	Store in original packaging until you are ready to use it. Once opened, tightly rewrap with plastic wrap or aluminum foil.
Vegetables with skins (carrots, peppers)	Place in bags or plastic containers inside the crisper.
Fruit	Wash and let dry; store in plastic bags in the refrigerator. Do not wash or pit berries until you are ready to eat them. Berries should be selected and kept in their original packaging (if there is any) or in a paper bag closed halfway and set on a shelf.
Leafy Vegetables	Remove original packaging and trim any dirty or discolored parts. Wash in cold water and drain. Place in a plastic bag or plastic container and store in the crisper.
Fish	Consume fish or seafood the same day purchased.
Chef Fresh	Store any meat in original airtight, moisture-proof packaging. Rewrap if necessary.
Leftovers	Cover leftovers with plastic wrap or aluminum foil. Plastic containers with airtight lids can also be used.

STORING FROZEN FOOD

NOTE: For more information on how to prepare food to be frozen such in a way to see the period they can be stored consult a frozen food guide or cook book.

Packaging

A great freezing depends on how great you package the food. When you seal the package make sure you remove all excess air and do not allow humidity. A package that is incorrectly sealed will result in the transmission of bad odors, contaminants inside your refrigerator and will cause your foods to dry.

USING YOUR REFRIGERATOR

Packaging Recommendations:

- Use sealed plastic containers.
- Use plastic containers with a smooth surface.
- Package with aluminum foil of high resistance.
- Wrap with paper layered with plastic.
- Use water proof plastic.
- Use recommended plastic bags to store frozen foods.

Follow these packaging or container instructions in order to reach the best freezing

Do not use:

- Bread Wrapping.
- Plastic container not safe for storing.
- Containers without lids or seals.
- Waxed paper or waxed plastic.
- Thin wrapping paper or not water proof.

Freezing

IMPORTANT: Do not keep bottles in the freezer compartment, they may explode after freezing and cause damage.

For the maximum use of your freezer do not store excess food. Do not introduce a large amount of unfrozen foods that cannot be frozen within 24 hours (no more than 2 – 3 pounds or ,91 kg - 1,36 kg of food per square inch of space in the freezer). Sufficient space must be left in order for the air to circulate properly around the packages. Leave enough space in order to close your refrigerator with out difficulty.

Storage times can vary depending on the type and quality of the food, the way its package, or packaging container used, (in comparison to air and humidity), and the temperature it being stored in. Ice crystals formed inside your package are normal it indicates the air and humidity inside your package have condensed.

NOTE: Let warm foods cool off at room temperature for approximately 30 min, then wrap accordingly with the methods mention above and freeze. By letting your warm foods cool off before you introduce them to your freezer it will save you energy.

⚠ WARNING

SUFFOCATING DANGER

Adequate ventilation is required when using dry ice. Dry ice is Carbon Dioxide (CO₂). When it evaporates it produces oxygen, causing dizziness, slight headaches, unconsciousness or death. Do not inhale these vapors and properly ventilate the room while you use dry ice.

REFRIGERATOR SECTION

REFRIGERATOR SHELVES

The shelving of your refrigerator can be adjusted to comply with your storage necessities; Depending on the model you have in can include glass shelving or wired shelving. The storing of your foods together and adjusting the shelving to different heights will ease to help you locate what you need. This also helps your refrigerator to stay shut longer which will save you energy.

IMPORTANT: While your refrigerator glass shelving are cold do not clean with hot or warm water. The glass shelving may break if exposed to rapid temperature changes or hard impacts. For your safety the glass shelving are made out of tempered glass so when at breaking they will fracture into tiny fragments.

NOTE: Be careful while moving or relocating the shelves they are heavy. If moving the shelves is required keep in mind to locate them in a safe environment to prevent them from breaking.

Adjusting Shelves

Remove the shelves and adjust them to your convenience.

• Removing Shelves

Incline the front of the shelf in the direction indicated by figure 1 and lift in the direction indicated by figure 2. Pull the shelf towards you.

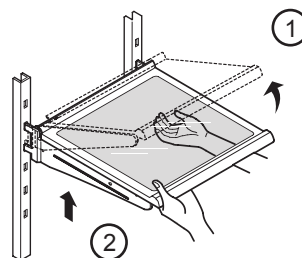

• Replacing Shelves

Incline the frontal part of the shelf (1) and guide the shelf hooks towards the openings at the height desired. Then lower the front of the shelf (2) so the hooks can be inserted (3) in the shelf supports.

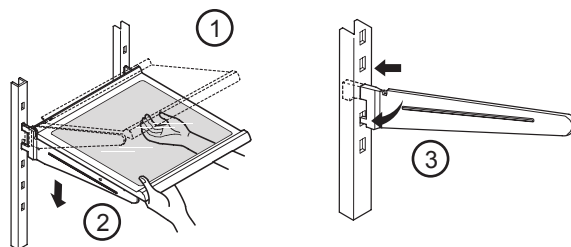

NOTE: Make sure that the shelf is installed in the horizontal manner. If not secured it can cause the shelves to fall, which will cause your stored food to spill.

USING YOUR REFRIGERATOR

HUMIDITY CONTROLLED CRISPER

The crispers provide fresher tasting fruit and vegetables by letting you easily control humidity inside the drawer.

You can control the amount of humidity in the moisture-sealed crispers by adjusting the control to any setting between **HIGH** and **LOW**.

•**HIGH** keeps moist air in the crisper for best storage of fresh, leafy vegetables.

•**LOW** lets moist air out of the crisper for best storage of fruit.

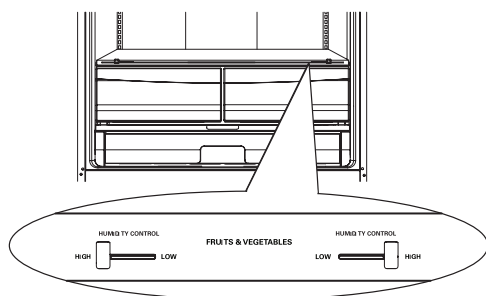

Removing and installing the humidity controlled crisper

1. To remove, pull the drawer out to full extension.
2. Lift the front of the crisper up, then pull it straight out.
3. To install, slightly tilt up the front, insert the drawer into the frame and push it back into place.

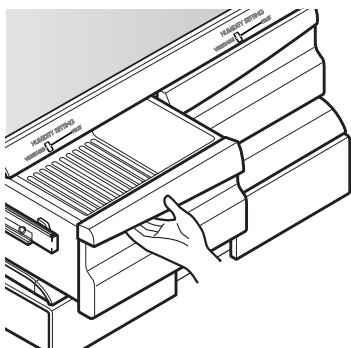

Removing the glass

1. Lift up the glass under the crisper cover.
2. Pull the glass up and out.

NOTE: Pantry drawer not shown for clarity.

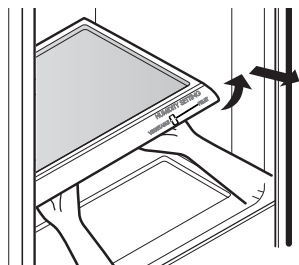

GLIDE 'N' SERVE

The Glide 'N' Serve provides storage space with a variable temperature control that keeps the compartment colder than the refrigerator temperature. This drawer can be used for large party trays, deli items, or beverages.

NOTE: It is not recommended that this drawer be used for fruits and vegetables.

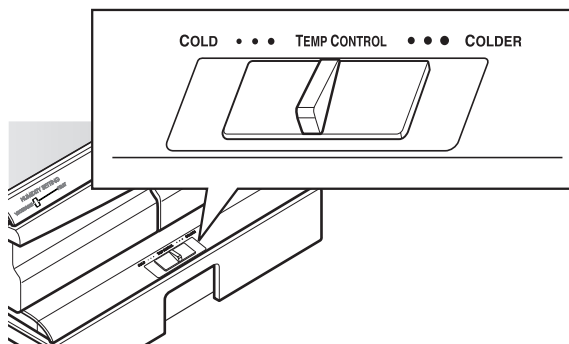

Glide 'N' Serve Control

The control regulates the air temperature in the drawer. Set the control level to **COLD** to provide normal refrigerator temperature. Use the **COLDER** setting for meats or other deli items.

NOTE: Cold air directed to the Glide 'N' Serve can decrease the refrigerator temperature. It may be necessary to adjust the refrigerator temperature.

To remove and replace Glide 'N' Serve

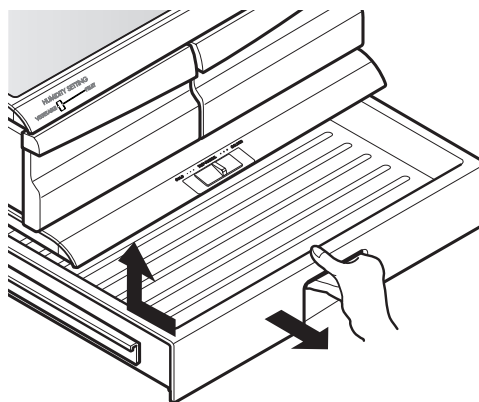

1. To remove, pull the drawer out to full extension.
2. Lift the front of the crisper up, then pull it straight out.
3. To install, slightly tilt up the front, insert the drawer into the frame and push it back into place.

USING YOUR REFRIGERATOR

DOOR BIN

The door bins are removable for easy cleaning and adjustment.

1. To remove the bin, simply lift the bin up and pull straight out.
2. To replace the bin, slide it in above the desired support and push down until it snaps into place.

NOTE: Some bins may vary in appearance and will only fit in one location.

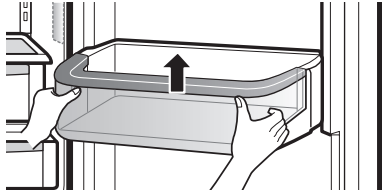

DAIRY BIN (IN SOME MODELS).

1. To remove the dairy bin, simply lift it and pull straight out.
2. To replace the dairy bin, slide it into place and push down until it stops.

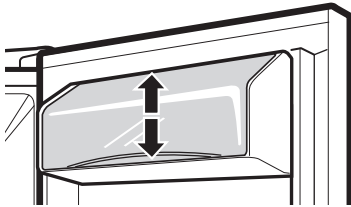

NOTE: The dairy bin will only fit in the top space on the right-hand door.

DURABASE

1. To remove the Durabase, push it to the back as much as possible. Tilt up the front of the Durabase and pull straight out.
2. To replace, insert the Durabase in the rail assembly.

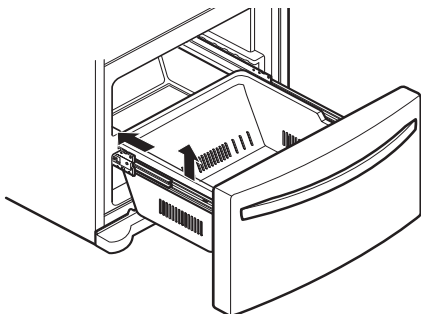

DURABASE DIVIDER

The Durabase divider allows you to organize the Durabase area into sections. It can be adjusted from side to side to accommodate items of different sizes.

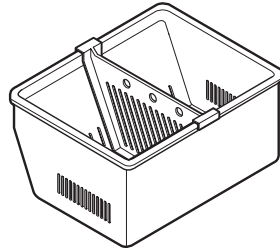

WARNING: If the Durabase divider is removed, there is enough open space for children or pets to crawl inside. To prevent accidental child and pet entrapment or suffocation risk, DO NOT allow children or pets to touch or go near the drawer

PULLOUT DRAWER

1. To remove, pull the drawer out to full extension. Lift the front of the drawer up and then pull it straight out.

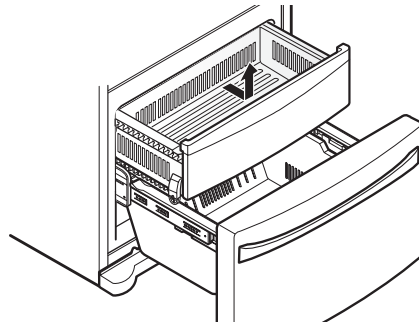

2. To replace, slightly tilt up the front of the drawer, insert the drawer into the frame, and push the drawer back into place.

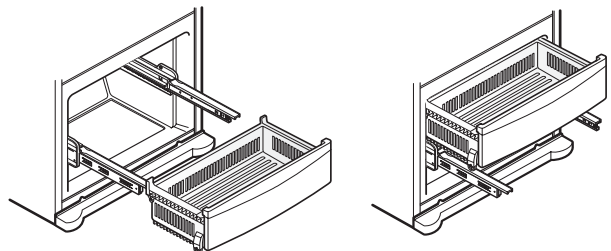

REFRIGERATOR CARE AND CLEANING

⚠ WARNING

EXPLOSION HAZARD



Do not use flammable cleaners. Not following these instructions can cause death, explosion or fire.

The refrigerator, as well as the freezer, do their own de-freezing. This process does not prevent the build up of contaminants, therefore it is suggested that you clean both parts once a month; clean spilled liquids immediately.

REFRIGERATOR CLEANING

- Unplug your refrigerator.
- Pull out all of the removable parts (such as the vegetable and dairy doors).
- Use a clean sponge (or a soft rag) and use it with lukewarm water mixed with detergent. Do not use abrasive or concentrated cleaners.
- Hand wash it, and dry it thoroughly.
- Plug the refrigerator back in.

OUTSIDE

Wax the outside in order to create better protection. Make sure you use a product specifically design to be used for electro-domestic products (car wax is acceptable). Use a clean, soft rag, and perform this task twice a year. For metal-made refrigerators, do not wax, simply clean it with water and detergent. Do not use concentrated or abrasive products.

NOTE: Avoid the usage of chemical products that contain phosphates or bleach.

INSIDE (Allow freezer to slightly warm up a small degree to prevent cloth from sticking)

In order to eliminate bad odors, clean the inside of the refrigerator with a mixture of baking powder and lukewarm water (one teaspoon of baking powder per cup of water). Ensure that the powder dissolves thoroughly, in order to prevent any sort of damage.

DOOR LINING AND GASKETS

Use only a mild detergent (such as dish soap).

PLASTIC PARTS (Covers and Panels)

Do not use abrasive, paper or rough products. These could damage the product.

BACK COVER

⚠ WARNING

ELECTRICAL SHOCK HAZARD

Before you begin, either unplug the refrigerator or turn off power at the circuit breaker or fuse box.

NOTE: Back Cover should only be removed by a qualified technician.

In order to get an efficient performance of your refrigerator, clean the back cover of it at least twice a year.

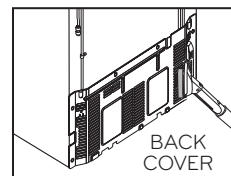

REPLACING REFRIGERATOR LIGHTS

NOTE: The interior lighting for this model uses LED lighting.

DO NOT try to change an LED module. LED lighting should only be replaced by a qualified service technician.

REFRIGERATOR CARE AND CLEANING

POWER INTERRUPTIONS

1. In case of a black out, call your electric company and ask how long it will last.
2. In case of a 24 hour or less black out, do not open the refrigerator; this will keep the food fresh.
3. In case of a longer black out, do one of the following options:
 - Pull out all of the frozen food and keep them in an ice chest.
 - Put 2 lbs (907 g) of frozen ice (make sure you use gloves) for each square foot (28 L) inside the freezer. This task will preserve the food for 2 to 4 days.
 - In case you do not possess neither ice chest or dry ice, consume your food as soon as possible.

REMEMBER: In a power failure, a full freezer stays cold longer than a partially filled one. A freezer full of meat stays cold longer than a freezer full of baked goods. If you see that food contains ice crystals, it may be safely refrozen, although the quality and flavor may be affected.

If the condition of the food is poor or if you feel it unsafe, dispose of it.

WHEN GOING ON VACATION

If you decide to leave your refrigerator on when going away, consider these steps:

1. Consume all of the perishable items and freeze the rest.
2. Empty the ice bin.

If you decide to leave your refrigerator off:

1. Remove all of the food.
2. Unplug your refrigerator.
3. Clean and dry it well.
4. Make sure the doors stay open (use blocks or tape) in order to prevent bad odors and fungi from happening.

WHEN MOVING

If you decide to take your refrigerator with you when moving, consider the following:

1. Remove all of the food from it, and place the frozen food in an ice chest with dry ice.
2. Unplug your refrigerator.
3. Empty the water from its tray.
4. Clean and dry it with a rag.
5. Pull out all of the removable parts, and wrap them with adhesive tape.
6. Depending on the model of the refrigerator, lift the top part of the refrigerator so it can roll with ease, or screw the levelers so it won't scratch the floor. Consult to the section **"Closing and Aligning Doors"**.
7. Keep the doors closed with the cable glued to the refrigerator cabinet with an adhesive tape.

When your refrigerator arrives to your home, put everything back into place and read the section **"Refrigerator Installation"** in order to obtain installation preparation. In case your refrigerator has a factory ice maker, remember you have to reconnect the water supply.

ABOUT THE AUTOMATIC ICE MAKER

NOTE: The automatic ice maker is only included in some models. Check your specifications of your refrigerator.

⚠ WARNING

PERSONAL INJURY HAZARD

Avoid contact with any moving parts of the ejector mechanism or with the heater that releases the ice cubes. **DO NOT** place your fingers in the automatic ice maker when the refrigerator is plugged in.

OPERATING INSTRUCTIONS

After turning on your refrigerator, the ice will start to be made between 12 and 24 hours.

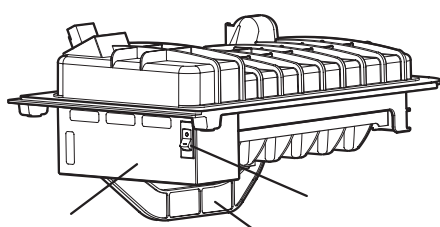

Ice maker

Switch
Sensor

The ice maker produces 12 cubes per cycle (in between 80 and 100 cubes in a 24 hour period), depending on the temperature of the freezer, the times in which the door opens, and other using conditions (amount of food in the freezer, etc).

If the refrigerator is used before the connection of water to the ice maker was performed, you must turn its dial to **O** (off).

When the water connections are performed, turn its dial to **I** (on).

The ice maker will fill up (and start making ice) between 12 and 24 hours after the refrigerator is turned on.

Throw away the first batch of ice. Make sure that nothing interferes with the sensor.

When the ice reaches the sensor, the ice maker will stop to make ice immediately.

It's normal that some ice gets stuck. If the ice is not used frequently, the older cubes of ice will be opaque in color, smaller, and with a strange flavor.

YOU MUST TURN THE SWITCH TO O (OFF)

- When the water supply is interrupted for many hours.
- When the ice container is left out of its place for more than one or two minutes.
- When the refrigerator will not be in use for various days.

NORMAL SOUNDS

- The valve will emit a buzzing sound when the ice maker is full of water. If the switch is placed in the off position the buzz will still be heard even when the water pipe has not been connected. To avoid this sound, move switch to **O** (off) position.

NOTE: The ice maker can get damaged if the switch is kept in the ON position before the water pipe has been connected.

- While the ice maker is filling up with water and producing ice, you will hear the sound of the ice falling and water flowing through the pipes.

PREPARING FOR VACATIONS

Move the ice maker switch to the **O** (off) position and cut the flow of water going into the refrigerator.

If room temperature is at freezing point, have a specialized technician drain the flow of water from the inner pipes (certain models) to avoid broken pipe related damage.

NOTE: It is necessary to have a water source when both water and/or Ice dispensers are available in your product.

CONNECTING THE WATER LINE

BEFORE START

The water source is not guaranteed by the refrigerator manufacturer. Follow instructions carefully in order to reduce damage.

Air located inside the water pipes can cause hammering or tapping causing damage to the inner pipes or water spillage in the inside of the refrigerator. Call a qualified plumber to fix such hammering on the connections before installing the water pipe.

To avoid burn damage or such, never connect refrigerator to hot water pipes.

If you are to use the refrigerator before connecting it to the water source, make sure the ice maker is the off position.

Never attempt to install the ice maker pipes in areas where room temperature is below freezing point.

When using any electrical device (like a drill) during the installation, make sure device is doubly isolated or making ground to prevent risk of electrical surge or discharge.

All installations should be done considering local water and drainage requirements.

- If an inverted osmosis water filtration system is connected to the cold water source, the water hose installation is not assured or guaranteed by the refrigerator or automated ice maker manufacturer. Follow the next instructions carefully to minimize costly water related damages.
- When having an inverted osmosis water filtration system connected to the cold-water flow, the water pressure for such system must be at least between 40-60 PSI or 0,27 MPa ($2,8 \text{ kg} \cdot \text{f} / \text{cm}^2 \sim 4,2 \text{ kg} \cdot \text{f} / \text{cm}^2$, ($2,8 \text{ kg} \cdot \text{f} / \text{cm}^2 \sim 4,2 \text{ kg} \cdot \text{f} / \text{cm}^2$, less than 2 ~ 3 seconds to fill a 7 oz of capacity cup [0,2 liters])).
- If the inverted osmosis water filtration system pressure is less than 21 PSI or 0,14 MPa ($1,5 \text{ kg} \cdot \text{f} / \text{cm}^2$, more than four (4) seconds to fill a 7 oz of capacity cup [0,2 liters]):
 - a) Identify if the sediments filter in the inverted osmosis system is being blocked. Replace filter if necessary.
 - b) Allow inverted osmosis system storage tank to refill after extensive usage.
 - c) Call a qualified plumber if the inverted osmosis water pressure problem continues.

REQUIREMENTS

- **1/4" (6,35 mm) in diameter copper pipe** to connect refrigerator to the water pipe. Make sure both terminals are cut in squared manner.

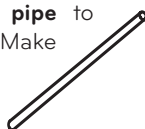

To determine how much pipe material is needed, measures the distances between the valves located behind the refrigerator and the source of water and add to that 8 feet (2,4 m). Make sure there is sufficient pipe material to allow the free movement of the refrigerator from the wall

- **A cold water source.** Water pressure should be between 0,138 and 0,82 MPa or 20 and 120 PSI for models not containing water filter and between 0,276 and 0,82 MPa or 40 and 120 PSI for models containing water filter.

- **A drill.**

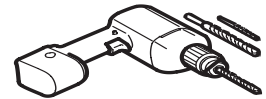

- **Adjustable 1/2" (12,7 mm) key.**

- **Flat and Phillips style (star) screwdriver.**

- **Two 1/4" (6,35 mm) diameter compression nuts** with two sides to connect the copper pipe to the refrigerator valve.

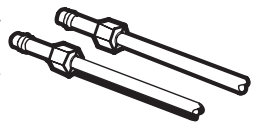

If your current copper pipe has some reduction on the ends, it will be necessary to get and adaptor (found in hardware stores) to connect the water line to the refrigerator. It is also possible to cut such reductions with a pipe cutter and use the compression connections mentioned above.

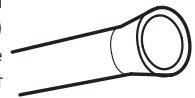

- **Bypass valve** to connect to the cold water line. The valve must have a water opening with an interior 5/32" (3,46 mm) diameter in the cold-water connection point. These valves can be located in any cold-water connection package. Before buying make sure such valve meets local standards and requirements.

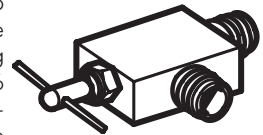

INSTALLATION INSTRUCTIONS

Install the valve to the pipe that you use to drink water. (Connect only to a potable water source).

⚠ CAUTION: Connect to potable water supply only.

1. CLOSE THE MAIN WATER SOURCE

Open the nearest water faucet to let water flow and empty pipes.

2. SELECT THE LOCATION OF THE VALVE

Select the location of the valve that will provide a better access. It is best to connect to a vertical pipeline. When connecting to a horizontal pipeline is necessary, make the connection in the lateral or upper area instead of the lower area to prevent accumulation of sediment.

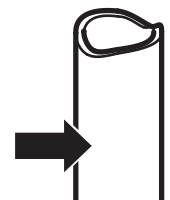

CONNECTING THE WATER LINE

3. DRILL A HOLE FOR THE VALVE

Drill a 1/4" (6,35 mm) diameter hole in the water pipeline. Remove jagged edges produced after perforation. Make sure water does not reach the drill. Not performing the 1/4" (6,35 mm) perforation can lead to a low or smaller ice production.

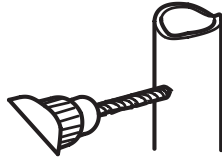

4. TIGHTEN THE VALVE

Tight the valve into the cold water pipeline with a tube trap.

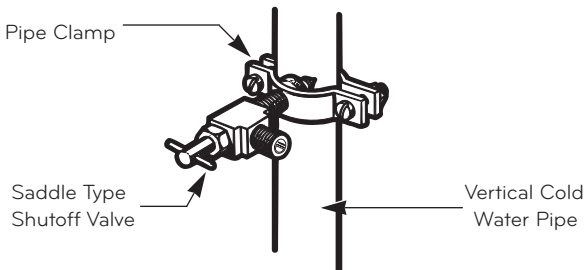

NOTE: Codes for 248 CMR pipelines of the state of Massachusetts must be attached to the connection. Valves of this type are banned in Massachusetts. Call an authorized plumber.

5. TIGHTEN THE TRAP

Tighten the trap until the sealing ring begins to grow.

NOTE: Make sure it is not too tight, this can break the pipe.

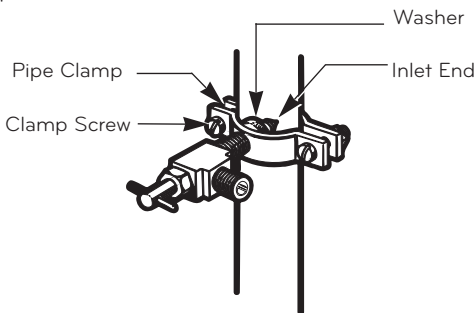

6. PLACE THE PIPELINE

Place the pipeline between the cold water pipe and the refrigerator. Place it through a hole in the wall or floor (behind the refrigerator or next to the cabinet) as close to the wall as possible.

NOTE: Make sure there is a sufficient amount of extra pipeline (8 feet [244 mm] coiled up three times with a 10" [25 cm] in diameter) to allow free movement of the refrigerator from the wall after installation was made.

7. CONNECT PIPELINE TO VALVE

Place the compression nut and the copper pipe ferule at the end of the pipe and connect to the valve. Make sure

the pipe is completely inserted into the valve. Tighten nut carefully.

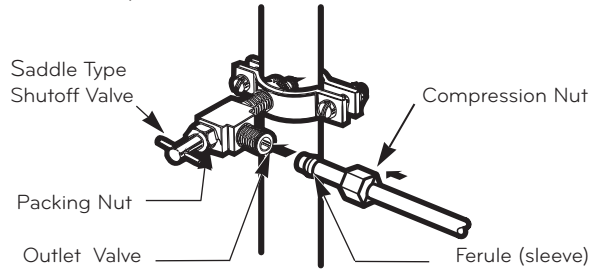

NOTE: Codes for 248 CMR pipelines of the state of Massachusetts must be attached to the connection. Valves of this type are banned in Massachusetts. Call an authorized plumber.

8. DRAIN THE PIPE

Open the main water source (1) and drain the pipe until water comes out clear.

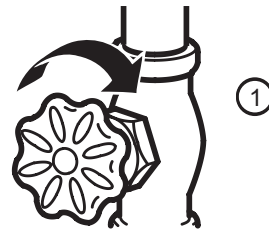

Allow water flow from the bypass valve (2) and close after draining 1/4 of a gallon (1L) of water.

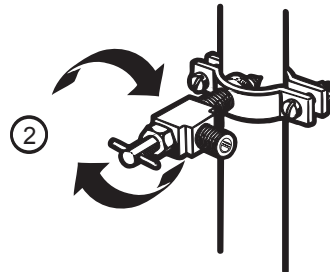

9. CONNECT PIPE TO REFRIGERATOR

NOTES:

- Before making connection to refrigerator, make sure it is not connected to any energy source. If your refrigerator does not have a water filter, it is advised to install one.
- If your water source contains sand or related particles that can travel to the valve, install a water filter near the refrigerator.

IMPORTANT: Never use old or used hoses. Always use new ones to have a better use and experience. Connect always to a potable water source to avoid security and health issues.

CONNECTING THE WATER LINE

- Remove the ring plug (1) from the valve located at the top of such device.

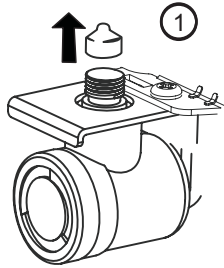

12. TURN ICE MAKER ON

Turn ice maker switch into the **ON** position. Ice maker will start only after reaching its operating temperature of 15 °F (-9 °C) or less. It will automatically begin the ice production if switch is located in the **ON** position.

- Place compression nut and the ferule at the end of the pipeline. Insert pipeline into the connection valve as far as possible. Hold tightly while holding pipeline.

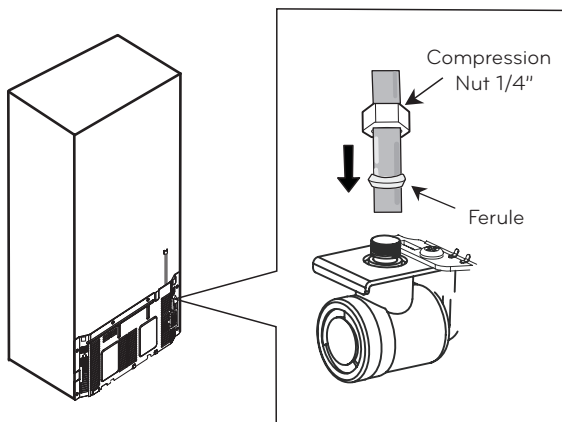

Hold on to the pipe from the handles or grabbers located behind the refrigerator, losing first the bolt holding the handle. Afterwards, insert pipe into the hole and tighten bolt to finalize.

10. OPEN THE BYPASS VALVE

Tighten all connections containing leaks. Place access cover back on compressor.

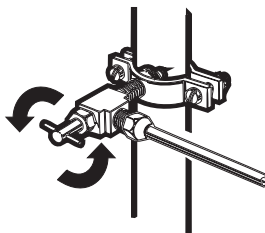

11. CONNECT TO REFRIGERATOR

Fix pipeline in a way that it does not vibrate on the refrigerator or wall. Push refrigerator against wall.

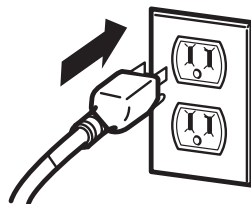



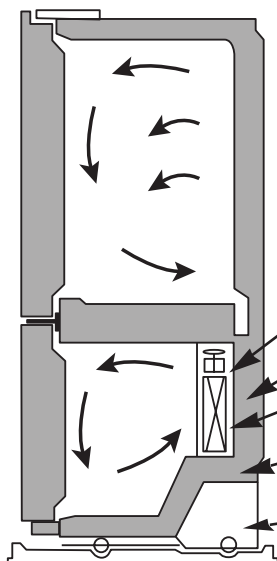

TROUBLESHOOTING GUIDE

UNDERSTANDING SOUNDS YOU MAY HEAR

Your new refrigerator might produce certain noises that your previous refrigerator did not. It is normal if you worry. Most of the new sounds you will be hearing are actually normal and expected. Hard surfaces like walls or floor can increase sounds and make them sound louder than they really are. The following list has a description of such sounds along with their causes.



- You will hear a bell sound caused by the flow of the refrigerant, water pipe or objects located on the superior part of the refrigerator.
- Your refrigerator is designed to work efficiently to preserve your food at the desired temperature using the least of energy. You will be able to hear a pulsing sound coming from the ventilators and the evaporator. The speed of the ventilator can speed up when you open the refrigerator door.
- After each cycle you will hear a dripping sound due to the refrigerant liquid in your refrigerator.
- Contraction and expansion of the inner walls can cause a slight popping sound.
- You will hear a dripping sound caused during the thawing cycle.
- During the defrosting cycle the water might cause a dripping sound.
- You can hear some tight air sound over the capacitor caused by the fan.
- Running water can be heard during the defrosting cycle.
- Due to its low energy consumption design of the refrigerator; the fans will remain off, while the on-off switch activated the internal light of bin.
- The thawing timer will make a "click" sound when such timer will start and finish. Temperature controlling device will also make a "click" sound at the beginning and ending of the refrigerator cycle.

Problem	Possible Causes	Solutions
THE REFRIGERATOR WON'T TURN ON	<ul style="list-style-type: none"> • The plug is correctly positioned. • A fuse has gone bad or the circuit presents failures. • The refrigerator is in the defrosting cycle. 	<ul style="list-style-type: none"> • Firmly plug the cord into a live outlet with proper voltage. • Replace the fuse or reset the circuit breaker. • Wait about 30 minutes for defrost cycle to end.
THE CONTROL PANEL LIGHTS ARE BLINKING SEQUENTIALLY. (1-2-3-4-5-6-7) OR THE DISPLAY SHOWS THE WORD "OFF"	<ul style="list-style-type: none"> • Refrigerator is in Demo Mode. (Demonstration Mode) <p style="text-align: center;">Type 1</p>  <p style="text-align: center;">Type 2</p> 	<ul style="list-style-type: none"> • The Demonstration Mode disables the cooling system; only the lamps and display work normally. • Type 1: To disable press ULTRA ICE  and Adjust Temp > buttons at the same time for 5 seconds. • Type 2: To disable press OFF  of the cold buttons for 5 seconds.
THE LIGHT WON'T TURN ON	<ul style="list-style-type: none"> • The refrigerator is plugged. • The light bulbs are loose. • A light bulb has gone bad. 	<ul style="list-style-type: none"> • Plug the refrigerator in a right voltage plug. • Unplug the refrigerator. Unscrew the Light bulb and screw it again (Read the section Refrigerator Care and Cleaning). Plug again. • Unplug the refrigerator before changing the light bulb. Replace the bulb with a same 40 watts bulb for your local store. (Read the section Replacing Refrigerator Lights).

TROUBLESHOOTING GUIDE

Problem	Possible Causes	Solutions
STRANGE SOUNDS OR SNOOZING/ VIBRATIONS	<ul style="list-style-type: none"> The refrigerator is not correctly positioned. 	<ul style="list-style-type: none"> You need to adjust the leveling screws due the floor is unlevelled or weak. Read the Installation section.
IT LOOKS LIKE THE COMPRESSOR MOTOR STAYS ON TOO LONG	<ul style="list-style-type: none"> The replaced refrigerator was an older model. The room temperature is hotter than usual. The door is being opened very often or there has been a big amount of food in storage. The refrigerator is plugged and the control has been adjusted correctly. Doors won't close correctly. The condenser pipes are dirty. 	<ul style="list-style-type: none"> Modern refrigerators with a bigger storage capacity require longer periods of operation. The motor will continue working when the room temperature is high. The motor might be on between 40% or 80% of the time. In high temperature conditions, the capacitor might run on periods of time. When adding or opening the door of the refrigerator, it warms it up. It's normal that the refrigerator to run more than usual in order to cool the bins. (Read the section Food Storage Guide). To save energy, take what you need at once, order your food in order so it can be easily found and close the door immediately soon after you took out the food. The refrigerator will take 24 hours to cool down completely. Push firmly the Doors. If they don't close. Read Doors will not close completely below. This will stop the air transfer and marked the motor to work longer and harder. Clean the pipes of the condenser.
DOORS WILL NOT CLOSE COMPLETELY	<ul style="list-style-type: none"> The refrigerator is not leveled. The food packages are blocking the doors. The ice bin, the vegetable bin, the panels and the shelves from the door are out of place or position. The gaskets are sticking. The refrigerator wobbles or looks instable. The doors were removed during the installation and they weren't properly setup. 	<ul style="list-style-type: none"> Read Refrigerator Installation section to level refrigerator. Adjust the food bins in order to free space between the doors and the shelves. Push the containers and place the vegetable cover lid, the panels, shelves and any other container or bin in their right positions. Read the section Using your Refrigerator. Clean the seal rings and the surface they might be in contact with. Use a piece of cloth with a small amount of paraffin and apply it over the seal rings. Level the refrigerator. Read the section Closing and Aligning the Doors. Remove and place again the door according to the section Refrigerator Doors: How to remove and reverse.
THERE'S ICE ON THE FOOD	<ul style="list-style-type: none"> The door hasn't been closed completely. The door is frequently opened. 	<ul style="list-style-type: none"> Read Doors Will not Close Completely already mentioned. When the door is opened, warm, humid air is allowed in the freezer resulting in frost.
THERE IS A WEIRD TASTE AND SMELL IN THE ICE	<ul style="list-style-type: none"> The ice maker has been installed correctly. The ice has been on storage too long. The food hasn't been packed in the correct way. The water supply contains mineral and sulfur. The inside of the refrigerator need cleaning. The ice bin needs cleaning. 	<ul style="list-style-type: none"> Don't use the first ices made. Dispose of that old ice and make new. Pack again the food because it can transfer odors and tastes to the ice. You might need to install a filter in order to eliminate the odors and taste problems. Read the section Refrigerator Care and Cleaning. Empty the bin and discard the old ice cubes.

TROUBLESHOOTING GUIDE

Problem	Possible Causes	Solutions
THERE'S WATER IN THE DRAINING BIN	<ul style="list-style-type: none"> The refrigerator is in defrosting cycle. It's more humid than usual. 	<ul style="list-style-type: none"> The water will evaporate. It is normal that some water falls on the bin. It might take a while for the water to evaporate. This is normal when the weather is hot and humid.
THE REFRIGERATOR SEEMS TO MAKE TOO MUCH NOISE	<ul style="list-style-type: none"> The sounds may be normal for your refrigerator. 	<ul style="list-style-type: none"> Refer to the Understanding Sounds You May Hear section.
THE ICE MAKER IS NOT PRODUCING ICE OR ICE CUBES ARE FREEZING TOO SLOWLY	<ul style="list-style-type: none"> The smallest size of ice cubes is selected. Door left open. 	<ul style="list-style-type: none"> Wait 24 hours after hook-up for ice production. See the Adjusting the Controls section. Check to see if something is holding the door open.
THE ICE CUBES ARE TOO SMALL	<ul style="list-style-type: none"> Smaller cube size level is selected. The water supply valve is blocked. 	<ul style="list-style-type: none"> Select a bigger size for the ice cubes. Call a plumber to clean the valve.
THE DOORS ARE HARD TO OPEN	<ul style="list-style-type: none"> The gaskets are dirty or sticky. The door opens itself as soon as you close it. 	<ul style="list-style-type: none"> Clean the gaskets and surface that they are in contact with. Use a damp cloth with paraffin also apply over the seal rings. When you open the door, the warm air enters in the refrigerator. When this air is cooled down it occupies less volume and creates a vacuum effect. If it is difficult to open wait 5 minutes then check.
THE ICE MAKER DOES NOT WORK	<ul style="list-style-type: none"> The ice maker is off. The water supply is down or not plugged. The freezer temperature is warm. The ice cubes turn off the ice maker. 	<ul style="list-style-type: none"> Turn the ice maker to the position on (I). Read the section Connecting the Water Line. Wait 24 hrs for the freezer to reach its ideal temperature. Hand level the ice cubes.
THE TEMPERATURE IS TOO HOT OR THERE'S HUMIDITY FORMED INSIDE THE REFRIGERATOR	<ul style="list-style-type: none"> The air vents are blocked. The cool air flows from freezer to the refrigerator and returns thru the vents that dive this section. The doors open very easily. The refrigerator control has not been adjusted for the room conditions. A large amount of food is just been placed inside the refrigerator. The food has not been well packed in each bin. The doors haven't been closed correctly. The weather is humid. The auto-defrosting cycle is over. 	<ul style="list-style-type: none"> With your hand find the vents and move and package that might be blocking the air flow. See the Multi Flow Section. When the doors are opened the warm and humid air enters. To keep your refrigerator cool, take what you need once and you're your food organized to make it easy to find. Close the door a soon as you can. Wait 24 hours to stabilize the temperature. If the temperature is cold or hot, move the control until the desire temperature is reached. After adding food to the refrigerator this will warm up. It might take some hours for the refrigerator to reach its temperature. Wrap the food evenly and before packing anything dry all the bins to avoid humidity. If it is necessary, pack the food according to the section Food Storage Guide. Read Doors will not Close Correctly section. In humid weathers, the air contains humidity, which introduces it self if the doors are opened. It's normal that some water props get formed after the defrosting cycle is completed.



LG Customer Information Center

1-800-243-0000 USA, Consumer User
1-888-865-3026 USA, Commercial User
1-888-542-2623 CANADA

Register your Product Online!

www.lg.com