



Compact Washer Use and Care Guide

Laveuse compactes Guide d'utilisation et d'entretien

Para una versión de estas instrucciones en español, visite www.amana.com

Table of Contents

WASHER SAFETY	2
INSTALLATION REQUIREMENTS.....	3
PERMANENT INSTALLATION INSTRUCTIONS.....	6
PORTABLE INSTALLATION INSTRUCTIONS.....	10
CONTROL PANEL AND FEATURES	13
USING YOUR WASHER.....	15
WASHER MAINTENANCE	18
TROUBLESHOOTING	20
WARRANTY.....	25
ASSISTANCE OR SERVICE.....	BACK COVER

Table des matières

SÉCURITÉ DE LA LAVEUSE	26
EXIGENCES D'INSTALLATION	27
INSTRUCTIONS D'INSTALLATION PERMANENTE.....	31
INSTRUCTIONS POUR L'INSTALLATION PORTATIVE.....	35
TABLEAU DE COMMANDE ET CARACTÉRISTIQUES.....	39
UTILISATION DE LA LAVEUSE	42
ENTRETIEN DE LA LAVEUSE	45
DÉPANNAGE	48
GARANTIE	54
ASSISTANCE OU SERVICE.....	COUVERTURE ARRIÈRE



Designed to use only HE High Efficiency detergents.
Conçue pour utiliser un détergent haute efficacité seulement.

Washer Safety

Your safety and the safety of others are very important.

We have provided many important safety messages in this manual and on your appliance. Always read and obey all safety messages.



This is the safety alert symbol.

This symbol alerts you to potential hazards that can kill or hurt you and others.

All safety messages will follow the safety alert symbol and either the word “DANGER” or “WARNING.” These words mean:

! DANGER

You can be killed or seriously injured if you don't immediately follow instructions.

! WARNING

You can be killed or seriously injured if you don't follow instructions.

All safety messages will tell you what the potential hazard is, tell you how to reduce the chance of injury, and tell you what can happen if the instructions are not followed.

IMPORTANT SAFETY INSTRUCTIONS

WARNING: To reduce the risk of fire, electric shock, or injury to persons when using the washer, follow basic precautions, including the following:

- Read all instructions before using the washer.
- Do not wash articles that have been previously cleaned in, washed in, soaked in, or spotted with gasoline, dry-cleaning solvents, other flammable, or explosive substances as they give off vapors that could ignite or explode.
- Do not add gasoline, dry-cleaning solvents, or other flammable, or explosive substances to the wash water. These substances give off vapors that could ignite or explode.
- Under certain conditions, hydrogen gas may be produced in a hot water system that has not been used for 2 weeks or more. **HYDROGEN GAS IS EXPLOSIVE.** If the hot water system has not been used for such a period, before using the washing machine, turn on all hot water faucets and let the water flow from each for several minutes. This will release any accumulated hydrogen gas. As the gas is flammable, do not smoke or use an open flame during this time.
- Do not allow children to play on or in the washer. Close supervision of children is necessary when the washer is used near children.
- Before the washer is removed from service or discarded, remove the door or lid.
- Do not reach into the washer if the drum, tub or agitator is moving.
- Do not install or store the washer where it will be exposed to the weather.
- Do not tamper with controls.
- Do not repair or replace any part of the washer or attempt any servicing unless specifically recommended in this manual or in published user-repair instructions that you understand and have the skills to carry out.
- See “Electrical Requirements” located in the installation instructions for grounding instructions.

SAVE THESE INSTRUCTIONS

State of California Proposition 65 Warnings:

WARNING: This product contains one or more chemicals known to the State of California to cause cancer.

WARNING: This product contains one or more chemicals known to the State of California to cause birth defects or other reproductive harm.

Installation Requirements

Tools and Parts

Gather the required tools and parts before starting installation. The parts supplied are in the washer basket.

Portable Installation

Parts supplied:

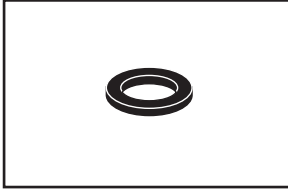

Flat washers for faucet adapter and fill hoses

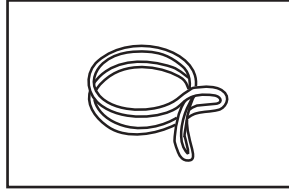

Silver, double-wire hose clamp (for bottom of drain hose)

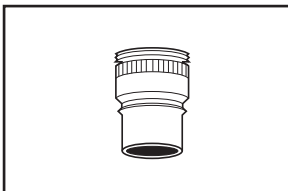

Faucet adapter

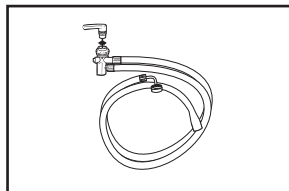

Fill-and-drain hose

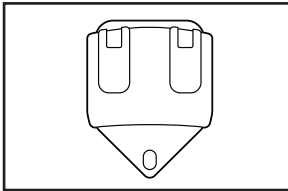

Hose bracket

Tools needed for installation:

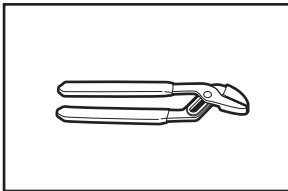

Pliers that open to 1/16" (3.95 cm)

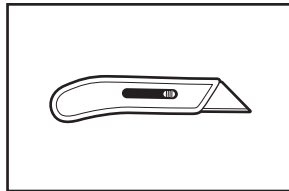

Utility knife

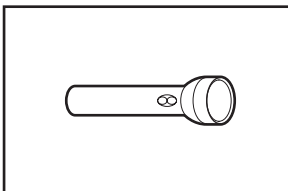

Flashlight (optional)

Permanent Installation

Parts needed (not provided with washer):

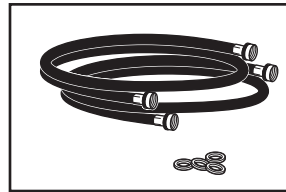

Inlet hoses with flat washers

NOTE: Replace inlet hoses after 5 years of use to reduce the risk of hose failure. Record hose installation or replacement dates for future reference.

Parts supplied:

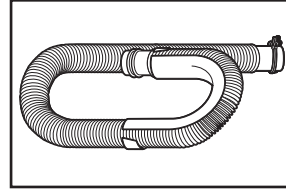

Drain hose with clamp

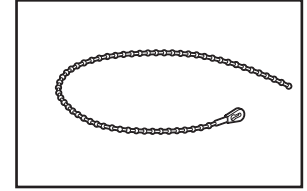

Cable tie

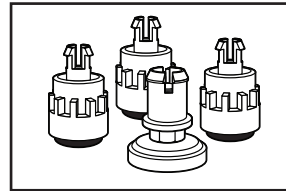

Leveling feet (4)

Tools needed for installation

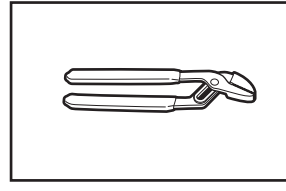

Pliers that open to 1/16" (3.95 cm)

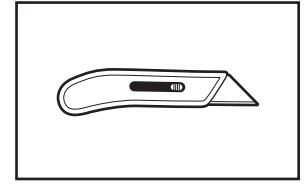

Utility knife

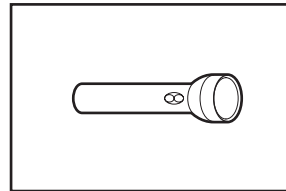

Flashlight (optional)

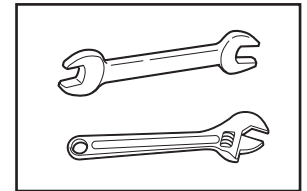

Adjustable or open-end wrench 9/16" (14 mm)

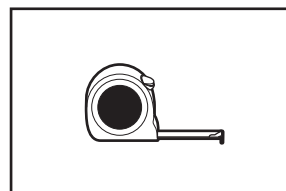

Measuring tape

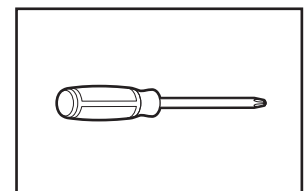

Phillips screwdriver

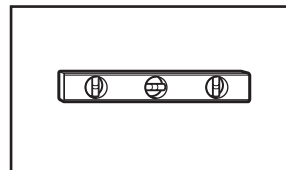

Level

Alternate Parts

Your installation may require additional parts. For information on ordering, please refer to “Assistance or Service” on the back cover of this manual.

If You Have:	You Will Need to Buy:
Laundry tub or standpipe taller than 72" (183 cm)	Sump pump system (if not already available)
1" (2.5 cm) diameter standpipe	2" (5 cm) diameter to 1" (2.5 cm) diameter standpipe adapter, Part Number 3363920
Overhead sewer	Standard 20 gal (76 L) 39" (99 cm) tall drain tub or utility sink, sump pump, and connectors (available from local plumbing suppliers)
Floor drain	Siphon break, Part Number 285320; additional drain hose, Part Number 3357090 and connector kit, Part Number 285442
Water faucets beyond reach of fill hoses	2 longer water fill hoses: 6 ft (1.8 m) Part Number 76314 10 ft (3.0 m) Part Number 350008
Drain hose too short	Drain hose, Part Number 388423 and hose kit, Part Number 285442
Drain hose that is too long	Hose kit, Part Number 285442
Lint clogged drain	Drain protector, Part Number 367031

Location Requirements

Selecting the proper location for your washer improves performance and minimizes noise and possible washer “walk.”

Your washer can be installed in a basement, laundry room, closet, or recessed area. See “Drain System.”

Washer Dimensions

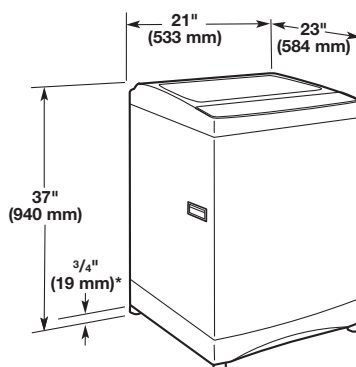

*Minimum measurement with leveling feet installed.

IMPORTANT: Do not install or store the washer where it will be exposed to the weather.

Proper installation is your responsibility.

You will need:

- A water heater set to deliver 120°F (49°C) water to the washer.
- A grounded electrical outlet located within 5 ft (1.5 m) of where the power cord is attached to the back of the washer. See “Electrical Requirements.”
- Hot and cold water faucets located within 3½ ft (1.1 m) of the hot and cold water fill valves, and water pressure of 5–100 psi (34.5–690 kPa).
- A level floor with a maximum slope of ¾" (1.9 cm) under entire washer. Installing the washer on carpeting is not recommended.
- A sturdy floor to support the washer weight (washer, water, and load) of 225 lbs (102 kg).

Do not store or operate your washer in temperatures at or below 32°F (0°C). Some water can remain in the washer and can cause damage in low temperatures. See “Washer Care” for winterizing information.

Recessed area or closet installation

The dimensions shown are for the recommended spacing allowed, except the closet door ventilation openings. The dimensions shown for the closet door ventilation openings are the minimum required.

- Additional spacing should be considered for ease of installation and servicing.
- Additional clearances may be required for wall, door, and floor moldings.
- Additional spacing of 1" (2.5 cm) on all sides of the washer is recommended to reduce noise transfer.
- If a closet door is installed, the minimum air openings in the top and bottom of the door are required. Louvered doors with air openings in the top and bottom are acceptable.
- Companion appliance spacing should also be considered.

Washer Only

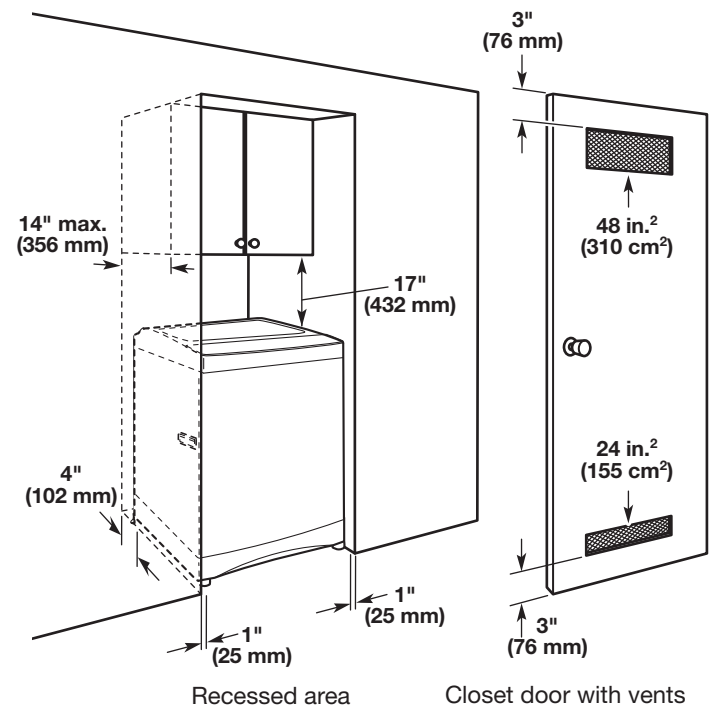

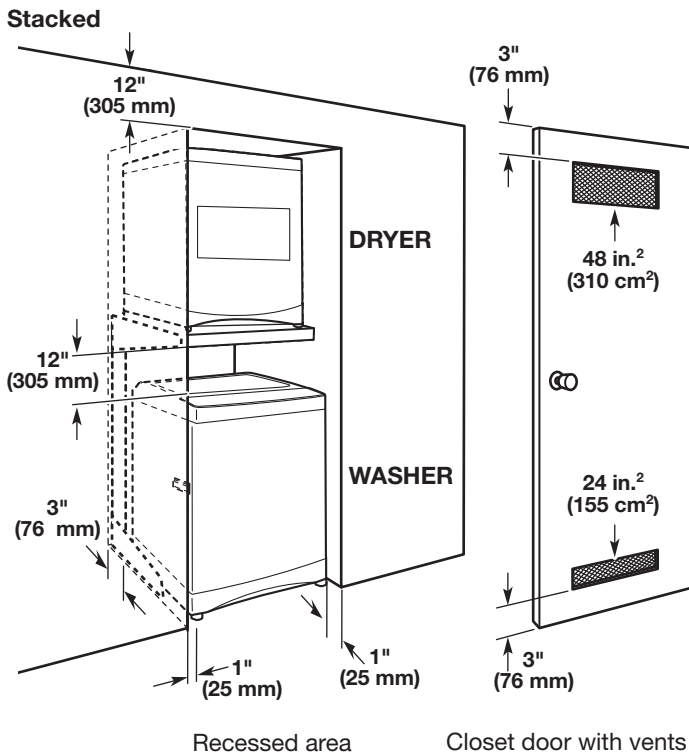

- Check with a qualified electrician if you are not sure if the washer is properly grounded.
- Do not have a fuse in the neutral or ground circuit.

GROUNDING INSTRUCTIONS

For a grounded, cord-connected washer:

This washer must be grounded. In the event of a malfunction or breakdown, grounding will reduce the risk of electrical shock by providing a path of least resistance for electric current. This washer is equipped with a cord having an equipment-grounding conductor and a grounding plug. The plug must be plugged into an appropriate outlet that is properly installed and grounded in accordance with all local codes and ordinances.

WARNING: Improper connection of the equipment-grounding conductor can result in a risk of electric shock. Check with a qualified electrician or serviceman if you are in doubt as to whether the appliance is properly grounded.

Do not modify the plug provided with the appliance – if it will not fit the outlet, have a proper outlet installed by a qualified electrician.

For a permanently connected washer:

This washer must be connected to a grounded metal, permanent wiring system, or an equipment grounding conductor must be run with the circuit conductors and connected to the equipment-grounding terminal or lead on the appliance.

Electrical Requirements

⚠ WARNING



Electrical Shock Hazard

- Plug into a grounded 3 prong outlet.
- Do not remove ground prong.
- Do not use an adapter.
- Do not use an extension cord.
- Failure to follow these instructions can result in death, fire, or electrical shock.

- A 120-volt, 60 Hz, AC-only, 15- or 20-amp, fused electrical supply is required. A time-delay fuse or circuit breaker is recommended. It is recommended that a separate circuit serving only this appliance be provided.
- This washer is equipped with a power supply cord having a 3 prong grounding plug.
- To minimize possible shock hazard, the cord must be plugged into a mating, 3 prong, grounding-type outlet, grounded in accordance with local codes and ordinances. If a mating outlet is not available, it is the personal responsibility and obligation of the customer to have the properly grounded outlet installed by a qualified electrician.
- If codes permit and a separate ground wire is used, it is recommended that a qualified electrician determine that the ground path is adequate.
- Do not ground to a gas pipe.

Remove Shipping Material

Before you install your washer, remove all shipping material.

⚠ WARNING

Excessive Weight Hazard

- Use two or more people to move and install washer.
- Failure to do so can result in back or other injury.

To avoid damaging floor, use a large flat piece of cardboard from the washer carton. Place cardboard under entire back of the washer.

Firmly grasp the body of the washer and gently lay it on the corner posts.

Remove plastic foam packaging from underneath the washer. Stand the washer up.

Remove tape from washer lid. Open washer lid and remove foam shipping piece, parts bag, and hoses from washer basket. Close the lid.

Drain System

The washer can be installed using the standpipe drain system (floor or wall), the laundry tub drain system, or the floor drain system. Select the drain hose installation method you need. See "Tools and Parts."

Standpipe drain system – wall or floor (views A & B)

The standpipe drain requires a minimum diameter standpipe of 2" (50 mm). The minimum carry-away capacity (for permanent installations) can be no less than 17 gal (64.5 L) per minute. A 2" (50 mm) diameter to 1" (25 mm) diameter standpipe adapter kit is available. See "Tools and Parts."

The top of the standpipe must be at least 39" (990 mm) high and no higher than 72" (183 cm) from the bottom of the washer.

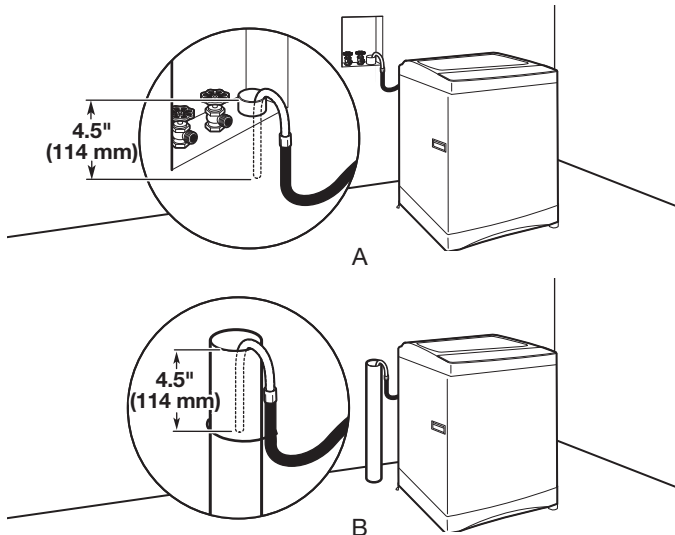

Laundry tub drain system (view C)

The laundry tub requires a minimum carry-away capacity of 17 gal (64.5 L) per minute (for permanent installations).

The top of the laundry tub must be at least 39" (990 mm) above the floor and no higher than 72" (183 cm) from the bottom of the washer.

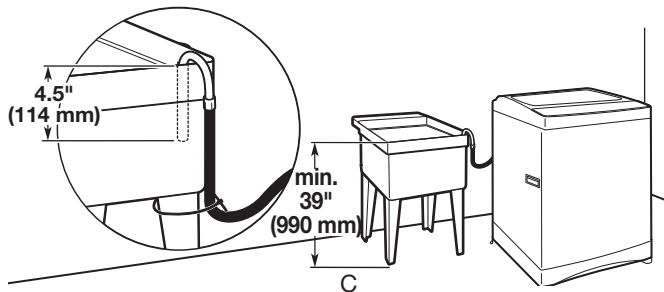

Floor drain system (view D)

The floor drain system requires a siphon break that may be purchased separately. See "Tools and Parts."

The siphon break must be a minimum of 28" (710 mm) from the bottom of the washer. Additional hoses might be needed.

The minimum carry-away capacity (for permanent installations) can be no less than 17 gal (64.5 L) per minute.

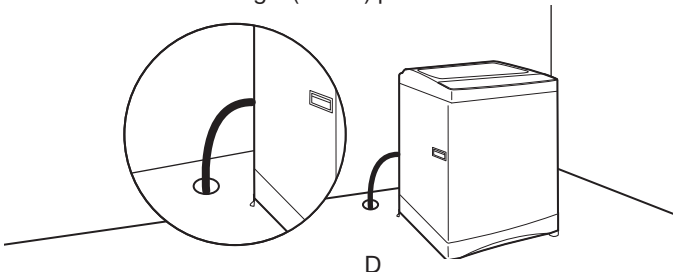

Permanent Installation Instructions

⚠ WARNING

Excessive Weight Hazard

**Use two or more people to move and install washer.
Failure to do so can result in back or other injury.**

- To avoid damage to the floor, set the washer onto cardboard before moving across floor.
- Move the washer to within approximately 3 ft (900 mm) of the final location.

Connect Drain Hose

1. Attach drain hose to drain port

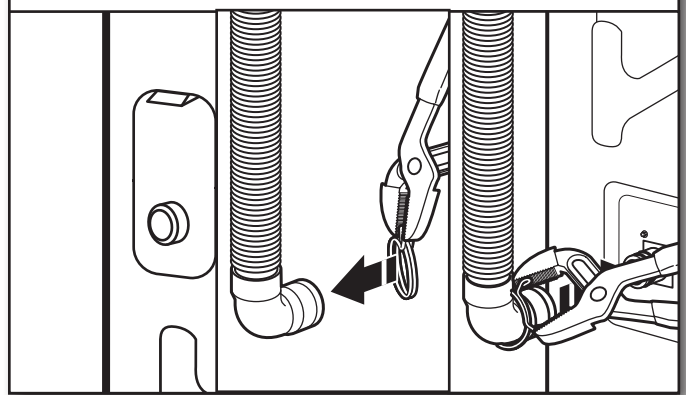

If clamp is not already in place on elbow end of drain hose, slide it over end as shown. Squeeze clamp with pliers and slide black elbow end of drain hose onto black drain port and secure with clamp.

For a laundry tub or standpipe drain, go to Step 2.

For a floor drain, remove the preinstalled drain hose form as shown in Step 3. You may need additional parts with separate directions. See "Tools and Parts."

Install Drain Hose

2. Place drain hose in standpipe

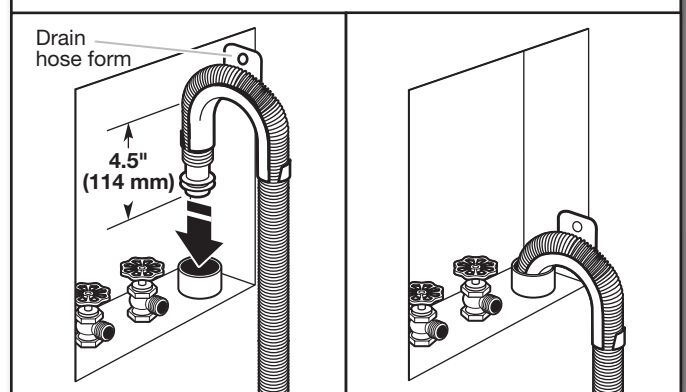

Place hose into standpipe (shown in picture) or over side of laundry tub.

IMPORTANT: 4.5" (114 mm) of drain hose should be inside standpipe; do not force excess hose into standpipe or lay on bottom of laundry tub. Drain hose form must be used.

3. Remove drain hose form (floor drain installations only)

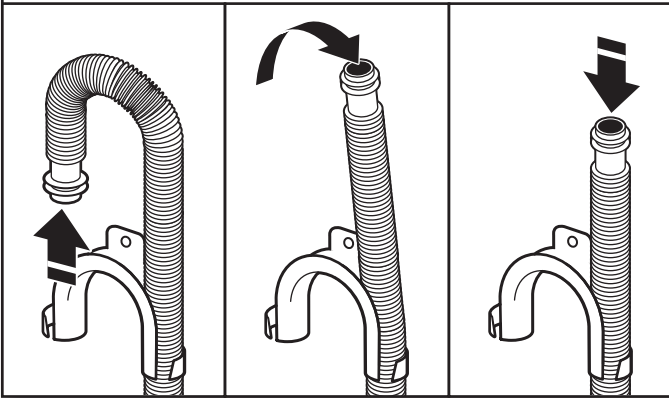

For floor drain installations, you will need to remove the drain hose form from the end of the drain hose. You may need additional parts with separate directions. See “Tools and Parts.”

Connect Inlet Hoses

The washer must be connected to the water faucets using new inlet hoses (not provided). Do not use old hoses.

4. Insert new flat washers into inlet hoses

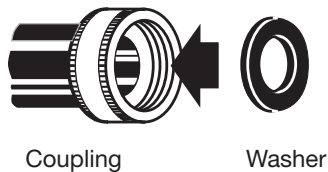

Coupling

Washer

Insert new flat washers (not provided) into each end of the inlet hoses. Firmly seat the washers in the couplings.

5. Connect inlet hoses to water faucets

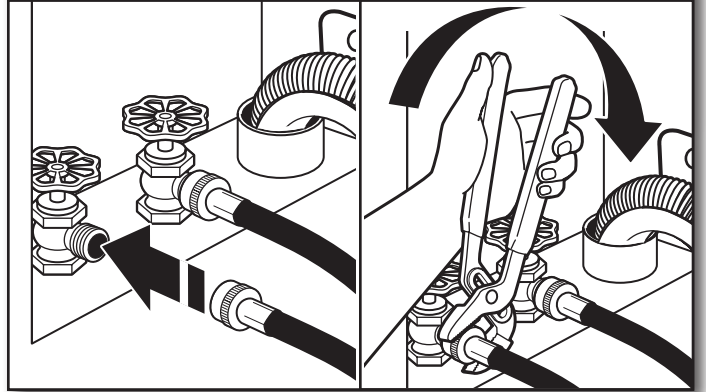

Check that the washer basket is empty.

Attach hose to hot water faucet. Screw on coupling by hand until it is seated on washer. Use pliers to tighten couplings an additional two-thirds turn. Repeat this step with second hose for cold water faucet.

IMPORTANT: Do not overtighten or use tape or sealants on valve when attaching to faucets or washer. Damage can result.

6. Clear water lines

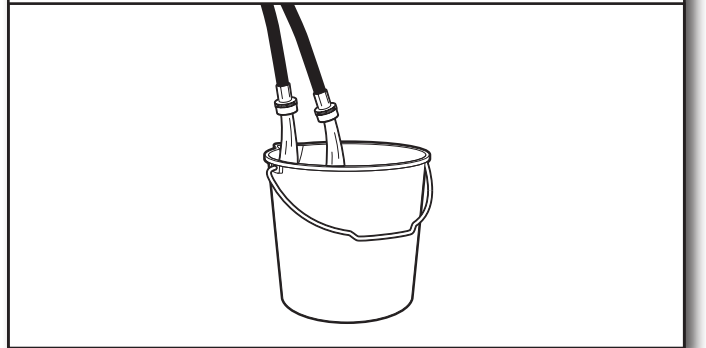

Run water for a few seconds through hoses into a laundry tub, drainpipe, or bucket to avoid clogs. Water should run until clear.

Make note of which hose is connected to hot water to help in attaching hoses to washer correctly.

7. Connect inlet hoses to washer

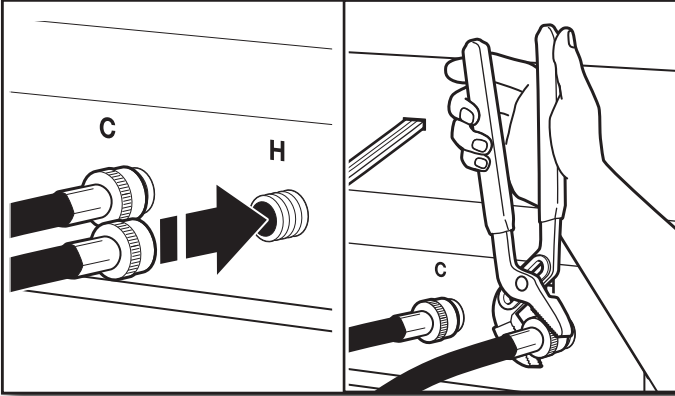

Remove inlet cap and attach hot water hose to hot water (right) inlet valve. Screw coupling by hand until it is snug. Use pliers to tighten couplings an additional two-thirds turn. Repeat with cold water (left) inlet valve.

IMPORTANT: To reduce risk of hose failure, replace the hoses every 5 years. Record hose installation or replacement dates for future reference.

- Periodically inspect and replace hoses if bulges, kinks, cuts, wear, or leaks are found.

8. Check for leaks

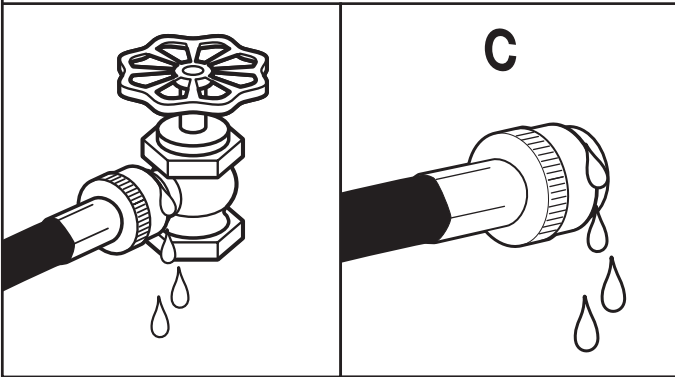

Turn on water faucets to check for leaks. A small amount of water may enter washer. It will drain later.

- If you connect only one water hose, you must cap (supplied) off the remaining water inlet port.

Secure Drain Hose

9. Secure drain hose to laundry tub, standpipe, or wall

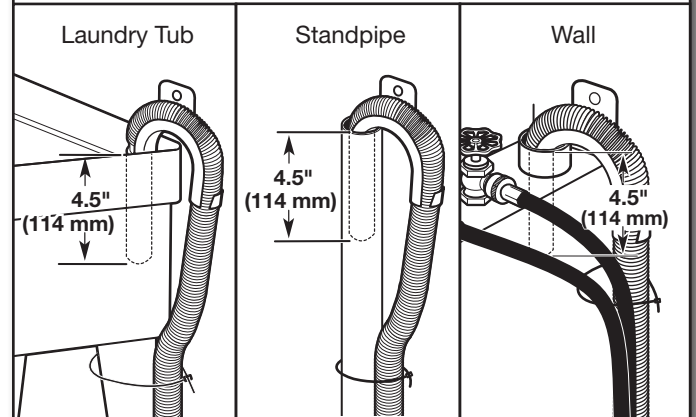

Secure drain hose to laundry tub leg, drain standpipe, or inlet hoses for wall standpipe with cable tie (provided).

- Do not force excess drain hose back into the rear of the washer.
- To avoid siphoning, do not seal or put more than 4½" (114 mm) of the drain hose into drainpipe or standpipe.

Install Leveling Feet – Optional (for permanent installation only)

IMPORTANT: Installation of the leveling feet is permanent. Once the leveling feet are installed into the base of the washer they cannot be removed.

⚠ WARNING

Excessive Weight Hazard

Use two or more people to move and install washer.
Failure to do so can result in back or other injury.

10. Install leveling feet

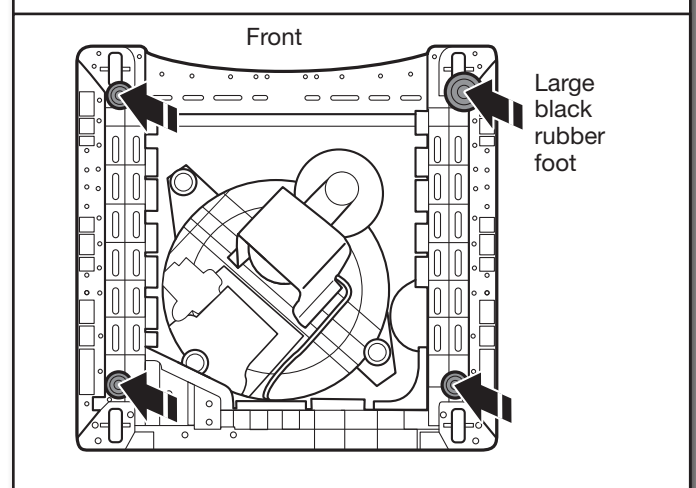

Lay washer on its back. Push in to snap the large black rubber foot into the right front corner of the washer base. Repeat to install the remaining leveling feet on the other 3 corners.

Level the Washer

IMPORTANT: Level washer properly to reduce excess noise and vibration.

For Permanent Installations:

11. Check levelness of washer

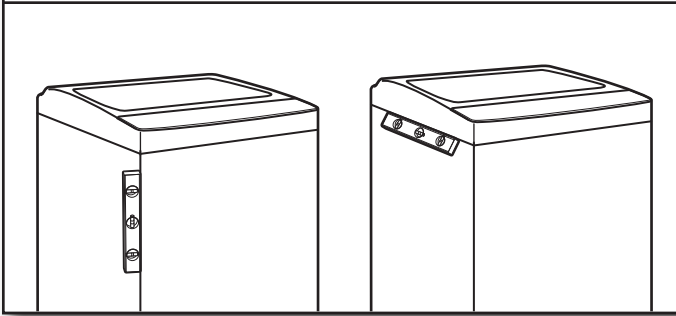

Move the washer to its final location. Place a level on top edges of washer. Use side seam as a guide to check levelness of sides. Check levelness of front using lid, as shown. Rock washer back and forth to make sure all 4 feet make solid contact with floor.

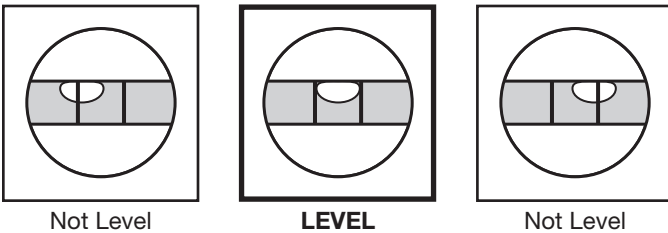

12. Adjust leveling foot

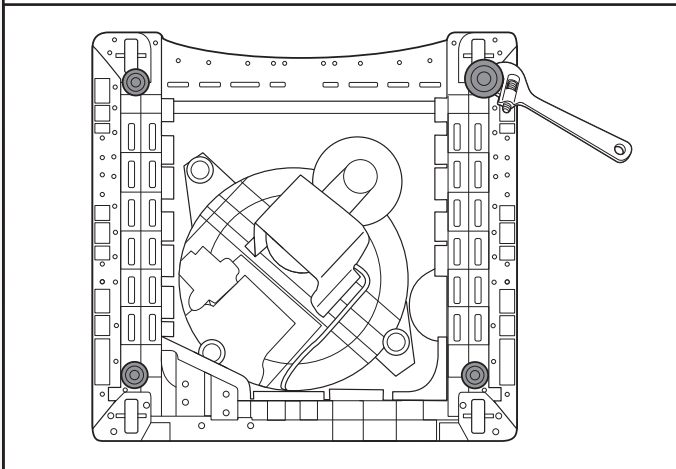

If the washer is not level, lay washer on its back to adjust the large black rubber leveling foot. If the washer is against a wall, move the washer out slightly before laying on its back.

Use a crescent wrench to adjust the large black rubber leveling foot up or down as necessary.

NOTE: The 3 smaller leveling feet are not adjustable.

For Portable Installations:

Check the levelness of the floor.

⚠ WARNING



Electrical Shock Hazard

Plug into a grounded 3 prong outlet.

Do not remove ground prong.

Do not use an adapter.

Do not use an extension cord.

Failure to follow these instructions can result in death, fire, or electrical shock.

13. Plug into a grounded 3 prong outlet

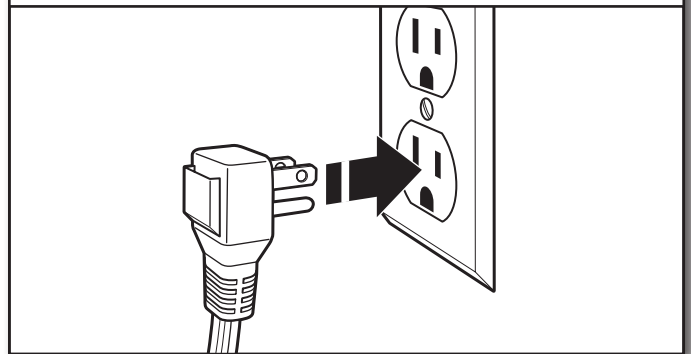

Complete Installation Checklist

- Check electrical requirements. Be sure you have correct electrical supply and recommended grounding method.
- Check that all parts are now installed. If there is an extra part, go back through steps to see what was skipped.
- Check that you have all of your tools.
- Check that shipping materials were completely removed from washer.
- Check that water faucets are on.
- Check for leaks around faucets and inlet hoses.
- Remove protective film from console and any tape remaining on washer.
- Check that washer is plugged into a grounded 3 prong outlet.
- Dispose of/recycle all packaging materials.
- Read "Washer Care" in your Use and Care Guide.
- To test and clean your washer, measure $\frac{1}{2}$ of normal recommended amount of powdered or liquid detergent and pour it into washer basket or detergent dispenser (on some models). Close lid. Select any cycle. Start washer and allow to complete full cycle.

Portable Installation Instructions

Drain System

The washer must drain into a sink or laundry tub with a carry-away capacity of 17 gal (64.5 L) per minute (for portable installations). The top of the tub must be at least 27" (68.6 cm) above floor and no higher than 48" (121.9 cm) from the bottom of the washer.

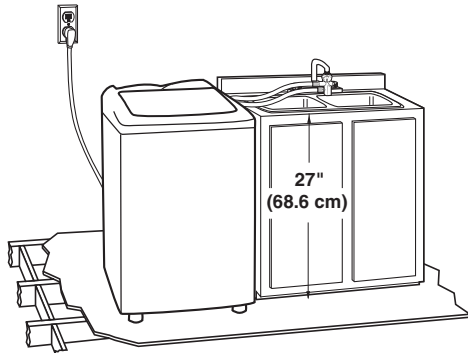

1. Attach hose bracket

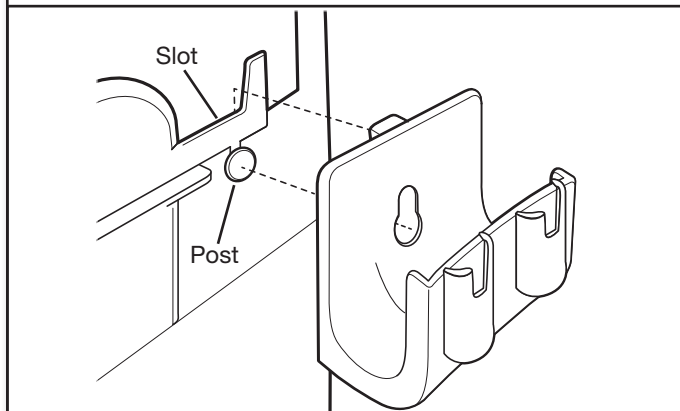

Place the hose bracket over the post on the back of the washer and position the the tab so it will insert into the slot. Push down to lock into place.

Connect Fill-And-Drain Hose

Proper connection of the fill-and-drain hose will protect your floors from damage due to water leakage.

2. Insert new flat washer into inlet hose

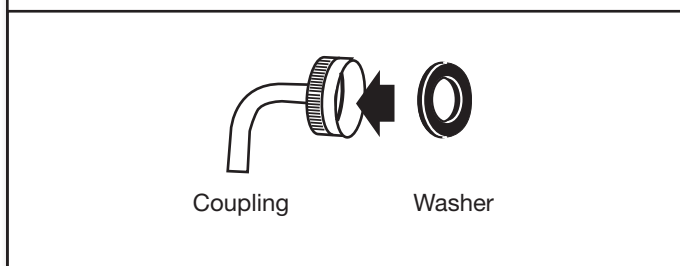

Insert new flat washer (supplied) into the end of the inlet hose. Firmly seat the washer in the coupling.

3. Connect fill hose

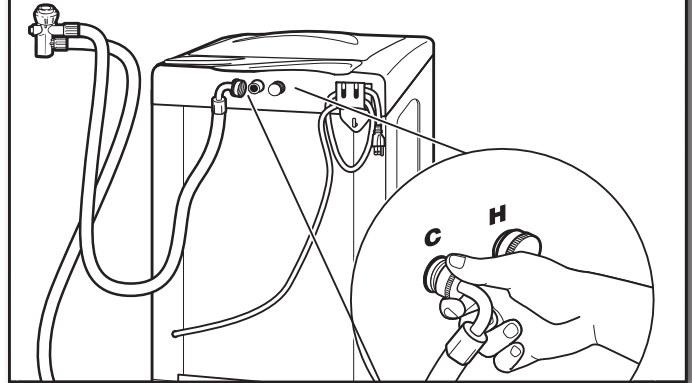

Attach the fill hose to the cold water (left) inlet valve. Tighten coupling by hand. Use pliers to make an additional two-thirds turn.

NOTE: Do not overtighten. Damage to the valves can result. Hot water (right) inlet valve is capped. Leave this valve capped.

4. Connect drain hose

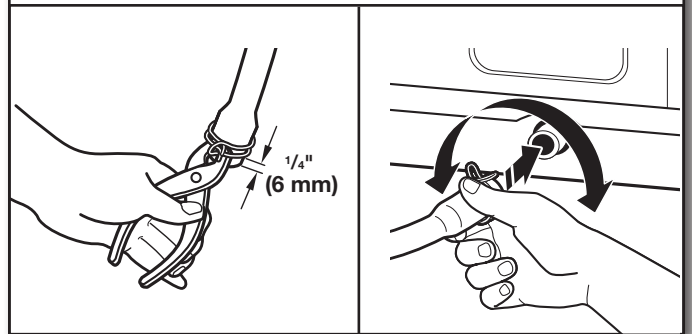

To keep the fill-and-drain hose from leaking, it must be installed according to the following instructions.

IMPORTANT: To ensure proper installation, this procedure must be followed exactly.

Remove permanent installation drain hose. Wet inside end of the drain hose with tap water.

IMPORTANT: Do not use any lubricant other than water.

Squeeze ears of double-wire clamp with pliers to open. Place clamp over the straight end of the drain hose 1/4" (6 mm) from the end. Twist hose back and forth while pushing down onto drain connector at the bottom of the washer. Continue until hose contacts the cabinet.

5. Secure drain hose

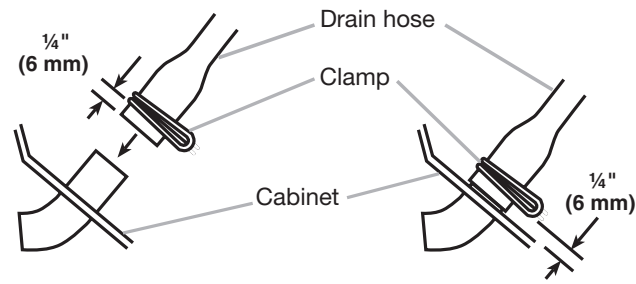

Place clamp over area marked "CLAMP." Release clamp.

6. Attach faucet kit adapter to faucet

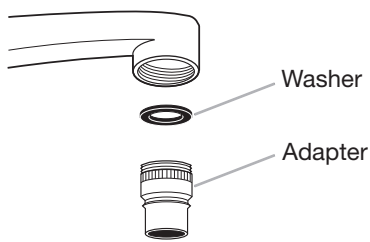

Proper connection of your faucet adapter kit will allow hot and cold water to enter your washer properly. It also helps avoid water damage due to leaks.

Attach the faucet adapter kit from the parts bag to your faucet. A standard faucet adapter and washer are supplied. Customized adapters are available from traditional plumbing supply sources.

7. Attach fill-and-drain hose connector to faucet

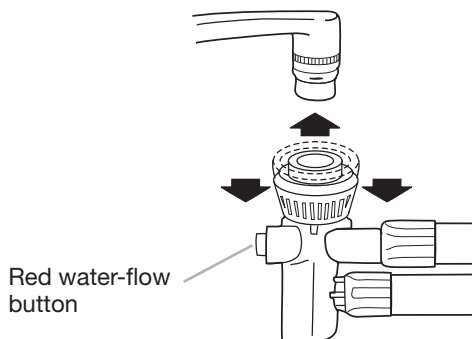

Roll washer to sink area. It rolls and operates on wheels. The wheels do not roll from side to side. Be sure your washer is on a level floor to help avoid movement during spin.

Attach fill-and-drain hose connector to a single-spout hot/cold water faucet. Move the locking collar down while lifting the connector until it snaps into place.

8. Set wash TEMP to COLD

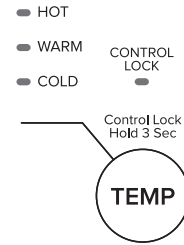

Set the temperature setting on your washer to COLD. Set the water temperature for the wash cycle by adjusting the Hot and Cold water faucets.

To test the water, press the red water-flow button on the hose connector.

NOTE: If desired, you can change the water temperature for the rinse cycle by adjusting the Hot and Cold water faucets. Keep the temperature setting on your washer set at COLD.

⚠ WARNING



Electrical Shock Hazard

Plug into a grounded 3 prong outlet.

Do not remove ground prong.

Do not use an adapter.

Do not use an extension cord.

Failure to follow these instructions can result in death, fire, or electrical shock.

9. Plug into a grounded 3 prong outlet

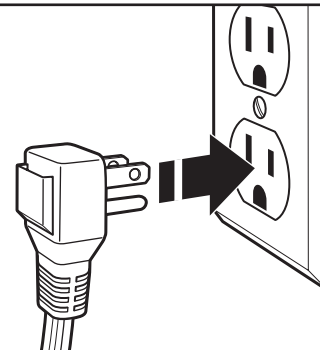

Disconnect Washer

1. Remove fill-and-drain hose connector from faucet

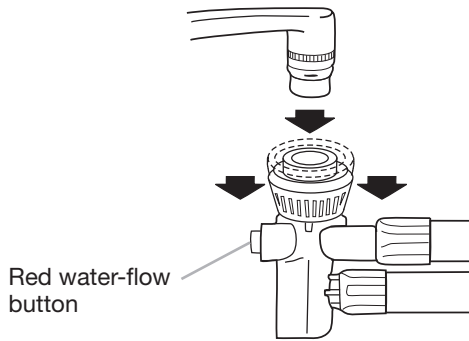

Turn off water faucets and unplug the power cord. Press the red water-flow button to release water pressure in the hose. Pull the locking collar down to remove the connector from the faucet.

2. Replace fill-and-drain hose on storage bracket

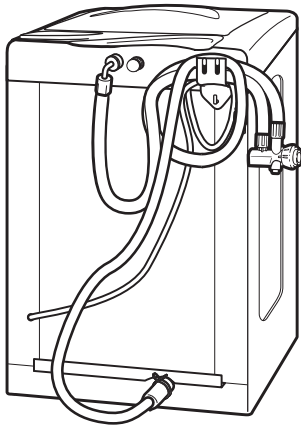

Pour water out of the faucet connector. Place fill-and-drain hose on the plastic holder in the back of the washer.

Complete Installation Checklist

- Check electrical requirements. Be sure you have correct electrical supply and recommended grounding method.
- Check that all parts are now installed. If there is an extra part, go back through steps to see what was skipped.
- Check that you have all of your tools.
- Check that shipping materials were completely removed from washer.
- Check that water faucets are on.
- Check for leaks around faucets and inlet hoses.
NOTE: If the washer is attached to a faucet equipped with a spray hose, the constant water pressure may cause the spray hose to leak. To avoid possible failure, the spray hose should be disconnected or replaced with a high-pressure hose.
- Remove protective film from console and any tape remaining on washer.
- Check that washer is plugged into a grounded 3 prong outlet.
- Dispose of/recycle all packaging materials.
- Read "Washer Care" in your Use and Care Guide.
- To test and clean your washer, measure $\frac{1}{2}$ of normal recommended amount of powdered or liquid detergent and pour it into washer basket or detergent dispenser (on some models). Close lid. Select any cycle. Start washer and allow to complete full cycle.

Control Panel and Features

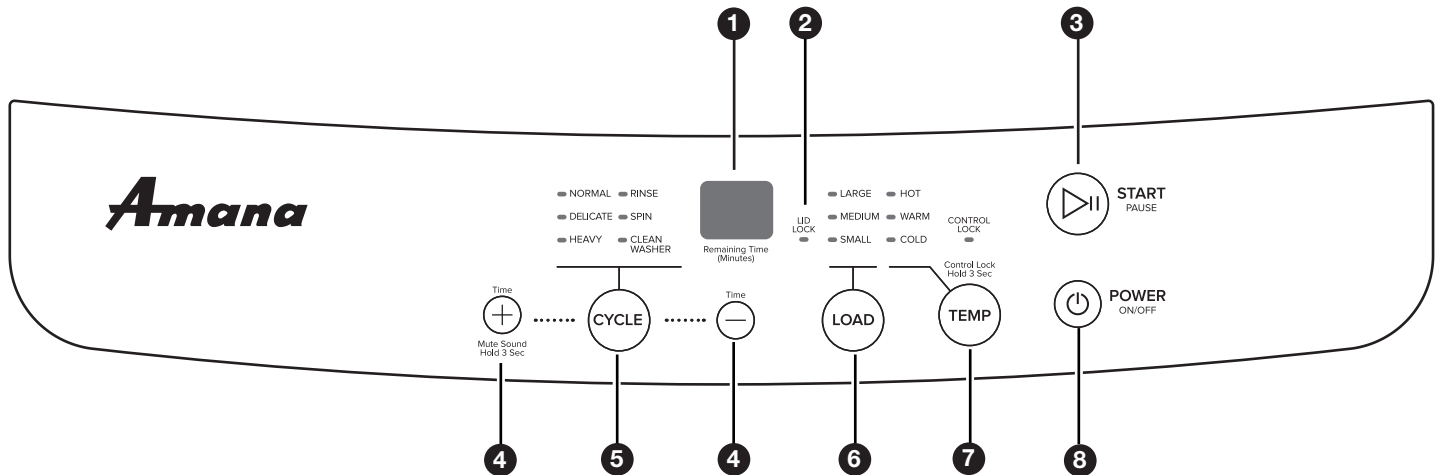

1 LED TIME/STATUS DISPLAY

The Remaining Time display shows the time required for the cycle to complete. Factors such as load size and water pressure may affect the time shown in the display. Tightly packed loads, unbalanced loads, or excessive suds may cause the washer to adjust the cycle time as well.

2 LID LOCK LIGHT

The Lid Lock indicator lights up when the lid is locked and cannot be opened. If you need to open the lid, press and hold START/PAUSE. The lid will unlock once the washer movement has stopped. This may take several minutes if the load was spinning at high speed. Press the Start/Pause button again to restart the cycle.

3 START/PAUSE

After selecting a wash cycle, press START/PAUSE to start the cycle. Press once to pause a cycle. The flashing lights indicate the selected cycle and the current process.

4 CYCLE TIME (+ or -)

- Press “+” or “-” to adjust the duration of a wash cycle.
- Press “+” or “-” to adjust the duration of a spin cycle.
- LED display will show the time remaining for the cycle to complete.
- If an out-of-range adjustment is made, a buzzer will sound.

End-of-Cycle Signal

Press and hold the plus (+) button for 3 seconds to enable or disable the end-of-cycle signal.

5 CYCLE

Press CYCLE to select a wash cycle. Choose from Normal, Delicate, Heavy, Rinse, Spin, or Clean Washer.

NOTE: The washer will remember the last cycle used, with a default load size of Medium.

6 LOAD SIZE

Press to select the water level based on the amount of garments to wash.

When the Medium water level is selected with the Normal or Heavy cycle, the washer will sense the size of the load and adjust if required.

7 TEMP

Select a wash temperature based on the type of fabric and soils being washed. For best results and following the garment label instructions, use the warmest wash water safe for your fabric.

For Portable Installations: If desired, you can change the water temperature for the rinse cycle by adjusting the Hot and Cold water faucets. Keep the temperature setting on your washer set at COLD.

CONTROL LOCK

Press and hold TEMP for 4 seconds to lock the controls. Press and hold for 4 seconds to unlock. You may still press POWER ON/OFF to turn off the washer.

8 POWER ON/OFF

Press POWER ON/OFF to turn on or off the washer. Press once while a cycle is running to stop the washer.

Dispensers

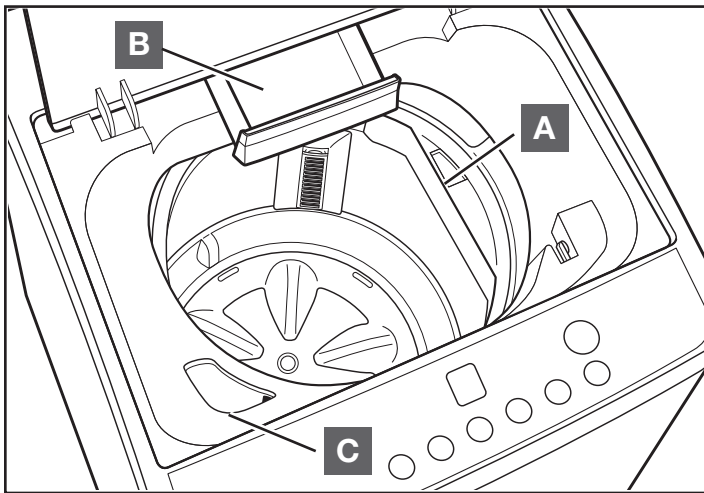

A Liquid fabric softener dispenser

Pour measured liquid fabric softener into the liquid fabric softener dispenser if desired. It will dispense automatically at the optimum time.

- Use only liquid fabric softener in this dispenser.

NOTE: The fabric softener dispenser rotates around the wash basket and may not be in the same spot each time.

B High Efficiency “HE” powdered detergent dispenser

Add only powdered HE detergent product to this dispenser for your main wash cycle.



Use only High Efficiency (HE) detergent.

NOTES:

- Follow the manufacturer’s instructions to determine the amount of detergent to use.
- Add liquid HE detergent or single-dose packets to the basket prior to adding laundry.

C Liquid chlorine bleach dispenser

This dispenser holds up to ¾ cup (180 mL) liquid chlorine bleach. The bleach will be automatically diluted and dispensed at the optimum time during the wash cycle. This dispenser cannot dilute powdered bleach.

NOTE: Fill dispenser with only liquid bleach.

Choosing the Right Detergent

Use only High Efficiency detergents. The package will be marked “HE” or “High Efficiency.” Low-water washing creates excessive sudsing with a non-HE detergent. Using non-HE detergent will likely result in longer cycle times and reduced rinsing performance. It may also result in component failure and, over time, buildup of mold or mildew. HE detergents should be low-sudsing and quick-dispersing to produce the right amount of suds for the best performance. They should hold soil in suspension so it is not re-deposited onto clean clothes. Not all detergents labeled as High Efficiency are identical in formulation and their ability to reduce suds. For example, natural, organic, or homemade HE detergents may generate a high level of suds. Follow the manufacturer’s instructions to determine the amount of detergent to use.

Cycle Guide

- NORMAL ● RINSE
- DELICATE ● SPIN
- HEAVY ● CLEAN WASHER

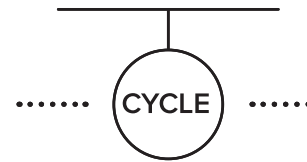

This section describes the available wash cycles and will help you make the best cycle selections for your wash loads. Each cycle is designed for different types of fabric and soil levels. Always read and follow fabric care label instructions to avoid damage to your items.

Normal

Use this cycle for normally soiled cottons and linens. Wash combines medium-speed agitation and high-speed spin to shorten drying time.

Delicate

Use this cycle for lingerie and loosely knit items. Wash combines low-speed agitation for gentle soil removal, and high-speed spin to shorten drying time.

Heavy

Use this cycle for sturdy or heavily soiled loads. Wash combines high-speed agitation and high-speed spin for maximum soil removal.

Rinse

Use this cycle for additional rinsing of the washer load or hand-washed items.

Spin

Use this cycle to remove excess water from the washer load or hand-washed items.

Clean Washer

Use this cycle every 30 washes to keep the inside of your washer fresh and clean. This cycle uses a higher water level. Use with affresh® Washer Cleaner tablet or liquid chlorine bleach to thoroughly clean the inside of your washer. This cycle should not be interrupted.

IMPORTANT: Do not place garments or other items in the washer during the Clean Washer cycle. Use this cycle with an empty washtub.

End-of-Cycle Signal

The End-of-Cycle signal may be turned on and off by pressing and holding the Cycle “+” button for 3 seconds.

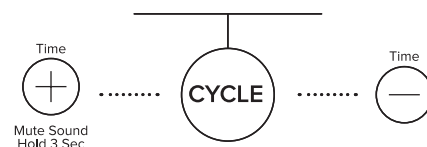

Using Your Washer

⚠ WARNING



Fire Hazard

Never place items in the washer that are dampened with gasoline or other flammable fluids.

No washer can completely remove oil.

Do not dry anything that has ever had any type of oil on it (including cooking oils).

Doing so can result in death, explosion, or fire.

⚠ WARNING



Electrical Shock Hazard

Plug into a grounded 3 prong outlet.

Do not remove ground prong.

Do not use an adapter.

Do not use an extension cord.

Failure to follow these instructions can result in death, fire, or electrical shock.

1. Sort and prepare your laundry

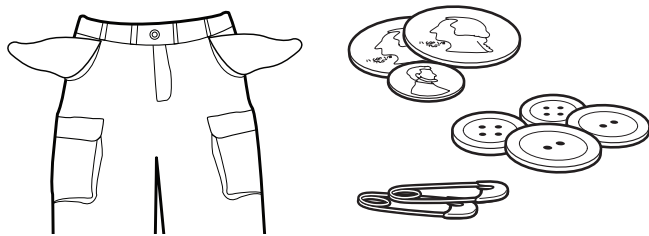

- Empty pockets. Loose change, buttons, or any small object can pass under the washplate and become trapped, causing unexpected sounds.
- Sort items by recommended cycle, water temperature, and colorfastness.
- Separate heavily soiled items from lightly soiled.
- Separate delicate items from sturdy fabrics.
- Do not dry items if stains remain after washing; heat can set stains into fabric.
- Treat stains promptly.
- Close zippers, fasten hooks, tie strings, and sashes. Remove non-washable trim and ornaments.
- Mend rips and tears to avoid further damage to items during washing.

Helpful Tips:

- For best performance, use HE liquid detergent when washing bulky items.
- Use mesh bags to help avoid tangling when washing delicate or small items.
- Turn knits inside out to avoid pilling. Separate lint-takers from lint-givers. Synthetics, knits, and corduroy fabrics will pick up lint from towels, rugs, and chenille fabrics.

NOTE: Always read and follow fabric care label instructions to avoid damage to your items.

2. Add laundry products

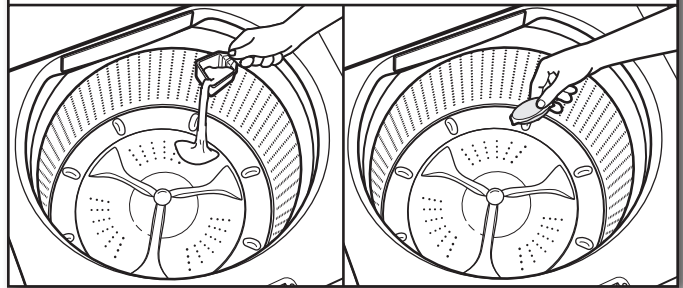

IMPORTANT: If you are using the Compact Dryer Stack Stand (Part Number 49971), pull the washer forward before lifting the washer lid.

If you are using liquid laundry detergent, single-dose laundry packets, color-safe bleach, Oxi-type boosters, or fabric softener crystals, add to the wash basket prior to adding laundry.

NOTE: Always follow manufacturer's instructions.

3. Load laundry into washer

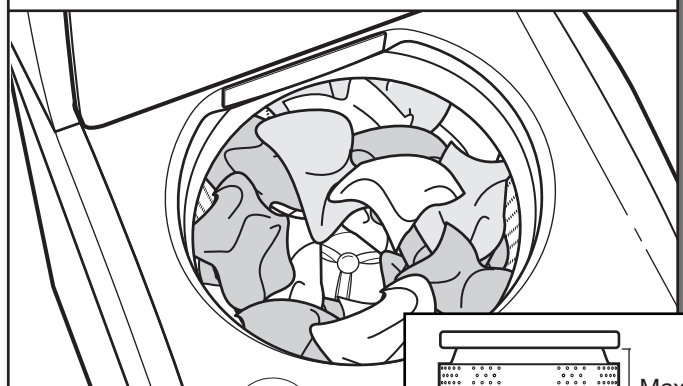

For best performance, load items in loose heaps evenly around the washplate. Try mixing different-sized items to reduce tangling.

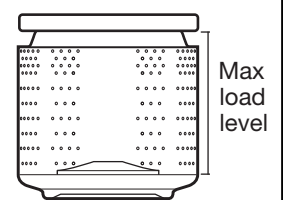

IMPORTANT: Items need to move freely for best cleaning and to reduce wrinkling and tangling.

NOTE: The maximum volume is about 1.52 cubic ft. (4.4 lb max. load size per cubic ft.).

Using Laundry Product Dispensers

NOTE: Do not add liquid laundry detergent, single-dose laundry packets, color-safe bleach, Oxi-type boosters, or fabric softener crystals to dispensers. They will not dispense correctly. Add to the basket prior to adding laundry.

4. Add powdered HE detergent

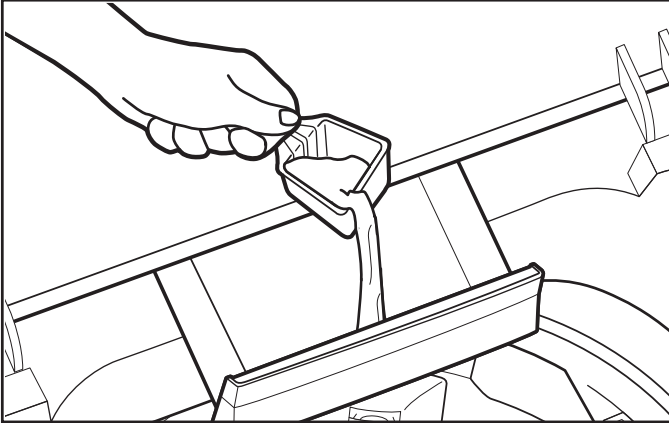

IMPORTANT: Use only High Efficiency detergents. The package will be marked “HE” or “High Efficiency.” Low-water washing creates excessive sudsing with a regular non-HE detergent. Using regular detergent will likely result in longer cycle times and reduced rinsing performance. It may also result in component failures and noticeable mold or mildew. HE detergents are made to produce the right amount of suds for the best performance. Follow the manufacturer’s instructions to determine the amount of detergent to use.

NOTES:

- Use only powdered HE detergent in the detergent dispenser. Add liquid HE detergent or single-dose packets to the basket prior to adding laundry.
- See “Washer Maintenance” for information on recommended method of cleaning washer dispensers.

5. Add liquid chlorine bleach to dispenser

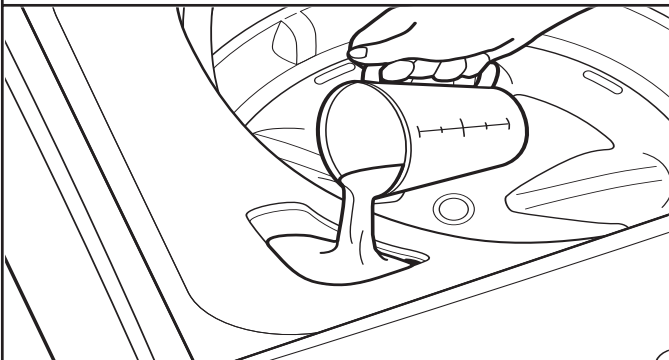

Bleach will be dispensed automatically during the wash part of the cycle. Do not overfill, dilute, or use more than 1 cup (250 mL). Do not use color-safe bleach or Oxi products in the same cycle with liquid chlorine bleach.

6. Add liquid fabric softener

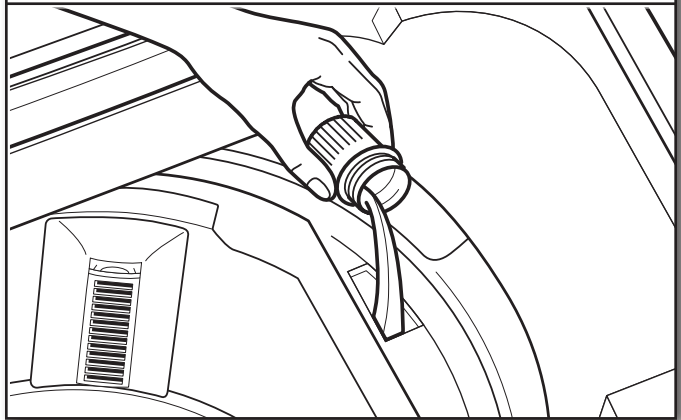

Pour a measured amount of liquid fabric softener into dispenser; always follow manufacturer’s directions for correct amount of fabric softener based on your load size. Fabric Softener is added during rinse.

IMPORTANT: Do not overfill or dilute. Overfilling dispenser will cause fabric softener to immediately dispense into washer. It is normal for a small amount of water to remain in the dispenser at the end of a cycle.

NOTE: The fabric softener dispenser rotates around the wash basket and may not be in the same spot each time.

7. Press POWER to turn on washer



Close the washer lid. Washer will not fill, agitate, or spin with the lid open. Make sure the dispenser drawer is closed completely; then press POWER to turn on the washer.

8. Select LOAD size

- LARGE
- MEDIUM
- SMALL

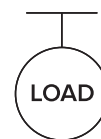

Press the Load button to select the correct setting for your wash load and the type of fabric being washed. Choose a water level that allows the load to move freely for best fabric care.

When Medium is selected with the Normal or Heavy cycles, the washer will sense the size of the load and adjust if required.

You may change the load size setting while the washer is filling. If you change from Large to Medium but the water has filled past Medium, you will get Medium with the next fill.

9. Select wash TEMP

● HOT
● WARM
● COLD

CONTROL LOCK
●

Control Lock Hold 3 Sec

TEMP

Set the water temperature for the type of fabric and soils being washed. Use the warmest wash water safe for fabric. Follow garment label instructions.

For Portable Installations

Open the faucets connected to the water supply hoses. Wash and Rinse water temperatures are set at your faucet. The Temperature control does not set the temperature. Adjust the Hot and Cold water faucets to desired wash temperature. Keep the temperature control set at COLD.

NOTE: The Cold setting allows water from the faucet to enter the washer, but does not control the incoming water temperature.

For a Rinse temperature that is different from the wash temperature, you must adjust the water temperature at the faucet after the washer has completed its initial fill.

To test the water temperature, press the red water-flow button on the hose connector.

For Permanent Installations

The Rinse and Spin cycles default to a cold rinse, all other cycles default to a warm rinse. Press the Temp button to choose a different wash temperature.

Selecting Water Temperatures

NOTE: Always read and follow fabric care labels instructions to avoid damage to your items.

Water Temperature	Suggested Fabrics
Hot	Whites and pastels Durable items Heavy soils
Warm	Bright colors Moderate to light soils
Cold	Colors that bleed or fade Light soils

NOTE: In wash water temperatures colder than 60°F (15.6°C), detergents do not dissolve well. Soils can be difficult to remove. Some fabrics can retain wear wrinkles and have increased pilling (the formation of small lint-like balls on the surface of garments).

10. Select CYCLE

● NORMAL ● RINSE
● DELICATE ● SPIN
● HEAVY ● CLEAN WASHER

..... CYCLE

Press the Cycle button to select your wash cycle. See “Cycle Guide” for details on cycle features.

11. Press Start/Pause button to begin wash cycle

START
PAUSE

Press the Start/Pause button to start the wash cycle. When the cycle has finished, the end-of-cycle signal will sound (if set). Promptly remove items when cycle is done to avoid odor, reduce wrinkling, and reduce rusting of metal hooks, zippers, and snaps.

Unlocking the lid to add items

If you need to open the lid to add 1 or 2 missed items:

Press the Start/Pause button to pause washer; the lid will unlock once the washer movement has stopped. This may take several minutes if the load was spinning at a high speed. Then close lid and press the Start/Pause button again to restart the cycle.

To stop or restart your washer:

- To stop the washer at any time, press the Start/Pause button and the cycle will pause.
- To restart the washer, press the Start/Pause button and the cycle will resume.

Washer Maintenance

WATER INLET HOSES

Replace inlet hoses after 5 years of use to reduce the risk of hose failure. Periodically inspect and replace inlet hoses if bulges, kinks, cuts, wear, or leaks are found.

When replacing your inlet hoses, mark the date of replacement on the label with a permanent marker.

WASHER CARE

Recommendations to Help Keep Your Washer Clean and Performing at Its Best

1. Always use High Efficiency (HE) detergents and follow the HE detergent manufacturer's instructions regarding the amount of HE detergent to use. Never use more than the recommended amount because that may increase the rate at which detergent and soil residue accumulate inside your washer which, in turn, may result in undesirable odor.
2. Use warm and hot wash water settings sometimes (not exclusively cold water washes), because they do a better job of controlling the rate at which soils and detergent accumulate.
3. Always leave the washer lid open between uses to help dry out the washer and prevent the buildup of odor-causing residue.

Cleaning Your Top Loading Washer

Read these instructions completely before beginning the routine cleaning processes recommended below. This Washer Maintenance Procedure should be performed, at a minimum, once per month or every 30 wash cycles, whichever occurs sooner, to control the rate at which soils and detergent may otherwise accumulate in your washer.

Cleaning the Inside of the Washer

To keep your washer odor-free, follow the usage instructions provided above, and use this recommended monthly cleaning procedure:

Clean Washer Cycle

This washer has a special cycle that uses higher water volumes in combination with affresh® Washer Cleaner or liquid chlorine bleach to clean the inside of the washer.

Begin procedure

1. **affresh® Washer Cleaner Cycle Procedure (Recommended for Best Performance):**
 - a. Open the washer lid and remove any clothing or items.
 - b. Place an affresh® Washer Cleaner tablet in the bottom of the washer basket.
 - c. Do not place an affresh® Washer Cleaner tablet in the detergent dispenser.
 - d. Do not add any detergent or other chemical to the washer when following this procedure.
 - e. Close the washer lid.
 - f. Select the Clean Washer cycle.
 - g. Press the Start/Pause button to begin the cycle.
The Clean Washer Cycle Operation is described below.

NOTE: For best results, do not interrupt cycle. If cycle must be interrupted, press POWER. (For models with no Power/Cancel button, press and hold START/PAUSE for three seconds). After the Clean Washer cycle has stopped, run a Rinse cycle to rinse cleaner from washer.

WASHER CARE (cont.)

Begin procedure

2. Chlorine Bleach Procedure (Alternative):

- a. Open the washer lid and remove any clothing or items.
- b. Add 1 cup (236 mL) of liquid chlorine bleach to the bleach compartment.

NOTE: Use of more liquid chlorine bleach than is recommended above could cause washer damage over time.

- c. Close the washer lid.
- d. Do not add any detergent or other chemical to the washer when following this procedure.
- e. Select the Clean Washer cycle.
- f. Press the Start/Pause button to begin the cycle.
The Clean Washer Cycle Operation is described below.

NOTE: For best results, do not interrupt cycle. If cycle must be interrupted, press POWER. (For models with no Power/Cancel button, press and hold START/PAUSE for 3 seconds). After the Clean Washer cycle has stopped, run a Rinse cycle to rinse cleaner from washer.

Description of Clean Washer Cycle Operation:

1. This cycle will fill to a water level higher than in normal wash cycles to provide rinsing at a level above the water line for normal wash cycle.
2. During this cycle, there will be some agitation and spinning to increase the removal of soils.

After this cycle is complete, leave the lid open to allow for better ventilation and drying of the washer interior.

Cleaning the Dispensers

After a period of using your washer, you may find some residue buildup in the washer's dispensers. To remove residue from the dispensers, wipe them with a damp cloth and towel dry. Do not attempt to remove the dispensers or trim for cleaning. The dispensers and trim are not removable. If your model has a dispenser drawer, however, remove the drawer and clean it before or after you run the Clean Washer cycle. Use an all-purpose surface cleaner, if needed.

Cleaning the Outside of the Washer

Use a soft, damp cloth or sponge to wipe away any spills. Use only mild soaps or cleaners when cleaning external washer surfaces.

IMPORTANT: To avoid damaging the washer's finish, do not use abrasive products.

WASHER CARE (cont.)

Cleaning The Lint Filter

Clean filter after every load.

1. Press down, then out, to remove the lint filter.

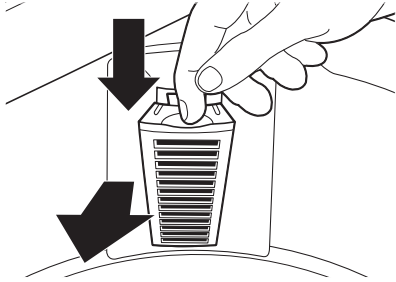

2. Open the lint filter and clean with water.

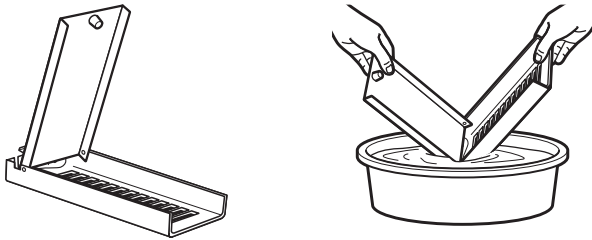

3. Insert the lint filter bottom first; then press down and in to replace the filter.

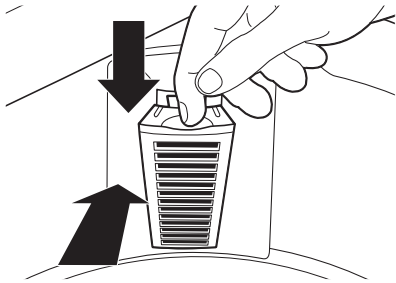

TRANSPORTING YOUR WASHER

1. Shut off both water faucets. Disconnect and drain water inlet hoses.
2. If washer will be moved during freezing weather, follow "Winter Storage Care" directions before moving.
3. Disconnect drain hose from drain system and from back of washer.
4. Unplug power cord.
5. Place inlet hoses and drain hose inside washer basket.
6. Bundle power cord with a rubber band or cable tie to keep it from hanging onto the ground.

IMPORTANT: Call for service to install new transport bolts. Do not reuse transport bolts. Washer must be transported in the upright position. To avoid structural damage to your washer, it must be properly set up for relocation by a certified technician.

NON-USE AND VACATION CARE

Operate your washer only when you are home. If moving, or not using your washer for a period of time, follow these steps:

1. Unplug or disconnect power to washer.
2. Turn off water supply to washer to avoid flooding due to water pressure surges.
3. Clean the dispensers. See "Cleaning the Dispensers."

WINTER STORAGE CARE

IMPORTANT: To avoid damage, install and store washer where it will not freeze. Because some water may stay in hoses, freezing can damage washer. If storing or moving during freezing weather, winterize your washer.

To winterize washer:

1. Shut off both water faucets, disconnect and drain water inlet hoses.
2. Put 1 qt (1 L) of R.V.-type antifreeze in washer basket and run washer on Normal cycle for about 2 minutes to mix antifreeze and remaining water.
3. Unplug washer or disconnect power.

REINSTALLING/USING WASHER AGAIN

To reinstall washer after non-use, vacation, winter storage, or moving:

1. Refer to Installation Instructions to locate, level, and connect washer.
2. Before using again, run washer through the following recommended procedure:

To use washer again:

1. Flush water pipes and hoses. Reconnect water inlet hoses. Turn on both water faucets.

⚠ WARNING



Electrical Shock Hazard

Plug into a grounded 3 prong outlet.

Do not remove ground prong.

Do not use an adapter.

Do not use an extension cord.

Failure to follow these instructions can result in death, fire, or electrical shock.

2. Plug in washer or reconnect power.
3. Run washer through Heavy Duty cycle to clean washer and remove antifreeze, if used. Use only HE detergent. Use half the manufacturer's recommended amount for a medium-size load.

Troubleshooting

First try the solutions suggested here or visit our website at www.amana.com –
In Canada www.amanacanada.ca for assistance and to possibly avoid a service call.

If you experience	Possible Causes	Solution
Vibration or Off-Balance		
Vibration, rocking, or “walking”	Feet may not be in contact with the floor and locked.	Front and rear feet or casters must be in firm contact with floor, and washer must be level to operate properly.
	Washer may not be level.	Check floor for flexing or sagging. If flooring is uneven, a ¾" (19 mm) piece of plywood under your washer will reduce sound. See “Level the Washer” in the Installation Instructions.
Vibration during spinning or washer stopped	Load could be unbalanced.	Load items in loose heaps evenly around the washplate. Adding wet items to washer or adding more water to basket could unbalance washer.
		Avoid washing single items. Balance a single item such as a rug or jeans jacket with a few extra items. Redistribute the load, close the lid, and press START/PAUSE.
		Item or load not suitable for selected cycle. See “Cycle Guide” and “Using Your Washer.”
Noises		
Clicking or metallic noises	Objects may be caught in washer drain system.	Empty pockets before washing. Loose items such as coins could fall between basket and tub or may block pump. It may be necessary to call for service to remove items.
		It is normal to hear metal items on clothing such as metal snaps, buckles, or zippers touch against the stainless steel basket.
Gurgling or humming	Washer may be draining water.	It is normal to hear the pump making a continuous humming sound with periodic gurgling or surging as final amounts of water are removed during the spin/drain cycles.
Humming	Load sensing may be occurring.	You may hear the hum of the sensing spins after you have started the washer. This is normal.
Whirring	Basket may be slowing down.	You may hear the whirring sound of the basket slowing down. This is normal.
Water Leaks		
Check the following for proper installation:	Washer not level.	Water may splash off basket if washer is not level.
	Fill hoses not attached tightly.	Tighten fill-hose connection.
	Fill hose washers	Make sure fill hose flat washers are properly seated.
	Drain hose connection	Properly secure drain hose to drainpipe or laundry tub.
		Do not place tape over drain opening.
	Check household plumbing for leaks or clogged sink or drain.	Water can back up out of a clogged sink or drainpipe. Check all household plumbing for leaks (laundry tubs, drain pipe, water pipes, and faucets.)
Washer not loaded as recommended.	An unbalanced load can cause basket to be out of alignment and cause water to splash off tub. See “Using Your Washer” for loading instructions.	
Washer not performing as expected		
Not enough water in washer	Load not completely covered in water.	This is normal operation for an HE low-water washer. The load will not be completely underwater. The washer senses load sizes and adds correct amount of water for optimal cleaning. IMPORTANT: Do not add more water to washer. Adding water lifts the items off the washplate, resulting in less effective cleaning.
		Run Clean Washer cycle to optimize the water level and wash performance.

Troubleshooting

First try the solutions suggested here or visit our website at www.amana.com –
In Canada www.amanacanada.ca for assistance and to possibly avoid a service call.

If you experience	Possible Causes	Solution
Washer not performing as expected (cont.)		
Washer won't run or fill, washer stops working	Check for proper water supply.	Hose(s) must be attached and have water flowing to inlet valve.
		Water faucet(s) must be turned on.
		Check that inlet valve screens have not become clogged.
		Check for any kinks in inlet hoses, which can restrict water flow.

⚠ WARNING



Electrical Shock Hazard

Plug into a grounded 3 prong outlet.

Do not remove ground prong.

Do not use an adapter.

Do not use an extension cord.

Failure to follow these instructions can result in death, fire, or electrical shock.

Washer won't run or fill, washer stops working (cont.)	Check proper electrical supply.	Plug power cord into a grounded 3-prong outlet.
		Do not use an extension cord.
		Ensure there is power to outlet.
		Reset a tripped circuit breaker. Replace any blown fuses. NOTE: If problems continue, contact an electrician.
	Normal washer operation.	Lid must be closed for washer to run.
		Washer will pause during certain phases of cycle. Do not interrupt cycle.
		Washer may be stopped to reduce suds.
	Washer may be tightly packed.	Remove several items, rearrange load evenly around the washplate. Close lid, press Start/Pause button.
Add only 1 or 2 additional items after washer has started.		
Do not add more water to the washer.		
Not using HE detergent or using too much HE detergent.	Only use HE detergent. Suds from regular detergents can slow or stop the washer. Always measure detergent and follow detergent directions based on your load requirements.	
	To remove suds, cancel cycle. Select RINSE then SPIN. Do not add more detergent.	
Washer not draining/spinning, loads are still wet	Small items may have been caught in pump or between basket and tub, which can slow draining.	Empty pockets and use garment bags for small items.
	Using cycles with a lower spin speed.	Cycles with lower spin speeds remove less water than cycles with high spin speeds. Use the recommended cycle/speed spin for your item.
	Washer may be tightly packed or unbalanced.	Tightly packed loads may not allow the washer to spin correctly, leaving the load wetter than normal. Evenly arrange the wet load for balanced spinning. Select SPIN to remove excess water. See "Using Your Washer" for loading recommendations.

Troubleshooting

First try the solutions suggested here or visit our website at www.amana.com –
In Canada www.amanacanada.ca for assistance and to possibly avoid a service call.

If you experience	Possible Causes	Solution
Washer not performing as expected (cont.)		
Washer not draining/spinning, loads are still wet (cont.)	Load off balanced.	See “Vibration or Off-Balance” in “Troubleshooting” section for more information.
	Check plumbing for correct drain hose installation. Drain hose extends into standpipe farther than 4.5" (114 mm).	Check drain hose for proper installation. Use drain hose form and securely attach to drainpipe or tub. Do not tape over drain opening. Lower drain hose if the end is higher than 96" (2.4 m) above the floor. Remove any clogs from drain hose.
	Not using HE detergent or using too much HE detergent.	Suds from regular detergent or using too much detergent can slow or stop draining or spinning. Use only HE detergent. Always measure and follow detergent directions for your load. To remove extra suds, select RINSE. Do not add detergent.
Incorrect or wrong wash or rinse temperatures	Check for proper water supply.	For permanent installations, make sure that hot and cold inlet hoses are not reversed. For portable installations, adjust water temperature at faucet.
		For permanent installations, both hoses must be attached to both washer and faucet, and have both hot and cold water flowing to inlet valve.
		Check that inlet valve screens are not clogged.
		Remove any kinks in hoses.
Load not rinsed	Check for proper water supply.	For permanent installations, make sure hot and cold inlet hoses are not reversed.
		Hoses must be attached and have water flowing to the inlet valves or faucet.
		For permanent installations, both hot and cold water faucets must be on. For portable installations, sink faucet must be on.
		Inlet valve screens on washer may be clogged.
		Remove any kinks in the inlet hose.
	Not using HE detergent or using too much HE detergent.	The suds from regular detergent can cause the washer to operate incorrectly.
		Use only HE detergent. Be sure to measure correctly.
		Always measure detergent and follow detergent directions based on load size and soil level.
	Washer may be tightly packed.	The washer is less efficient at rinsing when load is tightly packed.
		Load items in loose heaps evenly around the washplate.
Use cycle designed for the fabrics being washed.		
Add only 1 or 2 additional items after washer has started.		
Sand, pet hair, lint, etc. on load after washing	Heavy sand, pet hair, lint, and detergent or bleach residues may require additional rinsing.	Run an additional Rinse cycle.
Load is tangling	Washer not loaded as recommended.	Load items in loose heaps evenly around the washplate. Reduce tangling by mixing types of load items. Use the recommended cycle for the type of items being washed.
	Wash action and/or spin speed too fast for load.	Select a cycle with a slower wash action and slower spin speed. Note that items will be wetter than when using a higher speed spin.
Not cleaning or removing stains	Wash load not completely covered in water.	Washer senses load size and adds correct amount of water. This is normal and necessary for clothes to move.
	Added more water to washer.	Do not add more water to washer. Adding water lifts the items off the washplate, resulting in less effective cleaning.
	Washer not loaded as recommended.	Load items in loose heaps evenly around the washplate.
Add only 1 or 2 additional items after washer has started.		

Troubleshooting

First try the solutions suggested here or visit our website at www.amana.com –
In Canada www.amanacanada.ca for assistance and to possibly avoid a service call.

If you experience	Possible Causes	Solution
Washer not performing as expected (cont.)		
Not cleaning or removing stains (cont.)	Not using HE detergent or using too much HE detergent.	The suds from regular detergent can keep washer from operating correctly.
		Use only HE detergent. Be sure to measure correctly.
		Always measure detergent and follow detergent directions based on load size and soil level.
	Not using correct cycle for fabric type.	Use a higher soil level cycle option and warmer wash temperature to improve cleaning.
		Use Heavy cycle for tough cleaning.
		See the “Cycle Guide” to match your load with the best cycle.
	Not using dispensers.	Use dispensers to avoid chlorine bleach and fabric softener staining.
		Load dispensers before starting a cycle.
		Avoid overfilling.
		Do not add products directly onto load.
Not washing like colors together.	Wash like colors together and remove promptly after the cycle is complete to avoid dye transfer.	
Odors	Monthly maintenance not done as recommended.	Run the Clean Washer cycle after every 30 washes. See “Washer Care.”
		Unload washer as soon as cycle is complete.
	Not using HE detergent or using too much HE detergent.	Use only HE detergent. Be sure to measure correctly.
		Always follow the detergent directions.
See “Washer Care” section.		
Fabric damage	Sharp items were in pockets during wash cycle.	Empty pockets, zip zippers, and snap or hook fasteners before washing to avoid snags and tears.
	Strings and straps could have tangled.	Tie all strings and straps before starting wash load.
	Items may have been damaged before washing.	Mend rips and broken threads in seams before washing.
	Fabric damage can occur if the load is tightly packed.	Load items in loose heaps evenly around washplate.
		Load items should move freely during wash cycle to avoid damage.
		Use cycle designed for the fabrics being washed.
		Add only 1 or 2 additional items after washer has started.
	Garment care instructions may not have been followed.	Always read and follow garment manufacturer’s care label instructions. See the “Cycle Guide” to match your load with the best cycle.
	Liquid chlorine bleach may have been added incorrectly.	Do not pour liquid chlorine bleach directly onto load. Wipe up bleach spills.
		Undiluted bleach will damage fabrics. Do not use more than recommended by manufacturer.
Do not place load items on top of bleach dispenser when loading and unloading washer.		

Troubleshooting

First try the solutions suggested here or visit our website at www.amana.com –
In Canada www.amanacanada.ca for assistance and to possibly avoid a service call.

If you experience	Possible Causes	Solution
Washer not performing as expected (cont.)		
Incorrect dispenser operation	Clogged dispensers or laundry products dispensing too soon.	Do not overfill dispenser. Overfilling causes immediate dispensing.
		Load dispensers before starting a cycle.
		It is normal for small amounts of water to be remain in dispenser at the end of the cycle.
		Fabric softener thickens as it gets older. If there becomes an increase of fabric softener in the dispenser after a cycle, check the age of the fabric softener and replace if needed.
		Homes with low water pressure may result in residual powder in the dispenser. To avoid, select a warmer wash temperature if possible, depending on your load. Do not use single-dose laundry packets in the dispenser. They may not dissolve properly and clog the dispenser.
	Liquid chlorine bleach not used in dispenser.	Use only liquid chlorine bleach in the bleach dispenser.
Powdered detergent not dissolving completely in load	Using too much HE detergent.	Follow the manufacturer's instructions to determine the amount of detergent to use.
	Water temperature is very cold.	Select a warmer wash temperature.
		Try adding the detergent to the basket prior to adding laundry, rather than using the detergent dispenser.
Single-dose laundry packet not dissolving	Adding laundry packet incorrectly.	Be sure laundry packet is added to washer basket before adding clothes. Follow the manufacturer's instructions to avoid damage to your items.
Error Code Appears in Display		
E1 – Water inlet alarm	Water level not reached after 20 minutes.	Check that the water faucets are not closed.
		Check that the water pressure in the house is over 20kPa.
		Clean the inlet hose filter screens.
		Check that the drain hose is not below 27½" (700 mm) from the floor.
E2 – Draining alarm	Washer is still detecting water after draining for 8 minutes.	Check that the drain hose is not more than 39⅓" (100 cm) from the floor.
		Remove any clogs from the drain hose.
E3 – Unbalanced alarm	Washer may be tightly packed or clothes are not evenly distributed.	Remove several items, rearrange load evenly around the washplate, and restart the Spin cycle.
E4 – Open lid alarm	Opening the lid during the Spin cycle.	Close the lid.
EA or EC – Other errors	Other	Call for technical assistance – see “Assistance or Service” on the back cover.

AMANA® MAJOR APPLIANCE LIMITED WARRANTY

ATTACH YOUR RECEIPT HERE. PROOF OF PURCHASE IS REQUIRED TO OBTAIN WARRANTY SERVICE.

Please have the following information available when you call the Customer eXperience Center:

- Name, address and telephone number
- Model number and serial number
- A clear, detailed description of the problem
- Proof of purchase including dealer or retailer name and address

IF YOU NEED SERVICE:

1. Before contacting us to arrange service, please determine whether your product requires repair. Some questions can be addressed without service. Please take a few minutes to review the Troubleshooting or Problem Solver section of the Use and Care Guide, scan the QR code on the right to access additional resources, or visit <http://amana.custhelp.com>.
2. All warranty service is provided exclusively by our authorized Amana Service Providers. In the U.S. and Canada, direct all requests for warranty service to:

Amana Customer eXperience Center

In the U.S.A., call 1-800-843-0304. In Canada, call 1-800-807-6777.

If outside the 50 United States or Canada, contact your authorized Amana dealer to determine whether another warranty applies.



<http://amana.custhelp.com>

ONE YEAR LIMITED WARRANTY

WHAT IS COVERED

For one year from the date of purchase, when this major appliance is installed, operated and maintained according to instructions attached to or furnished with the product, Amana brand of Whirlpool Corporation or Whirlpool Canada LP (hereafter "Amana") will pay for Factory Specified Replacement Parts and repair labor to correct defects in materials or workmanship that existed when this major appliance was purchased, or at its sole discretion replace the product. In the event of product replacement, your appliance will be warranted for the remaining term of the original unit's warranty period.

YOUR SOLE AND EXCLUSIVE REMEDY UNDER THIS LIMITED WARRANTY SHALL BE PRODUCT REPAIR AS PROVIDED HEREIN. Service must be provided by a Amana designated service company. This limited warranty is valid only in the United States or Canada and applies only when the major appliance is used in the country in which it was purchased. This limited warranty is effective from the date of original consumer purchase. Proof of original purchase date is required to obtain service under this limited warranty.

WHAT IS NOT COVERED

1. Commercial, non-residential, multiple-family use, or use inconsistent with published user, operator or installation instructions.
2. In-home instruction on how to use your product.
3. Service to correct improper product maintenance or installation, installation not in accordance with electrical or plumbing codes or correction of household electrical or plumbing (i.e. house wiring, fuses or water inlet hoses).
4. Consumable parts (i.e. light bulbs, batteries, air or water filters, preservation solutions, etc.).
5. Defects or damage caused by the use of non-genuine Amana parts or accessories.
6. Conversion of products from natural gas or L.P. gas.
7. Damage from accident, misuse, abuse, fire, floods, acts of God or use with products not approved by Amana.
8. Repairs to parts or systems to correct product damage or defects caused by unauthorized service, alteration or modification of the appliance.
9. Cosmetic damage including scratches, dents, chips, and other damage to the appliance finishes unless such damage results from defects in materials and workmanship and is reported to Amana within 30 days.
10. Discoloration, rust or oxidation of surfaces resulting from caustic or corrosive environments including but not limited to high salt concentrations, high moisture or humidity or exposure to chemicals.
11. Food or medicine loss due to product failure.
12. Pick-up or delivery. This product is intended for in-home repair.
13. Travel or transportation expenses for service in remote locations where an authorized Amana servicer is not available.
14. Removal or reinstallation of inaccessible appliances or built-in fixtures (i.e. trim, decorative panels, flooring, cabinetry, islands, countertops, drywall, etc.) that interfere with servicing, removal or replacement of the product.
15. Service or parts for appliances with original model/serial numbers removed, altered or not easily determined.

The cost of repair or replacement under these excluded circumstances shall be borne by the customer.

DISCLAIMER OF IMPLIED WARRANTIES

IMPLIED WARRANTIES, INCLUDING ANY IMPLIED WARRANTY OF MERCHANTABILITY OR IMPLIED WARRANTY OF FITNESS FOR A PARTICULAR PURPOSE, ARE LIMITED TO ONE YEAR OR THE SHORTEST PERIOD ALLOWED BY LAW. Some states and provinces do not allow limitations on the duration of implied warranties of merchantability or fitness, so this limitation may not apply to you. This warranty gives you specific legal rights, and you also may have other rights that vary from state to state or province to province.

DISCLAIMER OF REPRESENTATIONS OUTSIDE OF WARRANTY

Amana makes no representations about the quality, durability, or need for service or repair of this major appliance other than the representations contained in this warranty. If you want a longer or more comprehensive warranty than the limited warranty that comes with this major appliance, you should ask Amana or your retailer about buying an extended warranty.

LIMITATION OF REMEDIES; EXCLUSION OF INCIDENTAL AND CONSEQUENTIAL DAMAGES

YOUR SOLE AND EXCLUSIVE REMEDY UNDER THIS LIMITED WARRANTY SHALL BE PRODUCT REPAIR AS PROVIDED HEREIN. AMANA SHALL NOT BE LIABLE FOR INCIDENTAL OR CONSEQUENTIAL DAMAGES. Some states and provinces do not allow the exclusion or limitation of incidental or consequential damages, so these limitations and exclusions may not apply to you. This warranty gives you specific legal rights, and you also may have other rights that vary from state to state or province to province.

Assistance or Service

Before calling for assistance or service, please check “Troubleshooting” or visit www.amana.com/help. It may save you the cost of a service call. If you still need help, follow the instructions below. When calling, please know the purchase date and the complete model and serial number of your appliance. This information will help us to better respond to your request.

If you need replacement parts or to order accessories

We recommend that you use only FSP® Factory Specified Parts. These parts will fit right and work right because they are made with the same precision used to build every new AMANA® appliance.

To locate FSP® replacement parts or accessories go to www.amanapartsonline.com.

Questions? Call us toll free at **1-866-616-2664** or in Canada call **1-866-587-2002**.

Our consultants provide assistance with

In the U.S.A.

- Features and specifications on our full line of appliances.
- Installation information.
- Specialized customer assistance (Spanish speaking, hearing impaired, limited vision, etc.).

In the U.S.A. and Canada

- Use and maintenance procedures.
- Accessory and repair parts sales.
- Referrals to local dealers, repair parts distributors, and service companies. Whirlpool designated service technicians are trained to fulfill the product warranty and provide after-warranty service, anywhere in the United States and Canada.

You can write with any questions or concerns at:

Amana Brand Appliances
Customer eXperience Center
553 Benson Road
Benton Harbor, MI 49022-2692
1-866-616-2664

Amana Brand Appliances
Customer eXperience Centre
Unit 200-6750 Century Ave
Mississauga, Ontario L5N 0B7
1-866-587-2002

Please include a daytime phone number in your correspondence.

Assistance ou Service

Avant de faire un appel pour obtenir de l'assistance ou un entretien, vérifier la section “Dépannage” ou consulter www.amana.com/help. Cette vérification peut vous faire économiser le coût d'une visite de réparation.

Si vous avez encore besoin d'aide, suivre les instructions ci-dessous.

Lors d'un appel, garder à portée de main la date d'achat et les numéros de modèle et de série de votre appareil. Ces renseignements nous aideront à mieux répondre à votre demande.

Pour commander des pièces de rechange ou des accessoires

Pour commander des pièces de rechange, nous vous recommandons d'utiliser seulement des pièces spécifiées par l'usine. Ces pièces conviendront et fonctionneront bien parce qu'elles sont fabriquées selon les mêmes spécifications précises utilisées pour construire chaque nouvel appareil AMANA®.

Pour trouver des pièces de rechange FSP® ou des accessoires, visiter le www.amanacanada.ca.

Des questions? Composer le numéro sans frais **1-866-587-2002**.

Nos consultants fournissent l'assistance pour :

- Procédés d'utilisation et d'entretien.
- Vente d'accessoires et de pièces de rechange.
- Références aux concessionnaires, compagnies de service de réparation et distributeurs de pièces de rechange locaux. Les techniciens de service désignés par Whirlpool sont formés pour remplir la garantie des produits et fournir un service après la garantie, partout au Canada.

Pour plus d'assistance

Vous pouvez nous soumettre toute question ou tout problème en écrivant à l'adresse ci-dessous :

Amana Brand Appliances
Centre pour l'eXpérience de la clientèle
Unit 200-6750 Century Ave
Mississauga, Ontario L5N 0B7
1-866-587-2002

Dans votre correspondance, veuillez indiquer un numéro de téléphone où nous pouvons vous joindre dans la journée.