

INSTALLATION INSTRUCTIONS 30" (76.2 CM) DOUBLE OVEN GAS RANGES

INSTRUCTIONS POUR L'INSTALLATION DES CUISINIÈRES À GAZ À DOUBLE FOUR DE 30" (76,2 CM)

Table of Contents/Table des matières

| | | | |
|--|----|--|----|
| RANGE SAFETY | 2 | SÉCURITÉ DE LA CUISINIÈRE | 19 |
| INSTALLATION REQUIREMENTS | 3 | EXIGENCES D'INSTALLATION | 20 |
| Tools and Parts..... | 3 | Outils et pièces..... | 20 |
| Location Requirements | 3 | Exigences d'emplacement..... | 21 |
| Electrical Requirements | 5 | Spécifications électriques | 22 |
| Gas Supply Requirements | 6 | Spécifications de l'alimentation en gaz | 23 |
| INSTALLATION INSTRUCTIONS | 7 | INSTRUCTIONS D'INSTALLATION | 24 |
| Unpack Range..... | 7 | Déballage de la cuisinière | 24 |
| Adjust Leveling Legs | 7 | Réglage des pieds de nivellement..... | 24 |
| Install Anti-Tip Bracket..... | 7 | Installation de la bride antibasculement | 25 |
| Make Gas Connection | 8 | Raccordement au gaz..... | 25 |
| Verify Anti-Tip Bracket Is Installed and Engaged | 9 | Vérifier que la bride antibasculement est bien installée et engagée | 26 |
| Level Range..... | 10 | Réglage de l'aplomb de la cuisinière..... | 27 |
| Electronic Ignition System | 10 | Système d'allumage électronique..... | 27 |
| Complete Installation | 11 | Achever l'installation | 28 |
| GAS CONVERSIONS | 12 | CONVERSIONS POUR CHANGEMENT DE GAZ | 29 |
| LP Gas Conversion | 12 | Conversion pour l'alimentation au propane | 29 |
| Natural Gas Conversion | 15 | Conversion pour l'alimentation au gaz naturel | 33 |

IMPORTANT:

Save for local electrical inspector's use.

Installer: Leave installation instructions with the homeowner.

Homeowner: Keep installation instructions for future reference.

IMPORTANT :

À conserver pour consultation par l'inspecteur local des installations électriques.

Installateur : Remettre les instructions d'installation au propriétaire.

Propriétaire : Conserver les instructions d'installation pour référence ultérieure.

RANGE SAFETY

Your safety and the safety of others are very important.

We have provided many important safety messages in this manual and on your appliance. Always read and obey all safety messages.



This is the safety alert symbol.

This symbol alerts you to potential hazards that can kill or hurt you and others.

All safety messages will follow the safety alert symbol and either the word "DANGER" or "WARNING."

These words mean:

⚠ DANGER

You can be killed or seriously injured if you don't immediately follow instructions.

⚠ WARNING

You can be killed or seriously injured if you don't follow instructions.

All safety messages will tell you what the potential hazard is, tell you how to reduce the chance of injury, and tell you what can happen if the instructions are not followed.

WARNING: If the information in this manual is not followed exactly, a fire or explosion may result causing property damage, personal injury or death.

- Do not store or use gasoline or other flammable vapors and liquids in the vicinity of this or any other appliance.
- **WHAT TO DO IF YOU SMELL GAS:**
 - Do not try to light any appliance.
 - Do not touch any electrical switch.
 - Do not use any phone in your building.
 - Immediately call your gas supplier from a neighbor's phone. Follow the gas supplier's instructions.
 - If you cannot reach your gas supplier, call the fire department.
- Installation and service must be performed by a qualified installer, service agency or the gas supplier.

WARNING: Gas leaks cannot always be detected by smell.

Gas suppliers recommend that you use a gas detector approved by UL or CSA.

For more information, contact your gas supplier.

If a gas leak is detected, follow the "What to do if you smell gas" instructions.

IMPORTANT: Do not install a ventilation system that blows air downward toward this gas cooking appliance. This type of ventilation system may cause ignition and combustion problems with this gas cooking appliance resulting in personal injury or unintended operation.

In the State of Massachusetts, the following installation instructions apply:

- Installations and repairs must be performed by a qualified or licensed contractor, plumber, or gasfitter qualified or licensed by the State of Massachusetts.
- If using a ball valve, it shall be a T-handle type.
- A flexible gas connector, when used, must not exceed 3 feet.

⚠ WARNING

Tip Over Hazard

A child or adult can tip the range and be killed.

Install anti-tip bracket to floor or wall per installation instructions.

Slide range back so rear range foot is engaged in the slot of the anti-tip bracket.

Re-engage anti-tip bracket if range is moved.

Do not operate range without anti-tip bracket installed and engaged.

Failure to follow these instructions can result in death or serious burns to children and adults.

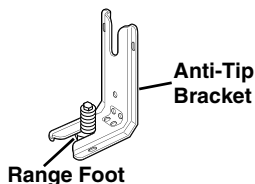
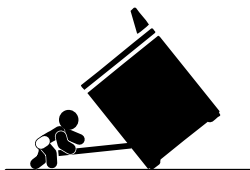

To verify the anti-tip bracket is installed and engaged:

- Slide range forward.
- Look for the anti-tip bracket securely attached to floor or wall.
- Slide range back so rear range foot is under anti-tip bracket.
- See installation instructions for details.

INSTALLATION REQUIREMENTS

Tools and Parts

Gather the required tools and parts before starting installation. Read and follow the instructions provided with any tools listed here.

Tools Needed

- Tape measure
- Phillips screwdriver
- TORX®† T20®† screwdriver
- Flat-blade screwdriver
- 1/8" flat-blade screwdriver
- Level
- Hand or electric drill
- Wrench or pliers
- Pipe wrench
- 15/16" combination wrench
- 1/8" (3.2 mm) drill bit
- Marker or pencil
- Pipe-joint compound resistant to LP gas
- Noncorrosive leak-detection solution
- For LP/Natural Gas Conversions**
- 1/2" combination wrench
- 9/32" (7.0 mm) nut driver
- Masking tape

Parts supplied

Check that all parts are included.

- LP/Natural Gas Conversion Kit (located on back of range near lower side)
- Burner grates
- Burner caps
- Oven racks
- 2 - #12 x 1 5/8" screws (for mounting anti-tip bracket)

- Anti-tip bracket (taped inside upper oven with literature package)

Anti-tip bracket must be securely mounted to the back wall or floor. Thickness of flooring may require longer screws to anchor bracket to subfloor. Longer screws are available from your local hardware store.

Parts needed

Check local codes and consult gas supplier. Check existing gas supply and electrical supply. See the "Electrical Requirements" and "Gas Supply Requirements" sections.

Location Requirements

IMPORTANT: Observe all governing codes and ordinances. Do not obstruct flow of combustion and ventilation air.

- It is the installer's responsibility to comply with installation clearances specified on the model/serial/rating number plate. The model/serial/rating number plate is located behind the control panel.
- The range should be located for convenient use in the kitchen.
- Recessed installations must provide complete enclosure of the sides and rear of the range.
- All openings in the wall or floor where range is to be installed must be sealed.

†®TORX and T20 are registered trademarks of Acument Intellectual Properties, LLC.

- Cabinet opening dimensions that are shown must be used. Given dimensions are minimum clearances.
- The floor anti-tip bracket must be installed. To install the antitip bracket shipped with the range, see the “Install Anti-Tip Bracket” section.
- Grounded electrical supply is required. See the “Electrical Requirements” section.
- Proper gas supply connection must be available. See the “Gas Supply Requirements” section.
- Contact a qualified floor covering installer to check that the floor covering can withstand at least 200°F (93°C).
- Use an insulated pad or 1/4" (0.64 cm) plywood under range if installing range over carpeting.

IMPORTANT: To avoid damage to your cabinets, check with your builder or cabinet supplier to make sure that the materials used will not discolor, delaminate, or sustain other damage. This range has been designed in accordance with the requirements of UL and CSA International and complies with the maximum allowable wood cabinet temperatures of 194°F (90°C).

Mobile Home - Additional Installation Requirements

The installation of this range must conform to the Manufactured Home Construction and Safety Standard, Title 24 CFR, Part 3280 (formerly the Federal Standard for Mobile Home Construction and Safety, Title 24, HUD Part 280). When such standard is not applicable, use the Standard for Manufactured Home Installations, ANSI A225.1/NFPA 501A, or local codes.

In Canada, the installation of this range must conform with the current standards CAN/CSA-A240 - latest edition or with local codes.

Mobile home installations require:

- When this range is installed in a mobile home, it must be secured to the floor during transit. Any method of securing the range is adequate as long as it conforms to the standards listed above.

Product Dimensions

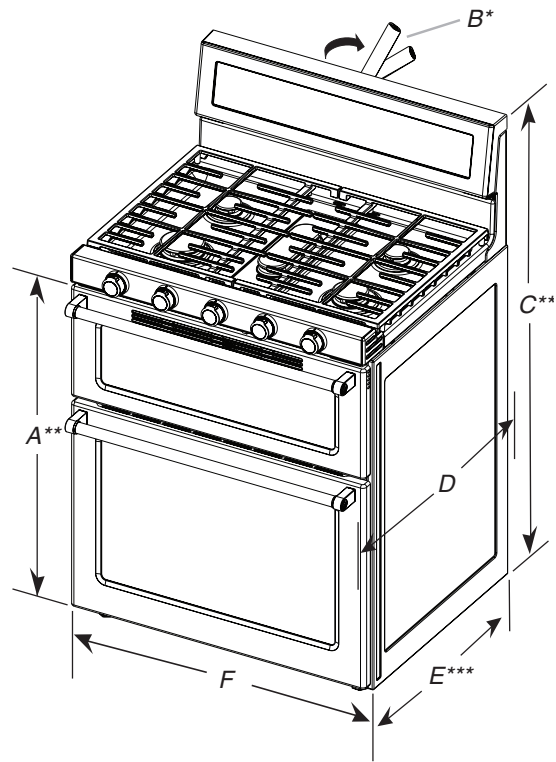

- | | |
|---|---|
| <p>A. $35\frac{3}{4}'' \pm \frac{1}{8}''$ (90.8 cm \pm 0.3 cm) cooktop height (minimum) with leveling legs screwed all the way in</p> <p>B. Model/serial/rating plate (located behind the control panel)*</p> | <p>C. $47\frac{1}{8}'' \pm \frac{1}{8}''$ (119.7 cm \pm 0.3 cm) overall height (minimum) with leveling legs screwed all the way in**</p> <p>D. $28\frac{1}{2}'' \pm \frac{1}{4}''$ (72.4 cm \pm 0.6 cm) depth with handle</p> <p>E. $26\frac{1}{8}''$ to $27\frac{1}{4}'' \pm \frac{1}{8}''$ (66.4 to 69.2 cm \pm 0.3 cm)***</p> <p>F. $29\frac{15}{16}'' \pm \frac{1}{16}''$ (76.0 cm \pm 0.2 cm) width</p> |
|---|---|

* Model/serial/rating plate may be rotated up from behind the control panel for viewing from the front of the range.

** Range can be raised approximately 1" (2.5 cm) by adjusting the leveling legs.

*** Excludes handle. Dimension given is from wall to front of oven door and will vary based on electric outlet receptacle installation.

Cabinet Dimensions

Cabinet opening dimensions shown are for 25" (63.5 cm) countertop depth, 24" (61.0 cm) base cabinet depth, and 36" (91.4 cm) countertop height.

IMPORTANT: If installing a range hood or microwave hood combination above the range, follow the range hood or microwave hood combination installation instructions for dimensional clearances above the cooktop surface.

Range may be installed with zero clearance to combustible construction at the rear and on the sides below the cooktop.

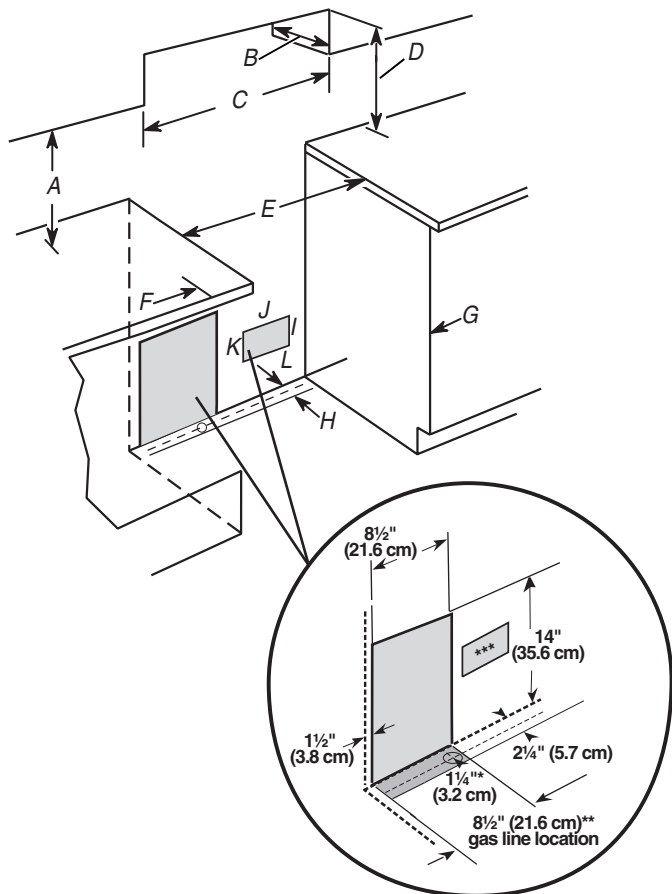

- A. 18" (45.7 cm) upper cabinet to countertop
- B. 13" (33.0 cm) upper cabinet depth
- C. 30" (76.2 cm) min. opening width
- D. For minimum clearance to the top of the cooktop, see NOTE.
- E. 30" (76.2 cm) min. opening width
- F. 3" (7.6 cm) min. clearance from both sides of the range to the side wall or other combustible material
- G. Cabinet door or hinges should not extend into the cutout.
- H. 3" (7.6 cm) distance from wall
- I. 1 1/2" (3.8 cm) min. from right side cabinet
- J. 8" (20.3 cm) width
- K. 7" (17.8 cm) height
- L. 2" (5.1 cm) min. from floor

* Drill on centerline 1 1/4" (3.1 cm) from rear wall for gas supply line.

** Gas lines must be installed within the shaded area to ensure proper alignment of this oven with cabinets.

*** Electrical plugs must be installed within the shaded area to ensure proper alignment of this oven with cabinets.

NOTE: 24" (61.0 cm) minimum when bottom of wood or metal cabinet is covered by not less than 1/4" (0.64 cm) flame-retardant millboard covered with not less than No. 28 MSG sheet steel, 0.015" (0.4 mm) stainless steel, 0.024" (0.6 mm) aluminum, or 0.020" (0.5 mm) copper.

30" (76.2 cm) minimum clearance between the top of the cooking platform and the bottom of an uncovered wood or metal cabinet.

Electrical Requirements

⚠ WARNING



Electrical Shock Hazard

Plug into a grounded 3 prong outlet.

Do not remove ground prong.

Do not use an adapter.

Do not use an extension cord.

Failure to follow these instructions can result in death, fire, or electrical shock.

IMPORTANT: The range must be electrically grounded in accordance with local codes and ordinances, or in the absence of local codes, with the National Electrical Code, ANSI/NFPA 70 or Canadian Electrical Code, CSA C22.1.

If codes permit and a separate ground wire is used, it is recommended that a qualified electrical installer determine that the ground path is adequate.

A copy of the above code standards can be obtained from:

National Fire Protection Association
1 Batterymarch Park
Quincy, MA 02169-7471
CSA International
8501 East Pleasant Valley Road
Cleveland, OH 44131-5575

- A 120-volt, 60 Hz., AC-only, 15-amp fused, electrical circuit is required. A time-delay fuse or circuit breaker is also recommended. It is recommended that a separate circuit serving only this range be provided.
- Electronic ignition systems operate within wide voltage limits, but proper grounding and polarity are necessary. Check that the outlet provides 120-volt power and is correctly grounded.
- The wiring diagram is located on the back of the range in a clear plastic bag.

Gas Supply Requirements

⚠ WARNING



Explosion Hazard

Use a new CSA International approved gas supply line.

Install a shut-off valve.

Securely tighten all gas connections.

If connected to LP, have a qualified person make sure gas pressure does not exceed 14" (36 cm) water column.

Examples of a qualified person include:

licensed heating personnel,
authorized gas company personnel, and
authorized service personnel.

Failure to do so can result in death, explosion, or fire.

Observe all governing codes and ordinances.

IMPORTANT: This installation must conform with all local codes and ordinances. In the absence of local codes, installation must conform with American National Standard, National Fuel Gas Code ANSI Z223.1 - latest edition or CAN/CGA B149 - latest edition.

IMPORTANT: Leak testing of the range must be conducted according to the manufacturers instructions.

Type of Gas

Natural gas:

This range is factory set for use with Natural gas. See the "Gas Conversions" section. The model/serial/rating plate located behind the control panel has information on the types of gas that can be used. If the types of gas listed do not include the type of gas available, check with the local gas supplier.

LP gas conversion:

Conversion must be done by a qualified service technician.

No attempt shall be made to convert the appliance from the gas specified on the model/serial/rating plate for use with a different gas without consulting the serving gas supplier. See the "Gas Conversions" section.

Gas Supply Line

- Provide a gas supply line of $\frac{3}{4}$ " (1.9 cm) rigid pipe to the range location. A smaller size pipe on longer runs may result in insufficient gas supply. With LP gas, piping or tubing size can be $\frac{1}{2}$ " (1.3 cm) minimum. Usually, LP gas suppliers determine the size and materials used in the system.

NOTE: Pipe-joint compounds that resist the action of LP gas must be used. Do not use TEFLON^{®†} tape.

Flexible metal appliance connector:

- If local codes permit, a new CSA design-certified, 4 to 5 ft (122 to 152.4 cm) long, $\frac{1}{2}$ " (1.3 cm) or $\frac{3}{4}$ " (1.9 cm) I.D. (inside diameter), flexible metal appliance connector may be used for connecting range to the gas supply line.



- A $\frac{1}{2}$ " (1.3 cm) male pipe thread is needed for connection to the female pipe threads of the inlet to the appliance pressure regulator.

- Do not kink or damage the flexible metal tubing when moving the range.

- Must include a shut-off valve:

The supply line must be equipped with a manual shut-off valve. This valve should be located in the same room but external to the range opening, such as an adjacent cabinet. It should be in a location that allows ease of opening and closing. Do not block access to shut-off valve. The valve is for turning on or shutting off gas to the range.

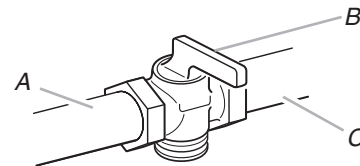

- A. Gas supply line
- B. Shut-off valve open position
- C. To range

Gas Pressure Regulator

The gas pressure regulator supplied with this range must be used. The inlet pressure to the regulator should be as follows for proper operation:

Natural gas:

Minimum pressure: 5" WCP

Maximum pressure: 14" WCP

LP gas:

Minimum pressure: 11" WCP

Maximum pressure: 14" WCP

Contact local gas supplier if you are not sure about the inlet pressure.

[†]TEFLON is a registered trademark of Chemours.

Burner Input Requirements

Input ratings shown on the model/serial/rating plate are for elevations up to 2,000 ft (609.6 m).

For elevations above 2,000 ft (609.6 m), ratings are reduced at a rate of 4% for each 1,000 ft (304.8 m) above sea level (not applicable for Canada).

Gas Supply Pressure Testing

Gas supply pressure for testing regulator must be at least 1" water column pressure above the manifold pressure shown on the model/serial/rating plate.

Line pressure testing above 1/2 psi gauge (14" WCP)

The range and its individual shut-off valve must be disconnected from the gas supply piping system during any pressure testing of that system at test pressures in excess of 1/2 psi (3.5 kPa).

Line pressure testing at 1/2 psi gauge (14" WCP) or lower

The range must be isolated from the gas supply piping system by closing its individual manual shut-off valve during any pressure testing of the gas supply piping system at test pressures equal to or less than 1/2 psi (3.5 kPa).

INSTALLATION INSTRUCTIONS

Unpack Range

! WARNING

Excessive Weight Hazard

Use two or more people to move and install range.
Failure to do so can result in back or other injury.

1. Remove shipping materials, tape, and film from the range. Keep cardboard bottom under range.
2. Remove oven racks and parts package from inside oven.
3. To place range on its back, take 4 cardboard corners from the carton. Stack one cardboard corner on top of another. Repeat with the other 2 corners. Place them lengthwise on the floor behind the range to support the range when it is laid on its back.
4. Using 2 or more people, firmly grasp the range and gently lay it on its back on the cardboard corners.
5. Pull cardboard bottom firmly to remove.
6. Use an adjustable wrench to loosen the leveling legs.
7. Place cardboard or hardboard in front of range. Using 2 or more people, stand range back up onto cardboard or hardboard.

Adjust Leveling Legs

1. If range height adjustment is necessary, use a wrench or pliers to loosen the 4 leveling legs.
This may be done with the range on its back or with the range supported on 2 legs after the range has been placed back to a standing position.
NOTE: To place range back up into a standing position, put a sheet of cardboard or hardboard in front of range. Using 2 or more people, stand range back up onto the cardboard or hardboard.
2. Adjust the leveling legs to the correct height. Leveling legs can be loosened to add up to a maximum of 1" (2.5 cm). A minimum of 3/16" (5.0 mm) is needed to engage the anti-tip bracket.
NOTE: If height adjustment is made when range is standing, tilt the range back to adjust the front legs, then tilt forward to adjust the rear legs.
3. When the range is at the correct height, check that there is adequate clearance under the range for the anti-tip bracket. Before sliding range into its final location, check that the anti-tip bracket will slide under the range and onto the rear leveling leg prior to anti-tip bracket installation.

Install Anti-Tip Bracket

! WARNING

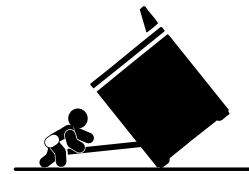

Tip Over Hazard

A child or adult can tip the range and be killed.

Install anti-tip bracket to floor or wall per installation instructions.

Slide range back so rear range foot is engaged in the slot of the anti-tip bracket.

Re-engage anti-tip bracket if range is moved.

Do not operate range without anti-tip bracket installed and engaged.

Failure to follow these instructions can result in death or serious burns to children and adults.

1. Remove the anti-tip bracket that is taped inside the upper oven with the package containing literature.
2. Determine which mounting method to use: floor or wall.
If you have a stone or masonry floor, you can use the wall mounting method.

- Determine and mark edge of range in the cutout space. The mounting bracket can be installed on either the left side or right side of the cutout. Position mounting bracket in cutout so that right (or left) edge of the bracket is $\frac{15}{16}$ " (2.4 cm) from the marked edge of the range, as shown.

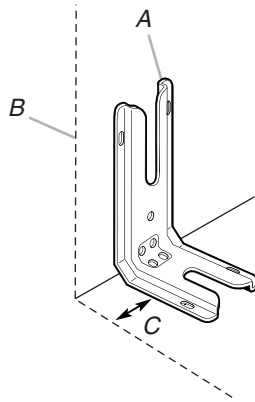

- A. Anti-tip bracket
- B. Mark edge of range.
- C. $\frac{15}{16}$ " (2.4 cm)

- Drill two $\frac{1}{8}$ " (3.0 mm) holes that correspond to the bracket holes of the determined mounting method. See the following illustrations.

Floor Mounting

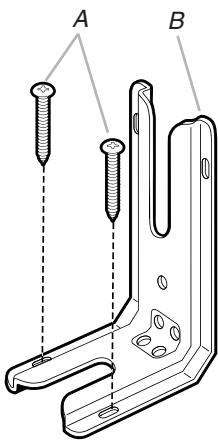

- A. #12 x $\frac{15}{8}$ " screws
- B. Anti-tip bracket

Wall Mounting

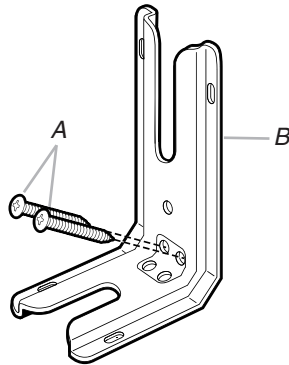

- A. #12 x $\frac{15}{8}$ " screws
- B. Anti-tip bracket

- Using a Phillips screwdriver, mount anti-tip bracket to the wall or floor with the two #12 x $\frac{15}{8}$ " screws provided.

Make Gas Connection

⚠ WARNING



Explosion Hazard

Use a new CSA International approved gas supply line.

Install a shut-off valve.

Securely tighten all gas connections.

If connected to LP, have a qualified person make sure gas pressure does not exceed 14" (36 cm) water column.

Examples of a qualified person include:

licensed heating personnel,
authorized gas company personnel, and
authorized service personnel.

Failure to do so can result in death, explosion, or fire.

Typical flexible connection

- Apply pipe-joint compound made for use with LP gas to the smaller thread ends of the flexible connector adapters (see B and G in the following illustration).
- Attach one adapter to the gas pressure regulator and the other adapter to the gas shut-off valve. Tighten both adapters being certain not to move or turn the gas pressure regulator.
- Use a $\frac{15}{16}$ " combination wrench and an adjustable wrench to attach the flexible connector to the adapters.

IMPORTANT: All connections must be wrench-tightened. Do not make connections to the gas pressure regulator too tight. Making the connections too tight may crack the regulator and cause a gas leak. Do not allow the regulator to turn when tightening the fittings.

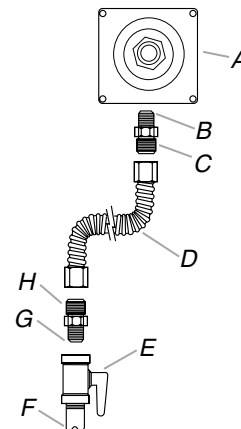

- A. Gas pressure regulator
- B. Use pipe-joint compound.
- C. Adapter (must have $\frac{1}{2}$ " male pipe thread)
- D. Flexible connector
- E. Manual gas shut-off valve
- F. $\frac{1}{2}$ " or $\frac{3}{4}$ " gas pipe
- G. Use pipe-joint compound.
- H. Adapter

- Gas supply pipe must be located within the shaded area as shown in the "Cabinet Dimensions" illustration in the "Location Requirements" section.

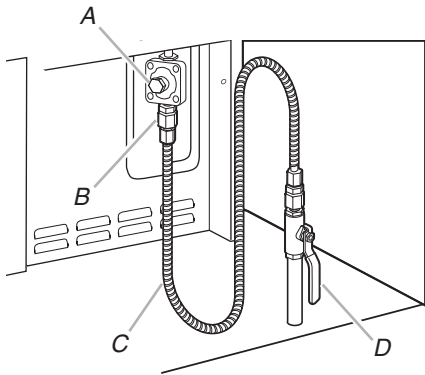

A. Gas pressure regulator
B. Adapter
C. Flexible connector
D. Manual shut-off valve

Complete connection

- Open the manual shut-off valve in the gas supply line. The valve is open when the handle is parallel to the gas pipe.

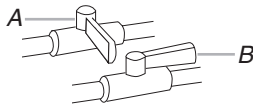

A. Closed valve
B. Open valve

- Test all connections by brushing on an approved noncorrosive leak-detection solution. If bubbles appear, a leak is indicated. Correct any leak found.
- Remove cooktop burner caps and grates from parts package. Align recess in burner caps with pins in burner base. Burner caps should be level when properly positioned. If burner caps are not properly positioned, surface burners will not light. Place burner grates over burners and caps.

⚠ WARNING



Electrical Shock Hazard

Plug into a grounded 3 prong outlet.

Do not remove ground prong.

Do not use an adapter.

Do not use an extension cord.

Failure to follow these instructions can result in death, fire, or electrical shock.

- Plug into a grounded 3 prong outlet.

Verify Anti-Tip Bracket Is Installed and Engaged

- Place the outside of your foot against the bottom front of the oven door to keep the range from moving, and grasp the lower right or left side of the control panel as shown.

NOTE: If your countertop is mounted with a backsplash, it may be necessary to grasp the range higher than is shown in the illustration.

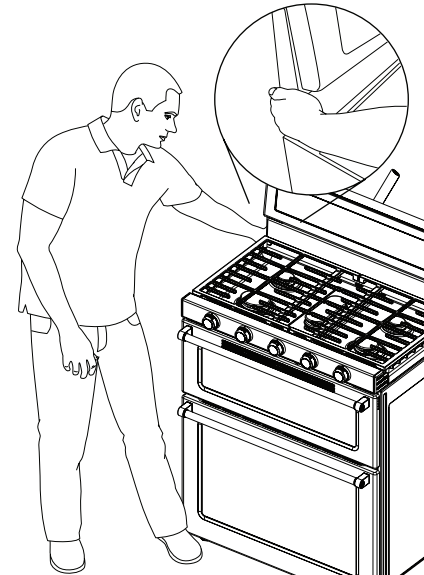

- Slowly attempt to tilt the range forward. If you encounter immediate resistance, the range foot is engaged in the anti-tip bracket.
- If the rear of the range lifts more than $\frac{1}{2}$ " (1.3 cm) off the floor without resistance, stop tilting the range and lower it gently back to the floor. The range foot is not engaged in the anti-tip bracket.

IMPORTANT: If there is a snapping or popping sound when lifting the range, the range may not be fully engaged in the bracket. Check to see if there are obstructions keeping the range from sliding to the wall or keeping the range foot from sliding into the bracket. Verify that the bracket is held securely in place by the mounting screws.

- Slide the range forward and verify that the anti-tip bracket is securely attached to the floor or wall.
- Slide range back so the rear range foot is inserted into the slot of the anti-tip bracket.

IMPORTANT: If the back of the range is more than 2" (5.1 cm) from the mounting wall, the rear range foot may not engage the bracket. Slide the range forward and determine if there is an obstruction between the range and the mounting wall. If you need assistance or service, refer to the "Assistance or Service" section of the Use and Care Guide, or the cover or the "Warranty" section of the User Instructions, for contact information.

- Repeat steps 1 and 2 to ensure that the range foot is engaged in the anti-tip bracket.

If the rear of the range lifts more than $\frac{1}{2}$ " (1.3 cm) off the floor without resistance, the anti-tip bracket may not be installed correctly. Do not operate the range without anti-tip bracket installed and engaged. Please reference the "Assistance or Service" section of the Use and Care Guide, or the cover or the "Warranty" section of the User Instructions, to contact service.

Level Range

1. Place a rack in oven.
2. Place level on rack and check levelness of range, first side to side, then front to back.

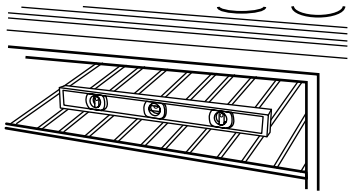

3. If range is not level, pull range forward until rear leveling leg is removed from the anti-tip bracket.
4. Use a wrench or pliers to adjust leveling legs up or down until the range is level. Push range back into position.
5. Check that rear leveling leg is engaged in the anti-tip bracket.

NOTE: Range must be level for satisfactory baking performance.

Electronic Ignition System

Initial lighting and gas flame adjustments

Cooktop and oven burners use pilotless igniters in place of standing pilots. When the cooktop control knob is turned to the Lite position, the system creates a spark to light the burner. This sparking continues, as long as the control knob is turned to Lite.

When the oven control is turned to the desired setting, a glow bar igniter heats and ignites the gas.

Check Operation of Cooktop Burners

Standard Surface Burners

Push in and turn each control knob to the Lite position. The flame should light within 4 seconds. The first time a burner is lit it may take longer than 4 seconds to light because of air in the gas line.

If burners do not light properly:

- Turn cooktop control knob to the Off position.
- Check that the range is plugged in and the circuit breaker as not tripped or the household fuse has not blown.
- Check that the gas shut-off valve is set to the "open" position.
- Check that burner caps are properly positioned on burner bases.

Repeat start-up. If a burner does not light at this point, turn the control knobs to OFF and contact your dealer or authorized service company for assistance.

Adjust Flame Height

Adjust the height of top burner flames. The cooktop LO burner flame should be a steady blue flame approximately $\frac{1}{4}$ " (0.64 cm) high.

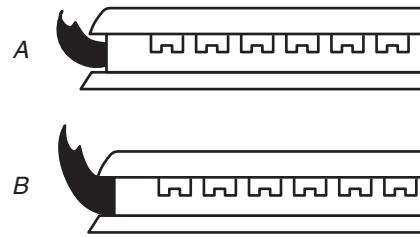

A. Low flame
B. High flame

To adjust standard burners:

The flame can be adjusted using the adjustment screw in the center of the valve stem. The valve stem is located directly underneath the control knob.

If the low flame needs to be adjusted:

1. Light 1 burner and turn to lowest setting.
2. Remove the control knob.

Hold the knob stem in the low position using a pair of pliers. Use a $\frac{1}{8}$ " (3.0 mm) flat-blade screwdriver to turn the screw located in the center of the control knob stem until the flame is the proper size.

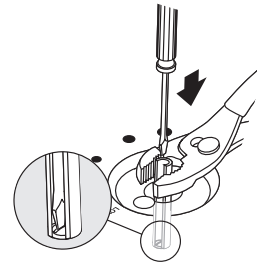

3. Replace the control knob.
4. Test the flame by turning the control from LO to HI, checking the flame at each setting.
5. Repeat steps 1 - 4 for each burner.

Check Operation of Both Oven Bake Burners

1. Press the Bake keypad for the desired oven.
"BAKE" scrolls down in the upper text display area or scrolls up in the lower text display area, depending on oven selection, and 350°F is displayed. After 3 seconds "Set temp" scrolls in the selected oven text display area, followed by "Push START."
2. Press Start keypad. "Baking" scrolls in the selected oven text display area. Then, after 3 seconds, "Preheating" scrolls in the display.

The igniter used to light the bake burner will glow. Once the igniter is hot, the oven bake burner should light. Under certain conditions, it may take up to 60 seconds for it to light.

If burners do not light properly:

- Press OFF/CANCEL to turn off the oven.
- Check that the range is plugged in and circuit breaker has not tripped or the household fuse has not blown.
- Check that the gas shut-off valve is set to the open position.

Repeat start-up. If burner does not light, press OFF/CANCEL to turn off the oven and contact your dealer or authorized service company for assistance.

Check Operation of Oven Broil Burner

1. Press BROIL for the upper oven. "BROIL" scrolls down in the upper text display area, and 550°F is displayed. After 3 seconds, "Set temp" scrolls in the upper oven text display area, followed by "Push START."
2. Press START. "Broiling" scrolls in the upper oven text display area and remains there until the set temperature is reached.
The igniter used to light the broil burner will glow. Once the igniter is hot, the oven burner should light. Under certain conditions, it may take up to 60 seconds for it to light.

If burners do not light properly:

- Press OFF/CANCEL to turn off the oven.
- Check that the range is plugged in and circuit breaker has not tripped or the household fuse has not blown.
- Check that the gas shut-off valve is set to the open position.

Repeat start-up. If burner does not light, press OFF/CANCEL to turn off the oven and contact your dealer or authorized service company for assistance.

Complete Installation

1. Check that all parts are now installed. If there is an extra part, go back through the steps to see which step was skipped.
2. Check that you have all of your tools.
3. Dispose of/recycle all packaging materials.
4. Check that the range is level. See the "Level Range" section.
5. Use a mild solution of liquid household cleaner and warm water to remove waxy residue caused by shipping material. Dry thoroughly with a soft cloth. For more information, read the "Range Care" section of the Use and Care Guide.
6. Read the range Use and Care Guide or User Instructions.
7. Turn power on. Turn on surface elements and oven. See the Use and Care Guide for specific instruction on range operation.

If range does not operate, check the following:

- Household fuse is intact and tight; or circuit breaker has not tripped.
 - Range is plugged into a grounded outlet.
 - Electrical supply is connected.
 - See the "Troubleshooting" section in the Use and Care Guide.
8. When the range has been on for 5 minutes, check for heat. If the range is cold, turn off the range and check that the gas supply line shut-off valve is open.
 - If the gas supply line shut-off valve is closed, open it, then repeat the 5-minute test as outlined above.
 - If the gas supply line shut-off valve is open, press the Cancel button on the oven control panel and contact a qualified technician.

If you need Assistance or Service:

Please reference the "Warranty" section of the Use and Care Guide or User Instructions.

GAS CONVERSIONS

Gas conversions from Natural gas to LP gas or from LP gas to Natural gas must be done by a qualified installer.

⚠ WARNING



Explosion Hazard

Use a new CSA International approved gas supply line.

Install a shut-off valve.

Securely tighten all gas connections.

If connected to LP, have a qualified person make sure gas pressure does not exceed 14" (36 cm) water column.

Examples of a qualified person include:

licensed heating personnel,
authorized gas company personnel, and
authorized service personnel.

Failure to do so can result in death, explosion, or fire.

LP Gas Conversion

⚠ WARNING

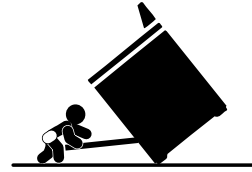

Tip Over Hazard

A child or adult can tip the range and be killed.

Install anti-tip bracket to floor or wall per installation instructions.

Slide range back so rear range foot is engaged in the slot of the anti-tip bracket.

Re-engage anti-tip bracket if range is moved.

Do not operate range without anti-tip bracket installed and engaged.

Failure to follow these instructions can result in death or serious burns to children and adults.

1. Turn manual shut-off valve to the closed position.

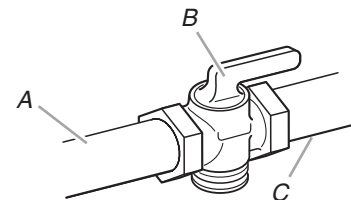

- A. To range
- B. Shut-off valve (closed position)
- C. Gas supply line

2. Unplug range or disconnect power.

To Convert Gas Pressure Regulator

1. Locate gas pressure regulator at the rear of the range.

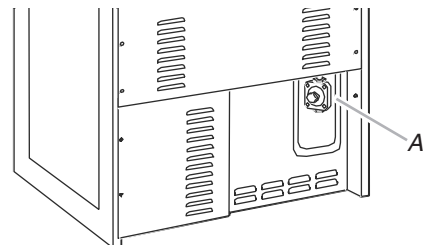

A. Gas pressure regulator

IMPORTANT: Do not remove the gas pressure regulator.

2. Unscrew the regulator cap and remove the plastic cover.

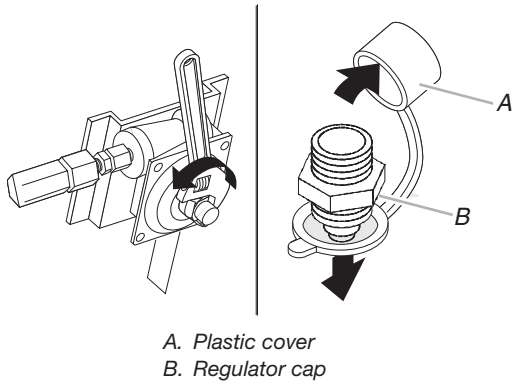

3. Flip the regulator cap over and replace the plastic cover.

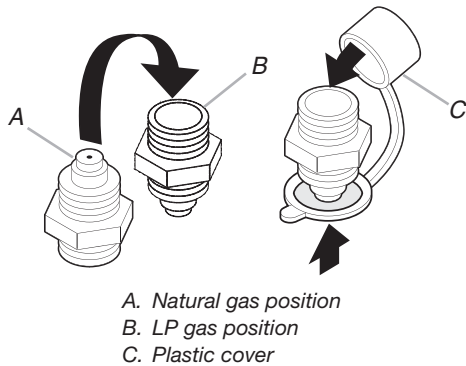

4. Screw the regulator cap securely back into place. Do not overtighten.

To Convert Oven Bake Burners (Nat. gas to LP)

To Convert Lower Oven Bake Burner:

1. Remove oven racks from inside the oven cavity.
2. Remove oven door. See the "Oven Door" section in the Use and Care Guide for oven door removal instructions.
3. Push the bake burner cover to the right.

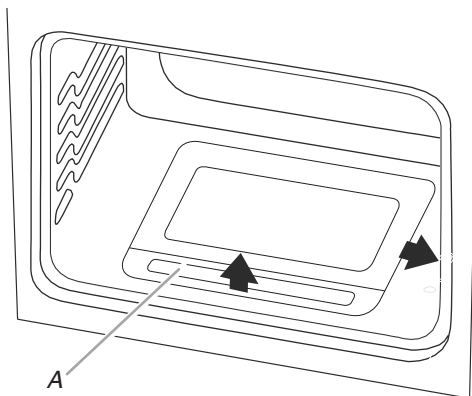

4. Lift up and remove oven bake burner cover.

5. Unscrew wing nut and remove oven baffle.

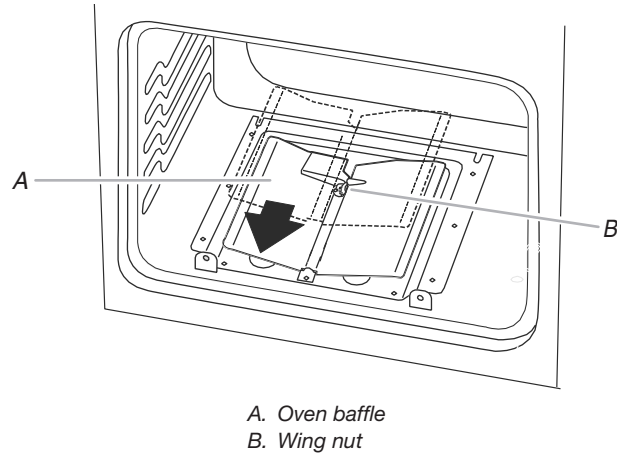

6. Remove the oven bake burner screw and set aside.
7. Gently set the bake burner to the side.

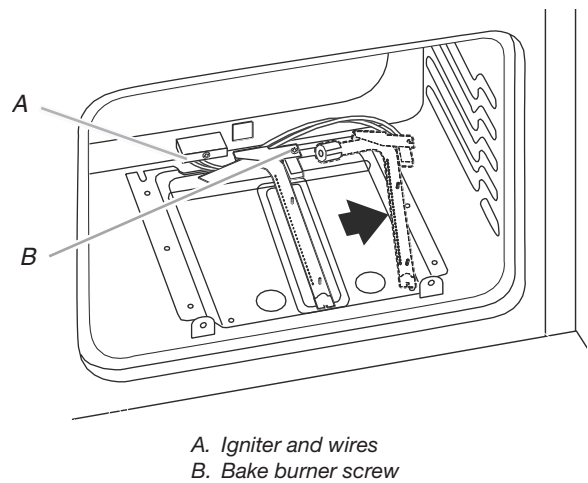

8. Unscrew and remove the cover over the orifice.

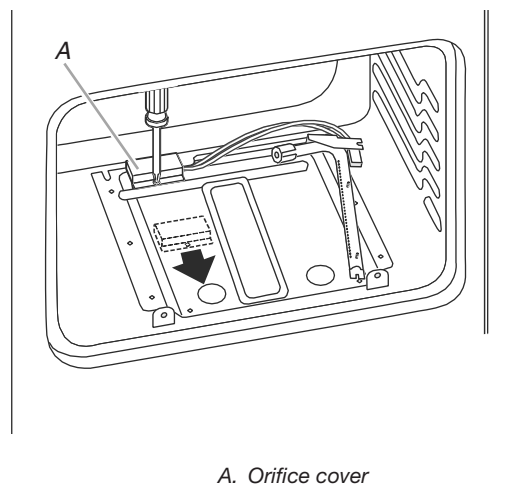

- Turn the Number 0.070 Natural gas orifice hood counterclockwise to remove.

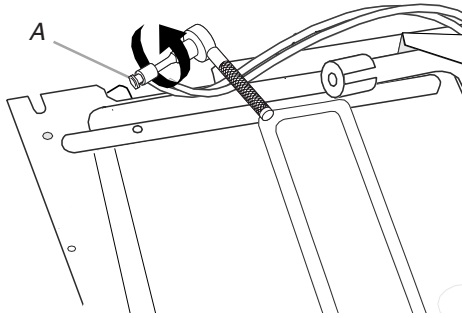

A. Number 0.070 Natural gas orifice hood

- Install the Number 0.044 LP gas orifice hood, turning it clockwise 4 or 5 turns. Do not overtighten.

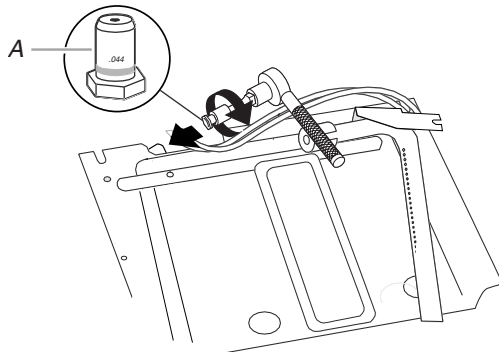

A. Number 0.044 LP gas orifice hood

- Position the oven bake burner over the orifice hood and reinstall using screw.

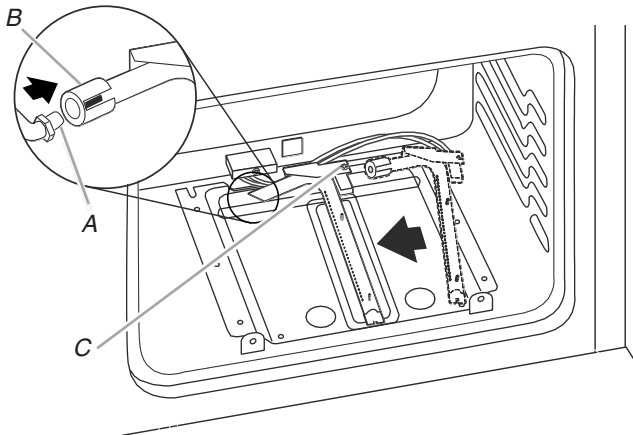

A. Bake burner orifice hood
B. Oven bake burner
C. Oven bake burner screw

Convert Upper Oven Bake Burner

- Repeat steps 1 through 8 above for conversion of the upper oven bake burner.
- Remove the Number 0.055 Natural gas orifice spud in the upper oven and replace with a Number 0.037 LP gas orifice spud.
- Reverse steps to reinstall the orifice covers, oven bake burners, oven baffles, and oven bake covers in both ovens.

To Convert Oven Broil Burner

- Remove broil burner screw and set aside.
- Remove the broil burner from the broil burner orifice hood. The broil burner will hang in the back of the oven while changing the orifice hood.

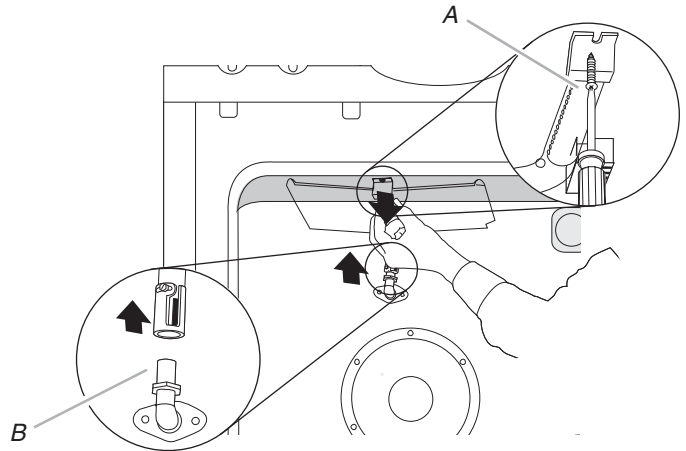

A. Broil burner screw
B. Broil burner orifice hood

- Turn the Number 0.054 Natural gas broil burner orifice hood counterclockwise to remove.

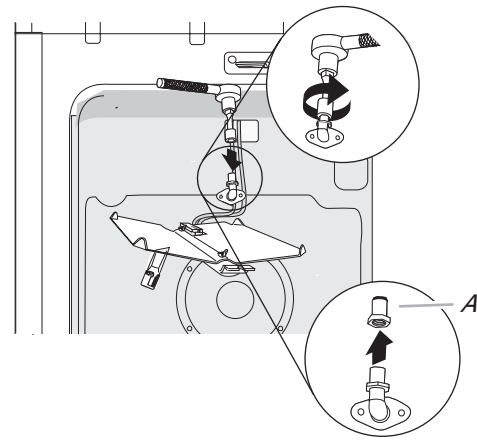

A. Number 0.054 Natural gas broil burner orifice hood

- Install the green Number 0.037 LP gas broil burner orifice hood, turning it clockwise 4 or 5 turns. Do not overtighten.

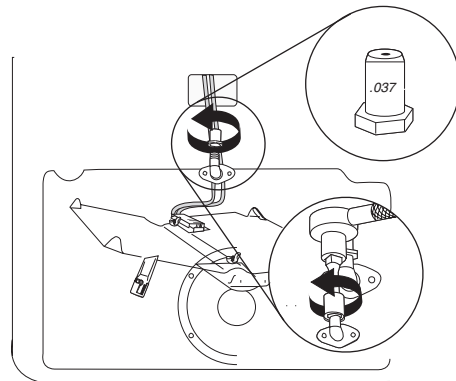

A. Number 0.037 LP gas broil burner orifice hood

- Place the broil burner on the broil burner orifice hood. Insert the broil burner locator pin in the hole in the oven back.

- Position the broil burner against the roof of the oven cavity and attach with screw.

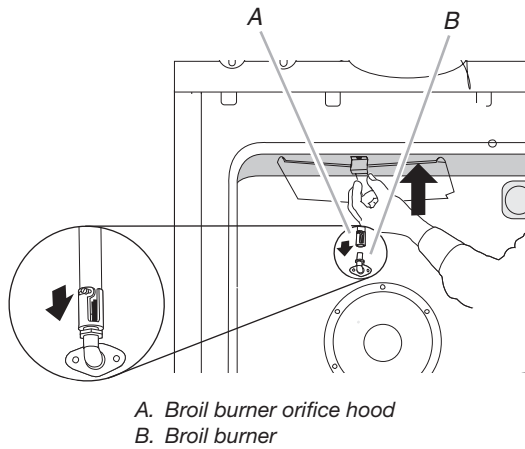

To Convert Surface Burners (Nat. gas to LP)

- If the burner grates are installed, remove them.
- Remove the burner caps.
- Using a Phillips or TORX® screwdriver, remove the burner base.

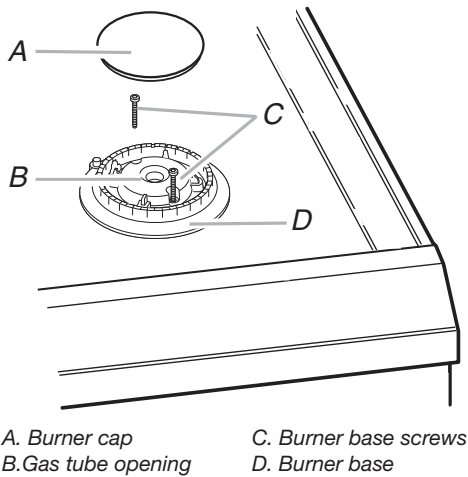

- Apply masking tape to the end of a $\frac{9}{32}$ " (7.0 mm) nut driver to help hold the Natural gas orifice spud in the nut driver while changing it. Press nut driver down onto the Natural gas orifice spud and remove by turning it counterclockwise and lifting out. Set the Natural gas orifice spud aside.

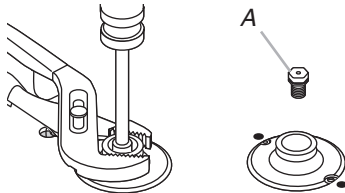

Use the following chart for correct LP gas orifice spud for each burner. Refer to the model/serial/rating plate behind the control panel for proper sizing of LP gas orifice spuds for each burner location.

LP Gas Orifice Spud Chart

| Burner Rating | Color | Number |
|---------------|-------|--------|
| 4,000 BTU | Blue | 64L |
| 7,000 BTU | Black | 81L |
| 9,100 BTU | Green | 97L |
| 14,000 BTU | Red | 114L |

- Replace the Natural gas orifice spud with the correct LP gas orifice spud. See the "LP Gas Orifice Spud Chart."
- Replace burner base and hand tighten the screws.
- Replace burner cap.
- Repeat steps 1 through 7 for the remaining burners.
- Place Natural gas orifice spuds in plastic parts bag for future use and keep with literature package.
- Replace burner grates.
- Complete installation. See the "Make Gas Connection" and "Electronic Ignition System" sections.

Checking for proper cooktop burner flame is very important. The small inner cone should have a very distinct blue flame $\frac{1}{4}$ " to $\frac{1}{2}$ " long. The outer cone is not as distinct as the inner cone. LP gas flames have a slightly yellow tip.

IMPORTANT: You may have to adjust the LO setting for each cooktop burner. See "Adjust Flame Height" in the "Electronic Ignition System" section.

Natural Gas Conversion

! WARNING



Tip Over Hazard

A child or adult can tip the range and be killed.

Install anti-tip bracket to floor or wall per installation instructions.

Slide range back so rear range foot is engaged in the slot of the anti-tip bracket.

Re-engage anti-tip bracket if range is moved.

Do not operate range without anti-tip bracket installed and engaged.

Failure to follow these instructions can result in death or serious burns to children and adults.

- Turn manual shut-off valve to the closed position.

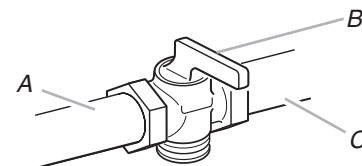

- Unplug range or disconnect power.

To Convert Gas Pressure Regulator

1. Locate gas pressure regulator at the rear of the range.

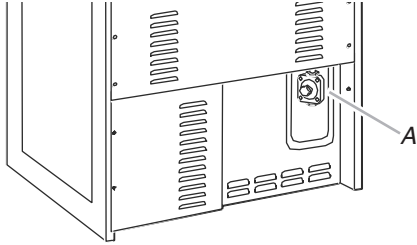

A. Gas pressure regulator

IMPORTANT: Do not remove the gas pressure regulator.

2. Unscrew the regulator cap and remove the plastic cover.

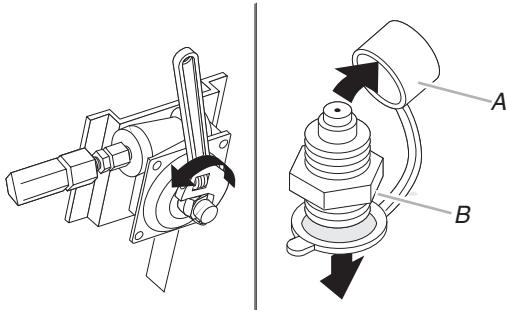

A. Plastic cover
B. Regulator cap

3. Flip the regulator cap over and replace the plastic cover.

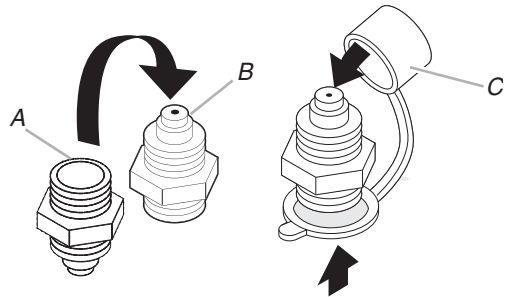

A. LP gas position
B. Natural gas position
C. Plastic cover

4. Screw the regulator cap securely back into place. Do not overtighten.

To Convert Oven Bake Burners

To Convert Lower Oven Bake Burner:

1. Remove oven racks from inside the oven cavity.
2. Remove oven door. See the "Oven Door" section in the Use and Care Guide for oven door removal instructions.

3. Push the bake burner cover to the right.

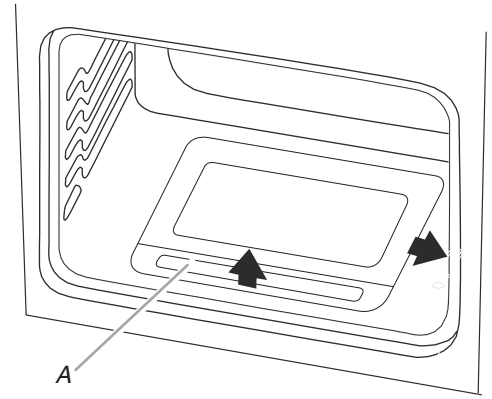

A. Bake burner cover

4. Lift up and remove oven bake burner cover.
5. Unscrew wing nut and remove oven baffle.

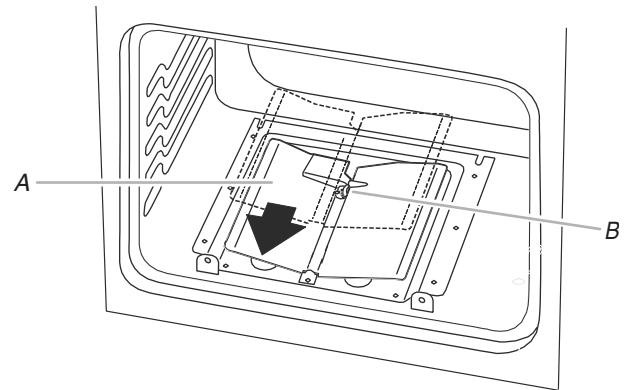

A. Oven baffle
B. Wing nut

6. Remove the oven bake burner screw and set aside.
7. Gently set the bake burner to the side.

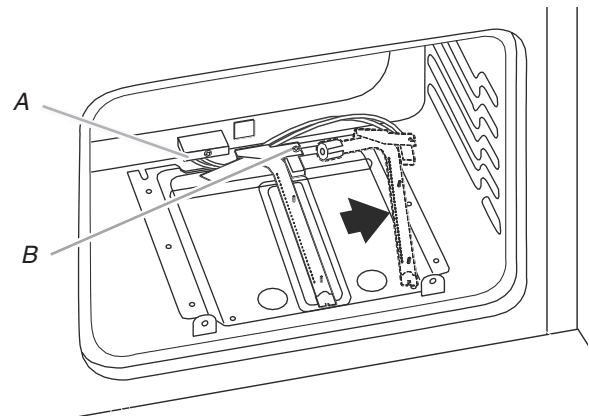

A. Igniter and wires
B. Bake burner screw

8. Unscrew and remove the cover over the orifice.

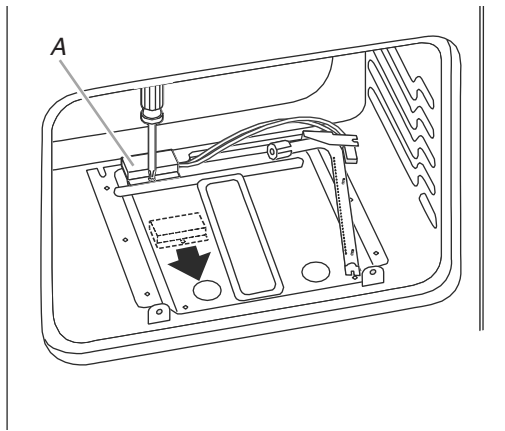

A Orifice cover

9. Turn the Number 0.044 LP gas orifice hood counterclockwise to remove.

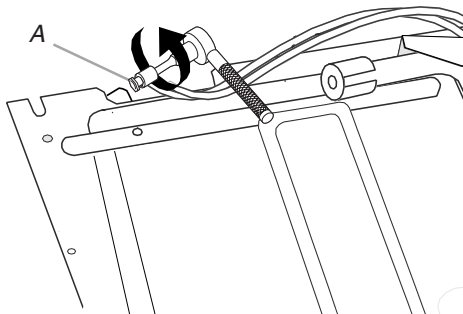

A. Number 0.044 LP gas orifice hood

10. Install the Number 0.070 Natural gas orifice hood, turning it clockwise 4 or 5 turns. Do not overtighten.

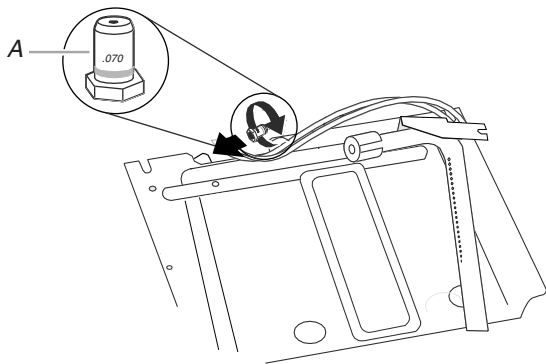

A. Number 0.070 Natural gas orifice hood

11. Position the oven bake burner over the orifice hood and reinstall using screw.

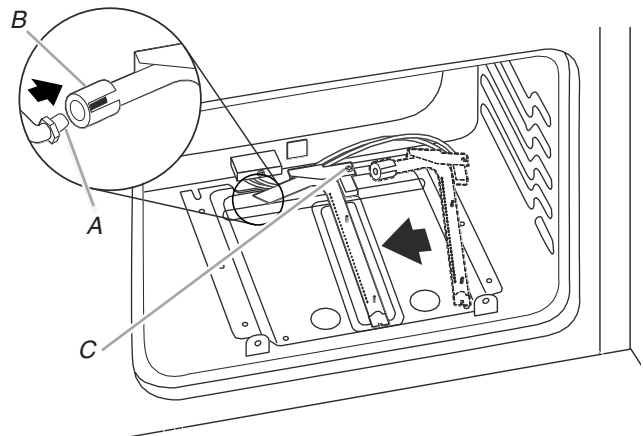

A. Bake burner orifice hood
B. Oven bake burner
C. Oven bake burner screw

To Convert Upper Oven Bake Burner

12. Repeat steps 1 through 8 above for conversion of the upper oven bake burner.
13. Remove the Number 0.037 LP gas orifice spud in the upper oven and replace with a Number 0.055 Natural gas orifice spud.
14. Reverse steps to reinstall the orifice covers, oven bake burners, oven baffles, and oven bake covers in both ovens.

To Convert Oven Broil Burner

1. Remove broil burner screw and set aside.
2. Remove the broil burner from the broil burner orifice hood. The broil burner will hang in the back of the oven while changing the orifice hood.

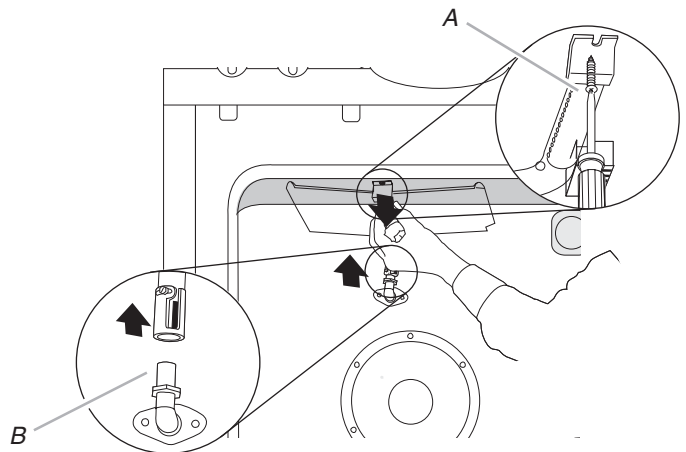

A. Broil burner screw
B. Broil burner orifice hood

- Turn the green Number 0.037 LP gas broil burner orifice hood counter clockwise to remove.

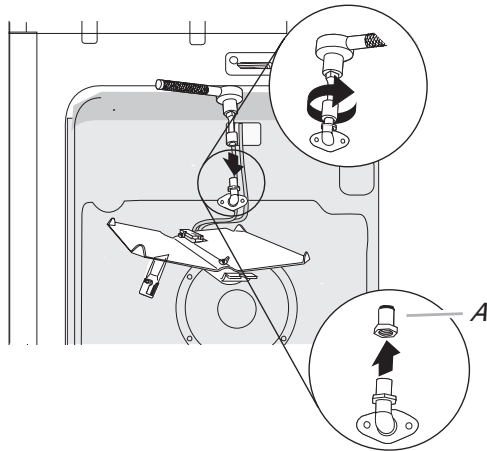

A. Number 0.037 LP gas broil burner orifice hood

- Install the Number 0.054 Natural gas broil burner orifice hood, turning it clockwise 4 or 5 turns. Do not overtighten.

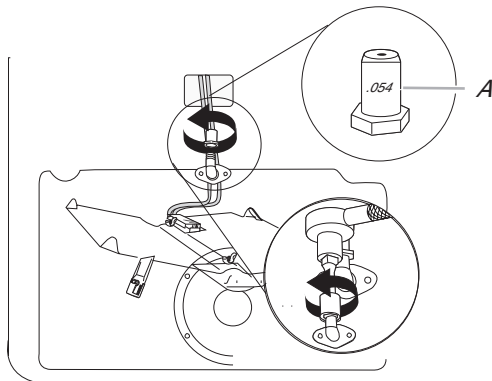

A. Number 0.054 Natural gas broil burner orifice hood

- Place the broil burner on the broil burner orifice hood. Insert the broil burner locator pin in the hole in the oven back.
- Position the broil burner against the roof of the oven cavity and attach with screw.

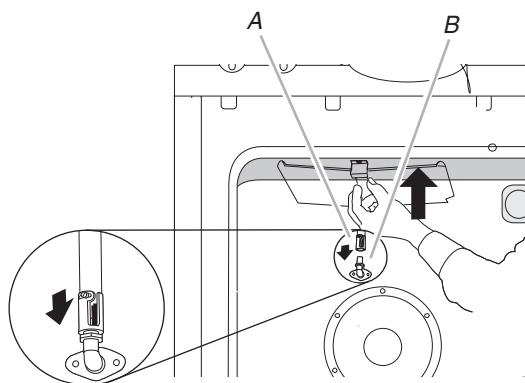

A. Broil burner orifice hood
B. Broil burner

To Convert Surface Burners (LP to Nat. gas)

- If the burner grates are installed, remove them.
- Remove the burner caps.

- Using a Phillips or TORX® screwdriver, remove the burner base.

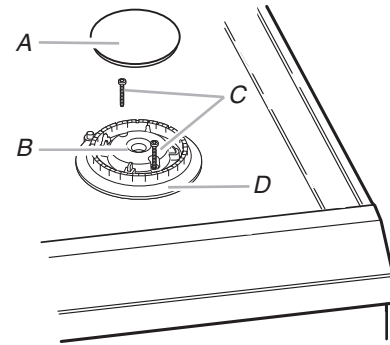

A. Burner cap
B. Gas tube opening
C. Burner base screws
D. Burner base

- Apply masking tape to the end of a $\frac{9}{32}$ " (7.0 mm) nut driver to help hold the LP gas orifice spud in the nut driver while changing it. Press nut driver down onto the LP gas orifice spud and remove by turning it counterclockwise and lifting out. Set the LP gas orifice spud aside.

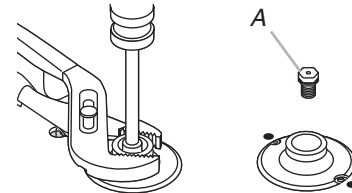

A. LP gas orifice spud

Use the following chart for correct Natural gas orifice spud for each burner. Refer to the model/serial/rating plate behind the control panel for proper sizing of Natural orifice spuds for each burner location.

Natural Gas Orifice Spud Chart

| Burner Rating | Color | Number |
|---------------|--------|--------|
| 5,000 BTU | Green | 107N |
| 7,300 BTU | Yellow | 125N |
| 9,200 BTU | Orange | 142N |
| 10,000 BTU | Clear | 149N |
| 15,000 BTU | White | 180N |
| 16,000 BTU | Black | 195N |

- Replace the LP gas orifice spud with correct Natural gas orifice spud. See the "Natural Gas Orifice Spud Chart."
- Replace burner base and hand tighten the screws.
- Replace burner cap.
- Repeat steps 1 through 7 for the remaining burners.
- Place LP gas orifice spuds in plastic parts bag for future use and keep with literature package.
- Replace burner grates.
- Complete installation. See the "Make Gas Connection" and "Electronic Ignition System" sections. Checking for proper cooktop burner flame is very important. The small inner cone should have a very distinct blue flame $\frac{1}{4}$ " to $\frac{1}{2}$ " long. The outer cone is not as distinct as the inner cone. Natural gas flames do not have yellow tips.

IMPORTANT: You may have to adjust the LO setting for each cooktop burner. See "Adjust Flame Height" in the "Electronic Ignition System" section.

