

# INSTALLATION INSTRUCTIONS 30" (76.2 CM) FREESTANDING ELECTRIC RANGE WITH DOUBLE OVENS

## INSTRUCTIONS D'INSTALLATION POUR CUISINIÈRE ÉLECTRIQUE AUTOPORTANTE AVEC FOURS DOUBLES DE 30" (76,2 CM)

### Table of Contents/Table des matières

RANGE SAFETY .....	1	SÉCURITÉ DE LA CUISINIÈRE .....	14
INSTALLATION REQUIREMENTS.....	2	EXIGENCES D'INSTALLATION .....	15
Tools and Parts.....	2	Outils et pièces.....	15
Location Requirements.....	2	Exigences d'emplacement.....	15
Electrical Requirements - U.S.A. Only.....	4	Spécifications électriques.....	17
Electrical Requirements - Canada Only.....	5	<b>INSTRUCTIONS D'INSTALLATION .....</b>	<b>17</b>
<b>INSTALLATION INSTRUCTIONS.....</b>	<b>5</b>	Déballage de la cuisinière .....	17
Unpack Range.....	5	Réglage des pieds de nivellement.....	17
Adjust Leveling Legs .....	5	Installation de la bride antibasculement .....	18
Install Anti-Tip Bracket.....	6	Vérifier que la bride antibasculement	
Electrical Connection - U.S.A. Only.....	7	est bien installée et engagée .....	18
Verify Anti-Tip Bracket Is Installed and Engaged .....	12	Réglage de l'aplomb de la cuisinière.....	19
Level Range.....	12	Achever l'installation .....	20
Complete Installation .....	13	Déplacement de la cuisinière .....	20
Moving the Range.....	13		

## RANGE SAFETY

### Your safety and the safety of others are very important.

We have provided many important safety messages in this manual and on your appliance. Always read and obey all safety messages.



This is the safety alert symbol.

This symbol alerts you to potential hazards that can kill or hurt you and others.

All safety messages will follow the safety alert symbol and either the word "DANGER" or "WARNING."

These words mean:

**⚠ DANGER**

You can be killed or seriously injured if you don't immediately follow instructions.

**⚠ WARNING**

You can be killed or seriously injured if you don't follow instructions.

All safety messages will tell you what the potential hazard is, tell you how to reduce the chance of injury, and tell you what can happen if the instructions are not followed.

### IMPORTANT:

Save for local electrical inspector's use.

### IMPORTANT :

À conserver pour consultation par l'inspecteur local des installations électriques.

## ⚠ WARNING

### Tip Over Hazard

A child or adult can tip the range and be killed.

Install anti-tip bracket to floor or wall per installation instructions.

Slide range back so rear range foot is engaged in the slot of the anti-tip bracket.

Re-engage anti-tip bracket if range is moved.

Do not operate range without anti-tip bracket installed and engaged.

Failure to follow these instructions can result in death or serious burns to children and adults.

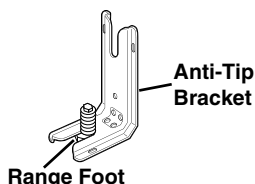
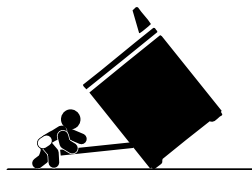

To verify the anti-tip bracket is installed and engaged:

- Slide range forward.
- Look for the anti-tip bracket securely attached to floor or wall.
- Slide range back so rear range foot is under anti-tip bracket.
- See installation instructions for details.

## INSTALLATION REQUIREMENTS

### Tools and Parts

Gather the required tools and parts before starting installation. Read and follow the instructions provided with any tools listed here.

#### Tools Needed

- Tape measure
- Level
- Phillips screwdriver
- Flat-blade screwdriver
- Wrench or pliers
- $\frac{3}{8}$ " nut driver
- Hand or electric drill
- $\frac{1}{8}$ " (3.2 mm) drill bit

#### Parts supplied

Check that all parts are included.

- 3 - 10-32 hex nuts (attached to terminal block)
- 3 - Terminal lugs
- Oven racks
- 2 - #12 x  $1\frac{5}{8}$ " screws (for mounting anti-tip bracket)
- Anti-tip bracket (taped inside upper oven with package containing literature)

Anti-tip bracket must be securely mounted to back wall or floor. Thickness of floor may require longer screws to anchor bracket to subfloor. Longer screws are available from your local hardware store.

#### Parts needed

If using a power supply cord:

- A UL Listed power supply cord kit marked for use with ranges. The cord should be rated at 250 volts minimum, 40 amps or 50 amps that is marked for use with nominal  $1\frac{3}{8}$ " (3.5 cm) diameter connection opening and must end in ring terminals or open-end spade terminals with upturned ends.
- A UL Listed strain relief.

Check local codes. Check existing electrical supply. See the "Electrical Requirements" section.

It is recommended that all electrical connections be made by a licensed, qualified electrical installer.

### Location Requirements

**IMPORTANT:** Observe all governing codes and ordinances.

- It is the installer's responsibility to comply with installation clearances specified on the model/serial/rating plate. The model/serial/rating plate is located behind the control panel.
- To eliminate the risk of burns or fire by reaching over heated surface units, cabinet storage space located above the surface units should be avoided. If cabinet storage is to be provided, the risk can be reduced by installing a range hood that projects horizontally a minimum of 5" (12.7 cm) beyond the bottom of the cabinets.
- Cabinet opening dimensions that are shown must be used. Given dimensions are minimum clearances.
- The floor anti-tip bracket must be installed. To install the anti-tip bracket shipped with the range, see the "Install Anti-Tip Bracket" section.
- Grounded electrical supply is required. See the "Electrical Requirements" section.

**IMPORTANT:** To avoid damage to your cabinets, check with your builder or cabinet supplier to make sure that the materials used will not discolor, delaminate or sustain other damage. This range has been designed in accordance with the requirements of UL and CSA International and complies with the maximum allowable wood cabinet temperatures of 194°F (90°C).

#### Mobile Home - Additional Installation Requirements

The installation of this range must conform to the Manufactured Home Construction and Safety Standard, Title 24 CFR, Part 3280 (formerly the Federal Standard for Mobile Home Construction and Safety, Title 24, HUD Part 280). When such standard is not applicable, the Standard for Manufactured Home Installations, ANSI A225.1/NFPA 501A or with local codes.

#### Mobile home installations require:

- When this range is installed in a mobile home, it must be secured to the floor during transit. Any method of securing the range is adequate as long as it conforms to the standards listed above.
- Four-wire power supply cord or cable must be used in a mobile home installation. The appliance wiring will need to be revised. See the "Electrical Connection" section.

## Product Dimensions

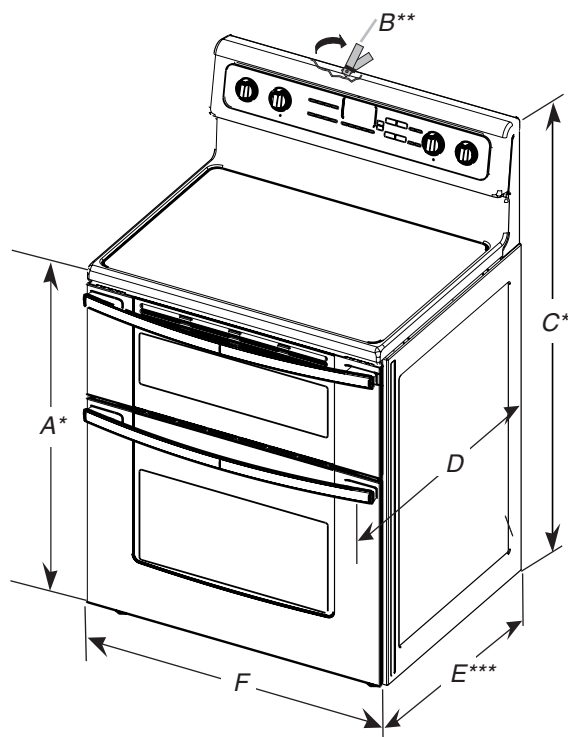

A.  $35\frac{3}{4}'' \pm \frac{1}{8}''$  (90.8 cm  $\pm$  0.3 cm) cooktop height (minimum) with leveling legs screwed all the way in\*

B. Model/serial/rating plates (located behind the control panel)\*\*

C.  $47\frac{3}{8}'' \pm \frac{1}{8}''$  (120.3 cm  $\pm$  0.3 cm) overall height (minimum) with leveling legs screwed all the way in\*

D.  $28\frac{1}{2}'' \pm \frac{1}{4}''$  (72.4 cm  $\pm$  0.6 cm) depth with handle

E.  $26\frac{1}{8}'' \pm \frac{1}{8}''$  (66.4 cm  $\pm$  0.3 cm)\*\*\*

F.  $29\frac{15}{16}'' \pm \frac{1}{16}''$  (76.0 cm  $\pm$  0.2 cm) width

\* Range can be raised approximately 1" (2.5 cm) by adjusting the leveling legs.

\*\* Model/serial/rating plates may be rotated up from behind the control panel for viewing from the front of the range.

\*\*\* Excludes handle. Dimension given is from wall to front of oven door and will vary based on electric outlet receptacle installation.

## Cabinet Dimensions

Cabinet opening dimensions shown are for 25" (63.5 cm) countertop depth, 24" (61.0 cm) base cabinet depth and 36" (91.4 cm) countertop height.

**IMPORTANT:** If installing a range hood or microwave hood combination above the range, follow the range hood or microwave hood combination installation instructions for dimensional clearances above the cooktop surface.

A freestanding range may be installed next to combustible walls with zero clearance.

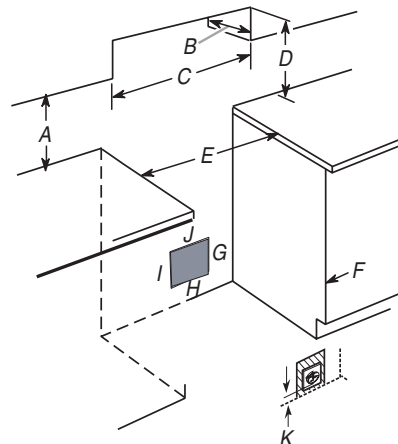

A. 18" (45.7 cm) upper cabinet to countertop

B. 13" (33.0 cm) upper cabinet depth

C. 30" (76.2 cm) min. opening width.

D. For minimum clearance to the top of the cooktop, see NOTE.

E. U.S.A.: 30" (76.2 cm) min. opening width  
Canada: 31" (78.7 cm) min. opening width

F. Cabinet door or hinge should not extend into cutout\*

G.  $1\frac{1}{2}''$  (3.8 cm) min. from right side cabinet

H. 2" (5.1 cm) min. from floor

I. 7" (17.8 cm) height

J. 8" (20.3 cm) width

K.  $3\frac{1}{2}''$  (8.9 cm) min. from floor

Proper positioning of outlet shown above.

\* Nothing located in shaded areas can extend more than  $1\frac{1}{2}''$  (3.8 cm) from wall or range will not slide all the way back.

**NOTE:** 24" (61.0 cm) minimum when bottom of wood or metal cabinet is covered by not less than  $\frac{1}{4}''$  (0.64 cm) flame retardant millboard covered with not less than No. 28 MSG sheet steel, 0.015" (0.4 mm) stainless steel, 0.024" (0.6 mm) aluminum or 0.020" (0.5 mm) copper.

30" (76.2 cm) minimum clearance between the top of the cooking platform and the bottom of an uncovered wood or metal cabinet.

## Electrical Requirements - U.S.A. Only

If codes permit and a separate ground wire is used, it is recommended that a qualified electrical installer determine that the ground path and wire gauge are in accordance with local codes.

Do not use an extension cord.

Be sure that the electrical connection and wire size are adequate and in conformance with the National Electrical Code, ANSI/NFPA 70-latest edition and all local codes and ordinances.

A copy of the above code standards can be obtained from:

National Fire Protection Association  
1 Batterymarch Park  
Quincy, MA 02169-7471

**WARNING:** Improper connection of the equipment-grounding conductor can result in a risk of electric shock. Check with a qualified electrician or service technician if you are in doubt as to whether the appliance is properly grounded. Do not modify the power supply cord plug. If it will not fit the outlet, have a proper outlet installed by a qualified electrician.

### Electrical Connection

To properly install your range, you must determine the type of electrical connection you will be using and follow the instructions provided for it here.

- Range must be connected to the proper electrical voltage and frequency as specified on the model/serial rating plate. The model/serial rating plate is located behind the control panel. Refer to the figures in "Product Dimensions" in the "Location Requirements" section.
- This range is manufactured with the neutral terminal connected to the cabinet. Use a 3-wire, UL Listed, 40- or 50- amp power supply cord (pigtail) (see the following Range Rating chart). If local codes do not permit ground through the neutral, use a 4-wire power supply cord rated at 250 volts, 40- or 50-amps and investigated for use with ranges.

Range Rating*		Specified Rating of Power Supply Cord Kit and Circuit Protection
120/240 Volts	120/208 Volts	Amps
8.8 - 16.5 KW	7.8 - 12.5 KW	40 or 50**
16.6 - 22.5 KW	12.6 - 18.5 KW	50

\* The NEC calculated load is less than the total connected load listed on the model/serial rating plate.

\*\* If connecting to a 50-amp circuit, use a 50-amp rated cord with kit. For 50-amp rated cord kits, use kits that specify use with a nominal 1<sup>3</sup>/<sub>8</sub>" (34.9 mm) diameter connection opening.

- A circuit breaker is recommended.
- The range can be connected directly to the circuit breaker box (or fused disconnect) through flexible or nonmetallic sheathed, copper or aluminum cable. See the "Electrical Connection - U.S.A. Only" section.
- Allow 2 to 3 ft (61.0 cm to 91.4 cm) of slack in the line so that the range can be moved if servicing is ever necessary.
- A UL Listed conduit connector must be provided at each end of the power supply cable (at the range and at the junction box).
- Wire sizes and connections must conform with the rating of the range.
- The wiring diagram is located on the Tech Sheet.
- The Tech Sheet is located on the back of the range inside a clear plastic bag.

### If connecting to a 4-wire system:

This range is manufactured with the ground connected to the neutral by a link. The ground must be revised so the green ground wire of the 4-wire power supply cord is connected to the cabinet. See the "Electrical Connection - U.S.A. Only" section.

Grounding through the neutral conductor is prohibited for new branch-circuit installations (1996 NEC); mobile homes; and recreational vehicles, or an area where local codes prohibit grounding through the neutral conductor.

When a 4-wire receptacle of NEMA Type 14-50R is used, a matching UL Listed, 4-wire, 250-volt, 40- or 50-amp, range power supply cord (pigtail) must be used. This cord contains 4 copper conductors with ring terminals or open-end spade terminals with upturned ends, terminating in a NEMA Type 14-50P plug on the supply end.

The fourth (grounding) conductor must be identified by a green or green/yellow cover and the neutral conductor by a white cover. Cord should be Type SRD or SRDT with a UL Listed strain relief and be at least 4 ft (1.22 m) long.

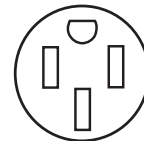

4-wire receptacle (14-50R)

The minimum conductor sized for the copper 4-wire power cord are:

- 40-amp circuit
- 2 No.-8 conductors
- 1 No.-10 white neutral
- 1 No.-10 green grounding

### If connecting to a 3-wire system:

Local codes may permit the use of a UL Listed, 3-wire, 250-volt, 40- or 50-amp range power supply cord (pigtail). This cord contains 3 copper conductors with ring terminals or open-end spade terminals with upturned ends, terminating in a NEMA Type 10-50P plug on the supply end. Connectors on the appliance end must be provided at the point the power supply cord enters the appliance. This uses a 3-wire receptacle of NEMA Type 10-50R.

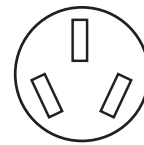

3-wire receptacle (10-50R)

## Electrical Requirements - Canada Only

### **⚠ WARNING**



#### **Electrical Shock Hazard**

**Electrically ground range.**

**Failure to do so can result in death, fire, or electrical shock.**

If codes permit and a separate ground wire is used, it is recommended that a qualified electrical installer determine that the ground path is adequate and wire gauge are in accordance with local codes.

Be sure that the electrical connection and wire size are adequate and in conformance with CSA Standard C22.1, Canadian Electrical Code, Part 1 - latest edition, and all local codes and ordinances.

A copy of the above code standards can be obtained from:

Canadian Standards Association  
178 Rexdale Blvd.  
Toronto, ON M9W 1R3 CANADA

- Check with a qualified electrical installer if you are not sure the range is properly grounded.

Range Rating*	Specified Rating of Power Supply Cord Kit and Circuit Protection	
	120/240 Volts	120/208 Volts
8.8 - 16.5 KW	7.8 - 12.5 KW	40 or 50**
16.6 - 22.5 KW	12.6 - 18.5 KW	50

\*The NEC calculated load is less than the total connected load listed on the model/serial/rating plate.

\*\* If connecting to a 50-amp circuit, use a 50-amp rated cord with kit. For 50-amp rated cord kits, use kits that specify use with a nominal 1<sup>3</sup>/<sub>8</sub>" (34.9 mm) diameter connection opening.

- A time-delay fuse or circuit breaker is recommended.
- This range is equipped with a CSA International Certified Power Cord intended to be plugged into a standard 14-50R wall receptacle. Be sure the wall receptacle is within reach of range's final location.

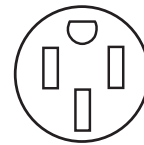

- Do not use an extension cord.

## INSTALLATION INSTRUCTIONS

### Unpack Range

### **⚠ WARNING**

#### **Excessive Weight Hazard**

**Use two or more people to move and install range.**

**Failure to do so can result in back or other injury.**

1. Remove shipping materials, tape and film from the range. Keep cardboard bottom under range.
2. Remove oven racks and parts package from inside oven.
3. To place range on its back, take 4 cardboard corners from the carton. Stack one cardboard corner on top of another. Repeat with the other 2 corners. Place them lengthwise on the floor behind the range to support the range when it is laid on its back.
4. Using 2 or more people, firmly grasp the range and gently lay it on its back on the cardboard corners.
5. Pull cardboard bottom firmly to remove.
6. Use an adjustable wrench to loosen the leveling legs.
7. Place cardboard or hardboard in front of range. Using 2 or more people, stand range back up onto cardboard or hardboard.

### Adjust Leveling Legs

1. If range height adjustment is necessary, use a wrench or pliers to loosen the 4 leveling legs.  
This may be done with the range on its back or with the range supported on 2 legs after the range has been placed back to a standing position.  
**NOTE:** To place range back up into a standing position, put a sheet of cardboard or hardboard in front of range. Using 2 or more people, stand range back up onto the cardboard or hardboard.
2. Adjust the leveling legs to the correct height. Leveling legs can be loosened to add up to a maximum of 1" (2.5 cm). A minimum of <sup>3</sup>/<sub>16</sub>" (5.0 mm) is needed to engage the anti-tip bracket.  
**NOTE:** If height adjustment is made when range is standing, tilt the range back to adjust the front legs, then tilt forward to adjust the rear legs.
3. When the range is at the correct height, check that there is adequate clearance under the range for the anti-tip bracket. Before sliding range into its final location, check that the anti-tip bracket will slide under the range and onto the rear leveling leg prior to anti-tip bracket installation.

## Install Anti-Tip Bracket

### **WARNING**



#### Tip Over Hazard

**A child or adult can tip the range and be killed.**

**Install anti-tip bracket to floor or wall per installation instructions.**

**Slide range back so rear range foot is engaged in the slot of the anti-tip bracket.**

**Re-engage anti-tip bracket if range is moved.**

**Do not operate range without anti-tip bracket installed and engaged.**

**Failure to follow these instructions can result in death or serious burns to children and adults.**

1. Remove the anti-tip bracket that is taped inside the upper oven with the package containing literature.
2. Determine which mounting method to use: floor or wall. If you have a stone or masonry floor, you can use the wall mounting method.

3. Determine and mark edge of range in the cutout space. The mounting bracket can be installed on either the left side or right side of the cutout. Position mounting bracket in cutout so that right (or left) edge of the bracket is  $1\frac{5}{16}$ " (2.4 cm) from the marked edge of the range, as shown.

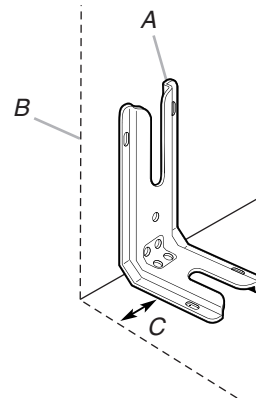

- A. Anti-tip bracket  
 B. Mark edge of range.  
 C.  $1\frac{5}{16}$ " (2.4 cm)

4. Drill two  $\frac{1}{8}$ " (3.0 mm) holes that correspond to the bracket holes of the determined mounting method. See the following illustrations.

#### Floor Mounting

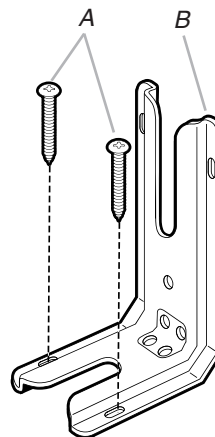

- A. #12 x  $1\frac{5}{8}$ " screws  
 B. Anti-tip bracket

#### Wall Mounting

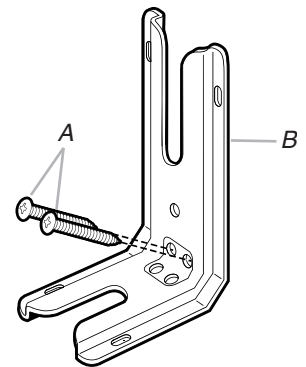

- A. #12 x  $1\frac{5}{8}$ " screws  
 B. Anti-tip bracket

5. Using a Phillips screwdriver, mount anti-tip bracket to the wall or floor with the two #12 x  $1\frac{5}{8}$ " screws provided.



# Electrical Connection - U.S.A. Only

## Power Supply Cord

### **⚠ WARNING**



#### Electrical Shock Hazard

Disconnect power before servicing.

Use a new 40 amp power supply cord.

Plug into a grounded outlet.

Failure to follow these instructions can result in death, fire, or electrical shock.

## Direct Wire

### **⚠ WARNING**



#### Electrical Shock Hazard

Disconnect power before servicing.

Use 8 gauge copper or 6 gauge aluminum wire.

Electrically ground range.

Failure to follow these instructions can result in death, fire, or electrical shock.

1. Disconnect power.
2. Use Phillips screwdriver to remove the terminal block cover screw located on the back of the range. Pull cover down and toward you to remove cover.

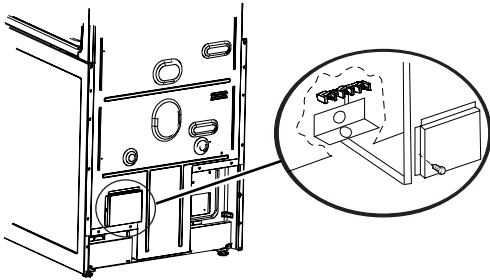

3. Remove plastic tag holding three 10-32 hex nuts from the middle post of the terminal block.

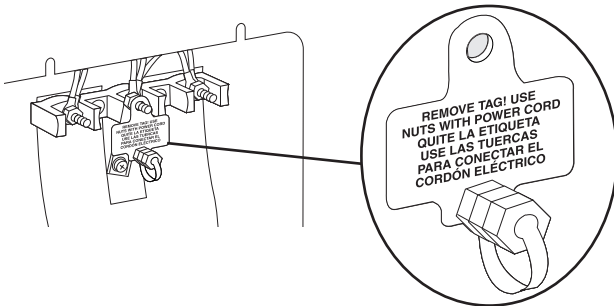

4. Add strain relief.

### Style 1: Power supply cord strain relief

- Assemble a UL Listed strain relief in the opening.

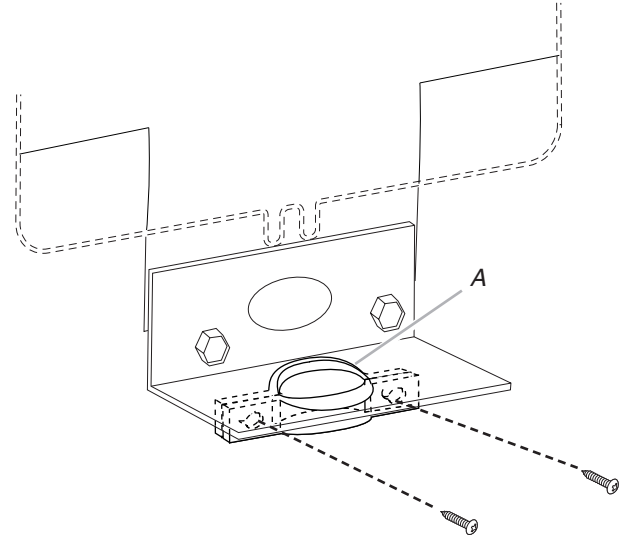

A. UL Listed strain relief

- Feed the power supply cord through the strain relief in the cord/conduit plate on bottom of range. Allow enough slack to easily attach the wiring to the terminal block.
- Tighten strain relief screw against the power supply cord.

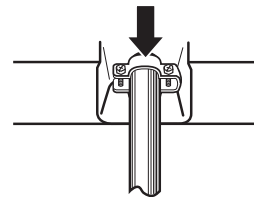

**Style 2: Direct wire strain relief**

- Use Phillips screwdriver to remove screws and slide cord/conduit plate down and out.

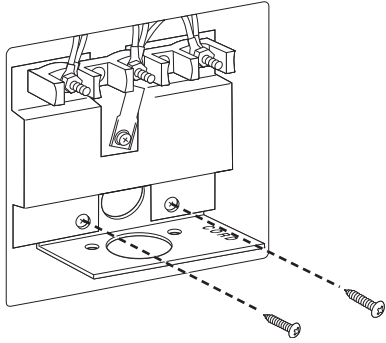

- Position cord/conduit plate as shown in the following illustration.

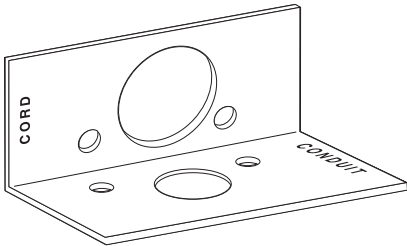

- Replace cord/conduit plate and insert screws.

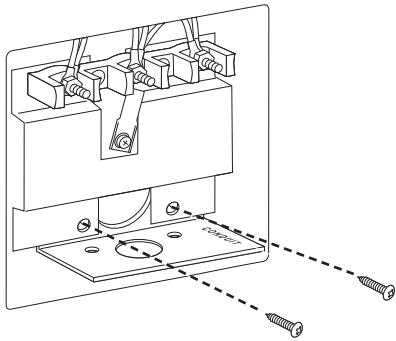

- Assemble a UL Listed conduit connector in the opening.

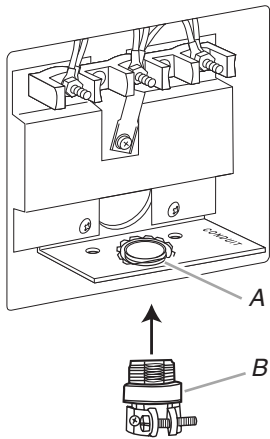

A. Removable retaining nut  
B. Strain relief

- Feed the flexible conduit through the strain relief, allowing enough slack to easily attach wiring to the terminal block.
- Tighten strain relief screw against the flexible conduit.



5. Replace back panel and screws on rear of range.
6. Complete installation following instructions for your type of electrical connection:
  - 4-wire** (recommended)
  - 3-wire** (if 4-wire is not available)

**Electrical Connection Options**

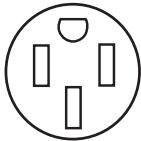
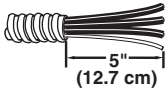
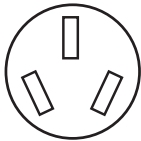
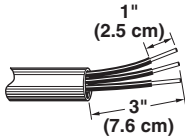
If your home has:	And you will be connecting to:	Go to Section:
4-wire receptacle (NEMA type 14-50R) 	A UL Listed, 250-volt minimum, 40-amp, range power supply cord	4-wire connection: Power Supply Cord
4-wire direct 	A fused disconnect or circuit breaker box	4-wire Connection: Direct Wire
3-wire receptacle (NEMA type 10-50R) 	A UL Listed, 250-volt minimum, 40-amp, range power supply cord	3-wire connection: Power Supply Cord
3-wire direct 	A fused disconnect or circuit breaker box	3-wire connection: Direct Wire



## 4-wire connection: Power Supply Cord

Use this method for:

- New branch-circuit installations (1996 NEC)
  - Mobile homes
  - Recreational vehicles
  - In an area where local codes prohibit grounding through the neutral
1. Part of metal ground strap must be cut out and removed.

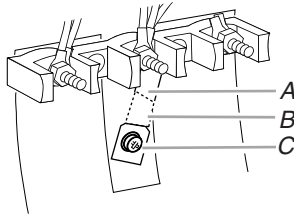

A. Metal ground strap  
B. Discard  
C. Ground-link screw

2. Use Phillips screwdriver to remove the ground-link screw from the back of the range. Save the ground-link screw and the end of the ground link under the screw.
3. Feed the power supply cord through the strain relief in the cord/conduit plate on bottom of range. Allow enough slack to easily attach the wiring to the terminal block.

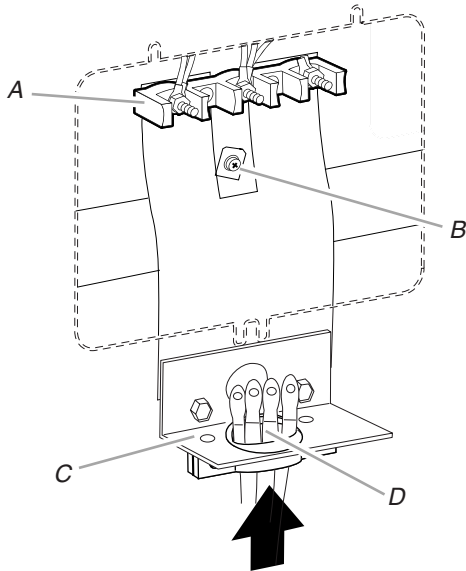

A. Terminal block  
B. Ground-link screw  
C. Cord/conduit plate  
D. Power supply cord wires

4. Use Phillips screwdriver to connect the green ground wire from the power supply cord to the range with the ground-link screw. The ground wire must be attached first.

5. Use  $\frac{3}{8}$ " nut driver to connect the neutral (white) wire to the center terminal block post with one of the 10-32 hex nuts.

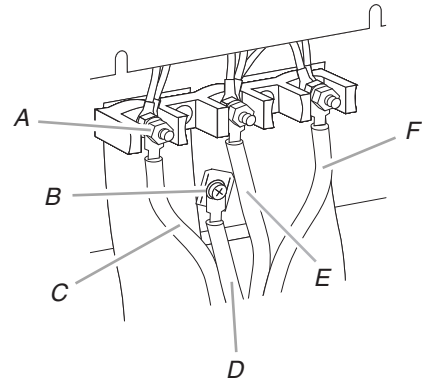

A. 10-32 hex nut  
B. Ground-link screw  
C. Line 1 (black)  
D. Green ground wire  
E. Neutral (center) wire  
F. Line 2 (red)

6. Connect line 1 (black) and line 2 (red) wires to the outer terminal block posts with 10-32 hex nuts.
7. Securely tighten hex nuts.

**NOTE:** For power supply cord replacement, only use a power cord rated at 250 volts minimum, 40 amps or 50 amps that is marked for use with nominal  $1\frac{3}{8}$ " (3.5 cm) diameter connection opening, with ring terminals and marked for use with ranges.

8. Replace terminal block access cover.
9. Slide range back so rear range foot is under the anti-tip bracket. See the "Verify Anti-Tip Bracket is Installed and Engaged" section.

## 3-wire connection: Power Supply Cord

Use this method only if local codes permit connecting chassis ground conductor to neutral wire of power supply cord.

1. Feed the power supply cord through the strain relief in the cord/conduit plate on bottom of range. Allow enough slack to easily attach the wiring to the terminal block.

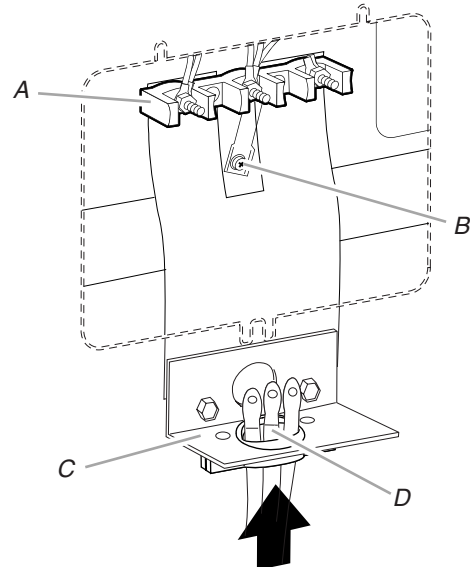

A. Terminal block  
B. Ground-link screw  
C. Cord/conduit plate  
D. Power supply cord wires

- Use  $\frac{3}{8}$ " nut driver to connect the neutral (white) wire to the center terminal block post with one of the 10-32 hex nuts.

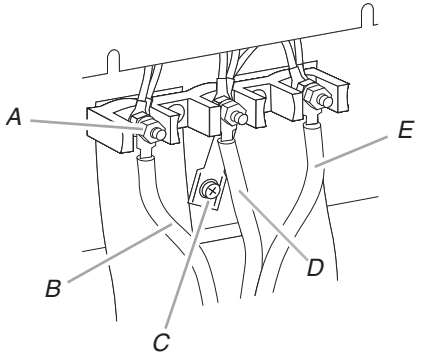

A. 10-32 hex nut      D. Neutral (white) wire  
 B. Line 1 (black)      E. Line 2 (red)  
 C. Ground-link screw

- Connect line 1 (black) and line 2 (red) wires to the outer terminal block posts with 10-32 hex nuts.
- Securely tighten hex nuts.

**NOTE:** For power supply cord replacement, only use a power cord rated at 250 volts minimum, 40 amps or 50 amps that is marked for use with nominal  $1\frac{3}{8}$ " (3.5 cm) diameter connection opening, with ring terminals and marked for use with ranges.

- Replace terminal block access cover.
- Slide range back so rear range foot is under the anti-tip bracket. See the "Verify Anti-Tip Bracket is Installed and Engaged" section.

### Direct Wire Installation: Copper or Aluminum Wire

This range may be connected directly to the fuse disconnect or circuit breaker box. Depending on your electrical supply, make the required 3-wire or 4-wire connection.

- Strip outer covering back 3" (7.6 cm) to expose wires. Strip the insulation back 1" (2.5 cm) from the end of each wire.

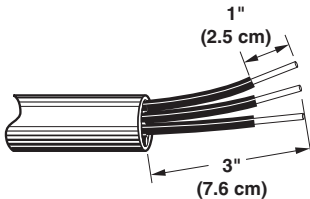

- Allow enough slack in the wire to easily attach the wiring terminal block.
- Complete electrical connection according to your type of electrical supply (4-wire or 3-wire connection).

### 4-wire Connection: Direct Wire

Use this method for:

- New branch-circuit installations (1996 NEC)
  - Mobile homes
  - Recreational vehicles
  - In an area where local codes prohibit grounding through the neutral
- Part of metal ground strap must be cut out and removed.

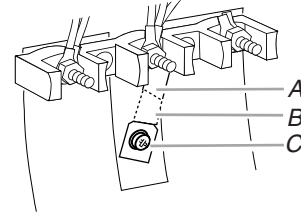

A. Metal ground strap  
 B. Discard  
 C. Ground-link screw

- Use Phillips screwdriver to remove the ground-link screw from the back of the range. Save the ground-link screw and the end of the ground link under the screw.
- Pull the conduit through the strain relief on cord/conduit plate. Allow enough slack to easily attach wiring to the terminal block.

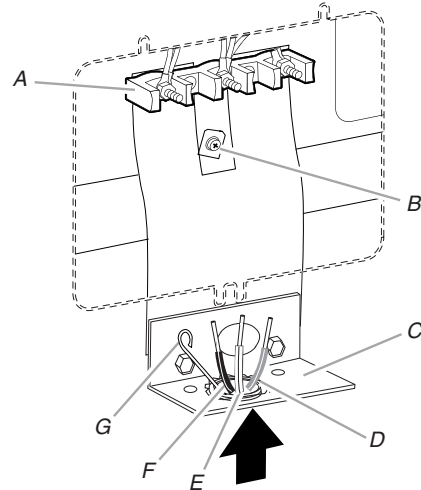

A. Terminal block      E. Neutral (white) wire  
 B. Ground-link screw      F. Line 1 (black) wire  
 C. Cord/conduit plate      G. Bare (green) ground wire  
 D. Line 2 (red) wire

- Attach terminal lugs to line 1 (black), neutral (white), and line 2 (red) wires. Loosen (do not remove) the setscrew on the front of the terminal lug and insert exposed wire end through bottom of terminal lugs. Securely tighten setscrew to XX lbs-in. torque. See Bare Wire Torque Specifications chart.

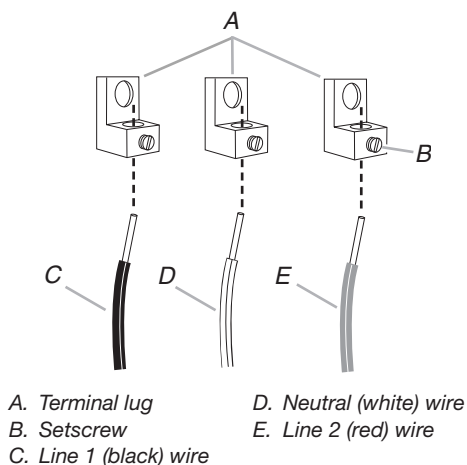

### Bare Wire Torque Specifications

Attaching terminal lugs to the terminal block - 20 lbs-in. (2.3 N-m)

Wire Awg	Torque
8 gauge copper	25 lbs-in. (2.8 N-m)
6 gauge aluminum	35 lbs-in. (4.0 N-m)

- Use Phillips screwdriver to connect the bare (green) ground wire to the range with the ground-link screw. The ground wire must be attached first and must not contact any other terminal.
- Use  $\frac{3}{8}$ " nut driver to connect the neutral (white) wire to the center terminal block post with one of the 10-32 hex nuts.

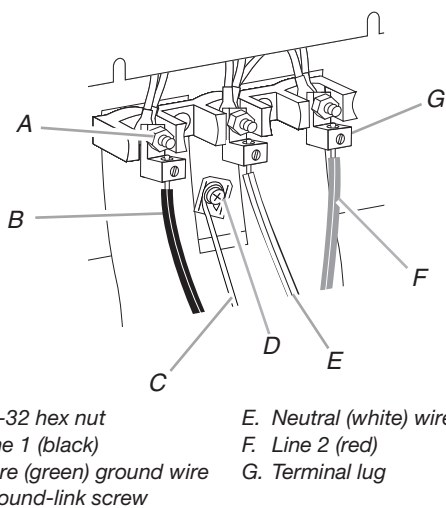

- Connect line 1 (black) and line 2 (red) wires to the outer terminal block posts with 10-32 hex nuts.
- Securely tighten hex nuts.
- Replace terminal block access cover.
- Slide range back so rear range foot is under the anti-tip bracket. See the "Verify Anti-Tip Bracket is Installed and Engaged" section.

### 3-wire connection: Direct Wire

Use this method only if local codes permit connecting ground conductor to neutral supply wire.

- Pull the conduit through the hole and conduit plate on bottom of range. Allow enough slack to easily attach the wiring to the terminal block.

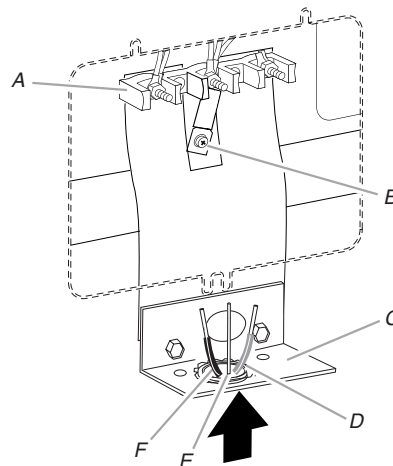

- Attach terminal lugs to line 1 (black), bare (green) ground, and line 2 (red) wires. Loosen (do not remove) the setscrew on the front of the terminal lug and insert exposed wire end through bottom of terminal lugs. Securely tighten setscrew to XX lbs-in. torque. See Bare Wire Torque Specifications chart.

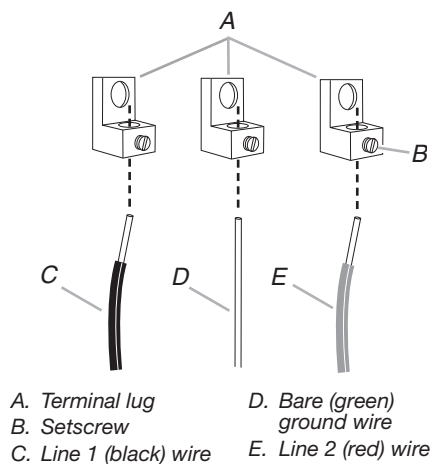

## Bare Wire Torque Specifications

Attaching terminal lugs to the terminal block - 20 lbs-in. (2.3 N-m)

Wire Awg	Torque
8 gauge copper	25 lbs-in. (2.8 N-m)
6 gauge aluminum	35 lbs-in. (4.0 N-m)

- Use  $\frac{3}{8}$ " nut driver to connect the bare (green) ground wire to the center terminal block post with one of the 10-32 hex nuts.

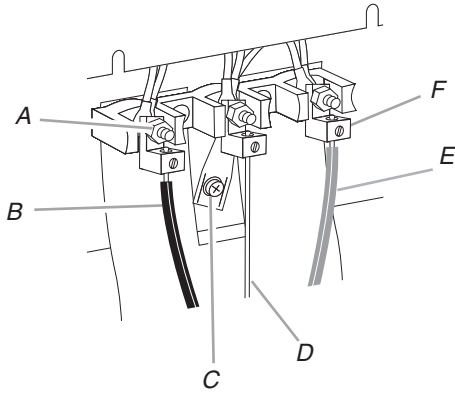

- A. 10-32 hex nut  
 B. Line 1 (black)  
 C. Ground-link screw  
 D. Bare (green) ground wire  
 E. Line 2 (red)  
 F. Terminal lug

- Connect line 1 (black) and line 2 (red) wires to the outer terminal block posts with 10-32 hex nuts.
- Securely tighten hex nuts.
- Replace terminal block access cover.
- Slide range back so rear range foot is under the anti-tip bracket. See the "Verify Anti-Tip Bracket is Installed and Engaged" section.

## Verify Anti-Tip Bracket Is Installed and Engaged

- Place the outside of your foot against the bottom front of the oven door to keep the range from moving, and grasp the lower right or left side of the control panel as shown.

**NOTE:** If your countertop is mounted with a backsplash, it may be necessary to grasp the range higher than is shown in the illustration.

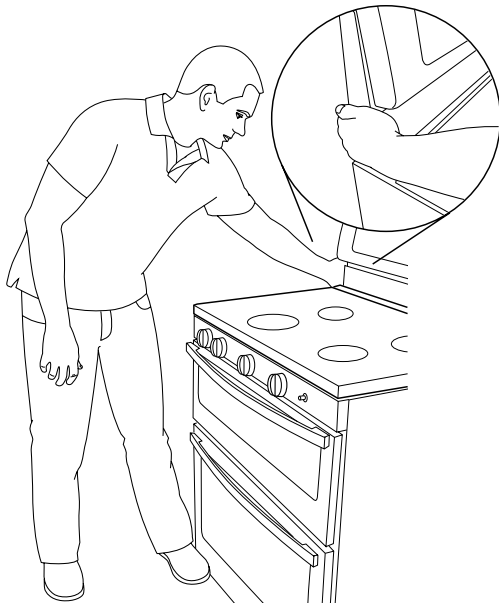

- Slowly attempt to tilt the range forward. If you encounter immediate resistance, the range foot is engaged in the anti-tip bracket.
- If the rear of the range lifts more than  $\frac{1}{2}$ " (1.3 cm) off the floor without resistance, stop tilting the range and lower it gently back to the floor. The range foot is not engaged in the anti-tip bracket.

**IMPORTANT:** If there is a snapping or popping sound when lifting the range, the range may not be fully engaged in the bracket. Check to see if there are obstructions keeping the range from sliding to the wall or keeping the range foot from sliding into the bracket. Verify that the bracket is held securely in place by the mounting screws.

- Slide the range forward, and verify that the anti-tip bracket is securely attached to the floor or wall.
- Slide range back so the rear range foot is inserted into the slot of the anti-tip bracket.

**IMPORTANT:** If the back of the range is more than 2" (5.1 cm) from the mounting wall, the rear range foot may not engage the bracket. Slide the range forward and determine if there is an obstruction between the range and the mounting wall. If you need assistance or service, refer to the "Assistance or Service" section of the Use and Care Guide, or the cover or the "Warranty" section of the User Instructions, for contact information.

- Repeat steps 1 and 2 to ensure that the range foot is engaged in the anti-tip bracket.

If the rear of the range lifts more than  $\frac{1}{2}$ " (1.3 cm) off the floor without resistance, the anti-tip bracket may not be installed correctly. Do not operate the range without anti-tip bracket installed and engaged. Please reference the "Assistance or Service" section of the Use and Care Guide, or the cover or the "Warranty" section of the User Instructions, to contact service.

## Level Range

- Place a rack in oven.
- Place level on rack and check levelness of range, first side to side; then front to back.

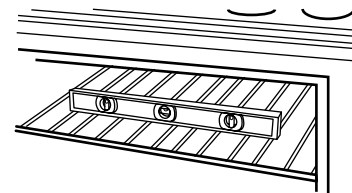

- If range is not level, pull range forward until rear leveling leg is removed from the anti-tip bracket.
- Use a wrench or pliers to adjust leveling legs up or down until the range is level. Push range back into position.
- Check that rear leveling leg is engaged in the anti-tip bracket.

**NOTE:** Range must be level for satisfactory baking performance.

## Complete Installation

1. Check that all parts are now installed. If there is an extra part, go back through the steps to see which step was skipped.
2. Check that you have all of your tools.
3. Dispose of/recycle all packaging materials.
4. Check that the range is level. See the “Level Range” section.
5. Use a mild solution of liquid household cleaner and warm water to remove waxy residue caused by shipping material. Dry thoroughly with a soft cloth. For more information, read the “Range Care” section of the Use and Care Guide.
6. Read the range Use and Care Guide.
7. Plug power cord into appropriate outlet. Slide range into its final location. Check that the flexible conduit or power supply cord are not bent.
8. Turn power on. Turn on surface elements and oven. See the Use and Care Guide for specific instruction on range operation.

### If range does not operate, check the following:

- Household fuse is intact and tight; or circuit breaker has not tripped.
- Range is plugged into a grounded outlet.
- Electrical supply is connected.
- See the “Troubleshooting” section in the Use and Care Guide.

When the range has been on for 5 minutes, check for heat. If range is cold, turn off the range and contact a qualified technician.

## Moving the Range

### ⚠ WARNING



#### Tip Over Hazard

**A child or adult can tip the range and be killed.**

**Install anti-tip bracket to floor or wall per installation instructions.**

**Slide range back so rear range foot is engaged in the slot of the anti-tip bracket.**

**Re-engage anti-tip bracket if range is moved.**

**Do not operate range without anti-tip bracket installed and engaged.**

**Failure to follow these instructions can result in death or serious burns to children and adults.**

When moving range, slide range onto cardboard or hardboard to avoid damaging the floor covering.

If removing the range is necessary for cleaning or maintenance:

### For power supply cord-connected ranges:

1. Slide range forward.
2. Unplug the power supply cord.
3. Complete cleaning or maintenance.
4. Plug power supply cord into a grounded outlet.
5. Slide range back so rear range foot is under anti-tip bracket.

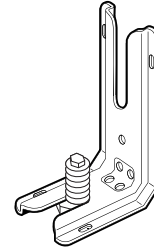

6. Refer to the “Verify Anti-Tip Bracket Is Installed and Engaged” section to verify engagement.
7. Check that range is level.

### For direct-wired ranges:

### ⚠ WARNING



#### Electrical Shock Hazard

**Disconnect power before servicing.**

**Replace all parts and panels before operating.**

**Failure to do so can result in death or electrical shock.**

1. Disconnect power.
2. Slide range forward.
3. Complete cleaning or maintenance.
4. Slide range back so rear range foot is under anti-tip bracket.

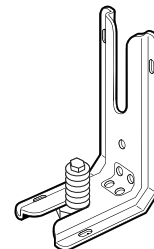

5. Refer to the “Verify Anti-Tip Bracket Is Installed and Engaged” section to verify engagement.
6. Check that range is level.
7. Reconnect power.