

Use & Care Guide
Manual de Uso y Cuidado
English / Español

Model/Modèle: 790.9771*,9772*

Kenmore Elite®

Double Oven Electric Range

Estufa de eléctrica con un doble horno

* = color number, número de color

P/N 808574611 Rev. A

Sears Brands Management Corporation
Hoffman Estates, IL 60179 U.S.A.
www.kenmore.com
www.sears.com



Table of Contents

Kenmore Elite Limited Warranty	2	Setting Oven Controls	17
Before Setting Surface Controls	8	Care and Cleaning	34
Setting Surface Controls.....	11	Porcelain enameled glide racks	37
Before Setting Oven Controls	15	Before You Call	39

Kenmore Elite Limited Warranty

When this appliance is installed, operated and maintained according to all supplied instructions, the following warranty coverage applies. To arrange for warranty service, call 1-800-4-MY-HOME® (1-800-469-4663).

U.S.A. Warranty Coverage

- One Year Limited Warranty on Appliance
For one year from the date of purchase, free repair will be provided if this appliance fails due to a defect in material or workmanship.
- Two Year Limited Warranty on Ceramic Cooktop (if equipped)
For two years from the date of purchase, if a ceramic cooktop fails due to thermal shock, or a ceramic cooktop element is defective, a free replacement part will be supplied. After the first year from purchase date, you are responsible for the labor cost of part installation.

All warranty coverage applies for only 90 days from the date of purchase if this appliance is ever used for other than private family purposes.

This warranty covers only defects in material and workmanship, and will NOT pay for:

1. Cracks in a ceramic glass cooktop that are not a result of thermal shock.
2. Stains and scratches on a ceramic glass cooktop resulting from failure to maintain it properly according to all instructions supplied with the product.
3. Consumable items that can wear out from normal use, including but not limited to filters, belts, incandescent light bulbs, and bags.
4. A service technician to instruct the user in correct product installation, operation or maintenance.
5. A service technician to clean or maintain this product.
6. Damage to or failure of this product if it is not installed, operated or maintained according to all instructions supplied with the product.
7. Damage to or failure of this product resulting from accident, abuse, misuse or use for other than its intended purpose.
8. Damage to or failure of this product caused by the use of detergents, cleaners, chemicals or utensils other than those recommended in all instructions supplied with the product.
9. Damage to or failure of parts or systems resulting from unauthorized modifications made to this product.

Disclaimer of implied warranties; limitation of remedies

Customer's sole and exclusive remedy under this limited warranty shall be product repair as provided herein. Implied warranties, including warranties of merchantability or fitness for a particular purpose, are limited to one year in the U.S. or the shortest period allowed by law. Sears shall not be liable for incidental or consequential damages. Some states do not allow the exclusion or limitation of incidental or consequential damages, or limitation on the duration of implied warranties of merchantability or fitness, so these exclusions or limitations may not apply to you.

This warranty applies only while this appliance is used in the United States.

This warranty gives you specific legal rights, and you may also have other rights which vary from state to state.

Sears Brands Management Corporation, Hoffman Estates, IL 60179

IMPORTANT SAFETY INSTRUCTIONS

Read all instructions before using this appliance.

This manual contains important safety symbols and instructions. Pay attention to these symbols and follow all instructions given.

Do not attempt to install or operate your appliance until you have read the safety precautions in this manual. Safety items throughout this manual are labeled with a WARNING or CAUTION statement based on the hazard type.

DEFINITIONS

⚠ This is the safety alert symbol. It is used to alert you to potential personal injury hazards. Obey all safety message that follow this symbol to avoid possible injury or death.

⚠ WARNING - Indicates a potentially hazardous situation which, if not avoided, may result in death or serious injury.

⚠ CAUTION - Indicates a potentially hazardous situation which, if not avoided, may result in minor or moderate injury.

Important: Indicates installation, operation, maintenance, or valuable information not hazard related.

⚠ WARNING Storage in or on appliance: Flammable materials should not be stored in an oven. This includes paper, plastic, and cloth items, such as cookbooks, plastic ware, and towels, as well as flammable liquids. Do not store explosives, such as aerosol cans, on or near the oven.

⚠ WARNING Do not leave children alone. Children should not be left alone or unattended in the area where appliance is in use. They should never be allowed to sit or stand on any part of the appliance, including the storage drawer, lower broiler drawer, warmer drawer, or lower double oven.

⚠ WARNING When heating fat or grease, watch it closely. Grease may catch fire if it becomes too hot.

⚠ WARNING Do not store items of interest to children in the cabinets above a range on the backguard of the ranges. Children climbing on the range to reach items could be seriously injured.

⚠ WARNING Stepping, leaning, or sitting on the door or drawers of an oven can result in serious injuries and also cause damage to the appliance. Do not allow children to climb or play around the oven. The weight of a child on an open over door may cause the oven to tip, resulting in serious burns or other injury.

⚠ WARNING Tip Over Hazard



- A child or adult can tip the range and be killed.
- Verify the anti-tip device has been installed to floor or wall.
- Ensure the anti-tip device is re-engaged to floor or wall when the range is moved.
- Do not operate the range without the anti-tip device in place and engaged.
- Failure to follow these instructions can result in death or serious burns to children and adults.

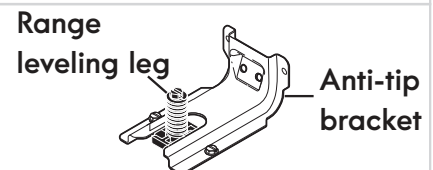

To check if the anti-tip bracket is installed properly, use both arms and grasp the rear edge of the range back. Carefully attempt to tilt range forward. When properly installed, the range should not tilt forward.

Refer to the anti-tip bracket installation instructions supplied with your range for proper installation.

IMPORTANT SAFETY INSTRUCTIONS

Read all instructions before using this appliance.

⚠ WARNING Never cover any slots, holes, or passages in the oven bottom or cover an entire oven rack with materials, such as aluminum foil. Aluminum foil linings may trap heat, causing a fire hazard.

⚠ CAUTION Do not heat unopened food containers. Build-up of pressure may cause container to burst and result in injury.

⚠ CAUTION Do not use water or flour on grease fires. Cover the fire with a pan lid, use baking soda, or use a dry chemical or foam type extinguisher.

⚠ CAUTION Wear proper apparel when cooking. Loose-fitting or hanging garments should never be worn while using this appliance. Do not let clothing or other flammable materials come into contact with hot surfaces.

⚠ CAUTION Use dry potholders. Moist or damp potholders on hot surfaces may result in burns from steam. Do not let potholders touch hot cooking areas. Do not use towels or other bulky cloths.

Important: The California Safe Drinking Water and Toxic Enforcement Act requires the governor of California to publish a list of substances known to cause cancer, birth defects, or other reproductive harms, and it requires businesses to warn customers of potential exposures to such substances.

⚠ CAUTION Do not touch heating elements or interior surfaces of oven. Heating elements may be hot even though they are dark in color. Interior surfaces of ovens become hot enough to cause burns. During and after use, do not touch, or let clothing or other flammable materials contact heating elements or interior surfaces of oven until they have sufficient time to cool. Other surfaces of the appliance may become hot enough cause burns such as the oven door, windows, and the oven vent.

Important: Remove all tape and packaging before using the oven. Destroy the carton and plastic bags after unpacking the oven. Never allow children to play with packaging material.

⚠ WARNING Read and follow all the warnings, cautions and important notes regarding the instructions and precautions for unpacking, installing, and servicing your appliance:

- **Proper Installation**—Be sure your appliance is properly installed and grounded by a qualified technician in accordance with the National Electrical Code ANSI/NFPA No. 70 latest edition and local electrical code requirements. In Canada, install in accordance with CSA Standard C22.1, Canadian Electrical code, Part 1, and local electrical code requirements. Install only per installation instructions provided in the literature package for this oven.
- **User Servicing**—Do not repair or replace any part of the appliance unless specifically recommended in the manuals. All other servicing should be done only by a qualified technician. This reduces the risk of personal injury and damage to the oven.
- Ask your dealer to recommend a qualified technician and an authorized repair service. Know how to disconnect the power to the oven at the circuit breaker or fuse box in case of an emergency.
- Never modify or alter the construction of an oven by removing the leveling legs, panels, wire covers, anti-tip brackets/screws, or any other part of the oven.
- Remove the oven door from any unused oven if it is to be stored or discarded.

IMPORTANT SAFETY INSTRUCTIONS

Read all instructions before using this appliance.

- Do not attempt to operate the oven during a power failure. If the power fails, always turn off the oven. If the oven is not turned off and the power resumes, the oven will begin to operate again. Once the power resumes, reset the clock and oven function.
- Cold temperatures can damage the electronic control. When using this appliance for the first time, or when the appliance has not been used for an extended period of time, be sure the appliance has been in temperatures above 32°F (0°C) for at least 3 hours before turning on the power to the appliance.
- Be sure to have an appropriate foam-type fire extinguisher available, visible, and easily located near the appliance.
- Never leave surface elements unattended. Boil-overs may cause smoking and greasy spills may ignite. A pan that has boiled dry could be damaged and may damage the cooktop.
- Only certain types of glazed cookware, glass, ceramic, earthenware, or other types of glazed utensils are suitable for use on the cooktop. Improper cookware may break due to sudden changes in temperature. Check the cookware manufacturer's recommendations for cooktop use.
- When you are flaming foods under a ventilating hood, turn on the fan.

IMPORTANT INSTRUCTIONS FOR USING YOUR COOKTOP

- Know which knob or key controls each surface heating area. Place cookware with food on the cooking area before turning it on. Turn the cooking area off before removing the cookware.
- Use proper pan size. This appliance is equipped with one or more surface units of different sizes. Select cookware with flat bottoms that match the surface unit heating element. The use of undersized cookware may expose a portion of the heating element to direct contact and may result in the ignition of clothing or other items. Using the proper cookware on the cooking zone will improve efficiency.
- To reduce the risk of burns, ignition of flammable materials, and spills due to unintentional contact with the utensil, the utensil handles should be turned inward and not extend over other cooking areas.

IMPORTANT INSTRUCTIONS FOR CERAMIC GLASS COOKTOPS

- Do not cook on a broken cooktop. If the cooktop is broken, cleaning solutions and spills may penetrate the cooktop and create a risk of electric shock. Contact a qualified technician immediately.
- Clean cooktop with caution. If a wet sponge or cloth is used to wipe spills on a hot cooking area, be careful to avoid steam burns. Some cleaners can produce noxious fumes if applied to a hot surface.

Save these instructions for future reference.

IMPORTANT SAFETY INSTRUCTIONS

Read all instructions before using this appliance.

IMPORTANT INSTRUCTIONS FOR USING YOUR OVEN

- Never use your appliance for warming or heating the room.
- Use care when opening oven door, lower oven door, or warmer drawer (some models). Stand to the side of the oven when opening the door of a hot oven. Let hot air or steam escape before you remove or replace food in the oven.
- Keep oven vent ducts clear. Touching surfaces in this area when the oven is on may cause severe burns. Do not place plastic or heat-sensitive items on or near the oven vent. These items can melt or ignite.
- Always handle oven racks when the oven is cool. Place oven racks in desired positions while the oven is cool. If a rack must be moved while the oven is hot, use extreme caution. Use potholders and grasp the rack with both hands to reposition. Do not let potholders contact the hot heating elements in the oven. Remove all bakeware and utensils before moving the rack.
- Do not use a broiler pan without its insert. Do not cover the broiler insert with aluminum foil; exposed fat and grease could ignite.
- Do not use aluminum foil or other protective liners to line the oven bottom. Only use aluminum foil as recommended in this manual. Improper installation of these liners may result in risk of electric shock or fire.
- Do not cook food on the oven bottom. Always use proper bakeware and use the oven racks.

IMPORTANT INSTRUCTIONS FOR CLEANING YOUR OVEN

⚠ CAUTION Before manually cleaning any part of the oven, be sure all controls are turned off and the oven is cool. Cleaning a hot oven can cause burns.

- Clean the oven regularly to keep all parts free of grease that could catch fire. Do not allow grease to accumulate. Always follow the manufacturer's recommended directions for use of kitchen cleaners and aerosols. Be aware that excess residue from cleaners and aerosols may ignite causing damage and injury.
- Clean ventilating hoods frequently. Grease should not be allowed to accumulate on the hood or filter. Follow the manufacturer's instructions for cleaning hoods.

SELF CLEANING OVENS

- Use the self clean cycle to clean only the parts listed in this manual. Before using self clean, remove the broiler pan, any food, utensils, and bakeware from the oven. Remove oven racks unless otherwise instructed.
- Do not use oven cleaners. No commercial oven cleaner, oven liner, or protective coating of any kind should be used in or around any part of the oven.
- Do not clean the oven door gasket. The door gasket is essential for a good seal. Do not rub, damage, or move the gasket.
- Some birds are extremely sensitive to the fumes given off during the self clean cycle of any oven. Move birds to another well-ventilated room.

Save these instructions for future reference.

IMPORTANT SAFETY INSTRUCTIONS

Read all instructions before using this appliance.

GROUNDING INSTRUCTIONS

⚠ WARNING Avoid fire hazard or electrical shock. Failure to follow this warning may cause serious injury, fire, or death. For personal safety, this appliance must be properly grounded. For maximum safety, the power cord must be plugged into an electrical outlet that is the correct voltage, is correctly polarized and properly grounded in accordance with local codes. Is the personal responsibility of the consumer to have the appropriate outlet with the correct, properly grounded wall receptacle installed by a qualified electrician. It is the responsibility and obligation of the consumer to contact a qualified installer to assure that the electrical installation is adequate and is in conformance with all local codes and ordinances.

See the installation instructions packaged with this appliance for complete installation and grounding instructions.

Serial Plate Location

You will find the model and serial number printed on the serial plate. The serial plate is located as shown.



Figure 1: Location of serial plate

Product Record

In this space below, record the date of purchase, model and serial number of your product. You will find the model and serial number printed on the serial plate.

ModelNo. _____

SerialNo. _____

Date of purchase _____

Save these instructions for future reference.

Before Setting Surface Controls

Using Proper Cookware

The size and type of cookware used will influence the radiant element power level setting needed for best cooking results.

Be sure to follow the recommendations for using proper cookware shown on this page.



Figure 2: Check pan for flat bottom using ruler

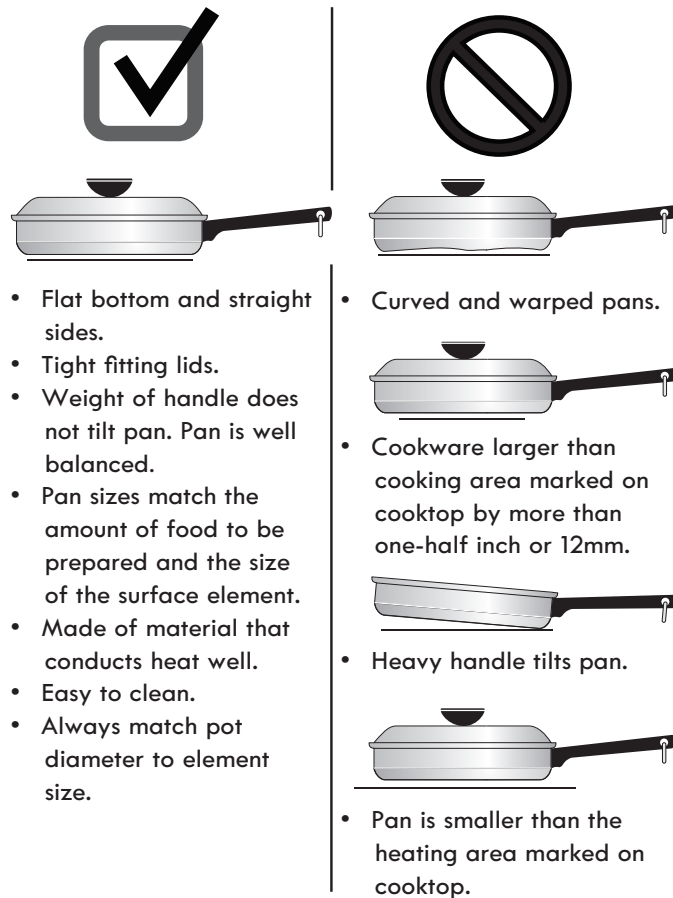

- Flat bottom and straight sides.
- Tight fitting lids.
- Weight of handle does not tilt pan. Pan is well balanced.
- Pan sizes match the amount of food to be prepared and the size of the surface element.
- Made of material that conducts heat well.
- Easy to clean.
- Always match pot diameter to element size.

- Curved and warped pans.
- Cookware larger than cooking area marked on cooktop by more than one-half inch or 12mm.
- Heavy handle tilts pan.
- Pan is smaller than the heating area marked on cooktop.

Cookware Material Types

The cookware material determines how evenly and quickly heat is transferred from the surface element to the pan bottom.

Aluminum - Excellent heat conductor. Some types of food will cause it to darken. (Anodized aluminum cookware resists staining and pitting). If aluminum pans slide across the ceramic cooktop, they may leave metal marks which will resemble scratches. Remove these marks immediately.

Copper - Excellent heat conductor but discolors easily. May leave metal marks on ceramic glass (see Aluminum).

Stainless - Slow heat conductor with uneven cooking results. Is durable, easy to clean and resists staining.

Cast Iron - A slow heat conductor however will retain heat very well. Cooks evenly once cooking temperature is reached. Not recommended for use on ceramic cooktops.

Porcelain-enamel on metal - Heating characteristics will vary depending on base material. Porcelain-enamel coating must be smooth to avoid scratching the ceramic cooktop.

Glass - Slow heat conductor. Not recommended for ceramic cooktop surfaces because it may scratch the glass.

Important note:

Do not place empty aluminum, glass or porcelain-enamel coated cookware on the ceramic cooktop. The melting point of cookware made with these materials may be reached quickly especially if left empty and they may bond to the ceramic cooktop. If the cookware melts it will damage the cooktop. Be sure to follow all the cookware manufacturer's suggestions when using any type of cookware on the ceramic cooktop.

CAUTION Radiant surface elements may appear to have cooled after they have been turned off. The glass surface may still be hot and burns may occur if the glass surface is touched before it has cooled sufficiently.

CAUTION Do not place plastic items such as salt and pepper shakers, spoon holders or plastic wrappings on top of the range when it is in use. These items could melt or ignite. Pot holders, towels or wooden spoons could catch fire if placed too close to the surface elements.

On and Hot Surface Indicator Lights

Your appliance is equipped with indicator lights that will light up when the surface element is turned on. When the surface cooking element heats up the hot surface indicator turns on and remains illuminated until the cooktop has cooled to a moderate level.

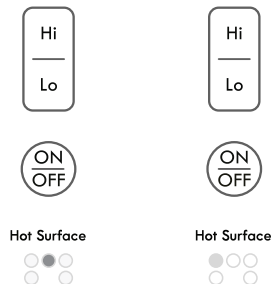

Figure 3: Hot Surface indicators

Important notes:

- Radiant elements have a limiter that allows the radiant heating element to cycle on and off, even at the HI setting. Cycling at the HI setting is normal and will occur more often if the cookware is too small for the radiant element or if the cookware bottom is not flat.
- Be sure to read the detailed instructions for ceramic glass cooktop maintenance and cleaning in the “Care and Cleaning” and “Solutions to Common Problems” sections of this Use and Care Guide.

CAUTION Radiant surface elements may appear to have cooled after they have been turned off. The glass surface may still be hot and burns may occur if the glass surface is touched before it has cooled sufficiently.

CAUTION Do not place plastic items such as salt and pepper shakers, spoon holders or plastic wrappings on top of the range when it is in use. These items could melt or ignite. Potholders, towels or wooden spoons could catch fire if placed too close to the surface elements.

CAUTION Do not allow aluminum foil, empty glass- porcelain cookware or any material that can melt to make contact with the ceramic cooktop. If these items melt on the cooktop they may damage the ceramic cooktop.

CAUTION The areas surrounding the elements may become hot enough to cause burns.

Cooktop Surface Elements

Ceramic Glass Cooktop

The ceramic cooktop has radiant surface elements located below the surface of the glass. The design of the ceramic cooktop outlines the area of the surface element underneath. Make sure the diameter of the pan matches the diameter of the element outline on the cooktop. Heat is transferred up through the surface of the cooktop to the cookware. Only flat-bottom cookware should be used. The type and size of cookware and the number of surface elements in use and their settings are all factors that will affect the amount of heat that will spread to areas beyond the surface elements.

Radiant Surface Elements

The element temperature rises gradually and evenly. As the temperature rises, the element will glow red. To maintain the selected setting, the element will cycle on and off. The heating element retains enough heat to provide a uniform and consistent heat during the off cycle. For efficient cooking, turn off the element several minutes before cooking is complete. This will allow residual heat to complete the cooking process.

Home Canning

Be sure to read and observe all the following points when home canning with your appliance. Check with the United States Department of Agriculture (USDA) website and be sure to read all the information they have available as well as follow their recommendations for home canning procedures.

Tips and procedures for canning foods:



- Use only quality flat bottom canners when home canning. Use a straight-edge to check canner bottom.
- Use only a completely flat bottom canner with no ridges that radiate from the bottom center when home canning using a ceramic cooktop.
- Make sure the diameter of the canner does not exceed 1 inch beyond the surface element markings or burner. It is recommended to use smaller diameter canners on electric coil and ceramic glass cooktops. Start with hot tap water to bring water to boil more quickly.
- Use the highest heat setting when first bringing the water to a boil. Once boiling is achieved, reduce heat to lowest possible setting to maintain that boil.
- Never place or straddle cookware over two different surface cooking areas at the same time. This will cause uneven heating results and may cause the ceramic cooktop to fracture.

Before Setting Surface Controls

Cooktop Lock

The **COOKTOP LOCK** key is used to activate the cooktop lock feature which will lock all surface elements from being accidentally turned on. This feature will only lock the cooktop.

To turn the cooktop lock feature on:

1. Be sure all surface element controls are set to the off position.
2. Press and hold  until two  appear in the display. (About 3 seconds)

If a triple beep sounds instead, check all surface elements and turn them to the off position and repeat this step. The two  appear in the display indicating the cooktop controls and functions are locked out until the cooktop is unlocked.

Whenever the cooktop lock feature is active,  will appear in all of the surface element display windows.

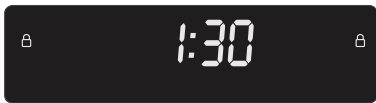



Figure 4: Cooktop locked and showing the lock icons

To turn the cooktop lock feature off:

1. Press and hold the  until two  disappear from the display. (About 3 seconds)
2. The cooktop may now be used again for cooking.

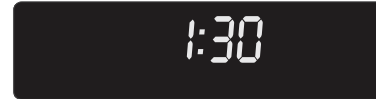

Figure 5: Display showing cooktop available for use

Important: Starting a self clean cycle will automatically turn on the cooktop lock feature. The cooktop will remain locked until the self clean cycle has completed and the oven door has unlocked. If a power failure occurs after the cooktop lock has been activated, you must turn off the cooktop lock feature before being able to use the cooktop features again.

Locations of the Radiant Surface Elements and Controls

Your range is equipped with radiant surface burners with different wattage ratings. The ability to heat food quicker and in larger volumes increases as the element wattage increases. The radiant surface elements are located on the cooktop as follows:

- One 7 inch radiant elements located at the left rear.
- One 6 - 9 - 12 inch expandable triple element located at the right front position.
- One 9 inch turbo boil radiant element located at the left front position.
- One WARM ZONE located at the center rear position.
- One 6 inch Simmer Flex element located at the right rear of the cooktop. The Simmer Flex allows very low controlled simmering for sauces and melting and to maintain a low cooking heat for many items.

Setting Surface Controls

The Electronic Surface Element Control (ESEC)

The Electronic Surface Element Control (ESEC) feature provides a digital display of the radiant surface elements on the cooktop. The ESEC display in combination with the keys is designed to replace conventional control knobs.

Cooktop Display Windows

The cooktop controls provide a digital display for each of the radiant surface elements located on the cooktop. Power levels and messages are easily monitored and adjusted using the corresponding control key in combination with the window displays.

The cooktop control will display heat levels ranging from **Hi** to **Lo** and **off** (Figure 6). The settings between **9.5** and **3.0** (Figure 7) decrease or increase in increments of .5 (1/2). The settings between **2.8** and **1.2** (Figure 8) are Simmer settings which decrease or increase in increments of .2 (1/5) to **Lo** for more precise settings at lower heat levels.



Figure 6: Range from Hi setting to Lo to OFF (blank display)



Figure 7: Settings between 9.5 and 3.0



Figure 8: Settings between 2.8 and 1.2

The **Hot Surface** indicator will appear in the display (Figure 9) when any surface cooking element heats up and will remain on until the cooktop has cooled to a moderate level. If the hot surface indicator appears in the display, the control can still be turned on again for use.



Figure 9: Hot surface indicator

CAUTION Radiant surface elements may appear to have cooled after they have been turned off. The glass surface may still be hot and burns may occur if the glass surface is touched before it has cooled sufficiently.

CAUTION Do not place plastic items such as salt and pepper shakers, spoon holders or plastic wrappings on top of the range when it is in use. These items could melt or ignite. Potholders, towels or wooden spoons could catch fire if placed too close to the surface elements.

CAUTION Do not allow aluminum foil, empty glass-porcelain cookware or any material that can melt to make contact with the ceramic cooktop. If these items melt on the cooktop they may damage the ceramic cooktop.

- Radiant elements have a limiter that allows the radiant heating element to cycle on and off, even at the HI setting. Cycling at the HI setting is normal and will occur more often if the cookware is too small for the radiant element or if the cookware bottom is not flat.
- Be sure to read the detailed instructions for ceramic glass cooktop maintenance and cleaning in the “Care and Cleaning” and “Solutions to Common Problems” sections of this Use and Care Guide.

Cooktop Surface Elements

The ceramic glass cooktop has radiant surface elements located below the surface of the glass. The patterns on the ceramic glass will outline the size and type of element available.

The single radiant element or elements will have one round outline pattern shown on the cooktop. The warm zone located on the center rear area of the cooktop uses one round outline and is designed only to keep food warm.

A dual or triple (on some models) radiant element allows the user to set the smaller inner portion as a single element or both inner and outer portions may be set to heat together.

A simmer flex element (some models) allows for very low precision simmering and also normal cooking.

Setting Surface Controls

Suggested Element Settings

The suggested settings below are based on averages when cooking with medium-weight aluminum pans with lids. Settings may vary when using other types of pans.

Table 1: Suggested settings for various cooking needs

Settings	Type of Cooking
High (8.0-HI)	Start most foods, bring water to boil, pan broiling
Medium-high (5.0-8.0)	Continue a rapid boil, fry, deep fat fry
Medium (3.0-5.0)	Maintain a slow boil, thicken sauces and gravies, steam vegetables
Medium-low (2.0-4.0)	Keep foods cooking, poach, stew
Low (LO-2.0)	Keep warm, melt, simmer

Important notes:

- For efficient cooking, turn off the element several minutes before cooking is complete. This will allow residual heat to complete the cooking process.
- Each surface element provides a constant amount of heat at each setting.
- Refer to the suggested radiant surface element settings for suggested power level settings. A glowing red surface heating area extending beyond the bottom edge of the cookware indicates the cookware is too small for the surface heating area.

Single Radiant Surface Elements (all models)

CAUTION Radiant surface elements may appear to have cooled after they have been turned off. The glass surface may still be hot and burns may occur if the glass surface is touched before it has cooled sufficiently. Do not place plastic items such as salt and pepper shakers, spoon holders or plastic wrappings on top of the range when it is in use. These items could melt or ignite. Pot holders, towels or wooden spoons could catch fire if placed too close to the surface elements.

CAUTION Do not allow aluminum foil, empty glass or porcelain cookware or any material that can melt to make contact with the ceramic cooktop. If these items melt on the cooktop they may damage the ceramic cooktop.

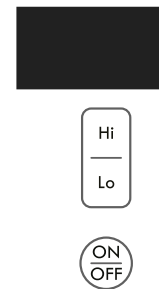

Figure 10: Single element located on left rear of cooktop

To operate the single radiant element:

1. Place correctly sized cookware on single radiant surface element.
2. Push the **ON OFF** key to turn on.
3. Press **HI** to start the burner. To lower the setting press **Lo** until the desired level appears in the display.
4. When cooking is complete, turn the radiant surface element off using the **ON OFF** key before removing the cookware.

Single, Double or Triple Radiant Surface Element

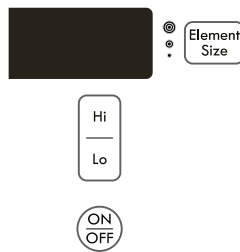

Figure 11: Multiple size radiant element control



Figure 12: 6, 9, or 12 inch expandable element

To operate the expandable radiant element:

1. Place cookware on the radiant surface element.
2. Press **ON OFF** key.
3. Press **Hi** or **Lo** and set burner to desired level of heating.
4. Press the **Element Size** key to select the proper size for the cookware.

Note: If necessary, the element size can be adjusted during the cooking process by pressing the **Element Size** key until the desired setting is reached.

5. When cooking is complete, turn the radiant surface element off before removing the cookware.

Note: The power level settings for the **Simmer Flex** element use lower heat increments. See "[Simmer Flex Element](#)" on this page for instructions.

CAUTION Do not place flammable items such as plastic salt and pepper shakers, spoon holders or plastic wrappings on top of the range when it is in use. These items could melt or ignite. Pot holders, towels or wooden spoons could catch fire if placed too close to the surface elements.

CAUTION Do not allow aluminum foil, empty glass-porcelain cookware or any material that can melt to make contact with the ceramic cooktop.

Using Turbo Boil™ Flex

The Turbo Boil™ (Flex) feature uses a higher wattage radiant element to bring liquids to boil much quicker. The left front radiant element is the TURBO BOIL FLEX burner. To use the Turbo Boil™ Flex feature, place the cookware on the left front surface element and follow the instructions for "[Single Radiant Surface Elements \(all models\)](#)" in this section.

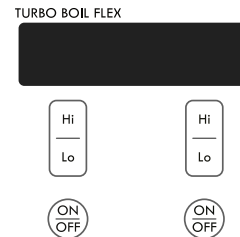

Figure 13: Turbo Boil Flex element control

Simmer Flex Element

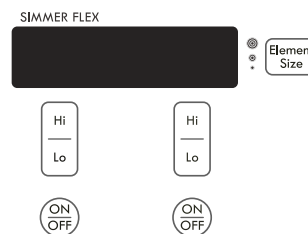

Figure 14: Simmer flex located on right rear of cooktop

The simmer flex element allows for lower simmer settings than a standard element. These lower increments provide very low heat for precision simmering. The element settings range from **LO** to **2.0** in increments of .2 (2/10ths) for a total of ten simmer settings.

The simmer flex also has a wider range of temperature settings above 2.0. The range between **2.0** and **Hi** is shown in the display as follows: 2.0, 2.5, 3.0, 4.0, 5.0, 6.0, 7.0, 8.0, 9.0, and HI.

To set the simmer flex element:

1. Press the **ON OFF** key to activate the element.
2. If using the simmer flex for normal cooking start on **HI** and press **LO** until the desired setting is shown in the display.
3. When ready to simmer cooked foods, press **LO** until the desired simmer level appears in the display.
4. When cooking is complete, turn the simmer flex element off before removing the cookware.

Setting Surface Controls

WARM ZONE

The purpose of the warm zone is to keep hot cooked foods at serving temperature. Use the **WARM ZONE** feature to keep cooked foods hot such as vegetables, gravies, casseroles, soups, stews, breads, pastries and oven safe dinner plates.

Always start with hot food. Do not heat cold food with the warm zone. All food placed on the warm zone should be covered with a lid to maintain quality. When warming pastries or breads, the cover should have an opening to allow moisture to escape. Use only dishware, utensils and cookware recommended for oven and cooktop on the warm zone.

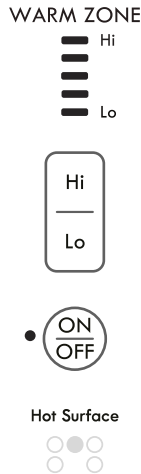

⚠ CAUTION Unlike other radiant surface elements, the warm zone will not glow red when it is hot. The glass surface may still be hot and burns can occur if the glass surface is touched before it has cooled sufficiently.

⚠ CAUTION Do not place flammable items such as plastic salt and pepper shakers, spoon holders or plastic wrappings on top of the range when it is in use. These items could melt or ignite. Pot holders, towels or wooden spoons could catch fire if placed too close to the surface elements.

⚠ WARNING Food poisoning hazard. Do not let food sit for more than one hour before or after cooking. Doing so can result in food poisoning or sickness.

To operate the WARM ZONE:

1. Press the **ON OFF** key and then press **HI** or **Lo** to start the warm zone heating. To raise or lower the temperature use the **HI** or **Lo** key to set the desired heat level.
2. When ready to serve, press the **ON OFF** key to turn off. The warm zone will remain hot until the hot surface indicator light turns off.

Refer to the **WARM ZONE** recommended food settings table. If a particular food is not listed, start with the medium level, and adjust as needed.

Table 2: Recommended settings for WARM ZONE

Food Item	Heating level
Breads and Pastries	LO (Low)
Casseroles	LO (Low)
Dinner Plates with food	LO (Low)
Meats	MED (Medium)
Sauces	MED (Medium)
Vegetables	MED (Medium)
Fried foods	HI (High)
Hot beverages	HI (High)
Soups (clear)	HI (High)

Electronic Surface Element Controls in the Sabbath mode

When the Sabbath feature is active, the cooktop burners will not be available unless they are already active before entering the Sabbath mode. Once in Sabbath it is not possible to turn a burner on from the **OFF** position. It is possible to adjust the settings of an active burner.

To adjust a surface burner when the oven Sabbath feature is active:

1. Press the **HI** or **LO** key for the desired element. The heat setting will not appear in the display because **Sb** is showing. Any adjustment to the heat setting will take 15 to 30 seconds to go into effect.

To turn off a surface element while the oven Sabbath mode is active:

1. Press the **ON OFF** key for that element. The element will immediately turn off without delay.

Sabbath Feature (**Sb**) Message

The cooktop display windows will show the **Sb** message whenever the Sabbath feature is active (Figure 15).



Figure 15: Display indicating oven is set for Sabbath

Before Setting Oven Controls

Oven Vent Location

The oven vent is located under the left side of the control panel (Figure 16). Do not block oven vent. When the oven is on, warm air passes through this vent. This venting is necessary for proper air circulation in the oven and good baking results. It is normal for steam or moisture to appear near the oven vent. Some models are equipped with a cooling fan that runs during the cooking process to cool internal electronic components. It is normal for this fan to continue to run for an extended period of time, even when the oven is off.

Upper and lower Oven Vent



Figure 16: Oven vent location

⚠ CAUTION Always use pot holders or oven mitts when using the oven. When cooking, the oven interior and exterior, oven racks and cooktop will become very hot which can cause burns. Do not use aluminum foil to line the oven bottom. Only use aluminum foil as recommended in this manual. Improper installation of these liners may result in risk of electric shock, or fire.

Removing, replacing, and arranging flat or offset oven racks:

To arrange - Always arrange the oven racks when the oven is cool (prior to operating the oven).

To remove - Pull the oven rack straight forward until it reaches the stop position. Lift up front of oven rack slightly and slide out.

To replace - Place the oven rack on the rack guides on both sides of oven walls. Tilt the front of oven rack upward slightly and slide the oven rack back into place. Be sure oven racks are level before using the oven.

Types of Oven Racks

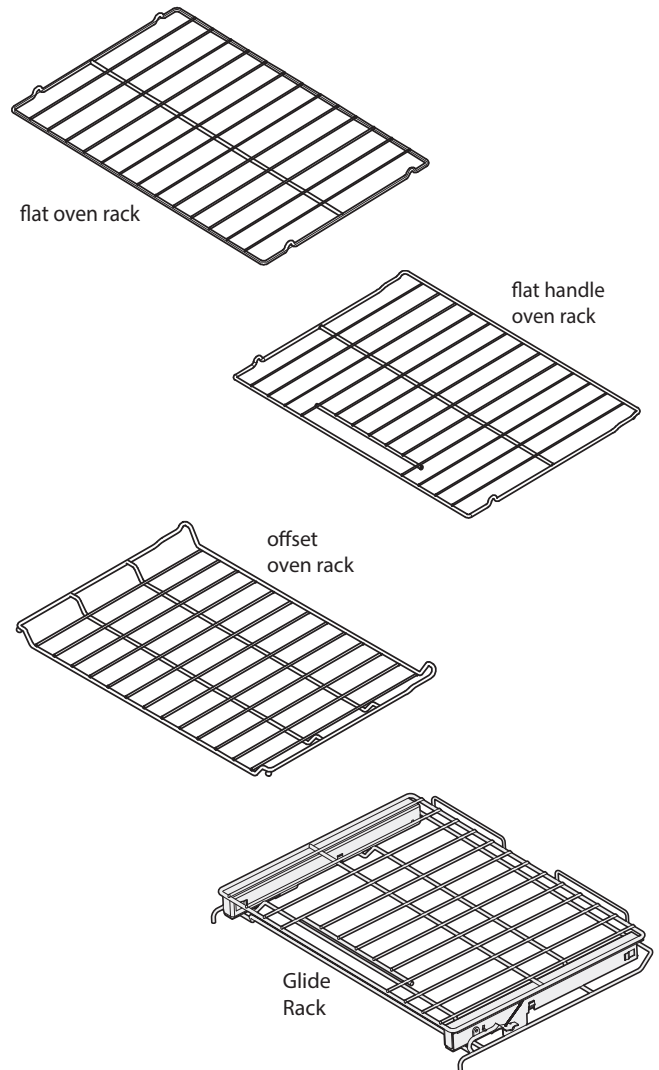

The flat oven rack (some models) or flat handle oven rack (some models) may be used for most cooking needs.

The offset oven rack (on some models) is designed to place the base of the rack about 1/2 of a rack position lower than flat oven racks. This design allows several additional positions between the flat rack positions.

To maximize oven cooking space place the bottom oven rack (on some models) in the lowest rack position for roasting large cuts of meat.

Before Setting Oven Controls

The Glide Rack

The glide rack is an extendable rack that makes food preparation easier. It has glide tracks that allow the rack to be pulled away from the oven without rubbing the sides of the oven wall.

Removing and replacing the glide racks

To remove the glide rack:

1. Lift up on the release lever located across the lower front of the rack, as shown in [Figure 17](#).
2. While holding up the release lever ([Figure 18](#)), pull the glide rack out of the oven until the stop position is reached, use two hands if necessary.
3. Using both hands, grasp the upper and lower portions of the glide rack ([Figure 19](#)).
4. Lift up the front of the rack slightly and continue to pull the rack away from the oven.
5. Be sure to grasp both upper and lower rack portions together when removing or handling the glide rack. The rack portions move independently and are difficult to handle unless held together..

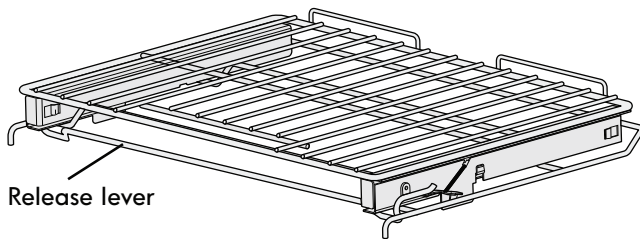

Figure 17: Extendable glide rack with release lever in locked position

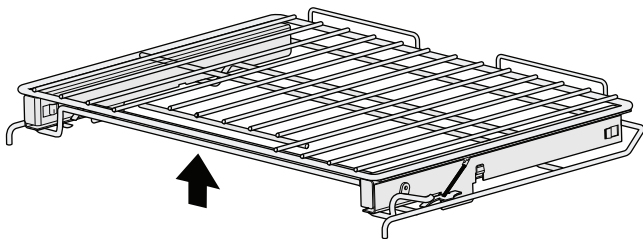

Figure 18: Glide rack with release rack in unlocked position

To replace the glide rack:

1. Grasp both upper and lower portions of the glide rack ([Figure 19](#)).
2. Lift and hold the rack level between the oven cavity walls.
3. Tilt the front of the rack upward slightly and slide the rack completely into position. Some force may be necessary to make sure the oven rack has snapped into place.

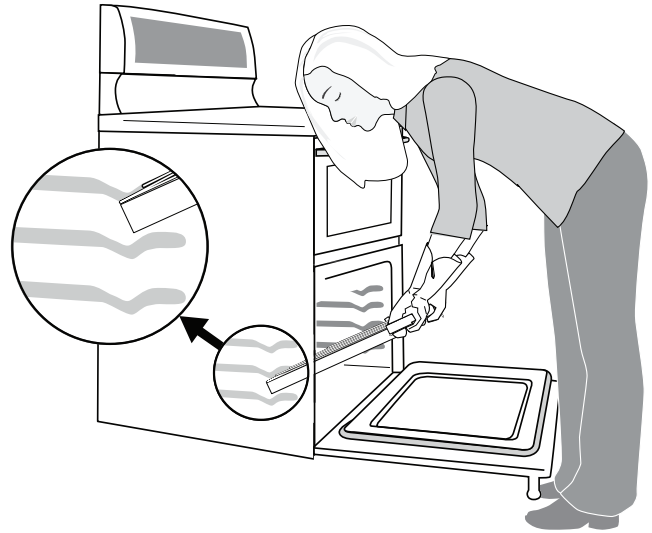
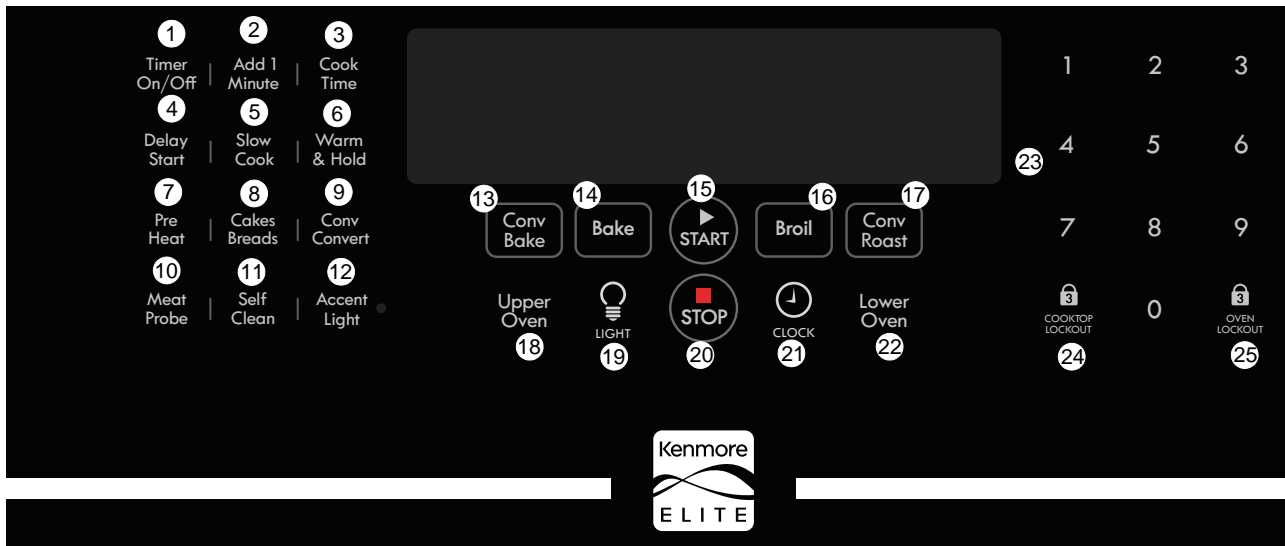

Figure 19: Removing and replacing glide rack from oven

Air Circulation in the Oven

For best baking results allow 2-4" (5-10 cm) around the cookware for proper air circulation and be sure pans and cookware do not touch each other, the oven door, sides or back of the oven cavity. Hot air must be able to circulate around the cookware in the oven for even heat to reach around the food.

Setting Oven Controls



1. **Timer ON/OFF** - Used to set or cancel timer.
2. **Add 1 Minute** - Used to add additional minutes to timer.
3. **Cook Time** - Used to enter the length of the cook time desired.
4. **Delay Start** - Used to set the desired start time for baking. May be used with cook time to program a delayed bake or delayed clean cycle.
5. **Slow Cook** - Used to set the slow cook feature.
6. **Warm & Hold** - Used to set the Warm & Hold feature.
7. **Preheat** - Used to preheat the oven.
8. **Cakes and Breads** - Use when baking cakes or bread.
9. **Conv Convert** - Used to select the convection convert feature.
10. **Meat Probe** - Used to set probe for internal temperature of food.
11. **Self Clean** - Used to set a 2 to 4 hours self clean cycle.
12. **Accent Light** - Used to turn accent light on and off.
13. **Conv Bake** - Used to select the convection bake feature.
14. **Bake** - Used to enter the normal bake feature.
15. **START** - Used to start all oven features (except oven light).
16. **Broil** - Used to select variable broil feature.
17. **Conv Roast** - Used to select the convection roast mode.
18. **Upper Oven** - Used to select the upper oven.
19. **(Oven) LIGHT** - Used to turn oven light on and off.
20. **STOP** - Used to cancel all functions except clock and timer.

21. **CLOCK** - Used to set the time of day.
22. **Lower Oven** - Used to select the lower oven.
23. **0 thru 9 number** - Used to enter temperatures and time.
24. **COOKTOP LOCK** - Used to lock the cooktop keys and surface elements.
25. **OVEN LOCK** - Used to lock the oven keys and oven door.

Minimum and Maximum Control Settings

All of the features listed below have minimum and maximum time or temperature settings. An entry acceptance beep will sound each time a control key is touched (the oven lock is delayed 3 seconds). An entry error tone (three short beeps) will sound if the entry of the temperature or time is below the minimum or above the maximum settings for the feature.

Feature	Min temp. or time	Max temp. or time
PreHeat	170°F (77°C)	550°F (288°C)
Bake	170°F (77°C)	550°F (288°C)
Broil	400°F (205°C)	550°F (288°C)
Timer	1 Min.	11:59 Hr./Min.
Self Clean	2 hours	4 hours
Conv Bake	170°F (77°C)	550°F (288°C)
Conv Roast	170°F (77°C)	550°F (288°C)
Slow Cook	Lo 225°F (107°C)	Hi 225°F (135°C)
Cakes and Breads	170°F (77°C)	550°F (288°C)
Warm & Hold	170°F (77°C)	3 hours
Meat Probe	140°F (60°C)	210°F (99°C)
Cook Time	1 Min.	11:59 Hr./Min.
Delay Time 12 Hr.	1 Min.	11:59 Hr./Min.
Delay Time 24 Hr.	1 Min.	23:59 Hr./Min.



Setting Oven Controls

Setting the Clock

The  key is used to set the clock. The clock may be set for 12 or 24 hour time of day operation. The clock has been preset at the factory for the 12 hour operation. When the range is plugged in, or when the power supply to the range has been interrupted, the time in the display will flash.

Press . The display will stop flashing.

Example: Setting the clock for 1:30:

1. Press . **CLO** will appear in the display.
2. Press **1 3 0** using the numeric keypad to set time of day.
3. Press .
4. Time of day will now appear in the display.



Setting Minute Timer

The **Timer ON/OFF** controls the timer that can be used during any of the other oven control functions, except self clean and Sabbath. It does not start or stop any cooking function.

To set Timer for 5 minutes:

1. Press **Timer ON/OFF**. When dashes appear in the display press the number **5** key and press . The time will begin to count down.



Figure 20: Setting timer for 5 minutes

2. When timer runs out, **End** and **TIMER** show in display. The clock will beep three times every 7 seconds until **Timer ON/OFF** is pressed. Press **Timer ON/OFF** to cancel the timer at any time.



To Set Add 1 Minute

The **Add 1 Minute** key is used to set the Add 1 Minute feature. When the key is pressed, 1 minute is added to the timer if already active. If the timer is not active and **Add 1 Minute** is pressed, the timer will start and will begin counting down from 1 minute. Each press of the key will add 1 minute to the timer.

Changing Between 12 or 24 Hour Time of Day

1. Press and hold  for about 6 seconds until **12 Hr day** or **24 Hr day** appears in the display.
2. Press **Self Clean** to switch between the 12 and 24 hour time of day displays. The display will show either 12 Hr or 24 Hr.



3. Press  to accept the change or press  to reject.
4. Reset the correct time as prescribed in "Setting the Clock".

Note: if the 24 hour time of day was selected, the clock will now display time from 0:00 through 23:59 hours.

Setting Continuous Bake or 12 Hour Energy Saving

The **Timer ON/OFF** and **Self Clean** keys control the continuous bake or 12 hour energy saving features. The oven control has a factory preset 12 hour energy saving feature that turns off the oven if left on for more than 11 hours and 59 minutes. The oven can be programmed to override this for continuous baking.

To set the Continuous Bake or 12 Hour Energy feature:

1. Press and hold **Timer ON/OFF** for about 6 seconds. The display will show either **12 Hr OFF** or **Stay On** and the control will beep once.



Figure 21: Display shows energy saving or continuous cooking

2. Press **Self Clean** to switch between the 12 hour energy saving and continuous bake features.

Note: **12 Hr OFF** indicates the control is set for the 12 hour energy saving mode. **Stay On** indicates the control is set for the continuous baking.

3. Press  to accept your selection and the display will return to show the time of day.

Setting the Oven Lock

The  controls the oven lock feature. The oven lock automatically locks the oven door and prevents the oven from being turned on. It does not disable the cooktop, clock, timer or the interior oven light. The ovens can be locked individually.

To activate the oven lock feature:

1. Press **Upper** or **Lower Oven**.
2. Press and hold  for 3 seconds.
3. After 3 seconds, **DOOR, LOCKED** will flash and **Loc** will appear in the display.

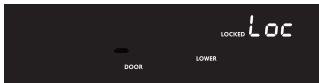

Once the oven door is locked the **DOOR** and **LOCKED** indicator will stop flashing and remain in the display. Allow 15 seconds for the oven door to lock completely.

To reactivate normal oven operation by unlocking door:

1. Press **Upper** or **Lower Oven**.
2. Press and hold  for 3 seconds. **Loc** will disappear from the display. **DOOR** and **LOCKED** will flash in the display until the door has completely unlocked and the oven will be operational. The oven lock can be set for one oven or both. An unlocked oven may be used if the other is locked.

Operating Oven Light

The interior oven light will automatically turn on when the oven door is opened. Press  to turn the interior oven light on and off whenever the oven door is closed.

Important note: The oven light will not operate during self clean.

The interior oven light is located on the left wall of the oven interior and covered with a glass shield to protect the bulb from high temperatures. The shield should always be in place whenever the oven is in use. To replace the interior oven light, see **Replacing oven lights** in the **Care and Cleaning** section.

Setting Temperature Display -- Fahrenheit or Celsius



The **Broil** and **Self Clean** keys control the Fahrenheit or Celsius temperature display modes. The oven can be programmed to display temperatures in Fahrenheit or Celsius. The oven has been preset at the factory to display in Fahrenheit. Both ovens will be changed at the same time.

To change display from Celsius to Fahrenheit or Fahrenheit to Celsius:

1. Press and hold the **Broil** key for about 6 seconds until it beeps: **F** or **C** appears in the display. The **F** means the oven is set for Fahrenheit and **C** means the oven is set for Celsius.



Figure 22: The display will show the temperature setting for Fahrenheit or Celsius

2. Press **Self Clean** to toggle between Fahrenheit or Celsius modes.
3. Press  to accept the change or press  to reject the change.

Setting Silent Control Operation



The **Self Clean** and **Delay Start** keys are used to set the silent control operation which allows the oven to be operated without sounds whenever necessary. The control can be returned to operating with all the normal sounds and beeps.

To change from normal sound to silent operation:

1. Press and hold **Delay Start** for 6 seconds. The display will show dashes and then change to **bEEP On** in the display.



Figure 23: Audible operation (L) Silent operation (R)

2. Press **Self Clean** to switch between normal sound operation and silent mode.
3. Press  to accept the change or press  to reject the change.

Note: In silent operation the control will still beep at the end of a timer and when a set temperature has been reached.

Setting Oven Controls

Setting Preheat

The **Pre Heat** key controls the preheat feature. Preheating will bring the oven up to temperature and then alert when to place the food in the oven.

Important: For batter and dough-based baked goods such as cakes, pastries, and breads, use the standard bake and convection bake functions for best results.

Preheating is not necessary when roasting or cooking casseroles. The oven can be programmed to preheat at any temperature between 170°F to 550°F (77°C to 288°C).

To set the preheat temperature to 350°(177°C):

1. Arrange the interior oven racks to the proper settings.
2. Press **Upper** or **Lower Oven**.
3. Press **Pre Heat**. The default oven temperature of **350** will appear in the display.
4. Press . **BAKE** will appear in the display. **PRE** and the actual oven temperature shown in the display will alternate as the oven heats and reaches 350°.

Note: The oven icon appears in the display showing the bake, broil, and convection elements cycling. The convection fan will turn on to help the oven reach the desired temperature faster.



Figure 24: Set temperature shown (top). Minimum temperature appears when oven is started (below)

When starting with a cold oven, the temperature display will show 100 until the oven has warmed to a temperature above 100 degrees. After that, the actual oven temperature will show in the display while alternating with **PRE**.

After the oven has reached the set temperature (350°F), the control will beep indicating the time to place food in the oven. The convection fan will turn off and the display will show **350°**. The oven will continue to operate in the bake mode.

Press  when baking is complete or to cancel the preheat feature.

To change preheat temperature (from 350°F to 425°F) while oven is preheating:

1. While oven is preheating, press **Pre Heat** again. .



2. Enter the new temperature. Press **425**.



3. Press . **PRE** will appear in the display until the new set temperature of 425°F is reached. At that time a long beep will sound once indicating that the oven has reached the new set temperature of 425°F.



4. When baking is complete press .

Note: While in preheat mode, the convection fan will be active to allow the oven to reach its target temperature faster.

Setting Bake

Use the bake feature whenever the recipe calls for baking using normal temperatures. A reminder tone will sound indicating when the set bake temperature is reached and to place the food in the oven. During preheat the convection fan will run to help heat the oven to the set temperature. The fan will turn off when the set temperature is reached. The baking elements inside the oven will cycle on and off during the baking process.

Bake may be set for any oven temperature between 170°F (77°C) to 550°F (288°C).

To set bake for oven temperature of 425°F (218°C):

1. Select **UPPER** or **LOWER** oven.
2. Press **Bake**. Enter **4 2 5** using the numeric keypad.
3. Press **Start**.

To cancel bake at any time press .

For best results:

- Fully preheat the oven before baking items like cookies, biscuits and breads and use convection bake.
- During bake the oven elements and fan will cycle on and off for best cooking performance.
- Dark or dull pans absorb more heat than shiny bakeware, resulting in dark or overbrowning of foods. It may be necessary to reduce the oven temperature or cook time to prevent overbrowning of some foods. Dark pans are recommended for pies. Shiny pans are recommended for cakes, cookies and muffins.
- Do not open oven door often. Opening the door will reduce the temperature in the oven and may increase cook time.

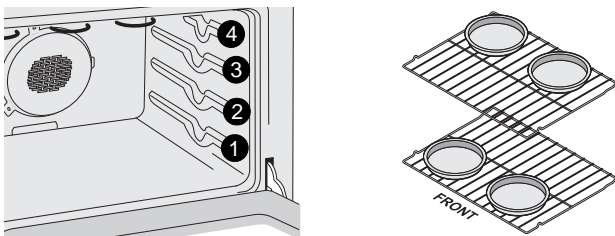

Figure 25: Rack positions and pan spacing recommendations

Radiant rack positions:

- When using any single rack, position the rack so that the food is in the center of the oven.
- For best results when baking cakes using two flat oven racks, place racks in positions 1 and 3 as shown in [Figure 25](#). For the Glide rack, set one position lower (position 2) and use offset rack in position 1. Allow at least 2 inches (5 cm) of space between bakeware for proper air circulation.

Setting Cook Time

The **Cook Time** key controls the cook time feature. The automatic timer of the feature will turn the oven off after cooking for the amount of time selected. Cook time can be set with bake, convection bake, convection roast, and slow cook. When combined with the delay start feature a cooking function can be set to start at a later time. Cook time can not be combined with broil or self clean.

To program the oven to begin baking at 350°F immediately for 30 minutes and to shut off automatically:

1. Be sure the clock is set for the correct time of day
2. Press **UPPER** or **LOWER** oven.
3. Press **Bake**.



Figure 26: Display showing default temperature of 350

4. Press .
5. Press **Cook Time**. The display will show -- --.



6. Enter desired bake time by pressing **30**.



7. Press .

The display will show both the time of day and the oven temperature will appear above the oven icon. Once the set temperature is reached it will remain in the display along with the time of day. While baking, press the **Cook Time** key to display the time remaining in the timed bake mode.

When the bake time finishes, **END** and the time of day will show in the display and the oven turns off automatically. The control will beep three times and continue to beep every 30 seconds until  is pressed.

Setting Oven Controls

Setting Delay Start

The **Delay Start** key controls the delay start feature. The automatic timer of the delay start will turn the oven on at the time you select in advance. Adding a cook time to the delay start time will allow the oven to turn off automatically.

Note: If the clock is set for normal 12 hour display mode the delayed time bake or delayed timed convection bake cycle can not be set to start more than 12 hours in advance.

⚠ WARNING Food poisoning hazard. Do not let food sit for more than one hour before or after cooking. Doing so can result in food poisoning or sickness. Foods that can easily spoil such as milk, eggs, fish, meat or poultry, should be chilled in the refrigerator first.

To program the oven for a delayed bake start time at 5:30, bake for 30 minutes and to shut off automatically:

Be sure that the clock is set with the correct time of day. Arrange oven rack(s) and place the food in the oven.

1. Press **UPPER** of **LOWER** Oven.
2. Press **Bake**. The default temperature (**350°F**) appears in the display.



3. Press **Delay Start**. The display will show -- --.
4. Enter the desired start time using the numeric keypad **5 3 0**.

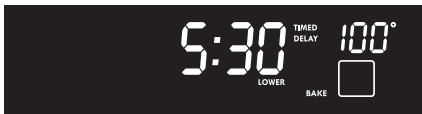

5. Press **Cook Time**. Enter **30** using numeric keys.



6. Press **START**. The minimum oven temperature appears. The minimum oven temperature appears in the display. The current time of day will appear in the display.



7. Press **START**. The oven will stop heating will remain in this state until the set start time is reached.



Figure 27: Display shows the oven set for delayed start

8. When the delayed start time is reached, the oven icon will appear in the display and the oven will start to bake at the previously selected temperature.
9. Press **STOP** when baking is finished or at any time to cancel.

When the bake time runs out:

10. **END** will appear in the display and the oven will turn off automatically.



11. The control will beep three times. The control will continue to beep three times every 30 seconds until **STOP** is pressed.

Setting Convection Bake

Use the convection bake feature when cooking speed is desired. The oven can be programmed for convection baking at any temperature between 170°F (77°C) to 550°F (288°C).

Convection baking uses a fan to circulate the oven's heat evenly. (Figure 28). This improved heat distribution allows for fast, even cooking and browning results. Breads and pastries brown more evenly. Convection bake cooks most foods faster and more evenly than conventional baking.

For best results:

- When using convection bake, decrease your normal cooking times. Adjust the cook time for desired doneness as needed. Time reductions will vary depending on the amount and type of food to be cooked. Cookies and biscuits should be baked on pans with no sides or very low sides to allow heated air to circulate around the food. Food baked on pans with a dark finish will cook faster.

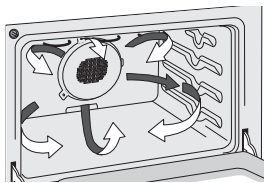

Figure 28: Air circulation during convection cooking

- Preheating is not necessary when cooking casseroles with convection bake. When using a single rack, place the rack in center of oven. If cooking on multiple racks, place the flat oven racks in positions 1 and 3. When using Glide rack set one position lower (position 2) and use offset rack in position 1.
- Do not open oven door often. Opening the door will reduce the temperature in the oven and may increase cook time.

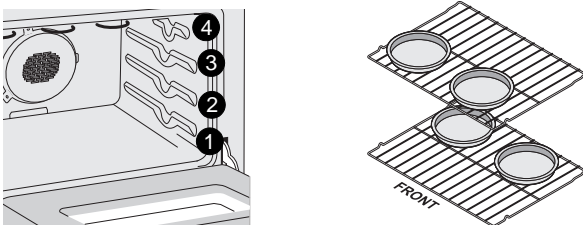

Figure 29: Rack positions and pan spacing recommendations

To set the oven for convection bake and temperature to 350°F

1. Arrange interior oven racks and place food in oven.
2. Press **Upper** or **Lower Oven**.
3. Press **Conv Bake**. The default temperature of **350°F** appears in the display.
4. Press **START**. The minimum oven temperature will be displayed.
5. A beep will sound once the oven temperature reaches 350°F.

Press **STOP** to cancel convection bake at any time.

- Do not open the oven door too often. Opening the door will reduce the temperature in the oven.

Setting Convection Convert

The **Conv Convert** key is used to automatically convert a standard baking recipe for convection baking. Convection convert must be used with convection bake set for a bake time of more than 20 minutes. A cook time or delay start function may be added.

Using the convection convert feature (during convection bake) to automatically adjust oven temperature:

1. Arrange interior oven racks and place food in oven.
2. Press **Upper** or **Lower Oven**.
3. Press **Conv Bake**. The oven will start baking at the default temperature of 350°.



4. If a cook time or delay start is desired enter times now.
5. Press **Conv Convert**. The temperature conversion of **325°** will appear briefly in the display. A beep will sound once the adjusted temperature is reached.



Note: When used with a cook time or a delay start setting, the convection convert feature will display a **CF** for check food when the bake time is 75% complete. At this time the oven control will sound three beeps at regular intervals until baking has finished. When the bake time has completely finished the display will show **End** and the control sound three beeps every 30 seconds until **STOP** is pressed.

Note: The minimum amount of cook time using the convection convert feature with a cook time or delay start function is 20 minutes.

Setting Oven Controls

Setting Broil

The **Broil** key controls the broil feature. When broiling, heat radiates downward from the oven broiler for even coverage. The broil temperature may be set between 400°F and 550°F.

The broil pan and broil pan insert used together allow dripping grease to drain and be kept away from the high heat of the oven broiler (Figure 30). Do not use the broil pan without the insert. Do not cover the broil pan insert with foil. The exposed grease could catch fire.

CAUTION The broil burner may appear to have cooled after it has been turned off. The burners may still be hot and burns may occur if these burners are touched before they have cooled sufficiently. Always wear oven mitts when working with the oven.

WARNING Should an oven fire occur, close the oven door and turn off the oven. If the fire continues, throw baking soda on the fire or use a fire extinguisher. Do not put water or flour on the fire. Flour may be explosive and water can cause a grease fire to spread and cause personal injury.

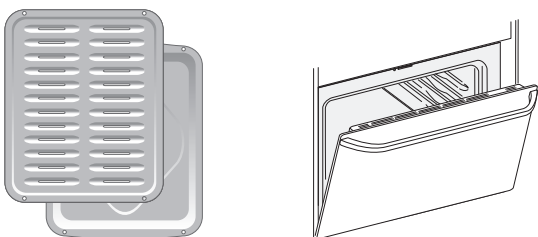



Figure 30: Broil pan and insert (L) Broil Stop position (R)

To set the oven to broil at 550°F.

1. Arrange the interior oven rack.
2. Press **Upper** or **Lower Oven**. Press . The oven will begin the broil function at 550°F (288°C). If a lower broil temperature is desired (minimum broil temperature setting is 400°F), enter the desired temperature with the numeric keys.
3. Preheat the oven for 2 minutes when broiling in the upper oven, and preheat for 5 minutes when using the lower oven. Preheat oven with door closed.
4. Once the oven is preheated, place the broiler pan insert on the broiler pan. Then place the food on the broiler pan insert and place the broiler pan on the rack. Be sure to center the broiler pan directly under the broiler element. Make sure the oven door is open to the broil stop position when broiling (Figure 30)..



5. Broil on one side until food is browned. Turn and cook on the second side. Season and serve.

Note: Always pull the rack out to the stop position before turning or removing food.

6. To cancel broiling press .

Note: If a broiler pan and insert were not supplied with this appliance, they may be purchased from Sears. Order by calling 1-800-4-MY-HOME (1-800-469-4663) and order broiler pan kit 5304442087.

Food Item	Rack Position	Temperature	Cook time		Internal Temperature	Doneness
			1st side	2nd side		
Steak 1" thick	3rd or 4th*	550°F (288°C)	6:00	4:00	145°F (63°C)**	Medium-Rare
	3rd or 4th*	550°F (288°C)	7:00	5:00	160°F (71°C)	Medium
Pork Chops 3/4 "thick	3rd or 4th*	550°F (288°C)	8:00	6:00	170°F (77°C)	Well
Chicken - Bone In	3rd	450°F (232°C)	20:00	10:00	170°F (77°C)	Well
Chicken Boneless	3rd or 4th*	450°F (232°C)	8:00	6:00	170°F (77°C)	Well
Fish	3rd	500°F (260°C)	As directed As directed		170°F (77°C)	Well
Shrimp	3rd	550°F (288°C)			170°F (77°C)	Well
Hamburger 1" thick	3rd or 4th*	550°F (288°C)	9:00	7:00	160°F (71°C)	Medium
	3rd or 4th*	550°F (288°C)	10:00	8:00	170°F (77°C)	Well

*When broiling in the top oven rack position use an offset oven rack.

** The U.S. Department of Agriculture states, "Rare fresh beef is popular, but you should know that cooking it to only 140°F (60°C) means some food poisoning organisms may survive." (Source: Safe Food Book, Your Kitchen Guide, USDA Rev. June 1985.) The lowest temperature recommended by the USDA is 145°F (63°C) for medium rare fresh beef. For well done 170°F (77°C)

Setting Convection Roast

Convection roast combines a cook cycle with the convection fan and element to roast meats and poultry. Heated air circulates around the food from all sides, sealing in juices and flavors. Foods are crisp brown on the outside while staying moist on the inside. Do not cover food during convection roast. Preheating is not necessary.

To set the convection roast feature at 375°F:

1. Press **Upper or Lower Oven**.
2. Press **Conv Roast**. The display will show **350.°**



3. Enter the desired roasting temperature using the numeric keypad **3 7 5**.
4. Press **START**. As the oven begins roasting the actual temperature and the fan icon will be displayed.



5. Press **STOP** to cancel convection roast at any time.

Roasting rack instructions (if equipped)

When preparing meats for convection roasting, use broiler pan and insert along with the roasting rack. The broiler pan will catch grease spills and the insert will prevent grease splatters. The roasting rack will allow the heat to circulate around the meat.

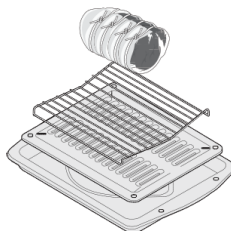

- Place oven rack on bottom or next to the bottom rack position. Make sure the roasting rack is securely seated on the insert in the broiler pan. Do not use the broiler pan without the insert. Do not cover the insert with aluminum foil.
- Position food (fat side up) on the roasting rack. Place the broiler pan on the oven rack. When roasting chicken use a deep pan instead.

WARNING Do not use the roasting rack when broiling.

Setting Cakes and Breads

The Cakes and Bread functions are designed to give optimum baking performance for Cakes or Breads. These work well for baking cakes, brownies, pies (fresh or frozen), baked custards, cheesecakes, breads, rolls, biscuits, muffins and corn bread.

The Cakes function provides a preheat with a gentle cycling of heat giving cakes more volume and allowing delicate foods to cook more evenly. The Breads function adds a special preheat feature to the bake cycle that thoroughly heats the oven from top to bottom to give more evenly browned foods.

To set the Cakes or Breads features with a default temperature of 350°F (177°C):

1. Arrange interior oven racks when cool. Preheat oven as desired and place food in oven.
2. For Cakes, press the Cakes Breads until **CAKES** appears in the oven control display.
3. For Breads, press the Cakes Breads until **BREADS** appears in the oven control display

Press **START**.



Figure 31: Oven set baking frozen cakes



Figure 32: Oven set for baking bread

4. Press **STOP** to cancel at any time.

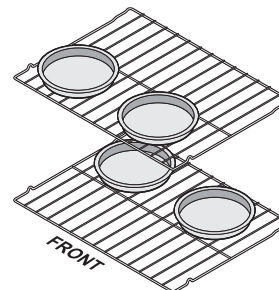

Figure 33: Suggested pan settings for cakes and breads on multiple racks. For single rack baking place rack in middle of oven.

Setting Oven Controls

Meat Probe

The Meat Probe feature is only available in the upper oven. When cooking meat such as roasts, hams or poultry, use the meat probe function to check the internal temperature without any guesswork. For some foods, especially poultry and roasts, testing the internal temperature is the best method to insure properly cooked meats.

Important note:

- Use only the meat probe supplied with appliance. Using any other probe or device may result in damage to appliance and the meat probe receptacle.
- Never leave or store meat probe inside oven.
- Handle the meat probe carefully when inserting and removing from food or probe receptacle. Do not use tongs to pull on meat probe cable when inserting or removing from food or receptacle.
- Defrost food completely before inserting meat probe to avoid damaging probe.
- To avoid possibility of burns, after cooking carefully unplug meat probe using a pot holder to protect hands.

Proper meat probe placement:

Always insert meat probe so that the probe tip rests in the center of the thickest part of meat. Do not allow meat probe to touch bone, fat, gristle or cookware.

For bone-in ham or lamb, insert meat probe into the center of lowest large muscle or joint. For dishes such as meat loaf or casseroles, insert meat probe into center of food. When cooking fish, insert meat probe just above the gill.

For whole poultry or turkey, insert meat probe into the thickest part of the bird (Figure 34).

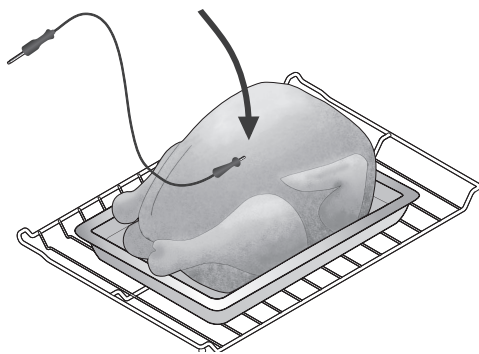

Figure 34: Probe placement in poultry

Important note:

Changing how the oven reacts after reaching the target temperature must be done before starting the cooking process.

To set meat probe:

1. Prepare the food and properly insert the temperature probe into the food. Do not preheat or start cooking before properly inserting the meat probe. Probe should be inserted into the food and receptacle while the oven is still cool.
2. Place the prepared food on the desired oven rack position and slide into the oven.
3. Plug the meat probe into the probe receptacle located at the top of the upper oven cavity.
4. When the meat probe is correctly plugged in to receptacle, the probe icon will illuminate in the oven control display.
5. Press **START** to accept the meat probe target temperature. Close the oven door.
6. Set the oven control for bake, conv bake or conv roast and the desired oven temperature. The meat probe cannot be set with broil or self clean.
7. To set the target temperature press **Meat Probe** once then enter the desired target internal temperature using the numeric keypad (default setting is 170°F/ 77°C).
8. During the cooking process the actual meat probe temperature will display by default. To view the target temperature press the **Meat Probe** key once. The display will show the actual (internal) meat probe temperature. If the target temperature needs to be changed during the cooking process, press **Meat Probe** once and use the numeric keypad to adjust the target temperature. Press **START** to accept any change.
9. The oven control will provide three beeps when the internal target temperature is reached. By default the oven will automatically change to Warm & Hold and will maintain the oven temperature at 170° F (77°C). Instructions for changing how the oven reacts after reaching the internal target temperature may be found later in this section.
10. Press **STOP** to cancel cooking at any time.

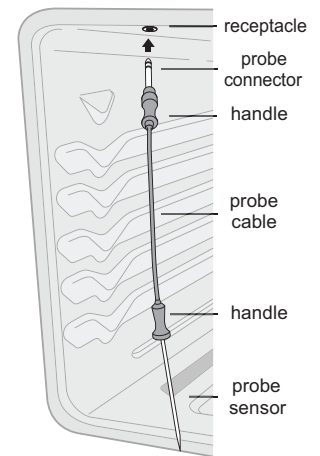

To set the oven to continue cooking after reaching the probe target temperature:

1. Press **Meat Probe** and hold for 6 seconds.
2. Press **Self Clean** until the **Continu** message appears.
3. Press  to accept.

To set the oven to cancel cooking and automatically start Warm & Hold after reaching the probe target temperature:

1. Press **Meat Probe** and hold for 6 seconds.
2. Press **Self Clean** until the **CAnCEL** message appears.
3. Press  to accept.



Figure 35: Probe set to continue cooking (L) and to cancel (R)

Minimal Internal Cooking Temperatures

Food type	Internal temperature
Beef, veal, lamb-roasts, steak and chops	
Medium	160°F (71°C)
Well done	170°F (77°C)
Fresh pork-roasts, steaks and chops	
Medium	160°F (71°C)
Well done	170°F (77°C)
Ham	
	160°F (71°C)
Poultry	
Whole chicken, turkey	165°F (74°C)
Poultry breasts, roasts	165°F (74°C)
Stuffing (cooked alone or in bird)	165°F (74°C)
Leftovers	165°F (74°C)

Information courtesy the U.S. Department of Agriculture Food Safety and Inspection Service.

Setting Warm & Hold™

The **Warm & Hold** key turns on the Warm & Hold feature and will maintain an oven temperature of 170°F (77°C). The Warm & Hold feature will keep oven baked foods warm for serving up to 3 hours after cooking has finished. After 3 hours Warm & Hold will turn the oven off.

The Warm & Hold feature may be used without any other cooking operations or can be used after cooking has finished using bake, convection bake, and convection roast.

Warm & Hold may be used with a timed bake if you wish to have the feature turn on automatically when cooking has finished. The timed bake feature requires a start time and cook time. With this information the control can calculate the time when cooking will complete and can then start Warm & Hold automatically.

⚠ WARNING Food poisoning hazard. Do not let food sit for more than one hour before or after cooking. Doing so can result in food poisoning or sickness.

To set Warm & Hold

1. Arrange oven racks and place food in oven.
2. Press **Upper** or **Lower Oven**.
3. Press **Warm & Hold**. **Hld** will appear in the display.



Note: If no key is touched within 25 seconds, the request to turn on the Warm & Hold feature will be cancelled.

4. Press . **Hld** will remain on and the oven icon will appear in the display.



5. To cancel Warm & Hold at any time press .

Note: The Warm & Hold feature will automatically turn off after three hours.

Setting Oven Controls

To set Warm & Hold to turn on automatically:

1. Arrange oven racks and place food in oven.
2. Set the oven for timed bake or timed bake with a delay start.
3. Press **Warm & Hold**. **HLd** will appear in the display.



Note: If no key is touched within 25 seconds, the request to turn on the Warm & Hold feature will be cancelled.

4. Press **START**. **WARM** will stop flashing and the programmed temperature will appear in the display.



5. When the timed bake has finished Warm & Hold will turn on automatically.



Figure 36: Oven display showing Warm & Hold operation

Slow Cook

The slow cook feature may be used to cook foods more slowly, at lower oven temperatures, and is ideal for roasting beef, pork and poultry. Slow cooking meats may result in the exterior of meats becoming dark but not burnt. This is normal.

There are two settings available, high (Hi) or low (Lo). The low setting is best for cooking foods from 8 to 9 hours or longer.

The high setting is best for cooking foods from 4 to 5 hours. The maximum cook time for the slow cook feature is 12 hours unless the oven control has been changed to the continuous bake mode. This feature may be used with the additional settings of a cook time or a delayed start.

Cooking and Preparation Tips for Slow Cook

- Completely thaw all frozen foods before cooking. When using a single rack, place in position 2 or 3. Position multiple racks to accommodate size of cooking utensils when cooking multiple food items.
- Do not open the oven door often or leave the door open when checking foods. If the oven heat escapes often, the cook time may need to be extended.
- Cover the foods to keep them moist or use a loose or vented type cover to allow foods to turn crisp or brown. Cook times will vary depending on the weight, fat content, bone and the shape of the food. Use the recipe's recommended food temperature and a food thermometer to determine when the food is done.
- Preheating the oven will not be necessary when using the slow cook feature. Add any cream or cheese sauces during the last hour of cooking.

WARNING Food poisoning hazard. Do not let food sit for more than one hour before or after cooking. Doing so can result in food poisoning or sickness.

To set the slow cook:

1. Place food in oven.
2. Press **Upper** or **Lower Oven**.
3. Press **Slow Cook**. **SLO** and **HI** will appear in the display.



4. If **Lo** setting is preferred, press **Slow Cook** again. **Lo** will appear in the display.



5. Press  to activate the slow cook feature.
6. If desired, add cook time or delay start settings at this time..

Accent Light



Figure 37: Accent light feature located beneath oven controls

Your appliance includes a decorative accent light at the base of the oven controls panel. The accent light provides a theatre style intensity feature that slowly increases brightness at turn on and slowly fades when turning off.

When the accent light is off, the light operates in automatic mode. This means the accent light will turn on automatically when an oven, cooktop function or feature such as the timer have been activated. The accent light will turn off automatically when these functions or features are no longer active.

When the Accent Light is off, it may be manually turned on by pressing **Accent Light** once. When the accent light has been manually turned on, it will remain on until manually turned off by pressing **Accent Light** again. The accent light brightness is adjustable from 0 to 100 percent.

To adjust Accent Light brightness:

1. Press and hold **Accent Light** until an acceptance tone sounds (about 6 seconds).
2. The default brightness setting of 100 will appear in the display ([Figure 38](#)).
3. Using the numeric keypad, enter any digit from 0 to 100 to change the brightness level. (Entering 0 ([Figure 39](#)) will effectively turn the accent light off until the brightness level is adjusted to a higher level.)
4. Press  to save the desired brightness setting.

Note: To check the brightness level after adjusting, press the Accent Light key and hold for about 6 seconds until the brightness level appears. For further adjustment repeat steps 1, 3 and 4.



Figure 38: Accent Light at highest intensity



Figure 39: Accent Light at lowest setting

Setting Oven Controls

Setting the Sabbath Feature (for use on Jewish Sabbath and Holidays)

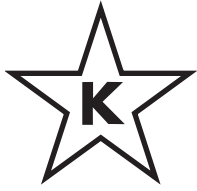

The **Cook Time** and **Delay Start** keys are used to set the Sabbath feature.

For further assistance, guidelines for proper usage, and a complete list of models with the Sabbath feature, please visit the web at www.star-k.org.

The Sabbath feature may only be used with the bake function. Once the oven is properly set using bake with the Sabbath feature active, the oven will remain on until cancelled. The Sabbath feature overrides the factory preset 12 Hour Energy Saving feature.

If the oven light is needed during the Sabbath, press the oven light before activating the Sabbath feature. Once the oven light is turned on and the Sabbath feature is active, the oven light will remain on until the Sabbath feature is turned off. If the oven light needs to be off, be sure to turn the oven light off before activating the Sabbath feature.

⚠ WARNING Food poisoning hazard. Do not let food sit for more than one hour before or after cooking. Doing so can result in food poisoning or sickness.

To program the oven to begin baking immediately and activate the Sabbath feature (example: baking at 350°F):

1. Be sure that the clock is set to correct time of day and place food in oven. Select **Upper** or **Lower Oven**.
2. Press **Bake**.



Figure 40: Default temperature of 350 appears in display

3. Press **START**. The actual oven temperature will appear in the display. **Note:** If a surface burner needs to be on, activate the burner at this time..



Figure 41: Display showing minimum temperature of 100

4. If you desire to set the oven control for a cook time or delay start do so at this time. If not, skip to the next step. Refer to the “[Setting Cook Time](#)” or “[Setting Delay Start](#)” section for complete instructions. Remember the oven will shut down after using cook time or delay start and therefore may only be used once during the Sabbath and Jewish Holidays. The maximum delay start time is 11 hours and 59 minutes.

5. The oven will turn on and begin heating. If you need to set both ovens for the Sabbath, set both at this time.
6. Press and hold both the **Cook Time** and **Delay Start** keys for at least 3 seconds. **SAb** will appear in the display. Once **SAb** appears in the display the oven control will no longer beep or display any further changes. The oven is properly set for the Sabbath feature.



Figure 42: Display showing oven set for Sabbath

Note: You may change the oven temperature once baking has started.

Press **Bake**, enter the oven temperature change (170 to 550°F) and then press **START** twice (for Jewish Holidays only).

Important: Remember that the oven control will no longer beep or display any further changes once the oven is set for the Sabbath feature.

The oven may be turned off at any time by first pressing **STOP** (this will turn the oven off only).

To turn off the Sabbath feature press and hold both the **Cook Time** and **Delay Start** keys for at least 3 seconds. This also turns off the oven. **SAb** will disappear from the display.

Power failure while using Sabbath feature:

Should you experience a power failure or interruption, the oven will shut off. When power is returned, **SF** (Sabbath Failure) will be displayed and the oven will not turn back on automatically. If your food was nearly fully cooked, you may allow the trapped heat in the oven to finish the cooking process. Otherwise, you should remove the food when the power failure occurs, because you may only start the oven once during the Sabbath and Jewish Holidays.

After the Sabbath observance turn off the Sabbath feature. Press and hold both the **Bake Time** and **Delay Start** keys for at least 3 seconds. **SAb** will disappear from the display and the oven may be used with all normal functions.

For further assistance, guidelines for proper usage, and a complete list of models with the Sabbath feature, please visit the web at www.star-k.org.

Setting Recipe Recall

This feature will only recall a bake, convection bake, convection roast, slow cook, or cook time. This feature will not work with any other function. One recipe can be saved for each oven.

To program the oven to begin baking immediately and record a recipe (Bake at 425°F):

1. Select **Upper** or **Lower** oven. Press **Bake**.
2. Press **4 2 5**.



3. Press and hold **START** until a beep indicates that the recipe has been recorded for future recall. If you do not wish to continue cooking at this time press **STOP**.

To begin baking using a stored recipe:

1. Press **UPPER** or **LOWER** oven.
2. Press **Bake** or any other function where recipe has been saved and then press .
3. Place food in oven.
4. The temperature (and cook time if programmed) is recalled, the oven will begin cooking the recorded recipe.

Restoring Factory Default Settings

Your appliance is programmed with default control settings. Over time, the following options may have been changed since the appliance was new. If you choose to restore default settings, all user preferences will be restored to their original settings.

- 12 or 24 hour display mode
- Continuous Bake or 12 Hour Energy Savings mode
- Silent or audible control
- Oven temperature display (Fahrenheit or Celsius)
- Oven temperature adjustments (UPO)
- Stored recipes
- Meat Probe setting
- Accent Light setting

To restore oven control to factory default settings:

1. When the oven is in idle and no cooking function is in operation, press and hold the **7** key until the acceptance tone sounds (about 6 seconds).
2. Press **START**. The control is now reset to default settings.

Adjusting Oven Temperature

The temperature in the oven is pre-set at the factory. Before adjusting, be sure to follow recipe times and temperatures. Test a recipe by using a temperature setting higher or lower than the recommended temperature.

Important: Do not use thermometers such as those found in grocery stores to check the temperature settings inside the oven. These thermometers may display temperatures that vary greatly from the actual temperature.

The baking results should help you to decide how much of an adjustment is needed. If you think the oven is cooking too hot or too cool, you can adjust the actual oven temperature to be 35°F (19°C) more or 35°F less than the default setting of 0.

To adjust the oven temperature higher by 30°:

1. Press **Broil** for 6 seconds. **UPO 0** will appear in the display.
2. Press the numeric keypad **3 0**.
3. Press  to accept the new temperature change offset or press **STOP** to reject the change if necessary.

To adjust the oven temperature lower by 30°:

1. Press **Broil** for 6 seconds. **UPO 0** will appear in the display.
2. Press the numeric keypad **3 0**.
3. Press the **Self Clean key** to change the 30 to a **- 30**. By pressing **Self Clean** the value will change from plus to minus or from minus to plus.
4. Press  to accept the temperature change offset or press **STOP** to reject the change if necessary.

Setting Oven Controls

Self Cleaning Oven

A self cleaning oven cleans itself with very high temperatures (well above cooking temperatures) which eliminate soils completely or reduces them to a fine powdered ash you can wipe away with a damp cloth.

Adhere to the following cleaning precautions before starting a self clean:

- Allow the oven to cool before cleaning. It is recommended that all oven racks and oven accessories be removed before starting a self clean cycle to avoid damage to the racks. This will ensure the glide ability of the Glide rack and protect the bearings.
- Wear rubber gloves when cleaning any exterior parts of the oven manually.
- Do not use oven cleaners or oven protective coatings in or around any part of the oven interior.
- Do not use any cleaning materials on the oven door gasket. Doing so could cause damage.
- Remove all utensils and any aluminum foil. These items cannot withstand high cleaning temperatures.
- Remove any excess soil and debris from oven bottom before starting self clean. Large spillovers can cause heavy smoke or fire when subjected to high temperatures.
- Before starting the self clean cycle, hand clean any soil from the oven frame, the door liner outside the oven door gasket, and the small area at the front center of the oven. Clean with soap and water. Burned-on residue can be cleaned off with a stiff nylon brush and water or nylon scrubber.
- Plastic or foods with a high sugar content: These types of soils need be removed immediately if spilled or melted onto the ceramic cooktop surface. Permanent damage (such as pitting of the cooktop surface) may occur if not removed immediately. After turning the surface elements off, use a razor blade scraper or a metal spatula with a mitt and scrape the soil from the hot surface (as illustrated). Allow the cooktop to cool, and use the same method for heavy or burned on soils.
- This model comes with lubricated porcelain oven racks, which can remain in the oven during the self-clean cycle. Do not clean this vegetable oil lubrication off the racks. It is important that the sides of the oven racks always have a light coating of vegetable oil. To maintain optimal rack performance, re-apply a thin layer of vegetable oil to the sides of the rack after every self-clean cycle or when the rack becomes difficult to slide.

Self Clean

⚠ WARNING During the self cleaning cycle, the outside of the range can become very hot to the touch. Do not leave small children unattended near the appliance.

⚠ WARNING The health of some birds is extremely sensitive to the fumes given off during the self clean cycle of any range. Move birds to another well ventilated room.

⚠ CAUTION Do not line the oven walls, racks, bottom or any other part of the appliance with aluminum foil. Doing so will destroy heat distribution, produce poor baking results and cause permanent damage to the interior (aluminum foil will melt to the interior surface of the oven).

⚠ CAUTION Do not force the oven door open. This can damage the automatic door locking system. Use caution when opening the door after the self clean cycle is completed. The oven may still be very hot.

⚠ CAUTION The oven bake and broil elements may appear to have cooled after the self clean is over and the door can be opened. These elements may still be hot and burns may occur if these elements are touched before they have cooled.



Figure 43: Care in cleaning oven by hand

Note: Do not clean the oven door gasket. The woven material of the oven door gasket is essential for a good seal. Care should be taken not to rub, damage or remove the gasket.

See additional cleaning information for the oven door in the General Care and Cleaning section.

To Start Self Clean

The **Self Clean** key controls the self clean feature. If you are planning to use the oven directly after a self clean cycle remember to allow time for the oven to cool down and the oven door to unlock. This normally takes about one hour. A 3 hour self clean cycle will take about 4 hours to complete. It is recommend to use a 2 hour self clean cycle for light cleaning, a 3 hour cycle for average cleaning, 4 hours for a heavy cleaning.

CAUTION When the self clean cycle is over, stand to the side of the oven when opening the door to allow hot air or steam to escape. When the oven is set for a self clean, do not force the oven door open. This can damage the automatic door locking system. Use caution and avoid possible burns when opening the door after the self cleaning cycle has completed. The oven may still be very hot.

To start an immediate 3 hour self clean cycle:

1. Be sure clock is set for correct time of day and door is closed and the cooktop is not active.
2. Press **Upper** or **Lower Oven**.
3. Press **Self Clean**. **CLEAN** will flash and **3:00** will show in the display. The oven will automatically clean for a 3 hour period.

Note: if a 2 or 4 hour clean time is desired, press **2 0 0** for 2 hour or **4 0 0** for a 4 hour clean time.



4. Press **START**. The **DOOR, LOCKED** icon and **REMOVE RACKS** will flash and the **CLEAN** icon and the letters **CLn** will remain in the display. Press **START** again to begin CLEAN.

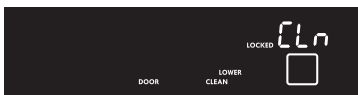

5. As soon as the control is set, the motor driven oven door lock will begin to close automatically. Do not open the oven door while the lock motor is running or when any locking indicators or displays are showing. Allow 15 seconds for the oven door to lock. Once the door has been locked the **DOOR LOCKED** indicator light will stop flashing and remain on. Also, the oven icon will appear in the display.

Note: If at this time you wish to delay the self clean starting time, follow steps 6 through 9:

6. Press **Delay Start**.



7. Enter the start time numbers **4 3 0** and press **START**. **CLEAN, DELAY, LOCK, and DOOR** will be displayed.



8. The control will start the self clean at the set delay start time selected and the **DELAY** message will disappear.



When the self clean is over:

1. **HOT** will appear in the display. The time of day, the **DOOR LOCKED** and **CLEAN** icon will remain in the display.
2. Once the oven has cooled down for approximately one hour, and the **DOOR LOCKED** icon is no longer displayed, the oven door can then be opened.

Stopping or Interrupting a Self Cleaning cycle

If it becomes necessary to stop or interrupt a self cleaning cycle due to excessive smoke or fire in the oven:

1. Press **STOP**.
2. The oven door can only be opened after the oven has cooled down for approximately one hour and the **DOOR LOCKED** icon is no longer displayed.

Note: If your clock is set for normal 12 hour display mode the delayed self clean cycle can never be set to start more than 12 hours in advance. To set for delayed self clean cycle 12 to 24 hours in advance set the control for the 24 hour time of day display mode.

Care and Cleaning

Cleaning Various Parts of Your Oven

Important note: Before cleaning any part of the oven, be sure all controls are turned off and the oven is cool. Remove spills and any heavy soiling as soon as possible. Regular cleaning will reduce the difficulty of major cleaning later.

Surface Type	Recommendation
Aluminum and Vinyl	<ul style="list-style-type: none">Use hot, soapy water and a cloth. Dry with a clean cloth.
Painted body parts	<ul style="list-style-type: none">Use a soft cloth and clean with mild dish detergent and water or a 50/50 solution of vinegar and water. Follow by rinsing the area with clean water; dry and polish with a soft cloth. Glass cleaners may be used if sprayed on a soft cloth first. Do not spray liquids directly on the oven control and display area.
Painted decorative trims	
Oven control panel	
Easy Clean™ Stainless Steel	<ul style="list-style-type: none">Your oven finish may be Easy Clean™ Stainless Steel (some models). Clean the stainless with warm soapy water using a clean sponge or cloth. Rinse with clean water and dry with a soft clean cloth. Do not use any store bought cleaners like stainless steel cleaners or any other types of cleaners containing any abrasive, chlorides, chlorine, or ammonia. It is recommended to use mild dish soap and water or a 50/50 solution of water and vinegar.
Stainless Steel	
Porcelain enamel broiler pan and insert (available by mail order)	<ul style="list-style-type: none">Gentle scouring with a soapy scouring pad will remove most spots. Rinse with a 1:1 solution of clear water and ammonia. If necessary, cover difficult spots with an ammonia-soaked paper towel for 30 to 40 minutes. Rinse with clean water and a damp cloth, and then scrub with a soap-filled scouring pad. Rinse and wipe dry with a clean cloth. Remove all cleaners or the porcelain may become damaged during future heating.
Door liner and body parts	
Porcelain Oven Racks	<ul style="list-style-type: none">This model comes with lubricated porcelain oven racks, which can remain in the oven during the self-clean cycle. Do not clean this vegetable oil lubrication off the racks. It is important that the sides of the oven racks always have a light coating of vegetable oil. To maintain optimal rack performance, re-apply a thin layer of vegetable oil to the sides of the rack after every self-clean cycle or when the rack becomes difficult to slide.
Oven door	<ul style="list-style-type: none">Use soap and water to thoroughly clean the top, sides, and front of the oven door. Rinse well. You may use a glass cleaner on the outside glass of the door. Do not immerse the door in water. Do not spray or allow water or the glass cleaner to enter the door vents. Do not use oven cleaners, cleaning powders, or any harsh abrasive cleaning materials on the outside of the oven door. Do not clean the oven door gasket. On self clean models, the oven door gasket is made of a woven material which is essential for a good seal. Care should be taken not to rub, damage, or remove this gasket.
Oven Interior	<ul style="list-style-type: none">Gentle scouring with a soapy scouring pad will remove most spots. Rinse and wipe dry with a clean cloth. Remove all cleaners or the porcelain may become damaged during future heating.
Cooktop Care and Cleaning	<ul style="list-style-type: none">Be sure to read all information on how to care for your cooktop contained in the “Cooktop Maintenance” and “Cooktop Cleaning” sections starting on page 35.Do not use spray oven cleaners on the cooktop. See “Cooktop Maintenance” on page 35. Do not use a cooktop cleaner on a hot cooktop. The fumes can be hazardous to your health and can chemically damage the ceramic-glass surface.
Ceramic Cooktop	
Cooktop Surface Burners	

Cooktop Maintenance

Consistent and proper cleaning is essential to maintaining your ceramic glass cooktop.

Prior to using your cooktop for the first time, apply the recommended CookTop® Cleaning Creme to the ceramic surface (on the web visit www.sears.com for replacement cooktop cleaner, item number 40079). Buff with a non-abrasive cloth or non-abrasive cleaning pad. This will make cleaning easier when soiled from cooking. The special cooktop cleaning cream leaves a protective finish on the glass to help prevent scratches and abrasions.

Sliding aluminum or copper clad bottom pans on the cooktop can cause metal markings on the cooktop surface. These marks should be removed immediately after the cooktop has cooled using the cooktop cleaning cream. Metal marks can become permanent if not removed prior to future use.

Cookware (cast iron, metal, ceramic or glass) with rough bottoms can mark or scratch the cooktop surface.

Cooktop care precautions:

- Never slide anything metal or glass across the cooktop.
- Do not use cookware with dirt or dirt build up on bottom; replace with clean cookware before using.
- Never use your cooktop as a cutting board or work surface in the kitchen.
- Do not cook foods directly on the cooktop surface without a pan.
- Be careful never to drop heavy or hard objects on the ceramic glass cooktop, they may cause it to crack.

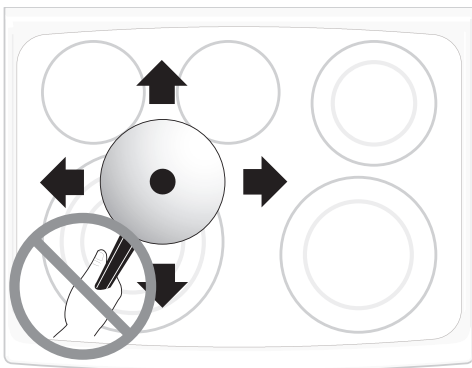

Figure 44: Do not slide pans

Cooktop Cleaning

⚠ WARNING Do not use a cooktop cleaner on a hot cooktop. The fumes can be hazardous to your health, and can chemically damage the ceramic glass surface.

⚠ CAUTION Before cleaning the cooktop, be sure the controls are turned to off and the cooktop is cool. The glass surface could be hot and burns may occur if the glass surface is touched before it has cooled sufficiently.

For light to moderate soil:

Apply a few drops of CookTop® Cleaning Creme directly to the cooktop. Use a paper towel or use a non-abrasive cleaning pad to clean the entire cooktop surface. Make sure the cooktop is cleaned thoroughly, leaving no residue.

For heavy, burned on soil:

Apply a few drops of CookTop® Cleaning Creme directly to the soiled area. Rub the soiled area using a non-abrasive cleaning pad, applying pressure as needed. Do not use the pad you use to clean the cooktop for any other purpose.

If soils remain, carefully scrape soils with a metal razor blade scraper, holding scraper at a 30 degree angle to the surface. Remove loosened soils with cooktop cleaning cream and buff surface clean.

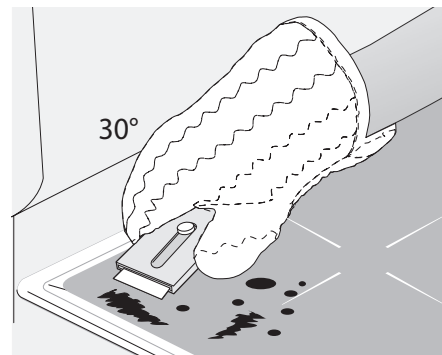

Figure 45: Using razor blade to remove burned on matter

Plastic or foods with a high sugar content:

These types of soils need be removed immediately if spilled or melted onto the ceramic cooktop surface. Permanent damage (such as pitting of the cooktop surface) may occur if not removed immediately. After turning the surface elements off, use a razor blade scraper or a metal spatula with a mitt and scrape the soil from the hot surface (Figure 45). Allow the cooktop to cool, and use the same method for heavy or burned on soils.

Care and Cleaning

Care and Cleaning

When cleaning the cooktop be sure to follow these guidelines:

- Do not use abrasive cleaners and scouring pads, such as metal and some nylon pads. They may scratch the cooktop, making it more difficult to clean.
- Do not use harsh cleaners like chlorine bleach, ammonia, or oven cleaners as they may etch or discolor the cooktop.
- Do not use dirty sponges, cloths or paper towels, as they can leave soil or lint on the cooktop which can burn and cause discoloration.

Note:

Damage to the ceramic glass cooktop may occur if you use an abrasive type cleaning pad. Only use cleaning products that have been specifically designed for ceramic glass cooktops.



General Cleaning

Refer to the “Cleaning Various Parts of Your Oven” recommendation table in this section for more detailed information about cleaning specific parts of the range.

CAUTION Before manually cleaning any part of the range, be sure all controls are turned off and the range is cool. The range may be hot and can cause burns.

CAUTION Ammonia must be rinsed before operating the oven. Provide adequate ventilation.

Aluminum Foil and Utensils

WARNING Never cover any slots, holes or passages in the oven bottom or cover an entire oven rack with materials such as aluminum foil. Aluminum foil linings may trap heat, causing a fire hazard.

WARNING Protective Liners — Do not use aluminum foil to line the oven bottom. Only use aluminum foil as recommended in this manual. Improper installation of these liners may result in risk of electric shock, or fire.

- Aluminum foil - Use of aluminum foil on a hot cooktop can damage the cooktop. Do not use thin aluminum cooking utensils or allow aluminum foil to touch the surface elements under any circumstances.
- Aluminum cookware and utensils - The melting point of aluminum is much lower than that of other metals. Care must be taken when aluminum pots or pans are used on the cooktop. If aluminum pans are allowed to boil dry when using the cooktop, not only will the utensil be damaged or destroyed, but it may fuse to, break or mark the ceramic glass surface, permanently damaging the cooktop surface.

Replacing the Oven Light

CAUTION Be sure the oven is unplugged and all parts are cool before replacing oven light.

The interior oven light is located on the upper left side of the oven cavity. (See [Figure 46](#)).

To replace the oven interior light bulb:

Important note:

Use a paper towel or cotton glove while handling the new bulb when installing.

1. Turn electrical power off at the main source or unplug the appliance. Carefully remove glass shield.
2. Replace bulb with a new 40 watt halogen bulb. Replace glass shield.
3. Turn power back on again at the main source (or plug the appliance back in). Be sure to reset the time of day on the clock.

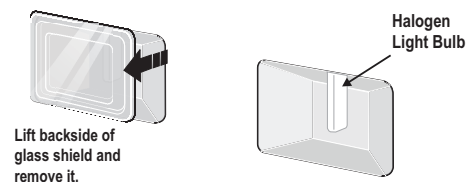

Figure 46: Replacing oven light

Porcelain enameled glide racks

⚠ CAUTION Handle oven racks only when they are cool. After cooking or after the self clean cycle, racks will be very hot and can cause burns.

Important notes:

- It is recommended to remove all racks from the oven during self-clean cycles, but they may be left in the oven if they are soiled. After a self clean cycle, the glide racks should be treated with graphite lubrication.
- Do not use cooking oil, cooking spray, or other oil-based lubrication products on the glide rack extension tracks. Use only the graphite lubrication in this area. To order graphite lubrication, contact your installer, servicer, or dealer.
- It is important that the parts of the rack that contact the oven sides always have a light coating of vegetable oil. Apply a thin layer of vegetable oil to the sides of the rack after every self-clean cycle and when the rack becomes difficult to reposition in the oven.

To lubricate the glide rack:

1. Remove the rack from the oven. Place the rack on a large flat surface covered with newspaper or scrap cloth. Fully extend the rack.
2. Wipe away debris and crumbs from the glide track using a cloth or sponge.

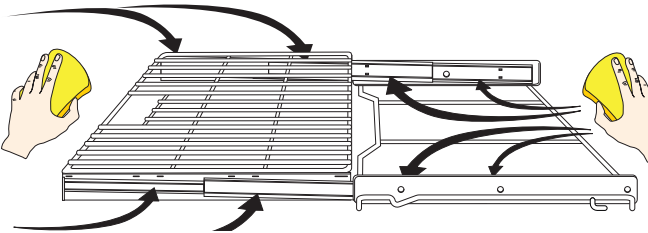

3. Shake graphite lubrication very well before applying. Place four drops of graphite lubrication along the bottom tracks (as shown in area circled in figure below). Repeat on both sides of the glide rack.

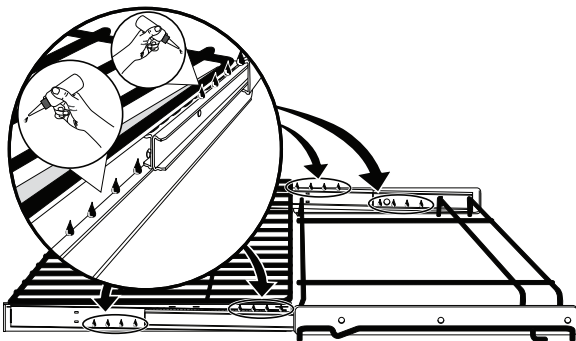

4. Extend and return the glide rack several times to distribute the lubricant.

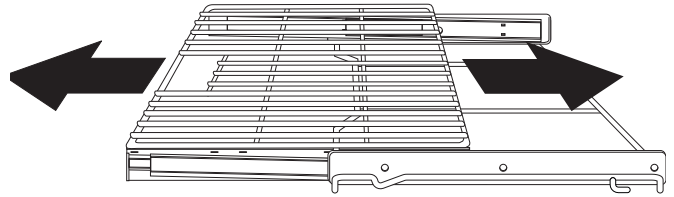

5. Turn glide rack over. Place four drops of graphite lubrication along the top tracks. Repeat on both sides of the glide rack.

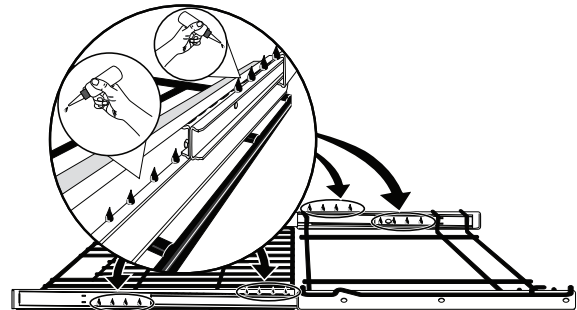

6. Extend and return the glide rack several times to distribute the lubricant.

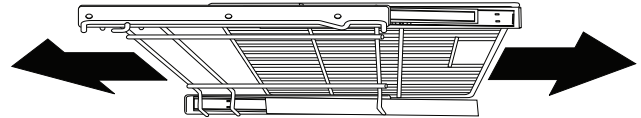

7. Apply a thin layer of cooking oil to the outer frame of the glide rack. Keeping the frame lightly lubricated allows the entire rack to slide easily when changing rack positions.

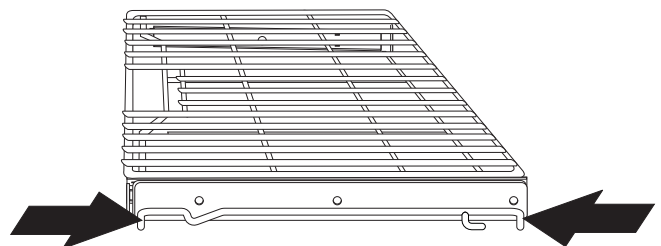

8. Replace rack in oven right-side up.

Care and Cleaning

Removing and Replacing the Oven Door

⚠ CAUTION The door is heavy. For safe, temporary storage, lay the door flat with the inside of the door facing down.

To remove the oven door:

1. Open oven door completely, horizontal with floor (See [Figure 47](#)).
2. Pull the door hinge locks on both left and right door hinges down from the oven frame completely toward the oven door (See [Figure 48](#)). A tool such as a small flat-blade screwdriver may be required.
3. Firmly grasp both sides of oven door along the door sides. Do not use the oven door handle (See [Figure 49](#)).
4. Close the door to approximately 10 degrees from the oven door frame.
5. Lift the oven door hinge arms over the roller pins located on each side of the oven frame (See [Figure 49](#)).

To Replace Oven Door:

1. Firmly grasp both sides of oven door along the door sides. Do not use the oven door handle ([Figure 49](#)).
2. Holding the oven door at the same angle as the removal position ([Figure 49](#)), seat the hook of the hinge arm over the roller pins located on each side of the oven door frame ([Figure 50](#)). The hook of the hinge arms must be fully seated onto the roller pins.
3. Fully open the oven door, horizontal with floor ([Figure 47](#)).
4. Push the door hinge locks up toward and into the oven frame on both left and right oven door hinges to the locked position ([Figure 48](#)).
5. Close the oven door.

Important:

Special Door Care Instructions

- Most oven doors contain glass that can break.
- Do not close the oven door until all the oven racks are fully in place.
- Do not hit the glass with pots, pans, or any other object.
- Scratching, hitting, jarring, or stressing the glass may weaken its structure causing an increased risk of breakage at a later time.

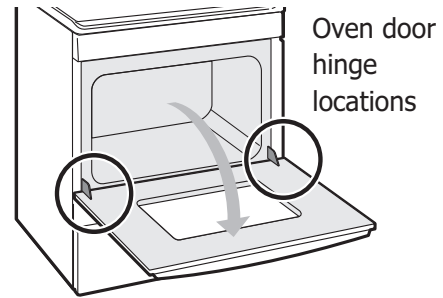

Figure 47: Door hinge location

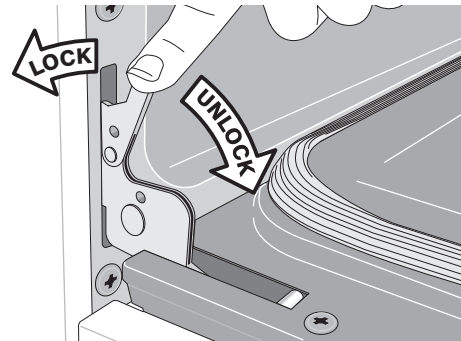

Figure 48: Door hinge locks

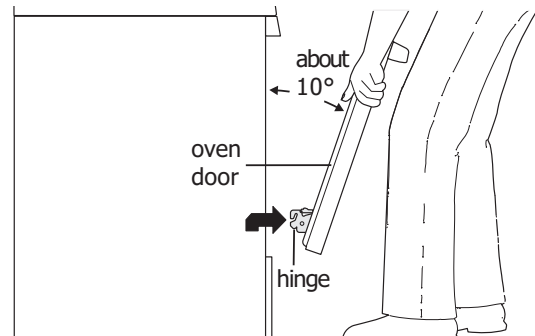

Figure 49: Holding door for removal

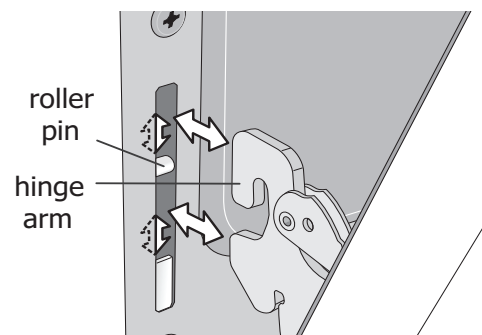

Figure 50: Location of hinge arm and roller pin





Before You Call

Oven Baking

For best cooking results, heat the oven before baking cookies, breads, cakes, pies or pastries, etc. There is no need to preheat the oven for roasting meat or baking casseroles.

The cooking times and temperatures needed to bake a product may vary slightly from your previously owned appliance.

Baking Problems and Solutions

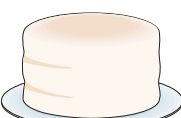
Baking Problems	Causes	Corrections
Cookies and biscuits burn on the bottom 	<ul style="list-style-type: none"> • Cookies and biscuits put into oven before the preheating time is completed. • Oven rack is overcrowded. • Dark pans absorb heat too fast. 	<ul style="list-style-type: none"> • Allow oven to preheat to desired temperature before placing food in oven. • Choose pan sizes that will permit 2" to 4" of air space (5.1 cm to 10.2 cm) on all sides when placed in the oven. • Use a medium weight baking sheet.
Cakes too dark on top or bottom 	<ul style="list-style-type: none"> • Cakes put in oven before preheating time is completed. • Rack position too high or too low. • Oven too hot. 	<ul style="list-style-type: none"> • Allow oven to preheat to the selected temperature before placing food in the oven. • Use proper rack position for baking needs. • Set oven temperature 25°F (13°C) lower than recommended.
Cakes not done in center 	<ul style="list-style-type: none"> • Oven too hot. • Incorrect pan size. • Pan not centered in oven. 	<ul style="list-style-type: none"> • Set oven temperature 25°F (13°C) lower than recommended. • Use pan size suggested in recipe. • Use proper rack position and place pan so there is 2" to 4" (5.1 cm to 10.2 cm) of space on all sides of pan.
Cakes not level 	<ul style="list-style-type: none"> • Oven not level. • Pan too close to oven wall or rack overcrowded. • Pan warped. 	<ul style="list-style-type: none"> • Place a marked glass measuring cup filled with water on the center of the oven rack. If the water level is uneven, refer to the installation instructions for leveling the oven. • Be sure to allow 2" to 4" (5.1 cm to 10.2 cm) of clearance on all sides of each pan in the oven. • Do not use pans that are dented or warped.
Foods not done when cooking time is over 	<ul style="list-style-type: none"> • Oven too cool. • Oven overcrowded. • Oven door opened too frequently. 	<ul style="list-style-type: none"> • Set oven temperature 25°F (13°C) higher than suggested and bake for the recommended time. • Be sure to remove all pans from the oven except the ones to be used for baking. • Open oven door only after shortest recommended baking time.

Before You Call

Solutions to Common Problems

Before you call for service, review the following list. It may save you time and expense. Possible solutions are provided with the problem listed:

Problem	Solution
Poor baking results	<ul style="list-style-type: none">• Many factors will have an effect on baking results. Use proper oven rack position. Center food in the oven and space pans to allow air to circulate. Preheat oven to the set temperature before placing food in the oven. Try adjusting the recipe's recommended temperature or baking time. See "Adjusting Oven Temperature" on page 31 if you feel the oven is too hot or cold.
Oven does not operate	<ul style="list-style-type: none">• The time of day is not set. The oven clock must first be set in order to operate the oven.• Be sure oven controls are set properly. Review instructions for the desired cooking function in this manual.• Service wiring is not complete.
Oven light does not work	<ul style="list-style-type: none">• Be sure the oven light is secure in the socket. See "Replacing the Oven Light" on page 36.
Flames inside oven or smoking from oven vent	<ul style="list-style-type: none">• Excessive spills in oven. Grease or food spilled onto oven bottom or oven cavity. Wipe up excessive spills before starting oven. If flames or excessive smoke are present when using broil, see "Setting Broil" on page 24.
Self clean does not work	<ul style="list-style-type: none">• Oven control not set properly. Review Self Clean section.
Oven racks discolored or do not slide easily	<ul style="list-style-type: none">• Oven racks left in oven cavity during self clean. Always remove oven racks from oven cavity before starting a self clean cycle. Clean using a mild abrasive cleaner following manufacturer's instructions. Rinse with clean water, dry, and replace in oven.
Oven smokes excessively when broiling	<ul style="list-style-type: none">• Incorrect setting. Follow broiling instructions in "Setting Broil" on page 24• Meat too close to the broil element. Reposition broil rack to provide proper clearance between the meat and broil element. Remove excess fat from meat. Cut remaining fatty edges to prevent curling.• Grease build up on oven surfaces. Regular cleaning is necessary when broiling frequently. Grease or food splatters will cause excessive smoking.
Oven control panel beeps and displays any F or E code error	<ul style="list-style-type: none">• Oven control has detected a fault or error condition. Press STOP to clear the error code. Try bake or broil function. If the F or E code error repeats, turn off power to appliance, wait 5 minutes and then repower appliance. Set clock with correct time of day. Try bake or broil function again. If fault recurs, press STOP to clear.
Soil not completely removed after self clean	<ul style="list-style-type: none">• Self Clean was interrupted. Review Self Clean instructions.• Excessive spills on oven bottom. Clean before starting self clean.

Surface element is too hot or not hot enough	<ul style="list-style-type: none"> • Incorrect surface control setting. Adjust power level setting.
Surface element does not heat or does not heat evenly	<ul style="list-style-type: none"> • Be sure the correct surface control is turned on for element needed. • Lightweight or warped pans used. Use only flat, evenly balanced, medium or heavy-weight cookware. Flat pans heat better than warped pans. Cookware materials and weight of the material affect heating. Heavy and medium-weight pans heat evenly. Because lightweight pans heat unevenly, foods may burn easily.
Scratches or abrasions on cooktop surface	<ul style="list-style-type: none"> • Coarse particles such as salt or hardened soils between cooktop and utensils can cause scratches. Be sure cooktop surface and bottoms of utensils are clean before usage. Small scratches do not affect cooking and will become less visible with time. • Cleaning materials not recommended for ceramic-glass cooktop have been used. Apply the recommended CookTop® Cleaning Creme to the ceramic surface (on the web visit www.sears.com for replacement cooktop cleaner, item number 40079). Buff with a non-abrasive cloth or sponge. • Cookware with rough bottom was used. Use smooth, flat-bottomed cookware.
Brown streaks or specks on cooktop surface	<ul style="list-style-type: none"> • Boilovers are cooked onto surface. Use razor blade scraper to remove soil.
Appliance is not level	<ul style="list-style-type: none"> • Be sure floor is level, strong, and stable enough to adequately support range. If floor is sagging or sloping, contact a carpenter to correct the situation. • Poor installation. Place oven rack in center of oven. Place a level on the oven rack. Adjust leveling legs at base of appliance until the rack is level. Kitchen cabinet alignment may make range appear not level. Be sure cabinets are square and have sufficient room for appliance clearance.
Cannot move appliance easily. Appliance must be accessible for service	<ul style="list-style-type: none"> • Cabinets not square or are built in too tightly. Contact builder or installer to make appliance accessible. • Carpet interferes with appliance. Provide sufficient space so appliance can be lifted over carpet.
Entire appliance does not operate	<ul style="list-style-type: none"> • Make sure power cord is plugged properly into outlet. • Electrical power outage. Check house lights to be sure. Call your local electric company for service outage information. • Service wiring is not complete. Call 1-800-4-MY-HOME® for assistance (see back cover).
Fan noise during cooking operation	<ul style="list-style-type: none"> • A cooling fan may automatically turn on and off to cool internal parts. • Some models are equipped with a cooling fan that runs during the cooking process to cool internal electronic components. It is normal for this fan to continue to run for an extended period of time, even when the oven is off.
Areas of discoloration with metallic sheen on cooktop surface	<ul style="list-style-type: none"> • Mineral deposits from water and food. Remove using the recommended CookTop® Cleaning Creme to the ceramic surface (on the web visit www.sears.com for replacement cooktop cleaner, item number 40079). Buff with a non-abrasive cloth or sponge

Master Protection Agreements

Congratulations on making a smart purchase. Your new Kenmore® product is designed and manufactured for years of dependable operation. But like all products, it may require preventive maintenance or repair from time to time. That's when having a Master Protection Agreement can save you money and aggravation.

The Master Protection Agreement also helps extend the life of your new product. Here's what the Agreement* includes:

- ☑ **Parts and labor** needed to help keep products operating properly **under normal use**, not just defects. Our coverage goes **well beyond the product warranty**. No deductibles, no functional failure excluded from coverage – **real protection**.
- ☑ **Expert service** by a force of more than **10,000 authorized Sears service technicians**, which means someone you can trust will be working on your product.
- ☑ **Unlimited service calls and nationwide service**, as often as you want us, whenever you want us.
- ☑ **“No-lemon” guarantee** – replacement of your covered product if four or more product failures occur within twelve months.
- ☑ **Product replacement** if your covered product can't be fixed.
- ☑ **Annual Preventive Maintenance Check** at your request – no extra charge.
- ☑ **Fast help by phone** – we call it **Rapid Resolution** – phone support from a Sears representative on all products. Think of us as a “talking owner's manual”.
- ☑ **Power surge protection** against electrical damage due to power fluctuations.
- ☑ **\$250 Food Loss Protection** annually for any food spoilage that is the result of mechanical failure of any covered refrigerator or freezer.
- ☑ **Rental reimbursement** if repair of your covered product takes longer than promised.
- ☑ **25% discount** off the regular price of any non-covered repair service and related installed parts.

Once you purchase the Agreement, a simple phone call is all that it takes for you to schedule service. You can call anytime day or night, or schedule a service appointment online.

The Master Protection Agreement is a risk free purchase. If you cancel for any reason during the product warranty period, we will provide a full refund. Or, a prorated refund anytime after the product warranty period expires. Purchase your Master Protection Agreement today!

Some limitations and exclusions apply. For prices and additional information in the U.S.A. call 1-800-827-6655.

*** Coverage in Canada varies on some items. For full details call Sears Canada at 1-800-361-6665.**

Sears Installation Service

For Sears professional installation of home appliances, garage door openers, water heaters, and other major home items, in the U.S.A. or Canada call **1-800-4-MY-HOME®**.

Acuerdos maestros de protección

Enhorabuena por haber hecho una compra inteligente. Su nuevo producto Kenmore® está diseñado y fabricado para brindarle años de funcionamiento fiable. Pero, como cualquier producto, puede necesitar mantenimiento preventivo o reparaciones periódicas. Es por eso que tener un Acuerdo maestro de protección podría ahorrarle dinero y molestias.

El Acuerdo maestro de protección también sirve para prolongar la durabilidad de su nuevo producto. El acuerdo* incluye lo siguiente:

- ☑ **Piezas y mano de obra** necesarias para contribuir a mantener el funcionamiento adecuado de los productos **utilizados en condiciones normales de uso**, no sólo en caso de defectos de los productos. Nuestra cobertura va **mucho más allá que la garantía del producto**. No se aplican deducibles ni exclusiones por fallas del funcionamiento: es decir, **verdadera protección**.
- ☑ **Servicio técnico por expertos** (más de **10000 técnicos autorizados de Sears**), lo cual significa que quien repare o realice el mantenimiento de su producto será un profesional de confianza.
- ☑ **Servicio técnico a escala nacional y número ilimitado de llamadas de solicitud de servicio técnico**: se puede poner en contacto con nosotros cuantas veces lo desee y cuando lo desee.
- ☑ **Garantía “sin sorpresas”**: se reemplaza el producto cubierto por el acuerdo si ocurren cuatro o más fallas del producto en un periodo de 12 meses.
- ☑ **Reemplazo del producto**: en caso de que no se pueda reparar el producto cubierto por el acuerdo.
- ☑ **Revisión anual preventiva de mantenimiento del producto**: puede solicitarla en cualquier momento, sin costo alguno.
- ☑ **Rápida asistencia telefónica**, la cual denominamos **Solución rápida**: es decir, asistencia telefónica a través de cualquiera de nuestros representantes de Sears, sobre cualquiera de nuestros productos. Piense en nosotros como en un “manual parlante del usuario”.
- ☑ **Protección contra fallas eléctricas**, contra daños debidos a fluctuaciones de la corriente eléctrica.
- ☑ **\$250 al año para cubrir cualquier posible deterioro de alimentos** que haya tenido que desechar debido a una falla mecánica de cualquiera de nuestros refrigeradores o congeladores cubiertos por este acuerdo.
- ☑ **Devolución de gastos de alquiler de electrodomésticos** si la reparación de su producto asegurado toma más que el tiempo prometido.
- ☑ **25% de descuento** aplicable tanto a los costos del servicio de reparación, como de las piezas instaladas relacionadas que no hayan quedado cubiertos por este acuerdo.

Una vez que haya realizado el pago de este acuerdo, bastará una simple llamada telefónica para concertar una visita de servicio. Puede llamar a cualquier hora del día o de la noche, o bien concertar una visita de servicio por Internet.

La adquisición del Acuerdo maestro de protección es una inversión exenta de riesgos. Si por cualquier motivo decide cancelar dicho acuerdo durante el periodo de garantía del producto, le haremos un reintegro total del valor. O bien un importe proporcional si cancela el acuerdo en cualquier otro momento posterior al vencimiento del periodo de garantía del producto. ¡Adquiera hoy mismo su Acuerdo maestro de protección!

Algunas limitaciones y exclusiones podrían aplicarse. Para solicitar precios e información adicional, llame al 1-800-827-6655 (en los EE.UU.).

*** La cobertura en Canadá varía en el caso de algunos artículos. Para obtener detalles completos al respecto, llame al 1-800-361-6665 de Sears de Canadá.**

Servicio de instalación de Sears

Para solicitar la instalación por profesionales de Sears de electrodomésticos, abridores de puertas de garaje, calentadores de agua y otros artículos de uso prioritario en el hogar, **llame al 1-800-4-MY-HOME** en los EE.UU. o Canadá.

Get it fixed, at your home or ours!

Your Home

For troubleshooting, product manuals and expert advice:



www.managemylife.com

For repair – **in your home** – of **all** major brand appliances, lawn and garden equipment, or heating and cooling systems, **no matter who made it, no matter who sold it!**

For the replacement parts, accessories and owner's manuals that you need to do-it-yourself.

For Sears professional installation of home appliances and items like garage door openers and water heaters.

1-800-4-MY-HOME[®] (1-800-469-4663)

Call anytime, day or night (U.S.A. and Canada)

www.sears.com www.sears.ca

Our Home

For repair of carry-in items like vacuums, lawn equipment, and electronics, call anytime for the location of your nearest

Sears Parts & Repair Service Center

1-800-488-1222 (U.S.A.)

www.sears.com

1-800-469-4663 (Canada)

www.sears.ca

To purchase a protection agreement on a product serviced by Sears:

1-800-827-6655 (U.S.A.)

1-800-361-6665 (Canada)

Para pedir servicio de reparación a domicilio, y para ordenar piezas:

1-888-SU-HOGAR[®]

(1-888-784-6427)

www.sears.com

Au Canada pour service en français:

1-800-LE-FOYER^{MC}

(1-800-533-6937)

www.sears.ca

sears

® Registered Trademark / TM Trademark of KCD IP, LLC in the United States, or Sears Brands, LLC in other countries

® Marca Registrada / TM Marca de Fábrica de KCD IP, LLC en Estados Unidos, o Sears Brands, LLC in otros países

^{MC} Marque de commerce / ^{MD} Marque déposée de Sears Brands, LLC