

USE THESE INSTRUCTIONS FOR MONOGRAM SINGLE-DOOR UNITS ONLY

Installation Instructions

Single Door Drain Pan Kit (WR74X10355)

MODELS: ZIF*360NX* AND ZIR*360NX*

Questions? Call 1-800-GE-CARES (1-800-432-7237)

PARTS PROVIDED:

Single Door Drain Pan Kit (WR74X10355)

- Drain Pan Assembly
- Baffle Template
- Evaporator Cover Assembly
- #10 Self-tapping Screw
- 10 Watt Heater
- Harness



TOOLS REQUIRED:

- #2 Phillips Screwdriver with 6" Extension for Screwdriver and 1/4 Head-head attachment
- RTV 102
- Flat-head Screwdriver
- Scraper

PPE REQUIRED:

- Safety Goggles
- Safety Gloves
- Padding/Support for knees

IMPORTANT SAFETY NOTICE:

This kit is to be installed by a qualified service technician only. Any attempt to repair a major appliance may result in personal injury and property damage. Failure to follow these installation instructions can result in personal injury or property damage.

WARNING DISCONNECT POWER TO THE REFRIGERATOR BEFORE BEGINNING INSTALLATION

STOP BEFORE YOU BEGIN
Read these instructions completely and carefully.

WARNING
Disconnect power to the appliance before beginning installation. Do not operate the refrigerator until the installation is complete.

WARNING
This refrigerator is top heavy and must be handled with care. Failure to do so can result in the unit tipping over and result in death or serious injury. Before beginning service, ensure that the anti-tip bracket is correctly installed.

PROCEDURE:

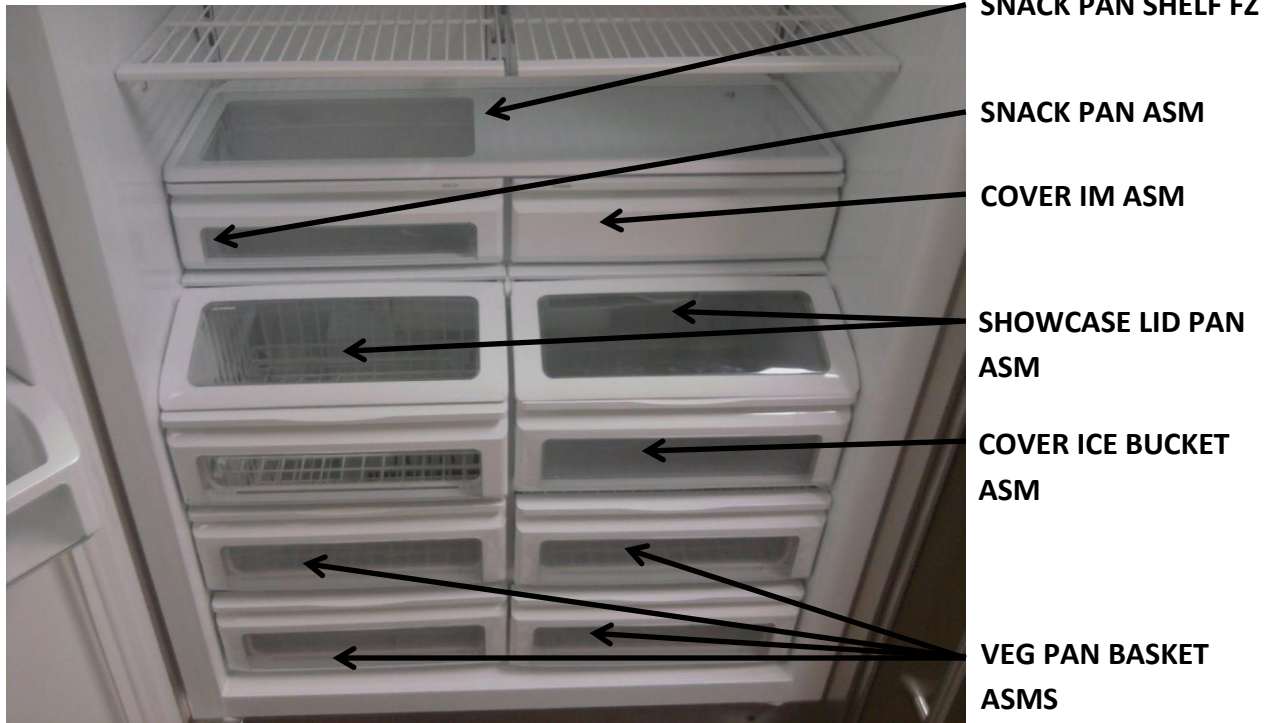

Picture 1

1. Unplug the unit.
2. Remove SNACK PAN SHELF FZ {WR17X12679}. (See PICTURE 1)
3. Pull out, disengage clips, and pull off of the slide rail to remove COVER IM ASM {WR32X10804}.

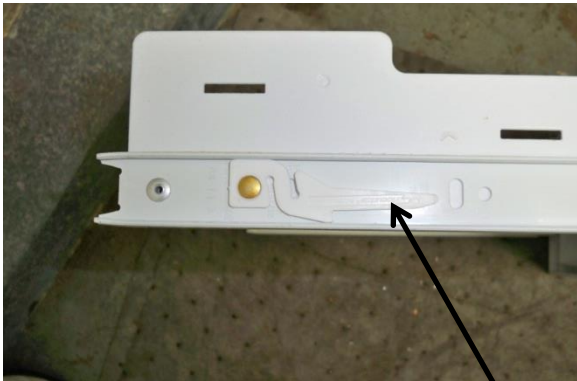

Left Side Clip is pushed upward.

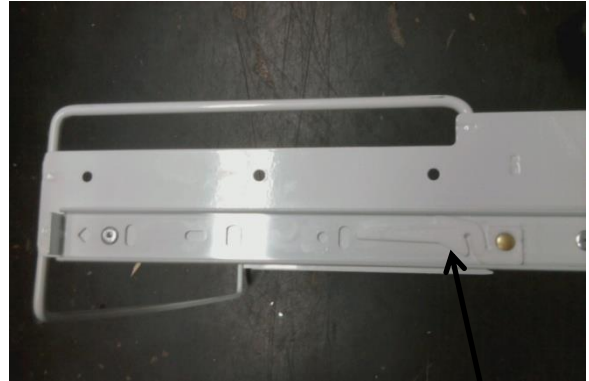

Right Side Clip is pushed downward.

4. Pull out and upward to remove SNACK PAN ASM {WR32X10078}. (See Picture 1)
5. Pull out, disengage clips (Refer to Picture under Step 3), and pull off of the slide rail to remove SUPPORT SNACK PAN ASM {WR72X10325}.



**SUPPORT SNACK PAN
ASM**

6. Pull out to remove two STRIP SD FZ VEG PAN {WR02X13223}.

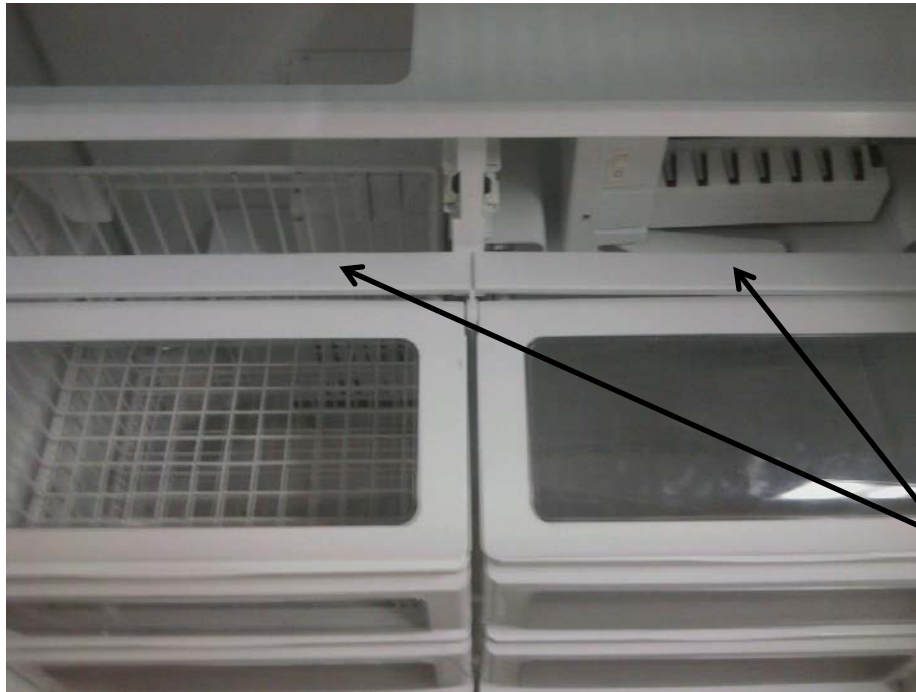

STRIP SD FZ VEG PAN

7. Remove screw and WASHER SHOWCASE PIVOT {WR01X10046} (these will be put back) from side nearest unit wall to allow SHOWCASE LID PAN ASM {WR32X10720} to be removed from bushing.

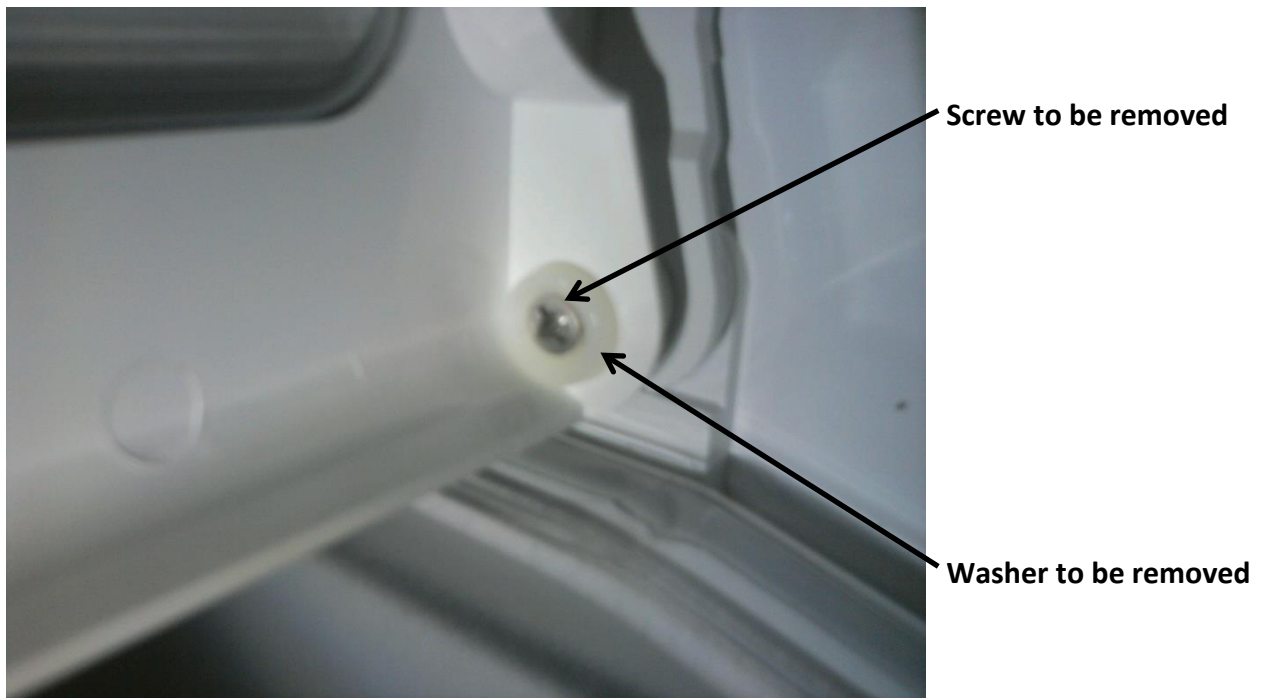

8. Push inwards at sides in back and dislodge from bushing (if bushing falls, put it back on the wall of the cabinet) to remove Left {WR32X10119} and Right SHOWCASE LID PAN ASM {WR32X10720}. (See PICTURE 1)
9. Pull out and upward to remove COVER ICE BUCKET ASM {WR32X10728}. (See PICTURE 1)
10. Pull out and upward to remove VEG PAN WIRE ASM {WR21X10209}.
11. Pull out, disengage clips (Refer to Picture under Note 2), and pull off of the slide rail to remove Left {WR72X10324} and Right SUPPORT BASKET ASM {WR72X10323}.

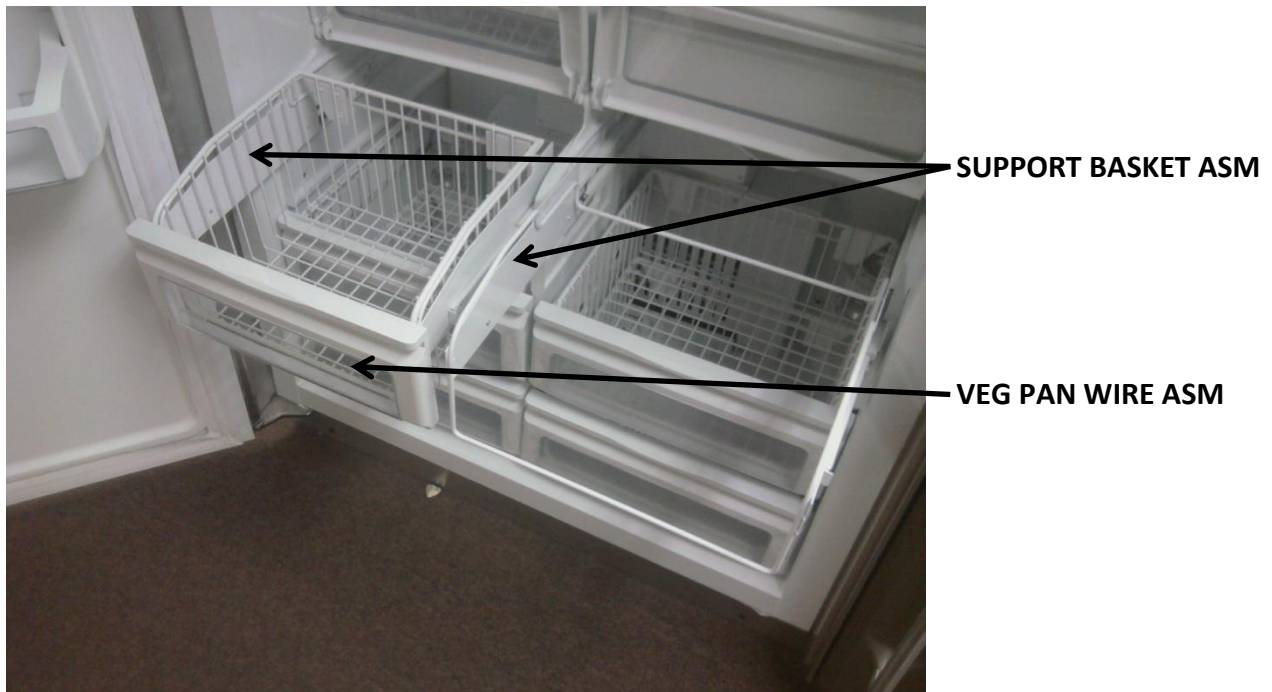

12. Pull out and upward to remove four VEG PAN BASKET ASM {WR32X10121}.
13. Pull out, disengage clips (Refer to Picture under Note 2), and pull off of the slide rail to remove four SUPPORT VEG BASKET ASM {WR72X10200}. (See PICTURE 1)



**SUPPORT VEG BASKET
ASM**

14. Remove two 8-32 X 5/8" PH SS TCS SCREWS {WR01X10484} holding the ice maker. (Freezer only)
15. Unplug the icemaker. (Freezer only)

NOTE: Flathead screwdriver may be needed to disengage clips.



Unplug icemaker here

Screws to be removed

16. Remove icemaker assembly and set it aside. (Freezer only)
17. Remove eight #10-16 X 1/2 TAPPING SCREWS holding the center divider assembly. (These will be reused)
18. Pull out to remove DIVIDER CENTER ASM {WR72X10320}.



19. Use screw driver to remove seven SELF DRILL TRIM P SCREWS holding the evaporator cover. Save fasteners for reuse.
20. Remove EVAP COVER ASM {WR74X10355} and discard.

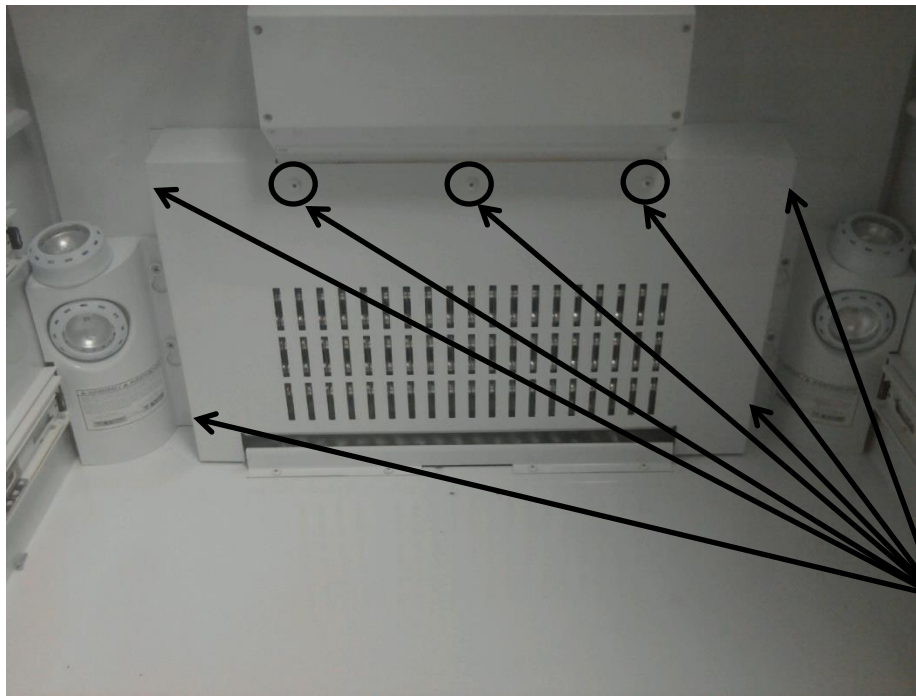

Screws to be removed

21. Unplug 9-pin connector of HARNESS HEATERS TOD {WR09X10180} from back wall of the unit.
NOTE: Flathead screwdriver may be needed to disengage clips.
22. Unplug Defrost heater {WR51X10113} from the HARNESS HEATERS TOD {WR09X10180}.
23. Unclip thermodisc and remove HARNESS HEATERS TOD {WR09X10180} (Harness can be discarded).

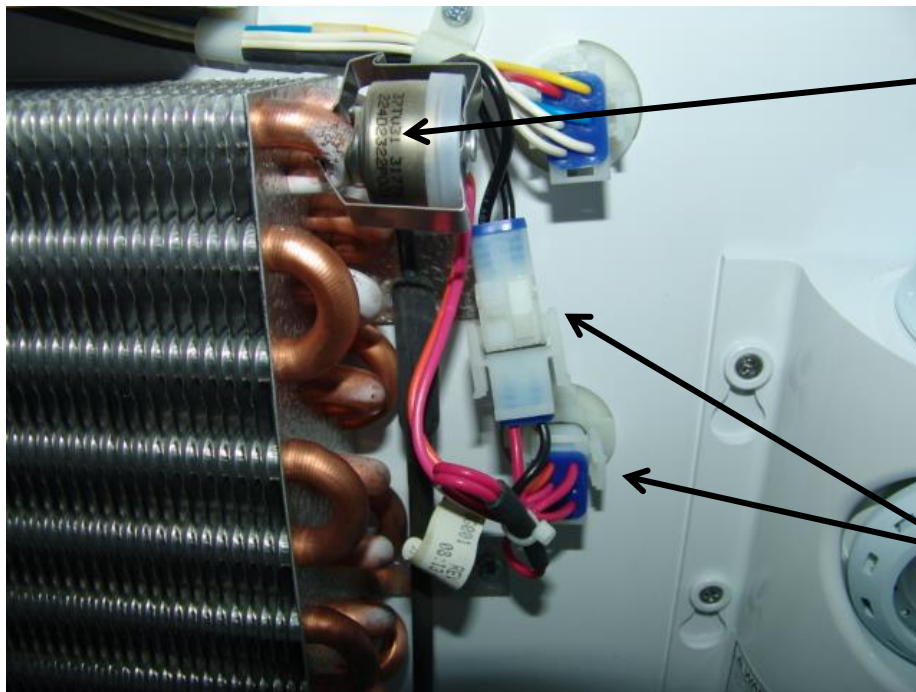

Unclip thermodisc and remove.

Unplug these harness connections

24. Use driver to remove four SELF DRILL TRIM P SCREWS holding the catch evaporator trough.
 Save fasteners for reuse.

25. Remove CATCH EVAPORATOR TROUGH {WR17X12711}. (This will be put back later)

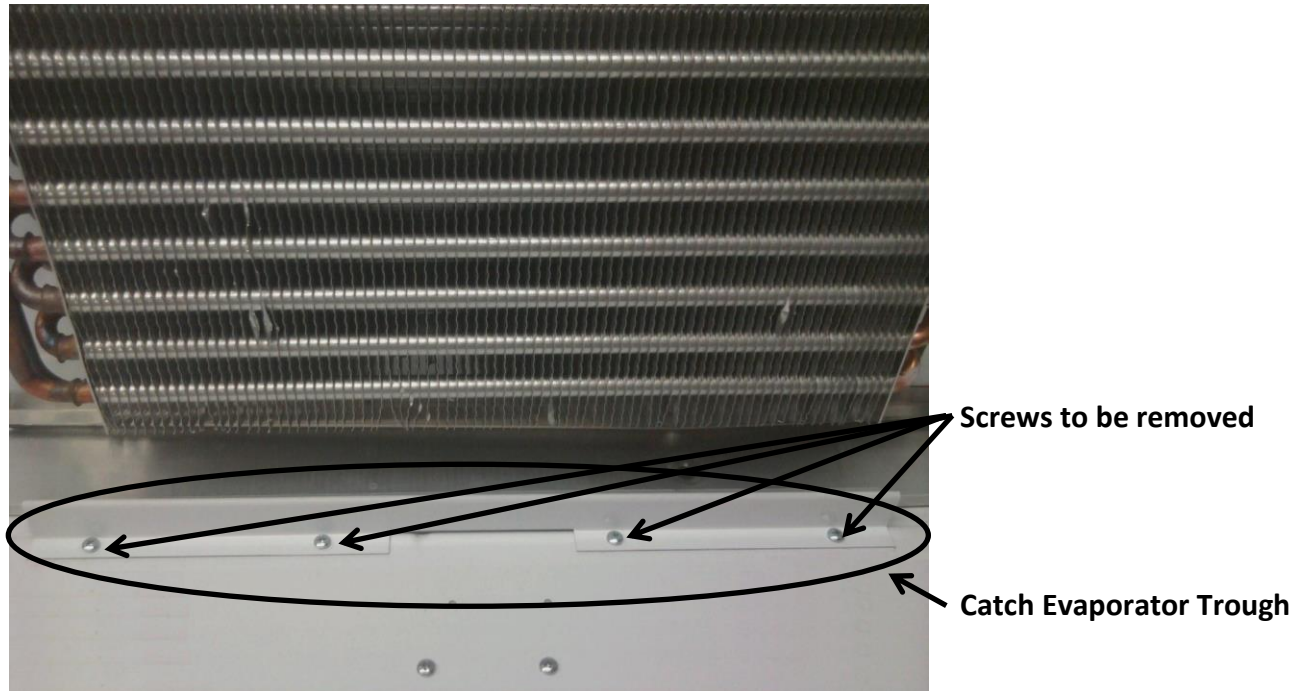

26. Use driver to remove four #10X1\2 PH SMS SCREWS {WD02X0295} holding the Evaporator in place.

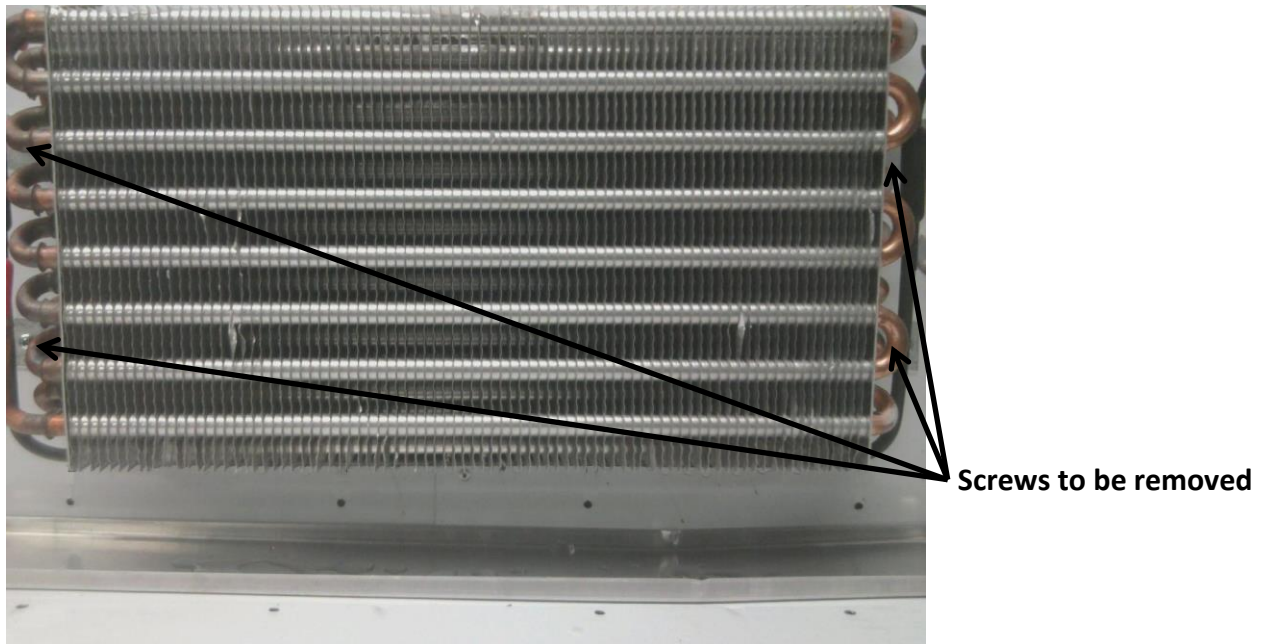

27. Pull Evaporator forward slightly to work behind it.

28. Use driver to remove four TRIM (SELF TAPPING) SCREWS holding the drain baffle in place.

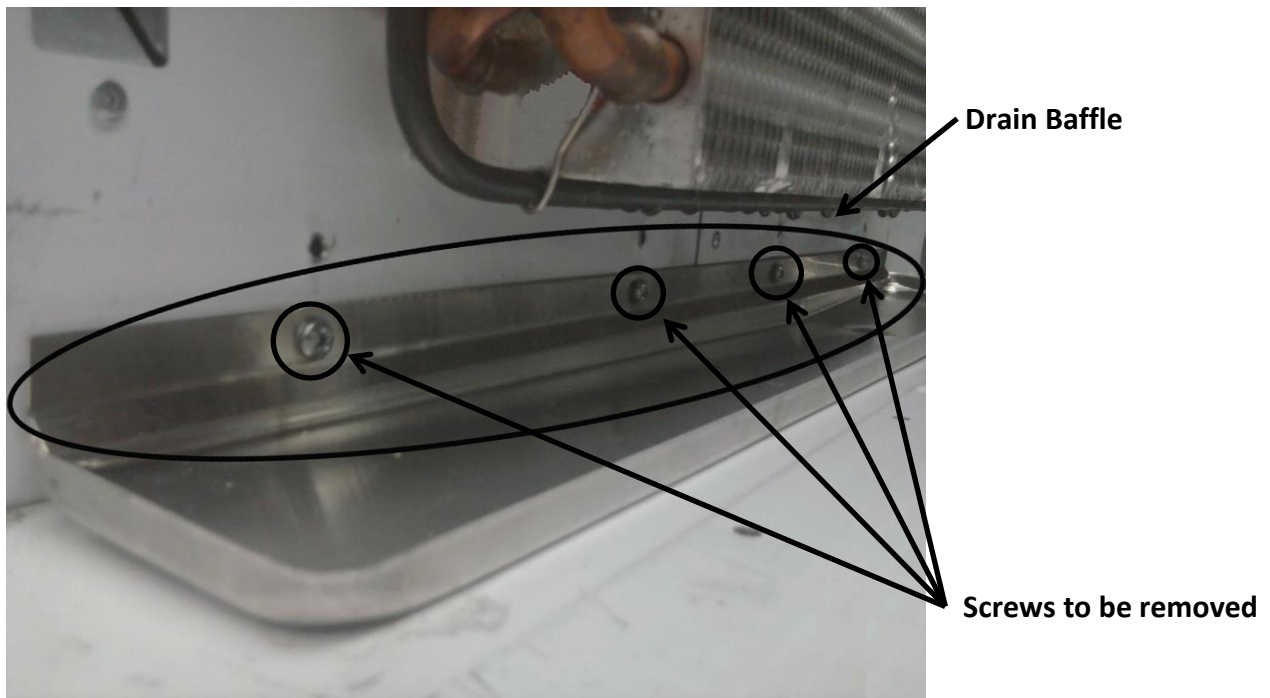

29. Use scraper to separate the gasket of the drain baffle from the back wall of the unit.

30. Remove DRAIN BAFFLE {WR17X12683}.

NOTE: Remove any pieces of the gasket that tear and stick to the back wall of the unit

31. Remove DRAIN PAN {WR17X11016}.



32. Use the TRIM (SELF TAPPING) SCREWS to screw the baffle template in place using the four lower holes.

NOTE: Wait until all four screws have been started before tightening them.

33. Use hex-head attachment to drive the four #10 Screws in the 4 upper holes.

NOTE: Wait until all four screws have been started before tightening them.

34. Remove the TRIM (SELF TAPPING) SCREWS from the baffle template.

35. Discard the baffle template.

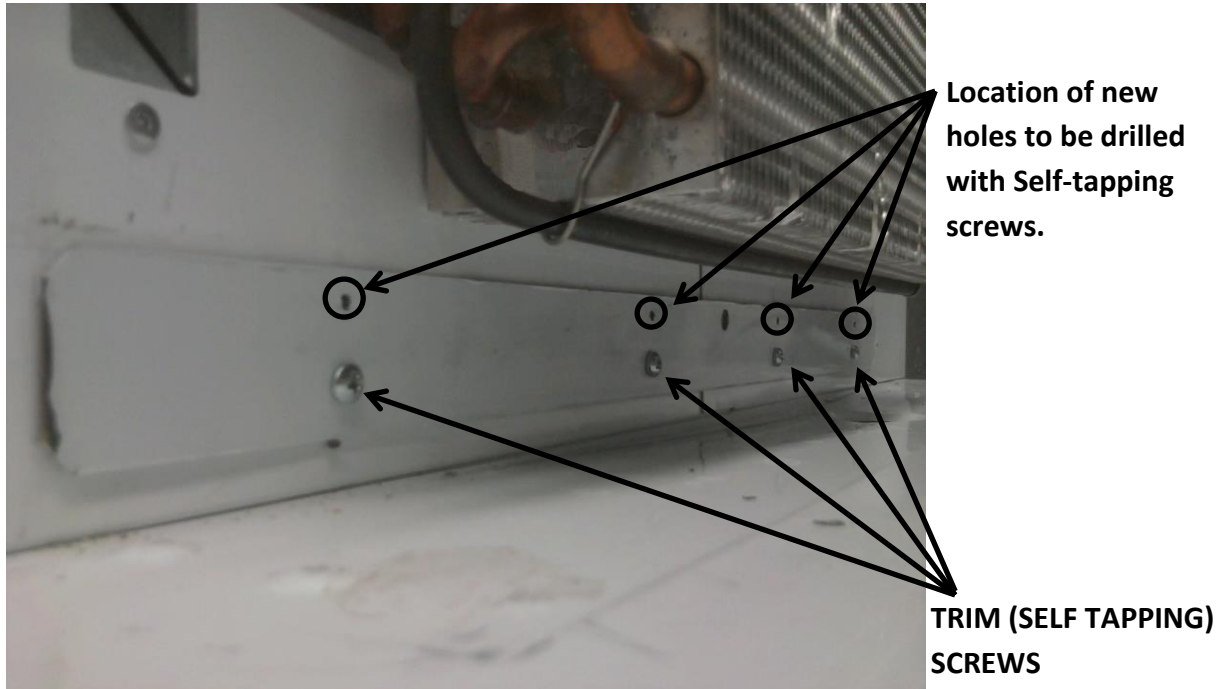

36. Use electric driver to put holes in the gasket corresponding to the screw holes of the new drain pan.



37. Peel right side of tape on new drain pan to just past the farthest hole on the right side.



38. Insert spout of new drain pan into drain of unit.

39. **CAUTION: Ensure the spout on drainpan is not impacted and loosened during installation. Do not force.**



40. Use the driver to start a TRIM (SELF TAPPING) SCREW {WR01X10188} through the farthest right hole of the drain pan and into the farthest right hole that was just drilled into the back wall of the unit.

NOTE: Do not tighten fully.

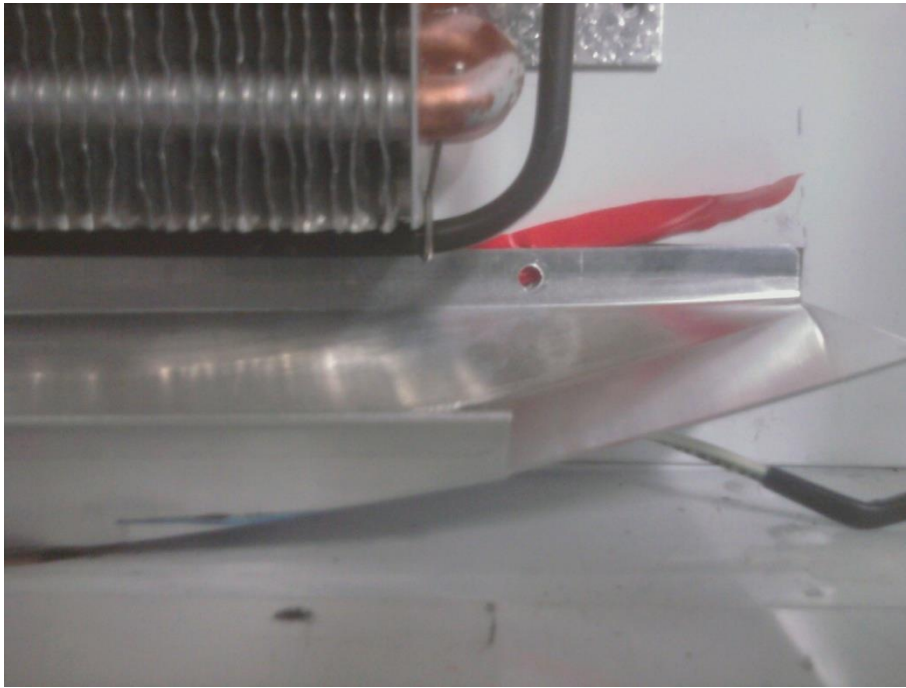

41. Peel the tape further until it is past the next hole on the drain pan and screw into place.

NOTE: Do not tighten fully (Repeat for the remaining screw holes.)

NOTE: Do not bend EVAPORATOR FINS.

42. Wait until all four screws have been started before tightening them.



43. Apply a small amount of RTV along the top edge of the drain pan where it meets the back wall of the cabinet.

CAUTION: Do not get RTV on the EVAPORATOR FINS to prevent improper operation.

CAUTION: DO NOT GET RTV ON THE DEFROST HEATER to prevent malfunction.



44. Screw the Evaporator back into place with the four #10X1\2 PH SMS SCREWS {WD02X0295}.
45. Clip thermodisc on new HARNESS HEATERS TOD into place.
46. Connect the 9-pin connector on new HARNESS HEATERS TOD.
47. Plug Defrost heater and drain pan heater into new HARNESS HEATERS TOD.

NOTE: Drain pan heater wires should come over the side of the pan.

NOTE: See picture 2

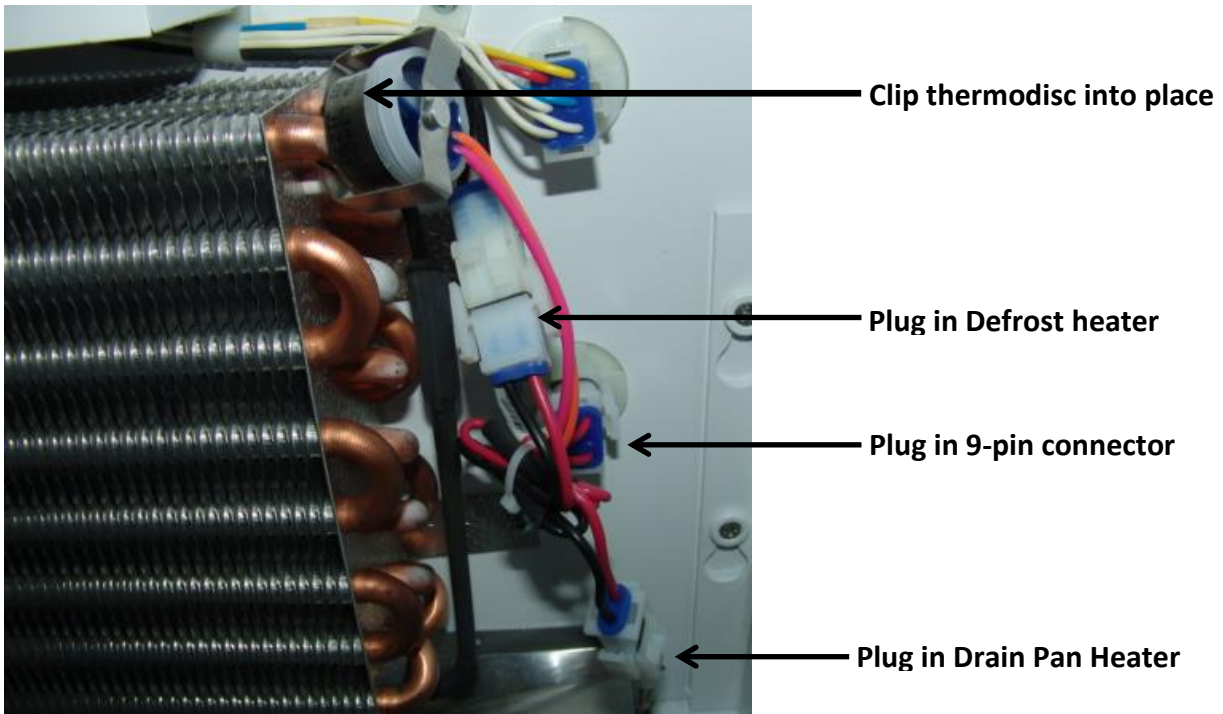

Picture 2

48. Screw the CATCH EVAPORATOR TROUGH {WR17X12711} back into place with the four SELF DRILL TRIM P SCREWS.

NOTE: Slide under new evaporator trough instead of over).



**SLIDES
UNDERNEATH
THE DRAIN PAN**

CAUTION: DO NOT BEND OR CHANGE THE GEOMETRY OF THE DRAIN PAN to prevent malfunction.

49. Take new evaporator cover and screw into place with seven SELF DRILL TRIM P SCREWS.



- 50. Replace DIVIDER CENTER ASM {WR72X10320}.
- 51. Screw back into place using eight #10-16 X 1/2 TAPPING SCREWS.
- 52. Replace icemaker assembly. (Freezer only)
- 53. Screw back into place using two 8-32 X 5/8" PH SS TCS SCREWS {WR01X10484}. (Freezer only)
- 54. Plug in icemaker. (Freezer only)

NOTE: Be sure that icemaker switch is turned "On".

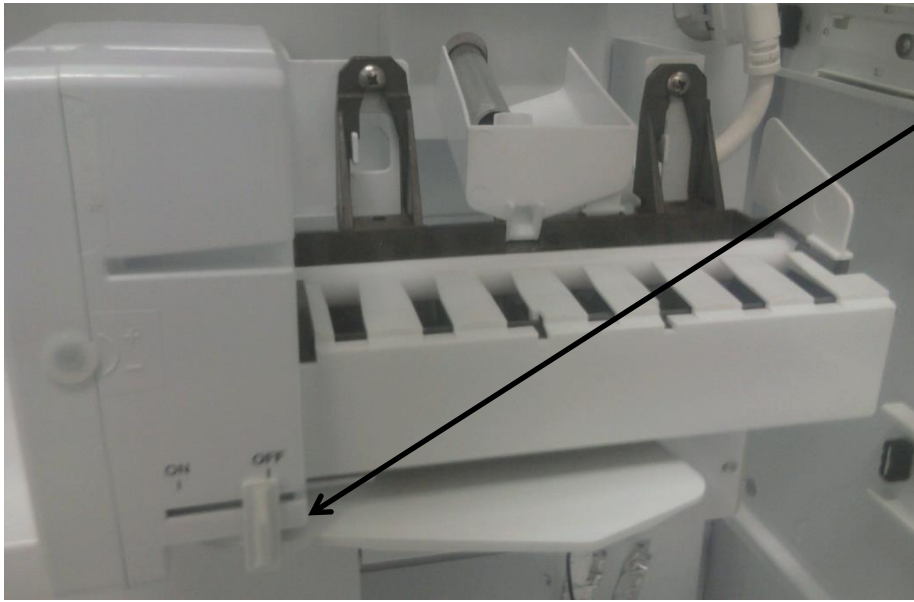

Turn switch from the
"OFF" to "ON"
position.

- 55. Replace drawers and baskets.
- 56. Plug in unit.

NOTE: WHILE PERFORMING INSTALLATIONS DESCRIBED IN THIS BOOK, SAFETY GLASSES OR GOGGLES SHOULD BE WORN. FOR MONOGRAM® LOCAL SERVICE IN YOUR AREA, CALL 1.800.444.1845.

NOTE: PRODUCT IMPROVEMENT IS A CONTINUING ENDEAVOR AT GENERAL ELECTRIC. THEREFORE, MATERIALS, APPEARANCE AND SPECIFICATIONS ARE SUBJECT TO CHANGE WITHOUT NOTICE

Part. No. **WR74X10355**
Pub. No. **31-49005**
GE 2012



GE Appliances & Lighting
General Electric Company
Louisville, KY 40225
GEAppliances.com

Universal Keywords: Div46 Src363 GE General Electric Mechttech

Document Specific Keywords: Instruction Sheet

Date: 101116

Document Name: 31-49005

Subject: GE Monogram Refrigerator/Freezer Single Door Drain Pan Kit Instructions

Models: ZIR360NXALH ZIR360NXARH ZIRS360NXALH ZIRS360NXARH

ZIRP360NXALH ZIRP360NXARH ZIF360NXALH ZIF360NXARH ZIFS360NXALH

ZIFS360NXARH ZIFP360NXALH ZIFP360NXARH REF0413