

WEIDER[®] PRO 7500

Model No. 831.15968.0

Serial No. _____

Write the serial number in the space above for reference.

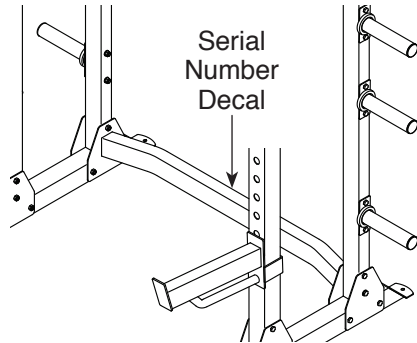

WEIGHT RACK EXERCISER User's Manual

- Assembly
- Operation
- Maintenance
- Part List and Drawing

Sears, Roebuck and Co.
Hoffman Estates, IL 60179

CAUTION

Read all precautions and instructions in this manual before using this equipment. Keep this manual for future reference.

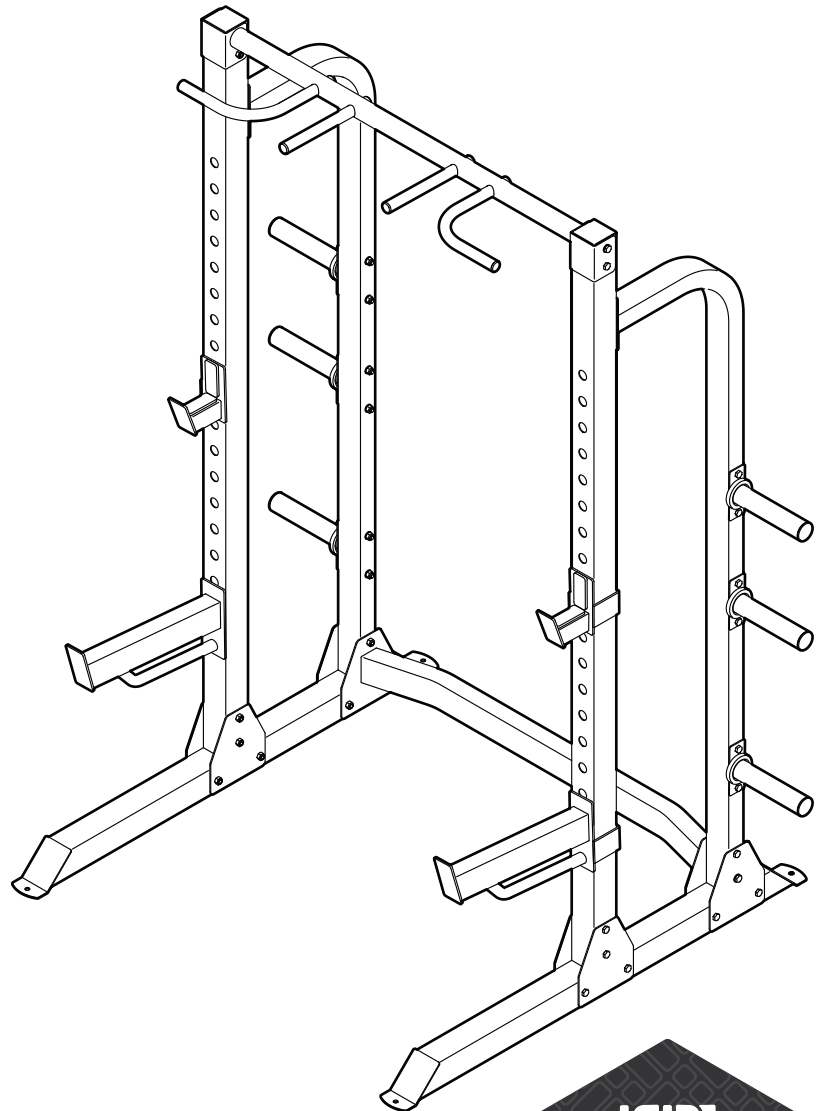
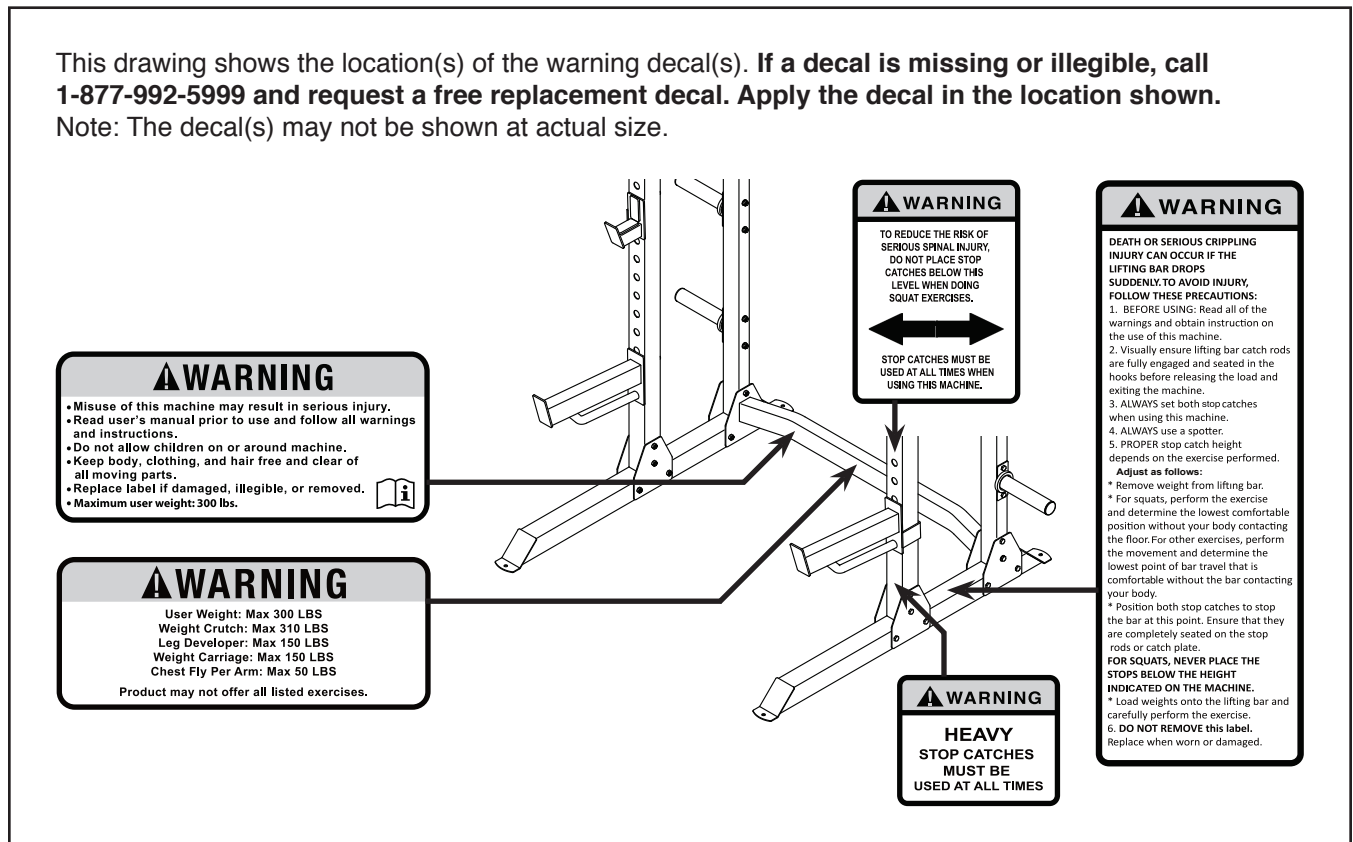

TABLE OF CONTENTS

WARNING DECAL PLACEMENT	2
IMPORTANT PRECAUTIONS	3
BEFORE YOU BEGIN	4
PART IDENTIFICATION CHART	5
ASSEMBLY	6
ADJUSTMENT	10
EXERCISE GUIDELINES	11
PART LIST	14
EXPLODED DRAWING	15
ORDERING REPLACEMENT PARTS	Back Cover
90 DAY FULL WARRANTY	Back Cover

WARNING DECAL PLACEMENT

This drawing shows the location(s) of the warning decal(s). **If a decal is missing or illegible, call 1-877-992-5999 and request a free replacement decal. Apply the decal in the location shown.**
 Note: The decal(s) may not be shown at actual size.



IMPORTANT PRECAUTIONS

⚠️ WARNING: To reduce the risk of serious injury, read all important precautions and instructions in this manual and all warnings on the weight rack before using the weight rack. Sears assumes no responsibility for personal injury or property damage sustained by or through the use of this product.

1. It is the responsibility of the owner to ensure that all users of the weight rack are adequately informed of all precautions
2. Before beginning any exercise program, consult your physician. This is especially important for persons over age 35 or persons with pre-existing health problems.
3. The weight rack is not intended for use by persons with reduced physical, sensory, or mental capabilities or lack of experience and knowledge, unless they are given supervision or instruction about use of the weight rack by someone responsible for their safety.
4. Use the weight rack only as described in this manual.
5. The weight rack is intended for home use only. Do not use the weight rack in any commercial, rental, or institutional setting.
6. Keep the weight rack indoors, away from moisture and dust. Do not put the weight rack in a garage or covered patio, or near water.
7. Place the weight rack on a level surface, with enough clearance around the weight rack to mount, dismount, and use the weight rack. To protect the floor or carpet from damage, place a mat under the weight rack.
8. Using the four anchor holes to provide maximum stability, the weight rack must be anchored to the floor where required or whenever possible.
9. Inspect and properly tighten all parts each time the weight rack is used. Replace any worn parts immediately.
10. Keep children under age 13 and pets away from the weight rack at all times.
11. Keep hands and feet away from moving parts.
12. Wear appropriate clothes while exercising; do not wear loose clothes that could become caught on the weight rack. Always wear athletic shoes for foot protection while using the weight rack.
13. The weight rack is designed to support a maximum user weight of 300 lbs. (136 kg), and a maximum total weight of 610 lbs. (277 kg). Do not use the weight bench with more than 310 lbs. (141 kg) of weight, including a barbell. The pull-up bar is designed to support a maximum user weight of 300 lbs. (136 kg). Note: The weight rack does not include weights or a barbell.
14. Always place both weight rests at the same height and both spotters at the same height. Make sure that there are at least three adjustment holes between the weight rests and the spotters.
15. Over exercising may result in serious injury or death. If you feel faint, if you become short of breath, or if you experience pain while exercising, stop immediately and cool down.

BEFORE YOU BEGIN

Thank you for selecting the WEIDER® PRO 7500 weight rack. The PRO 7500 is designed to help you develop the major muscle groups of your body. Whether your goal is to tone your body, build dramatic muscle size and strength, or improve your cardiovascular system, the weight rack will help you to achieve the specific results you want.

For your benefit, read this manual carefully before you use the weight rack. If you have questions after

reading this manual, please see the back cover of this manual. To help us assist you, note the product model number and serial number before contacting us. The model number and the location of the serial number decal are shown on the front cover of this manual.

Before reading further, please familiarize yourself with the parts that are labeled in the drawing below.

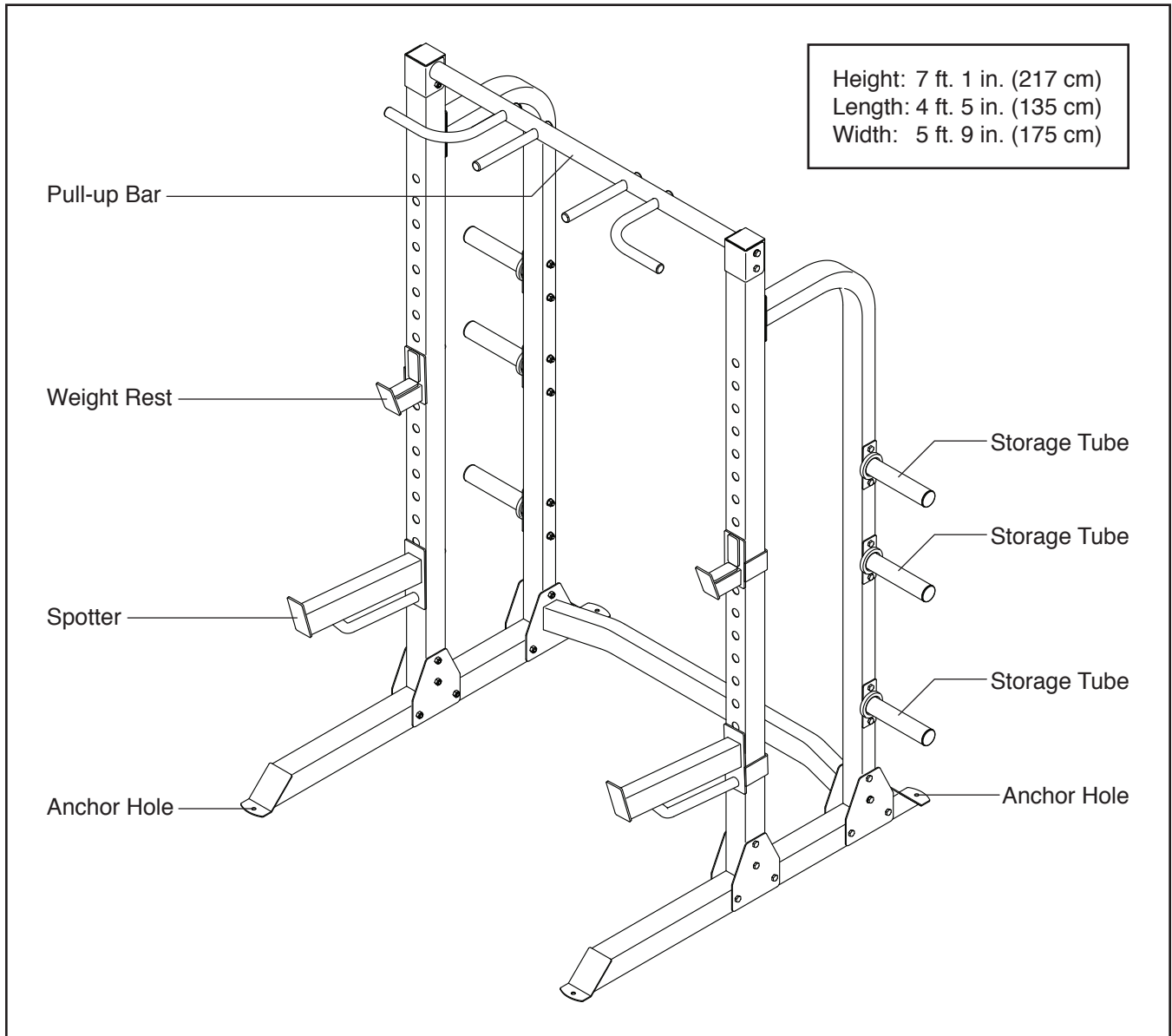

PART IDENTIFICATION CHART

Use the drawings below to identify the small parts needed for assembly. The number in parentheses below each drawing is the key number of the part, from the PART LIST near the end of this manual. **Note: If a part is not in the hardware kit, check to see whether it has been preassembled. Extra hardware may be included. If a part is missing, call 1-877-992-5999.**

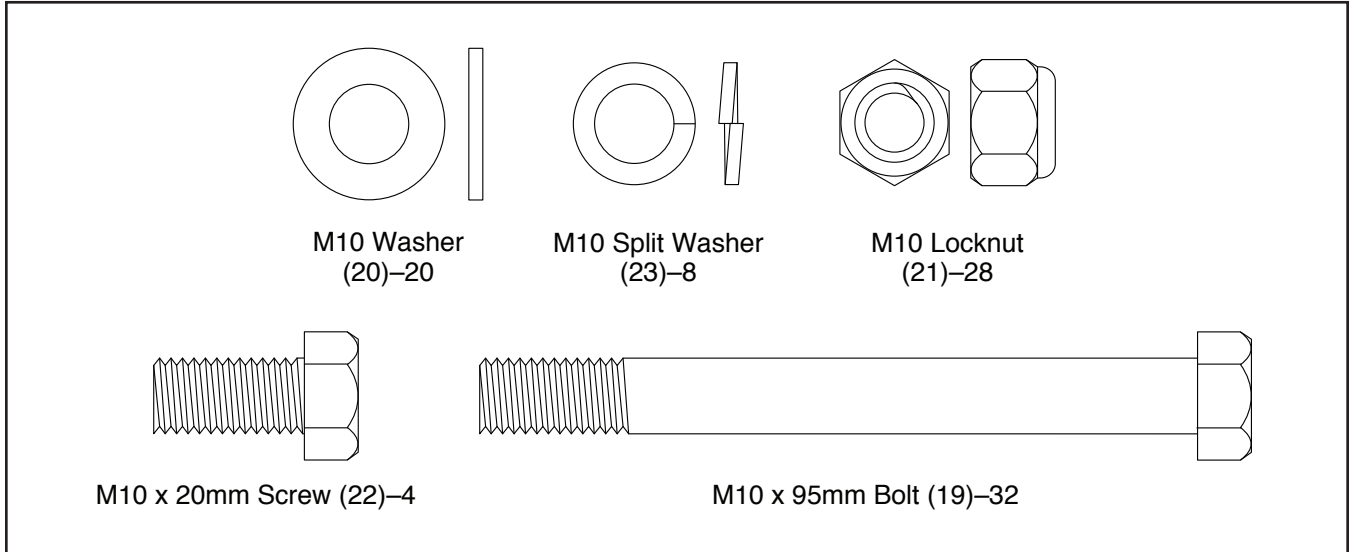

ASSEMBLY

- Assembly requires two persons.
 - Because of its weight and size, assemble the weight rack in the location where it will be used. Make sure that there is enough clearance to walk around the weight rack as you assemble it.
 - Place all parts in a cleared area and remove the packing materials. Do not dispose of the packing materials until you finish all assembly steps.
 - To identify small parts, see page 5.
 - Left parts are marked “L” or “Left” and right parts are marked “R” or “Right.”
 - In addition to the included tool(s), assembly requires the following tools:
two adjustable wrenches 
- Assembly may be easier if you have a set of wrenches. To avoid damaging parts, do not use power tools.

1. **Go to www.weiderservice.com/registration on your computer and register your product.**

- activates your warranty
- saves you time if you ever need to contact Customer Care
- allows us to notify you of upgrades and offers

Note: If you do not have internet access, call 1-877-992-5999 and register your product.

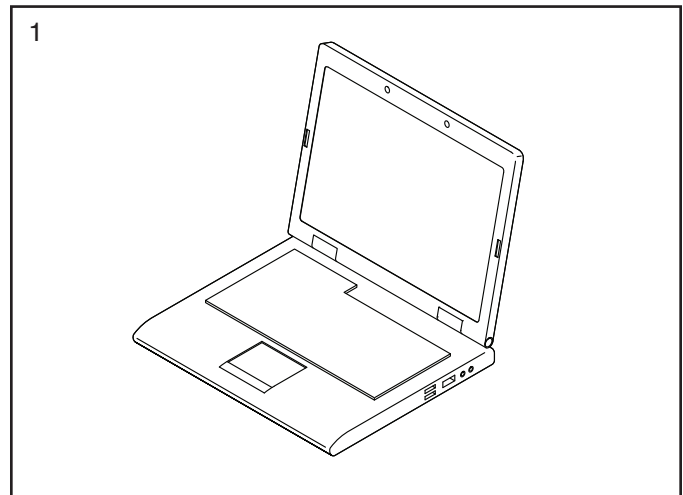

2. Identify the Crossbar (7) and the Right Base (1), and orient them as shown.

Attach the Right Base (1) to the Crossbar (7) with two M10 x 95mm Bolts (19), a Support Plate (13), and two M10 Locknuts (21); **do not fully tighten the Locknuts yet.**

Attach the Left Base (not shown) to the other end of the Crossbar (7) in the same way.

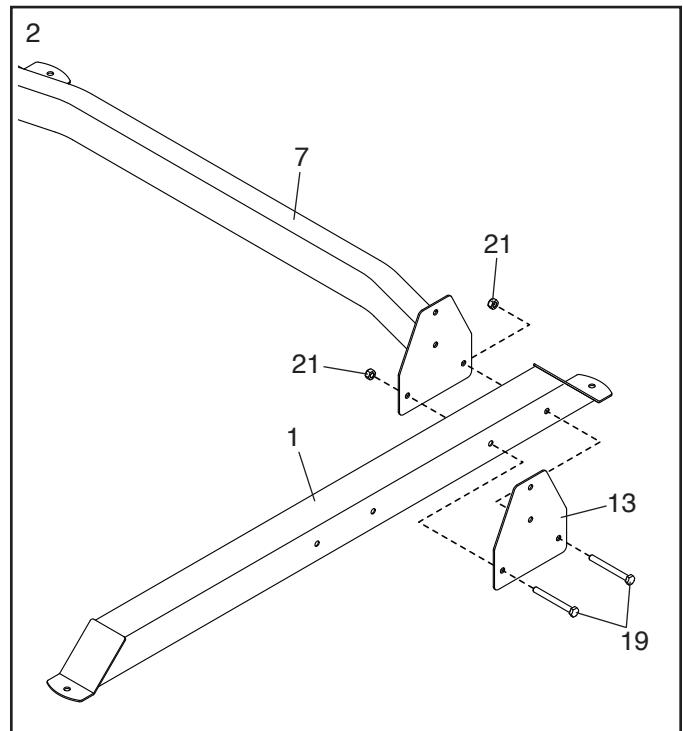

3. Identify the Right Rear Upright (5) and orient it as shown.

Attach the Right Rear Upright (5) to the Crossbar (7) and the Support Plate (13) with two M10 x 95mm Bolts (19), an M10 Split Washer (23), an M10 Washer (20), and an M10 Locknut (21); **do not fully tighten the Bolts yet.**

Attach the Left Rear Upright (not shown) to the other side of the weight rack in the same way.

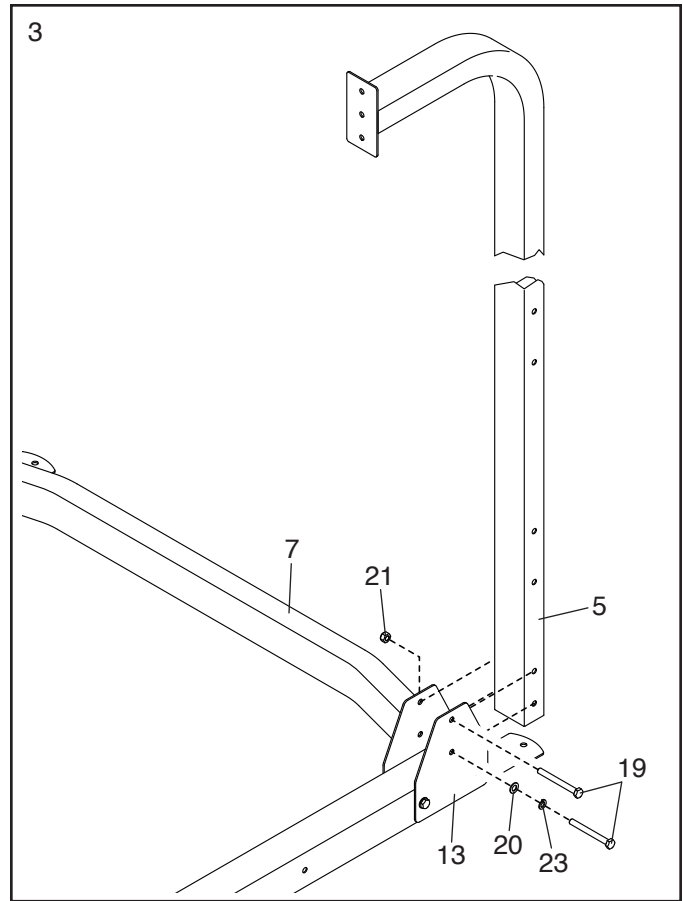

4. Identify the Right Front Upright (3) and orient it so that the indicated holes (A) are in the position shown.

Attach the Right Front Upright (3) to the Right Base (1) with four M10 x 95mm Bolts (19), two Support Plates (13), and four M10 Locknuts (21); **do not fully tighten the Locknuts yet.**

Attach the Left Front Upright (not shown) to the other side of the weight rack in the same way.

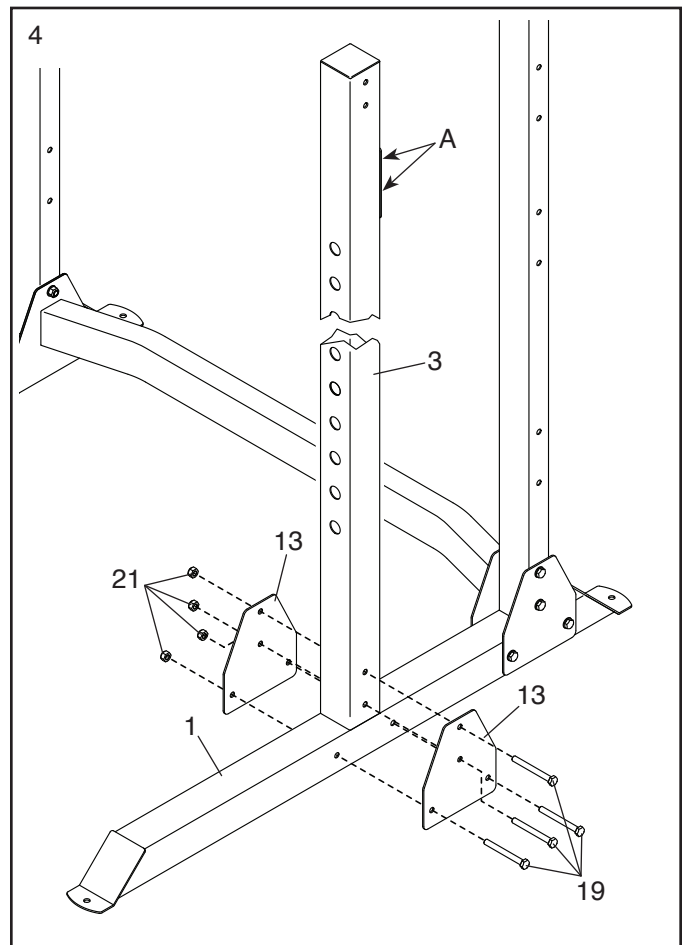

5. Attach the Right Rear Upright (5) to the Right Front Upright (3) with two M10 x 20mm Screws (22), two M10 Split Washers (23), and two M10 Washers (20); **do not fully tighten the Screws yet.**

Repeat this step on the other side of the weight rack.

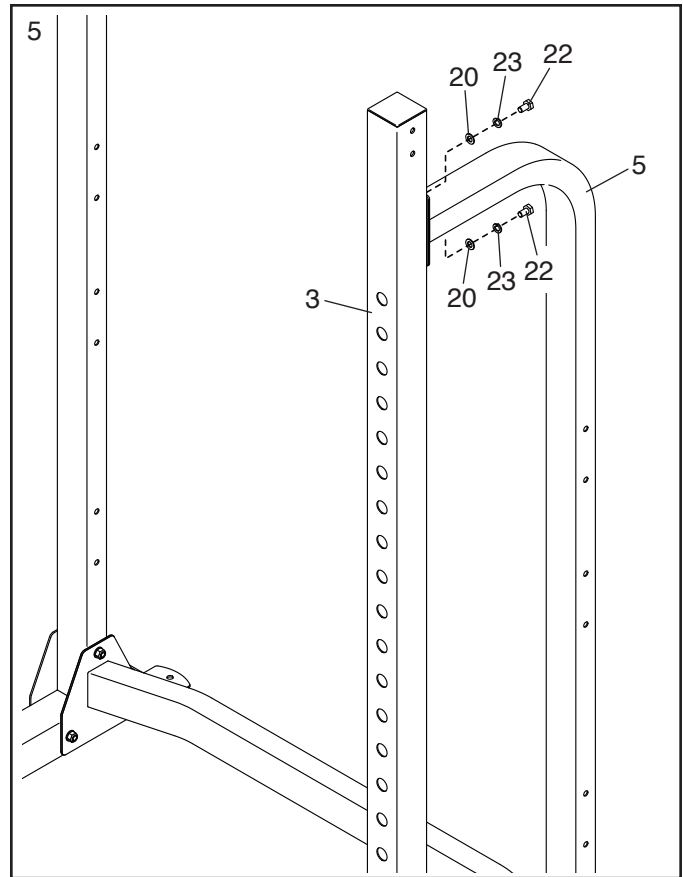

6. Identify the Pull-up Bar (8) and **orient it so that the long side of the bracket (B) is in the indicated location.**

Attach the Pull-up Bar (8) to the Right Front Upright (3) with two M10 x 95mm Bolts (19), an M10 Split Washer (23), an M10 Washer (20), and an M10 Locknut (21); **do not fully tighten the Bolts yet.**

Repeat this step on the other side of the weight rack.

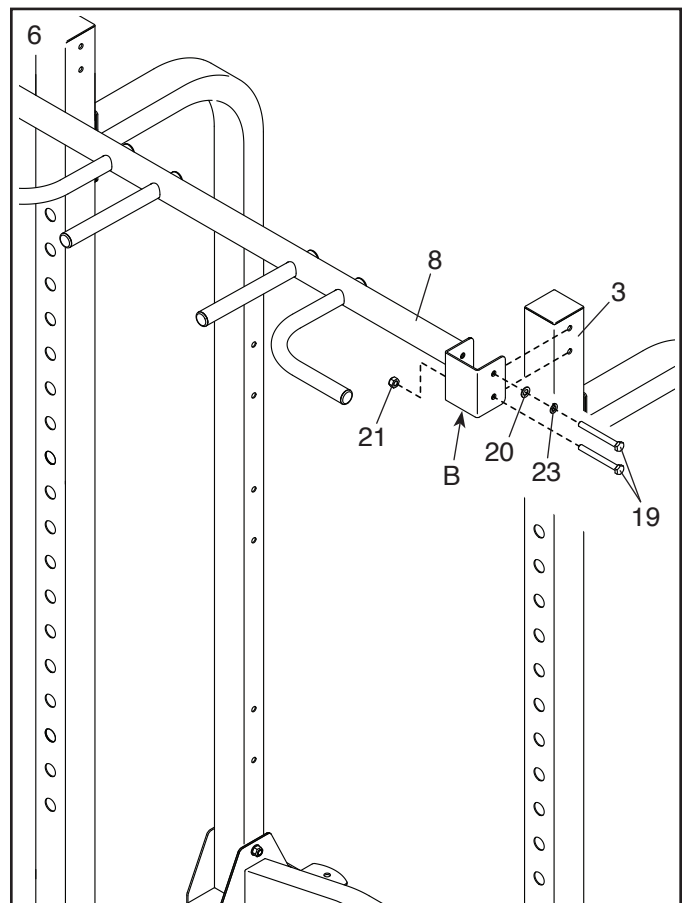

7. **See steps 2–6. Tighten all the M10 Locknuts (21), M10 x 95mm Bolts (19), and M10 x 20mm Screws (22).**

Next, attach a Storage Tube (14) to the Right Rear Upright (5) with two M10 x 95mm Bolts (19), two M10 Washers (20), and two M10 Locknuts (21).

Then, slide a Bumper (16) onto the Storage Tube (14).

Attach two more Storage Tubes (14) to the Right Rear Upright (5) in the same way.

Repeat this step on the other side of the weight rack.

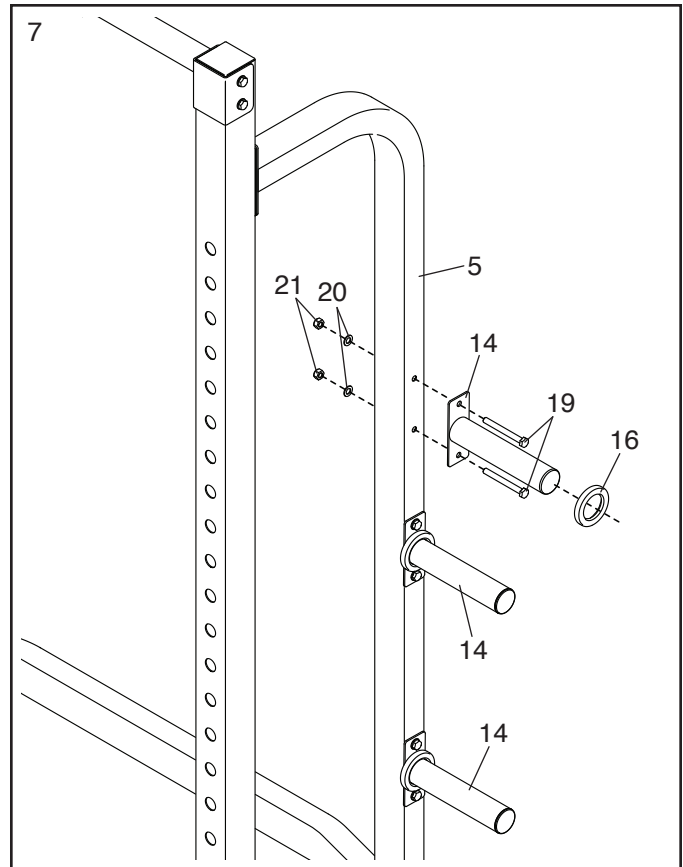

8. Insert the Right Weight Rest (9) into the desired adjustment hole in the Right Front Upright (3). Then, insert the Right Spotter (11) into an adjustment hole below the Right Weight Rest.

Repeat this step on the other side of the weight rack.

Make sure to insert both Weight Rests (9, 10 [not shown]) and both Spotters (11, 12 [not shown]) at the same height.

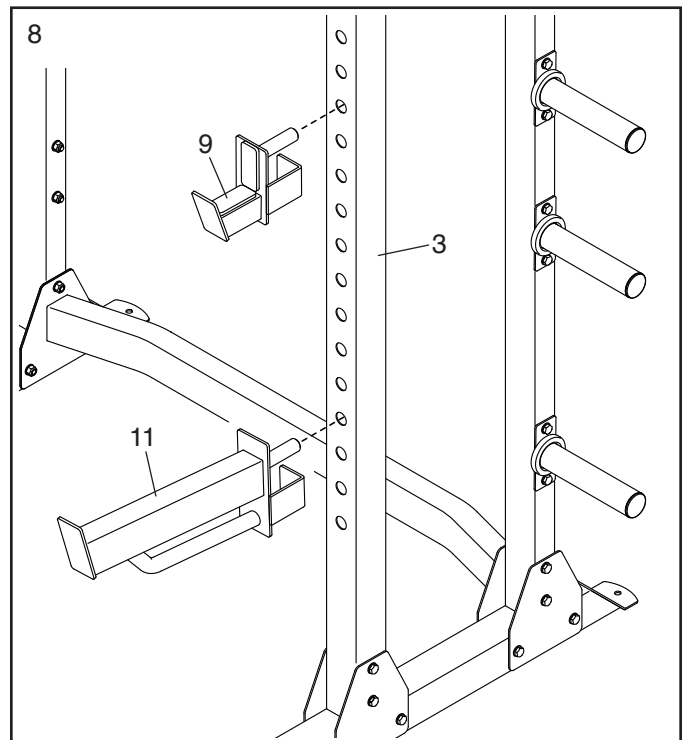

9. **Make sure that all parts of the weight rack are properly tightened.** Extra parts may be included. Place a mat under the weight rack to protect the floor.

ADJUSTMENT

This section explains how to adjust the weight rack. See the EXERCISE GUIDELINES on page 11 for important information about how to get the most benefit from your exercise program. Also, refer to the accompanying exercise guide to see the correct form for several exercises.

ADJUSTING THE WEIGHT RESTS AND THE SPOTTERS

To adjust the height of the Weight Rests (9, 10), first remove the Weight Rests from the Front Uprights (3, 4), and then insert them into the desired adjustment holes in the Uprights. **Make sure that the Weight Rests are at the same height.**

To adjust the height of the Spotters (11, 12), first remove the Spotters from the Front Uprights (3, 4), and then insert them into the desired adjustment holes in the Uprights. **Make sure that the Spotters are at the same height and make sure that there are at least three adjustment holes between the Weight Rests and the Spotters.**

⚠ WARNING: Do not place more than 310 lbs. (141 kg) on the Weight Rests (9, 10). Always place both Weight Rests at the same height and both Spotters (11, 12) at the same height. Make sure that there are at least three adjustment holes between the Weight Rests and the Spotters.

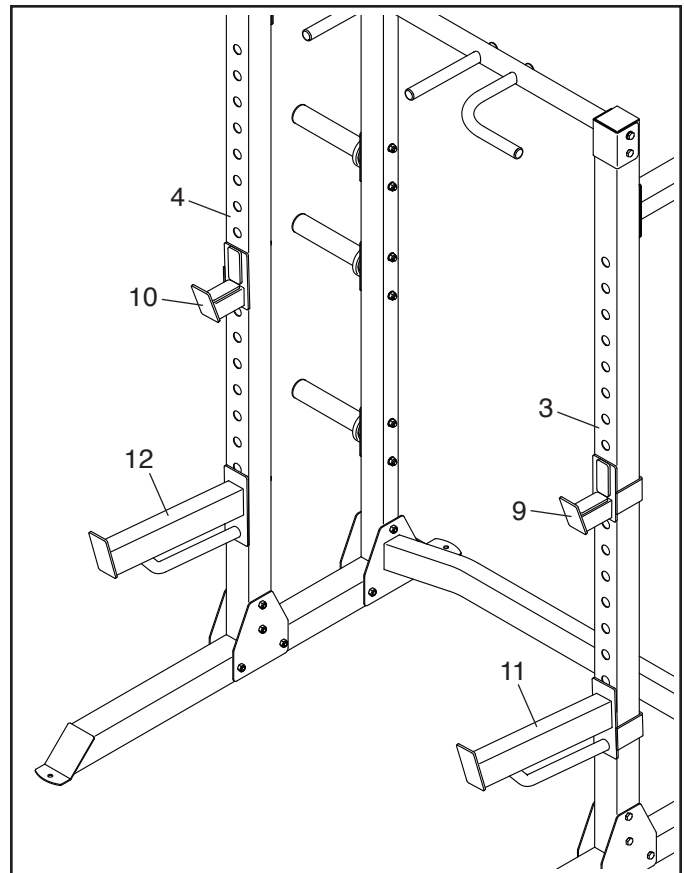

STORING WEIGHTS

Store weights (not included) by placing them on the Storage Tubes (14) on the Rear Uprights (5, 6).

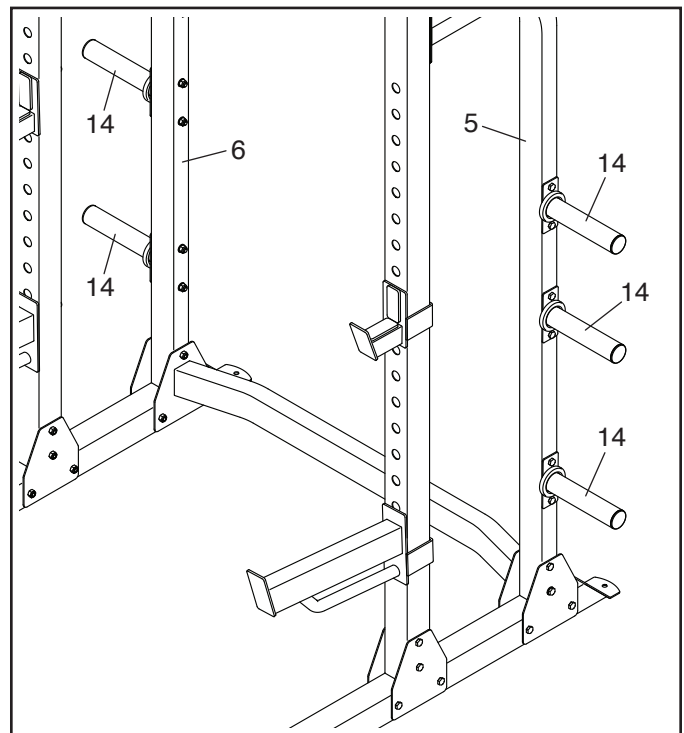

EXERCISE GUIDELINES

FOUR TYPES OF STRENGTH WORKOUTS

Note: A “repetition” is one complete cycle of an exercise, such as one sit-up. A “set” is a series of repetitions.

Muscle Building—Work your muscles near their maximum capacity and progressively increase the intensity of your exercise. Adjust the intensity level of an individual exercise as follows:

- Change the amount of resistance used.
- Change the number of repetitions or sets performed.

Use your own judgment to determine the amount of resistance that is right for you. Begin with 3 sets of 8 repetitions for each exercise you perform. Rest for 3 minutes after each set. When you can complete 3 sets of 12 repetitions without difficulty, increase the amount of resistance.

Toning—Tone your muscles by working them to a moderate percentage of their capacity. Select a moderate amount of resistance and increase the number of repetitions in each set. Complete as many sets of 15 to 20 repetitions as possible without discomfort. Rest for 1 minute after each set. Work your muscles by completing more sets rather than by using high amounts of resistance.

Weight Loss—To lose weight, use a low amount of resistance and increase the number of repetitions in each set. Exercise for 20 to 30 minutes, resting for a maximum of 30 seconds between sets.

Cross Training—Combine strength training and aerobic exercise by following this type of program:

- Strength training workouts on Monday, Wednesday, and Friday.
- 20 to 30 minutes of aerobic exercise on Tuesday and Thursday.
- One full day of rest each week to give your body time to regenerate.

WORKOUT GUIDELINES

Familiarize yourself with the equipment and learn the proper form for each exercise. Use your own judgment to determine the appropriate length of time for each

workout, and the numbers of repetitions and sets to complete. Progress at your own pace and be sensitive to your body’s signals. Follow each workout with at least one day of rest.

Warming Up—Start with 5 to 10 minutes of stretching and light exercise. A warm-up increases your body temperature, heart rate, and circulation in preparation for exercise.

Working Out—Include 6 to 10 different exercises in each workout. Select exercises for every major muscle group, emphasizing areas that you want to develop. To give balance and variety to your workouts, vary the exercises from workout to workout.

Cooling Down—Finish with 5 to 10 minutes of stretching. Stretching increases the flexibility of your muscles and helps to prevent post-exercise problems.

EXERCISE FORM

Move through the full range of motion for each exercise and move only the appropriate parts of the body. Perform the repetitions in each set smoothly and without pausing. The exertion stage of each repetition should last about half as long as the return stage. Exhale during the exertion stage of each repetition and inhale during the return stroke. Never hold your breath.

Rest for a short period of time after each set:

- Muscle Building—Rest for three minutes after each set.
- Toning—Rest for one minute after each set.
- Weight Loss—Rest for 30 seconds after each set.

STAYING MOTIVATED

For motivation, keep a record of each workout. Write the date, the exercises performed, the resistance used, and the numbers of sets and repetitions completed. Record your weight and key body measurements once a month. To achieve good results, make exercise a regular and enjoyable part of your life.

EXERCISE LOG

Make copies of this page, and use the copies to schedule and record your strength and aerobic workouts. Scheduling and recording your workouts will help you to make exercise a regular and enjoyable part of your life.

Strength

Date:

___ / ___ / ___

Exercise	Lbs.	Sets	Reps	Exercise	Lbs.	Sets	Reps
1.				6.			
2.				7.			
3.				8.			
4.				9.			
5.				10.			

Aerobic

Date:

___ / ___ / ___

Exercise	Time	Distance	Speed

Strength

Date:

___ / ___ / ___

Exercise	Lbs.	Sets	Reps	Exercise	Lbs.	Sets	Reps
1.				6.			
2.				7.			
3.				8.			
4.				9.			
5.				10.			

Aerobic

Date:

___ / ___ / ___

Exercise	Time	Distance	Speed

Strength

Date:

___ / ___ / ___

Exercise	Lbs.	Sets	Reps	Exercise	Lbs.	Sets	Reps
1.				6.			
2.				7.			
3.				8.			
4.				9.			
5.				10.			

Aerobic

Date:

___ / ___ / ___

Exercise	Time	Distance	Speed

NOTES

PART LIST

Model No. 831.15968.0 R0716A

Key No.	Qty.	Description	Key No.	Qty.	Description
1	1	Right Base	13	6	Support Plate
2	1	Left Base	14	6	Storage Tube
3	1	Right Front Upright	15	6	Large Round Cap
4	1	Left Front Upright	16	6	Bumper
5	1	Right Rear Upright	17	2	Square Cap
6	1	Left Rear Upright	18	8	Small Round Cap
7	1	Crossbar	19	32	M10 x 95mm Bolt
8	1	Pull-up Bar	20	20	M10 Washer
9	1	Right Weight Rest	21	28	M10 Locknut
10	1	Left Weight Rest	22	4	M10 x 20mm Screw
11	1	Right Spotter	23	8	M10 Split Washer
12	1	Left Spotter	*	—	User's Manual

Note: Specifications are subject to change without notice. For information about ordering replacement parts, see the back cover of this manual. **If a part is missing, call 1-877-992-5999.** *These parts are not illustrated.

EXPLODED DRAWING

Model No. 831.15968.0 R0716A

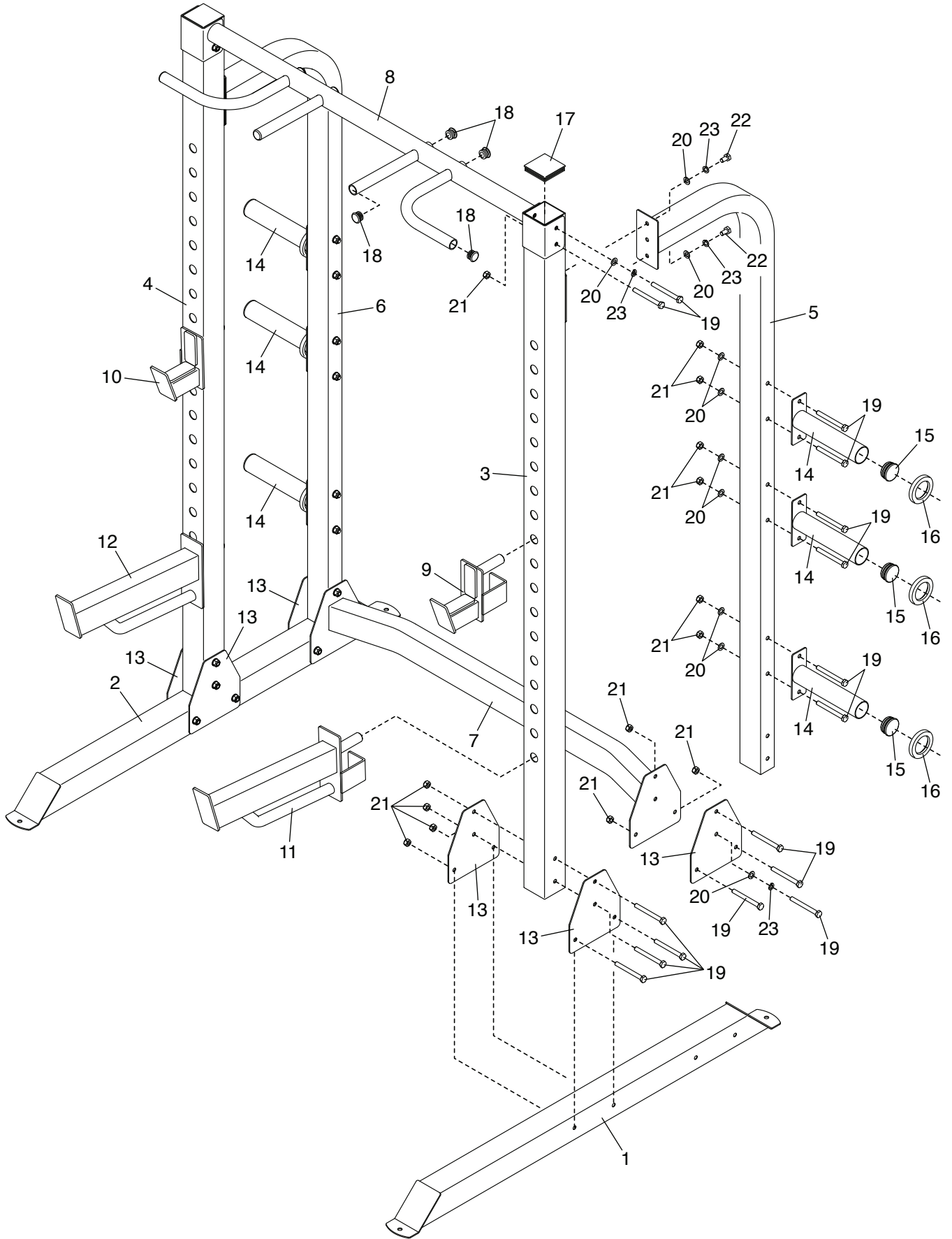

Get it fixed, at your home or ours!

Your Home

For repair—in **your home**—of **all** major brand appliances, lawn and garden equipment, or heating and cooling systems, **no matter who made it, no matter who sold it!**

For the replacement parts, accessories, and user's manuals that you need to do-it-yourself.

For Sears professional installation of home appliances and items like garage door openers and water heaters.

1-800-4-MY-HOME® (1-800-469-4663)

Call anytime, day or night (U.S.A. and Canada)

www.sears.com

www.sears.ca

Our Home

For repair of carry-in items like vacuums, lawn equipment, and electronics, call or go on-line for the location of your nearest **Sears Parts & Repair Center.**

1-800-488-1222 Call anytime, day or night (U.S.A. only)

www.sears.com

To purchase a protection agreement (U.S.A.) or maintenance agreement (Canada) on a product serviced by Sears:

1-800-827-6655 (U.S.A.)

1-800-361-6665 (Canada)

Para pedir servicio de reparación a domicilio, y para ordenar piezas:

1-888-SU-HOGAR® (1-888-784-6427)



® Registered Trademark / ™ Trademark / ™ Service Mark of Sears Brands, LLC
® Marca Registrada / ™ Marca de Fábrica / ™ Marca de Servicio de Sears Brands, LLC

90 DAY FULL WARRANTY

If this Sears Weight Rack Exerciser fails due to a defect in material or workmanship within 90 days of the date of purchase, call 1-800-4-MY-HOME® (1-800-469-4663) to arrange for free repair (or replacement if repair proves impossible).

This warranty does not apply when the Weight Rack Exerciser is used commercially or for rental purposes. This warranty gives you specific legal rights, and you may also have other rights which vary from state to state.

Sears, Roebuck and Co., Hoffman Estates, IL 60179