

PRO-FORM[®]

HYBRID TRAINER

Model No. 831.23890.0

Serial No. _____

Write the serial number in the space above for reference.

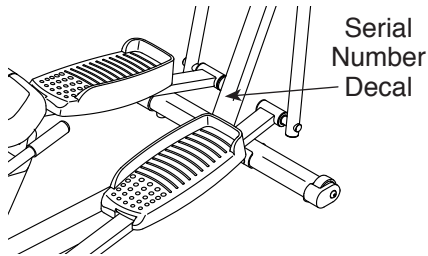

- Assembly
- Operation
- Maintenance
- Part List and Drawing

Sears, Roebuck and Co.
Hoffman Estates, IL 60179

CAUTION

Read all precautions and instructions in this manual before using this equipment. Keep this manual for future reference.

EXERCISER User's Manual

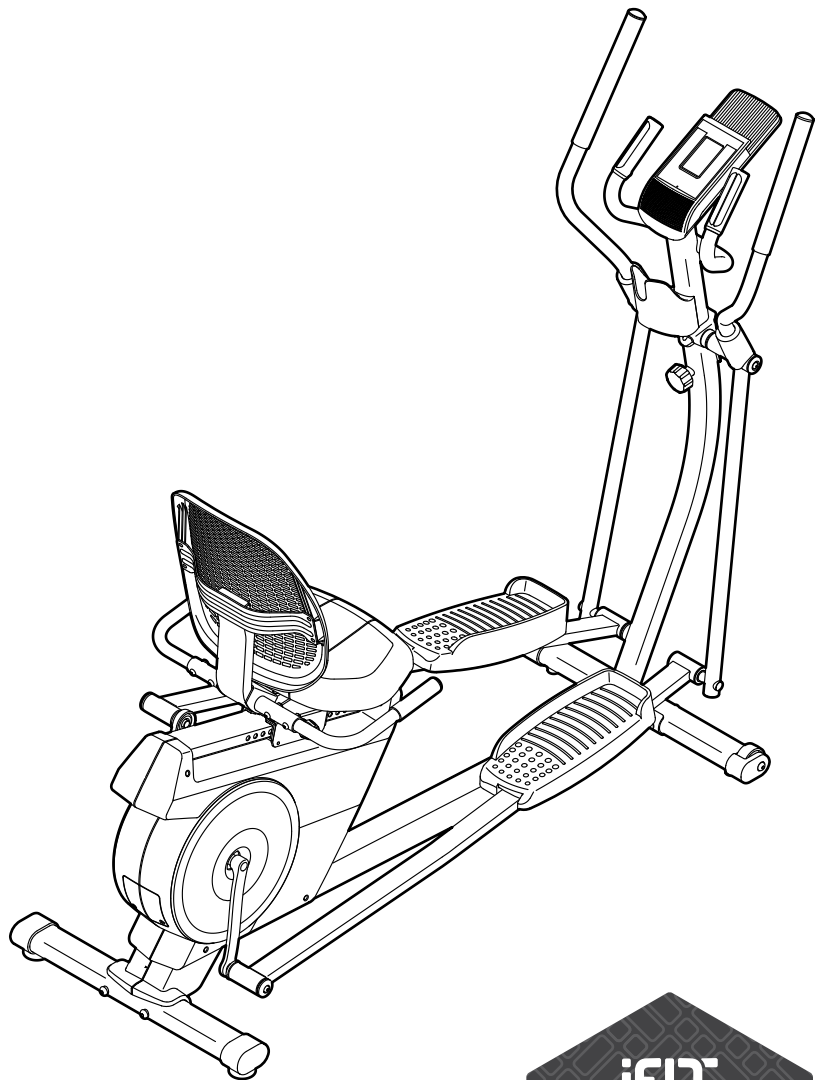

TABLE OF CONTENTS

WARNING DECAL PLACEMENT 2

IMPORTANT PRECAUTIONS 3

BEFORE YOU BEGIN 4

PART IDENTIFICATION CHART 5

ASSEMBLY 6

HOW TO USE THE HYBRID TRAINER 15

FCC INFORMATION 23

MAINTENANCE AND TROUBLESHOOTING 24

EXERCISE GUIDELINES 26

PART LIST 28

EXPLODED DRAWING 30

HOW TO CONTACT CUSTOMER CARE Back Cover

90 DAY FULL WARRANTY Back Cover

WARNING DECAL PLACEMENT

This drawing shows the location(s) of the warning decal(s). **If a decal is missing or illegible, call 1-888-533-1333 and request a free replacement decal. Apply the decal in the location shown.** Note: The decal(s) may not be shown at actual size.

WARNING
Keep hands and fingers clear of this area.

WARNING

- Misuse of this machine may result in serious injury.
- Read user's manual prior to use and follow all warnings and instructions.
- Do not allow children on or around machine.
- Pedals continue to spin when you stop pedaling.
- Spinning pedals can cause injury.
- Reduce pedal speed in a controlled manner.
- User weight must not exceed 350 lbs / 159 kgs.
- This product should always be used on a level surface.
- This product is not intended for therapeutic use.
- Replace label if damaged, illegible, or removed.

App Store is a trademark of Apple Inc., registered in the U.S. and other countries. Android and Google Play are trademarks of Google Inc. The BLUETOOTH® word mark and logos are registered trademarks of Bluetooth SIG, Inc. and are used under license. IOS is a trademark or registered trademark of Cisco in the U.S. and other countries and is used under license.

IMPORTANT PRECAUTIONS

⚠️ WARNING: To reduce the risk of serious injury, read all important precautions and instructions in this manual and all warnings on your hybrid trainer before using your hybrid trainer. Sears assumes no responsibility for personal injury or property damage sustained by or through the use of this product.

1. It is the responsibility of the owner to ensure that all users of the hybrid trainer are adequately informed of all precautions.
2. Before beginning any exercise program, consult your physician. This is especially important for persons over age 35 or persons with pre-existing health problems.
3. The hybrid trainer is not intended for use by persons with reduced physical, sensory, or mental capabilities or lack of experience and knowledge, unless they are given supervision or instruction about use of the hybrid trainer by someone responsible for their safety.
4. Use the hybrid trainer only as described in this manual.
5. The hybrid trainer is intended for home use only. Do not use the hybrid trainer in a commercial, rental, or institutional setting.
6. Keep the hybrid trainer indoors, away from moisture and dust. Do not put the hybrid trainer in a garage or covered patio or near water.
7. Place the hybrid trainer on a level surface, with at least 3 ft. (0.9 m) of clearance in the front and rear of the hybrid trainer and 2 ft. (0.6 m) on each side. To protect the floor or carpet from damage, place a mat under the hybrid trainer.
8. Inspect and properly tighten all parts each time the hybrid trainer is used. Replace any worn parts immediately.
9. Keep children under age 13 and pets away from the hybrid trainer at all times.
10. The hybrid trainer should not be used by persons weighing more than 350 lbs. (159 kg).
11. Wear appropriate clothes while exercising; do not wear loose clothes that could become caught on the hybrid trainer. Always wear athletic shoes for foot protection while exercising.
12. Hold the handlebars or the upper body arms when mounting, dismounting, or using the hybrid trainer.
13. The heart rate monitor is not a medical device. Various factors may affect the accuracy of heart rate readings. The heart rate monitor is intended only as an exercise aid in determining heart rate trends in general.
14. The hybrid trainer does not have a freewheel; the pedals will continue to move until the flywheel stops. Reduce your pedaling speed in a controlled way.
15. Keep your back straight while using the hybrid trainer; do not arch your back.
16. Over exercising may result in serious injury or death. If you feel faint, if you become short of breath, or if you experience pain while exercising, stop immediately and cool down.

BEFORE YOU BEGIN

Thank you for selecting the revolutionary PROFORM® HYBRID TRAINER. The HYBRID TRAINER provides an impressive selection of features designed to make your workouts at home more effective and enjoyable.

For your benefit, read this manual carefully before you use the hybrid trainer. If you have questions after reading this manual, please see the back cover of this

manual. To help us assist you, note the product model number and serial number before contacting us. The model number and the location of the serial number decal are shown on the front cover of this manual.

Before reading further, please familiarize yourself with the parts that are labeled in the drawing below.

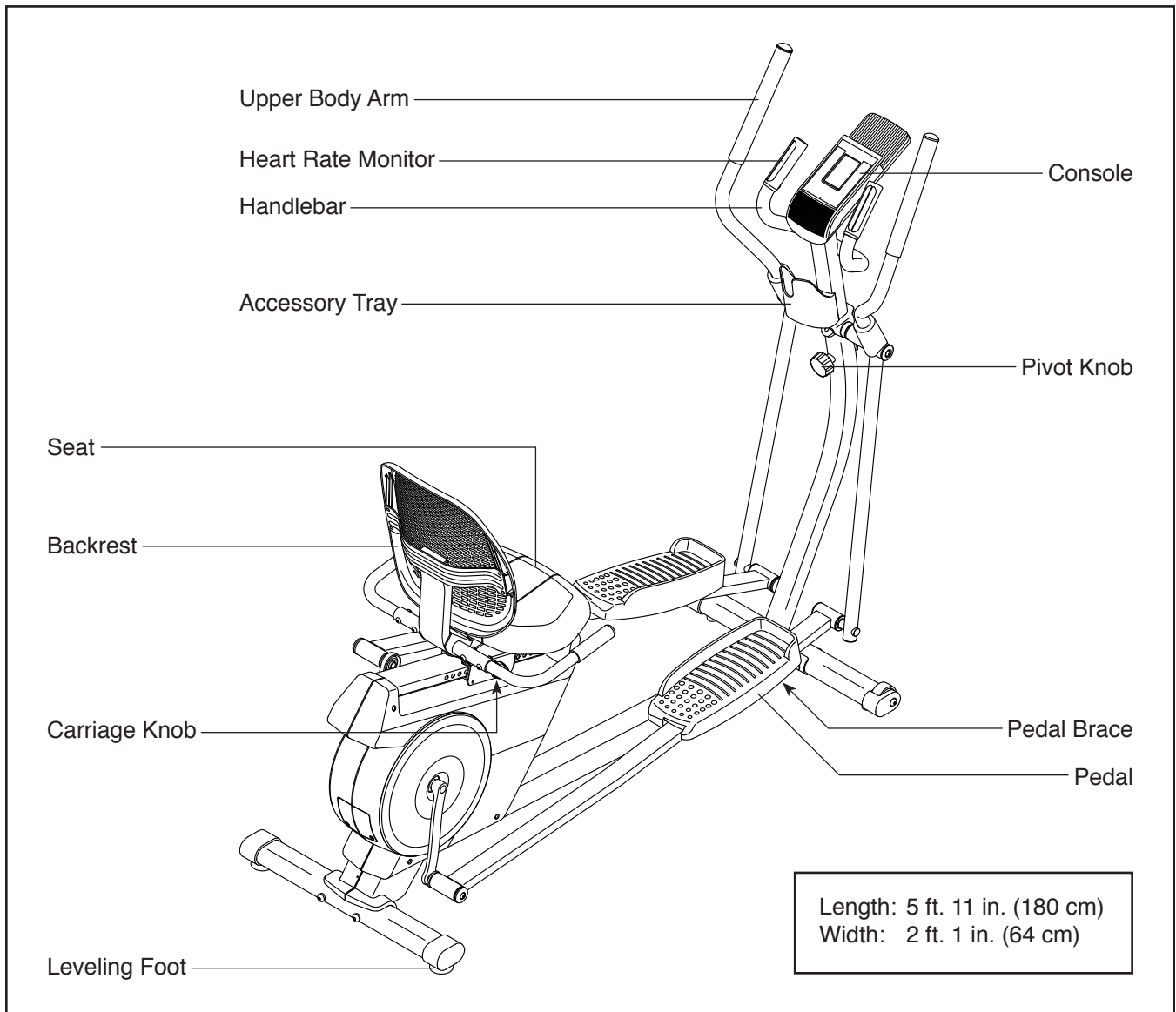

PART IDENTIFICATION CHART

Use the drawings below to identify the small parts needed for assembly. The number in parentheses below each drawing is the key number of the part, from the PART LIST near the end of this manual. The number following the key number is the quantity needed for assembly. **Note: If a part is not in the hardware kit, check to see if it has been preassembled. Extra parts may be included. If a part is missing, please call 1-888-533-1333.**

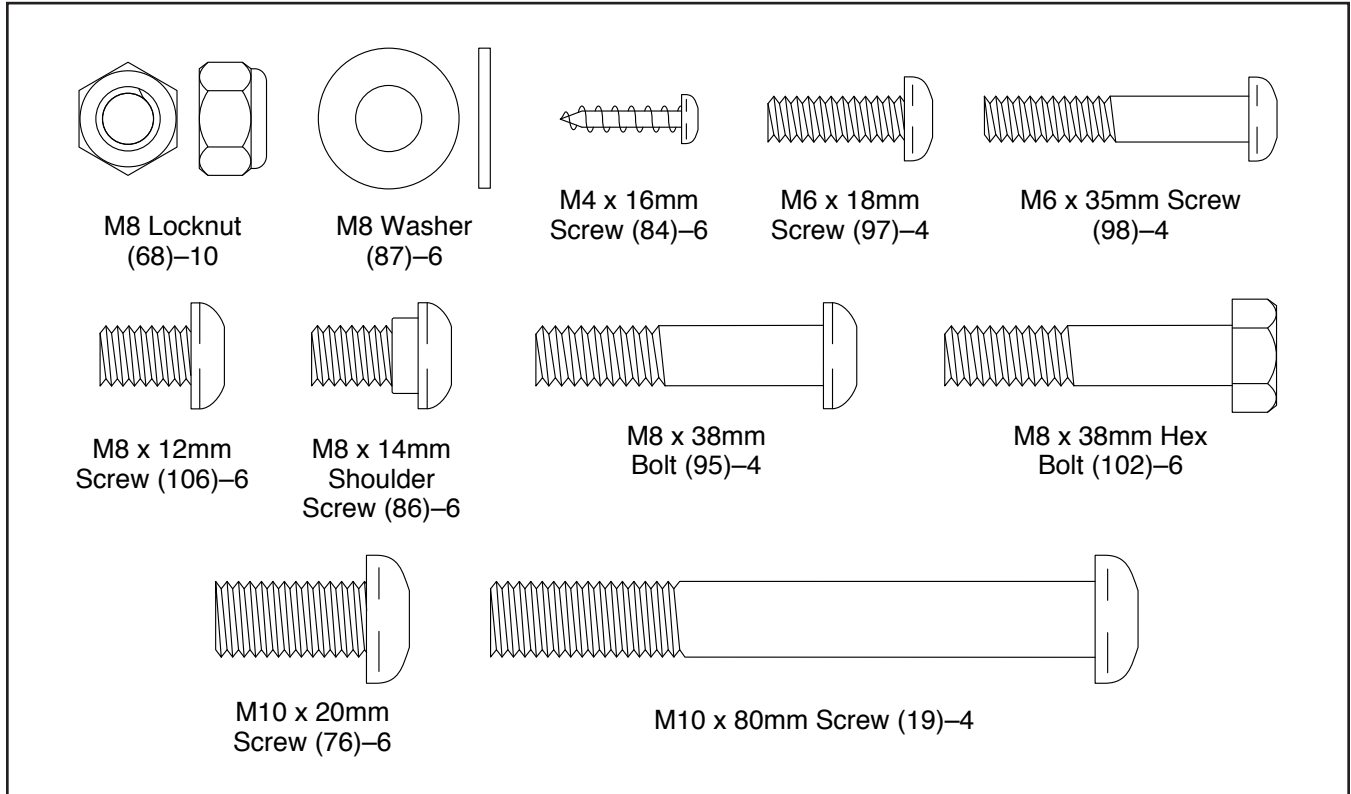

ASSEMBLY

- Assembly requires two persons.
- Place all parts in a cleared area and remove the packing materials. Do not dispose of the packing materials until you finish assembly.
- Left parts are marked “L” or “Left” and right parts are marked “R” or “Right.”
- To identify small parts, see page 5.

- In addition to the included tool(s), assembly requires the following tools:

one Phillips screwdriver 

one adjustable wrench 

Assembly may be easier if you have a set of wrenches. To avoid damaging parts, do not use power tools.

1. **Go to www.proformservice.com/registration on your computer and register your product.**

- activates your warranty
- saves you time if you ever need to contact Customer Care
- allows us to notify you of upgrades and offers

Note: If you do not have internet access, call 1-888-533-1333 and register your product.

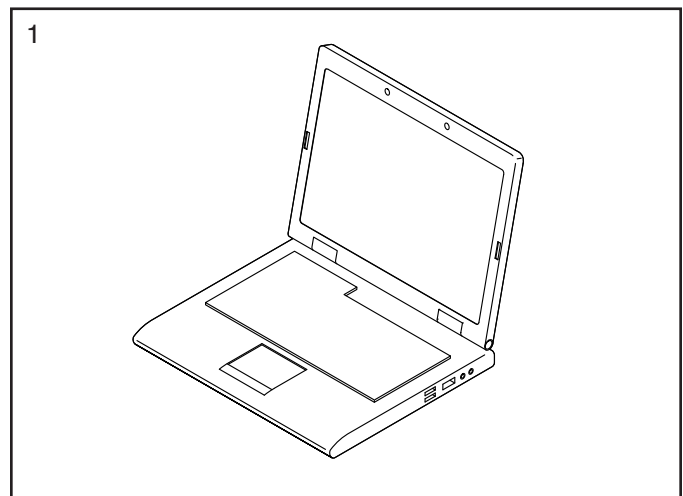

2. With the help of a second person, place some of the packing materials (not shown) under the Frame (1).

Orient the Rear Stabilizer (6) so that the large holes (A) are facing the Frame (1). Attach the Rear Stabilizer to the Frame with two M10 x 80mm Screws (19).

Then, remove the packing materials from under the Frame (1).

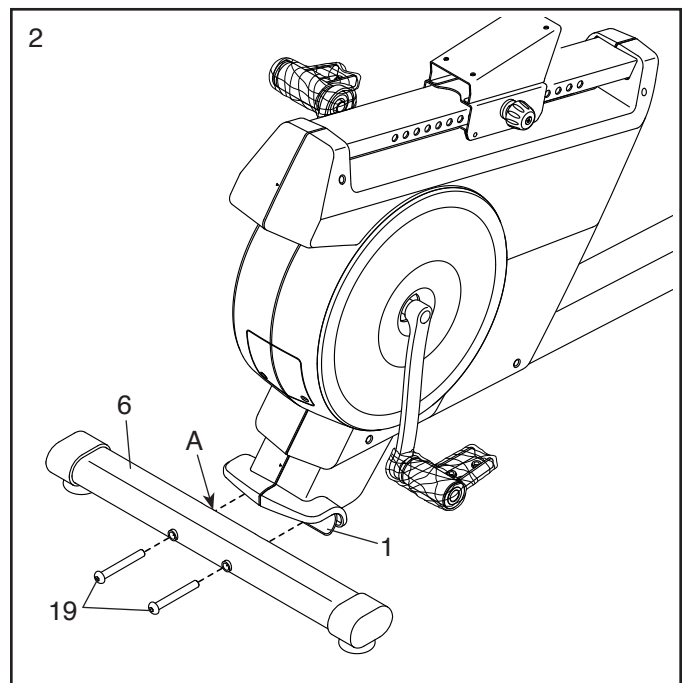

3. Orient the Upright (2) and the Front Stabilizer (5) so that the large holes (B) are facing the Upright.

Attach the Front Stabilizer (5) to the Upright (2) with two M10 x 80mm Screws (19).

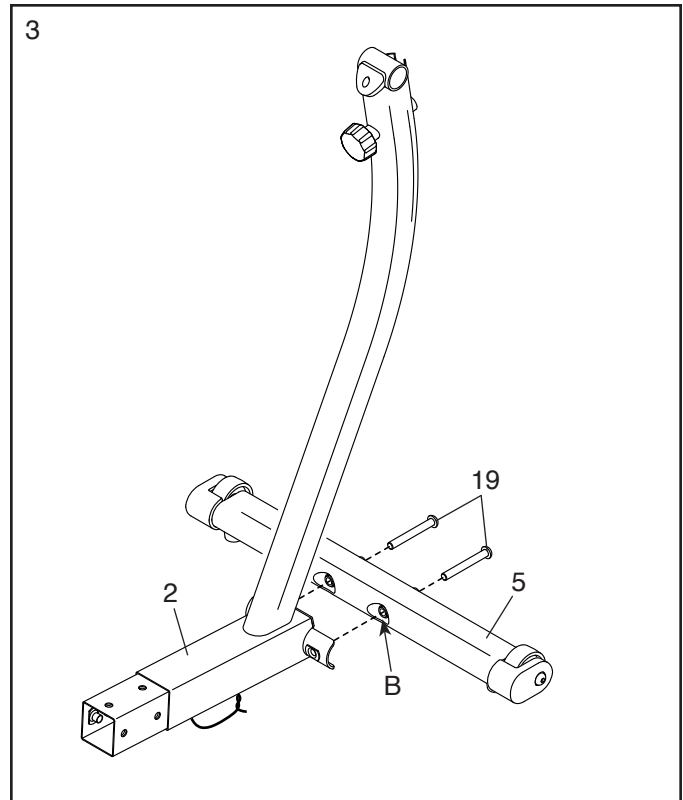

4. Set the Upright (2) near the Frame (1) as shown.

Locate the wire tie (C) in the Frame (1) and pull the Main Wire (96) out of the underside of the Frame.

Repeat this action to pull the Upper Wire (not shown) out of the underside of the Upright (2) with the wire tie (D).

Then, untie and discard the wire ties.

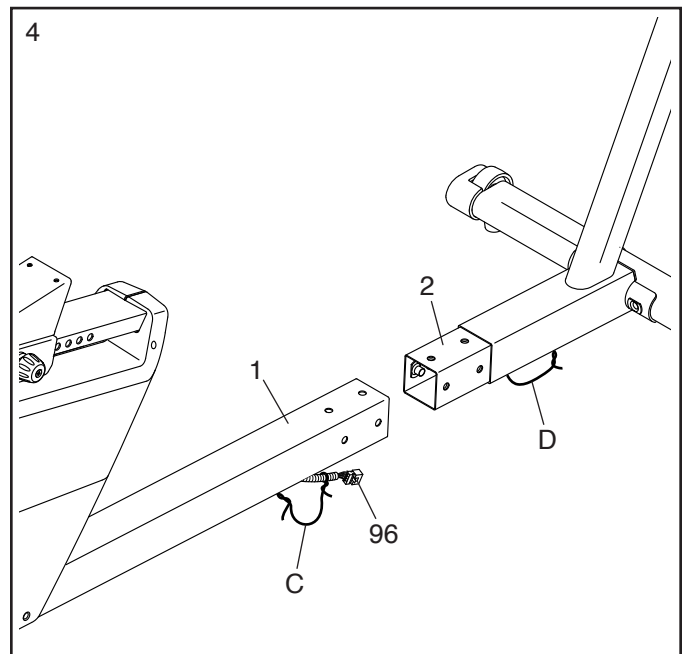

5. **Tip: Avoid pinching the wires.** Insert the Upright (2) into the Frame (1).

Attach the Upright (2) with six M10 x 20mm Screw (76); **start all the Screws, and then tighten them.**

Then, connect the Upper Wire (94) to the Main Wire (96).

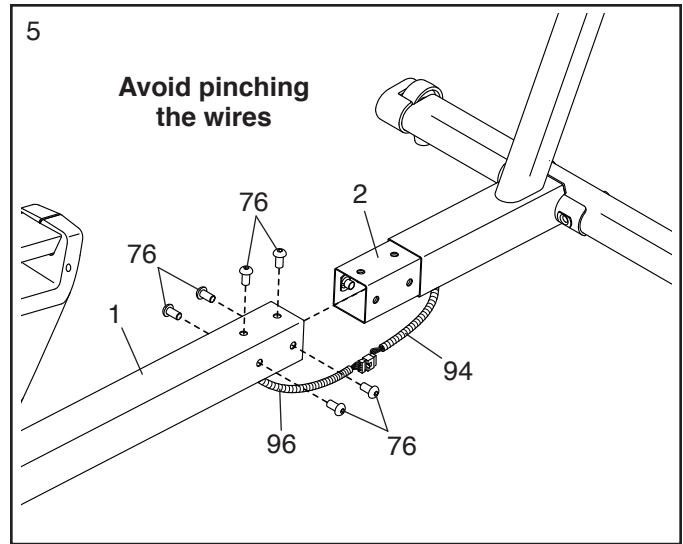

6. Locate the wire tie (E) in the top of the Upright (2) and pull the Upper Wire (94) out of the Upright. Then, untie and discard the wire tie.

Tip: Avoid pinching the wires. Attach the Wire Cover (20) to the Frame (1) and the Upright (2) with two M4 x 16mm Screws (84). **Make sure that the tab (F) on the Wire Cover is in the location shown.**

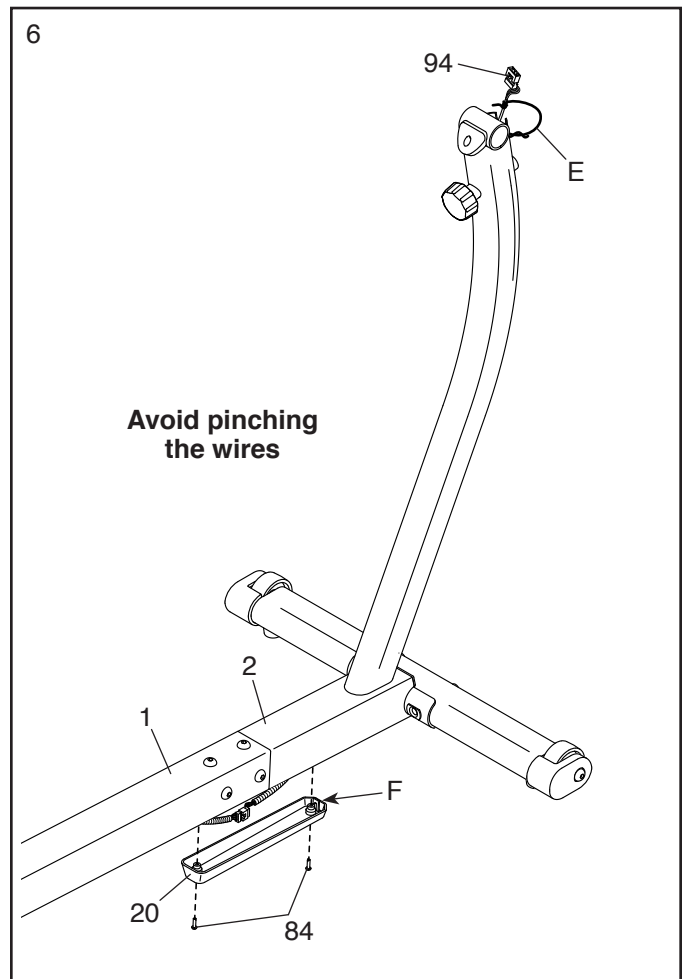

7. Have a second person hold the Pivot Bracket (3) near the Upright (2).

Locate the wire tie (G) in the Pivot Bracket (3). Tie the wire tie to the Upper Wire (94) and then pull the other end of the wire tie until the Upper Wire is routed through the Pivot Bracket.

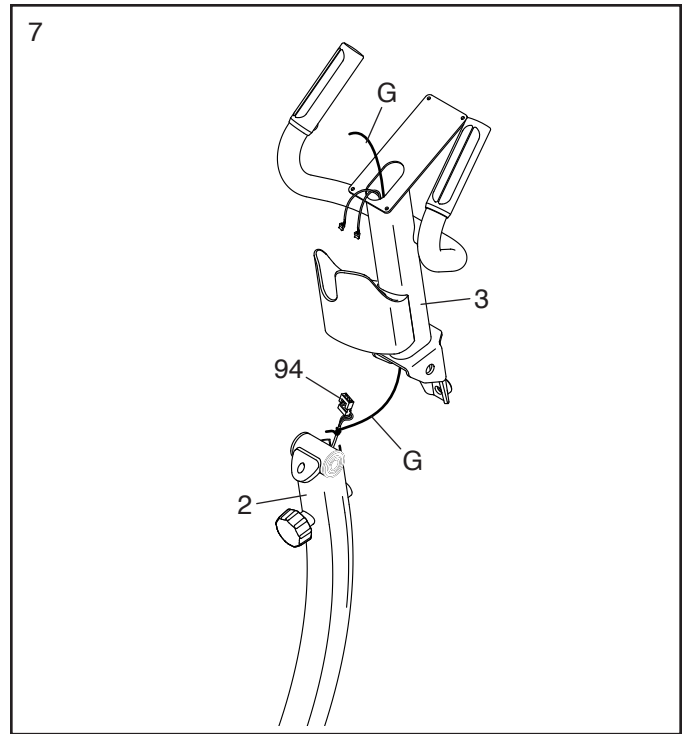

8. Using a plastic bag to keep your fingers clean, apply a generous amount of the included grease to the Pivot Axle (80).

Tip: Avoid pinching the Upper Wire (94). Slide the Pivot Bracket (3) onto the Upright (2) and hold it in place.

Next, insert the Pivot Axle (80) into the Pivot Bracket (3) and into the Upright (2). Center the Pivot Axle.

Then, tighten the Pivot Knob (13) into the Pivot Bracket (3).

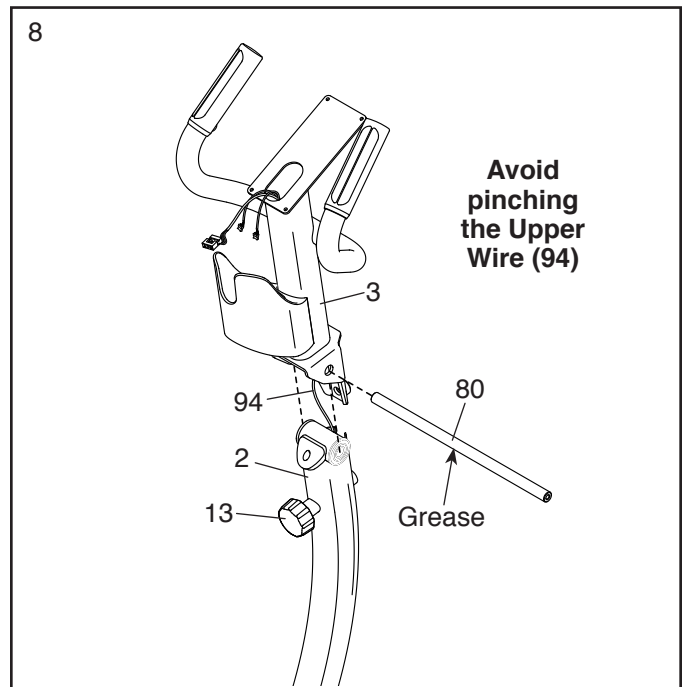

9. Identify the Right Pedal Arm (9) and the Right Pivot Leg (8), and orient them as shown.

Apply a generous amount of the included grease to the axle on the Right Pivot Leg (8).

Then, slide the Right Pedal Arm (9) onto the Right Pivot Leg (8). Attach the Right Pedal Arm with an M8 x 14mm Shoulder Screw (86), a Pivot Cover (83), and an M8 Washer (87).

Repeat this step for the Left Pedal Arm (not shown) and the Left Pivot Leg (not shown).

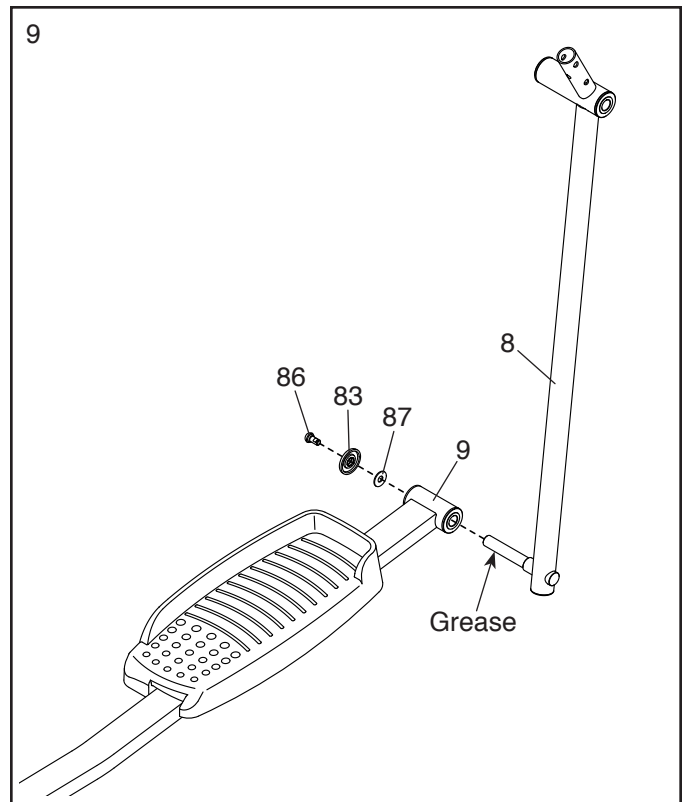

10. Slide a Pivot Spacer (79) onto each side of the Pivot Axle (80).

Then, slide the Right and Left Pivot Legs (8, 11) onto the Pivot Axle (80); **make sure that the Pivot Legs are on the correct sides.**

Then, tighten an M8 x 14mm Shoulder Screw (86), a Pivot Cover (83), and an M8 Washer (87) into each end of the Pivot Axle (80) **at the same time.**

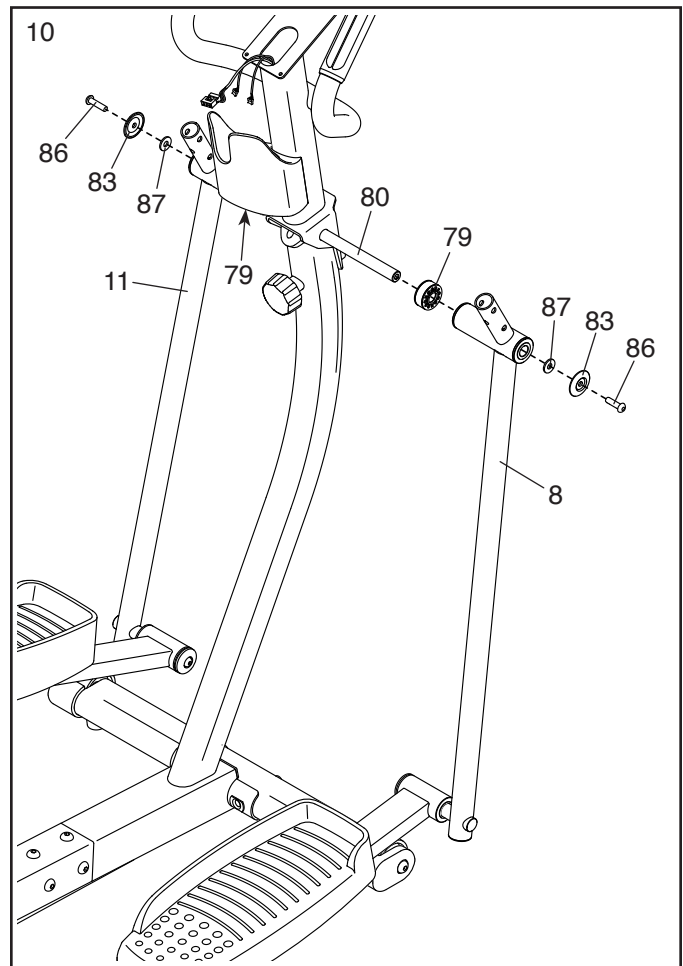

11. Remove and discard the packaging on the Right Crank Bracket (30). Then, tighten an M8 x 14mm Shoulder Screw (86) with a Pivot Cover (83) and an M8 Washer (87) into the right Crank Arm (24).

Next, slide the Right Pedal Arm (9) onto the Right Crank Bracket (30).

Then, attach the Right Pedal Arm (9) with three M8 x 12mm Screws (106); **start all the Screws, and then tighten them.**

Repeat this step on the other side of the hybrid trainer.

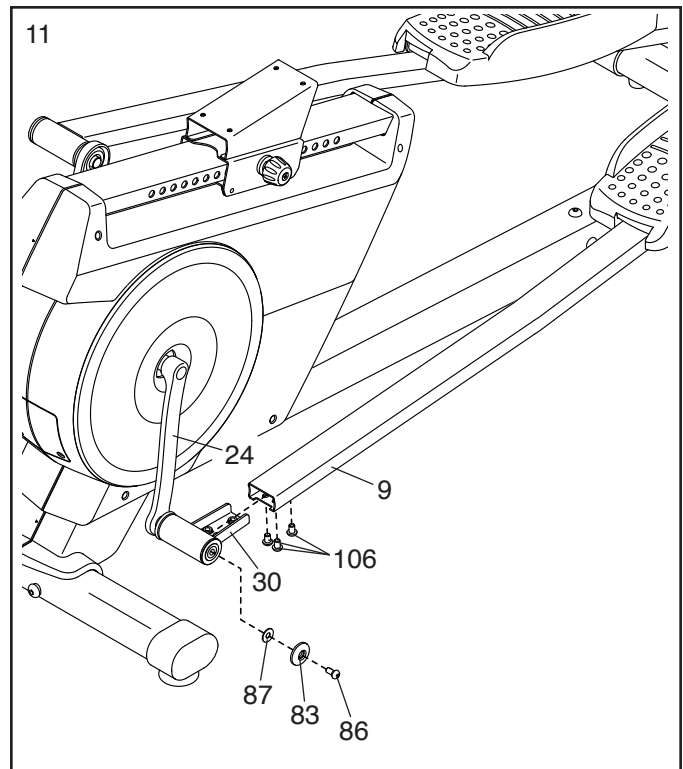

12. The Console (4) requires four D batteries (not included); alkaline batteries are recommended. Do not use old and new batteries together or alkaline, standard, and rechargeable batteries together. **IMPORTANT: If the Console has been exposed to cold temperatures, allow it to warm to room temperature before you insert batteries. Otherwise, you may damage the console displays or other electronic components.**

Remove the screws and the battery cover (H) from the back of the Console (4), insert batteries into the battery compartment, and then reattach the battery cover. **Make sure to orient the batteries as shown by the diagrams inside the battery compartment.**

To purchase an optional power adapter, call the telephone number on the cover of this manual. To avoid damaging the Console (4), use only a manufacturer-supplied regulated power adapter. Plug one end of the power adapter into the receptacle **inside** the battery compartment on the Console and route the power adapter through the notch in the battery cover; plug the other end into an outlet installed in accordance with all local codes and ordinances.

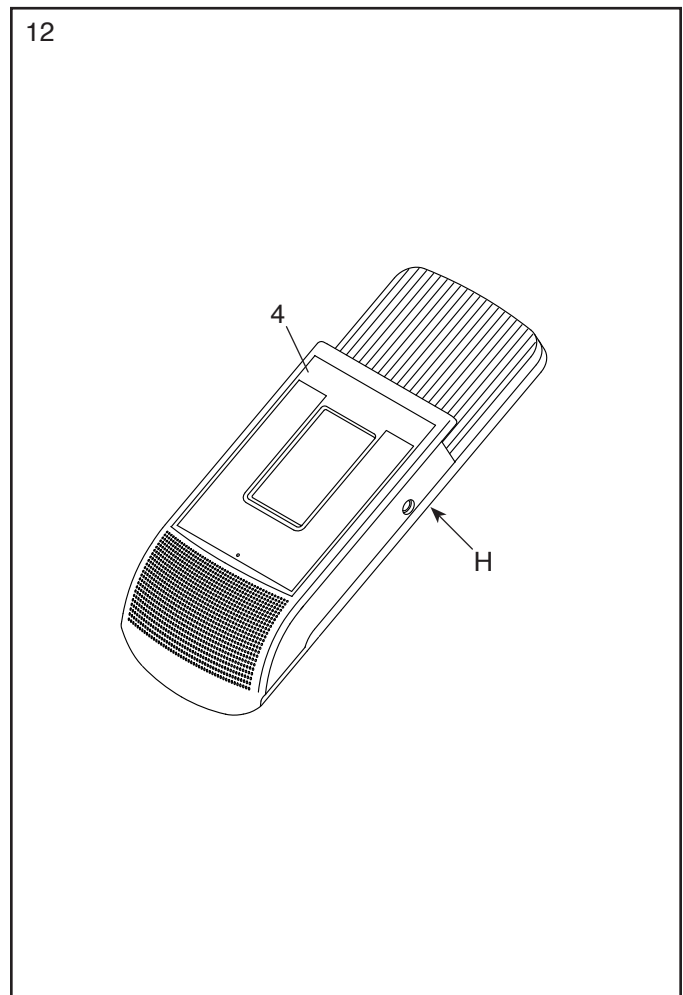

13. Untie and discard the wire tie on the Upper Wire (94).

While a second person holds the Console (4) near the Pivot Bracket (3), plug the Upper Wire (94) and the Left and Right Pulse Wires (103, 104) into the receptacles on the Console.

The connectors on the Wires (94, 103, 104) should slide easily into the receptacles and snap into place. If a connector does not slide easily into a receptacle, turn the connector and try again. **If you do not connect the connectors properly, the Console (4) may become damaged when you use the hybrid trainer.**

Insert the excess wire into the Pivot Bracket (3).

Tip: Avoid pinching the wires. Attach the Console (4) to the Pivot Bracket (3) with four M4 x 16mm Screws (84); **start all the Screws, and then tighten them.**

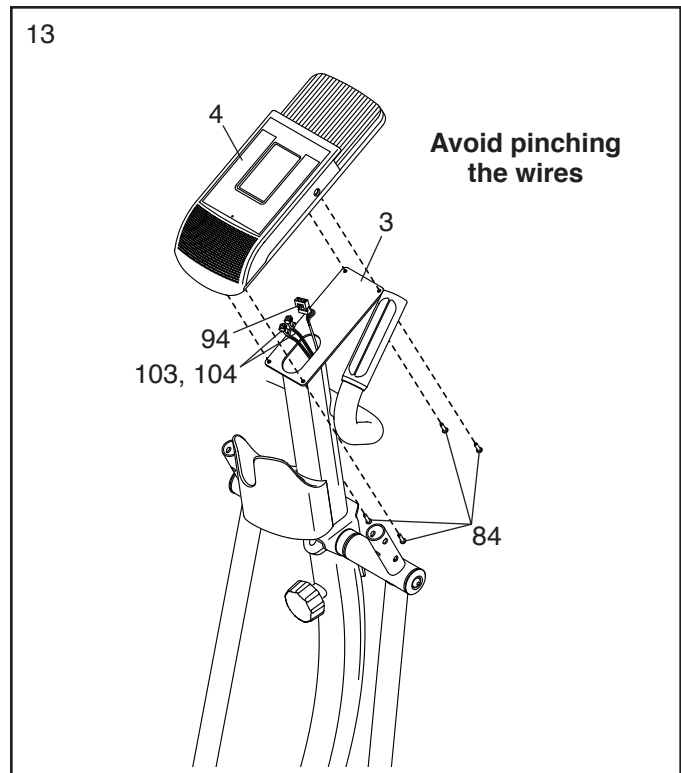

14. Identify the Right Upper Body Arm (7).

Orient an Upper Body Cover (78) as shown, and slide it upward onto the Right Upper Body Arm (7).

Attach the Right Upper Body Arm (7) to the Right Pivot Leg (8) with three M8 x 38mm Hex Bolts (102) and three M8 Locknuts (68); **start all the Hex Bolts, and then tighten them. Make sure that the Locknuts are inside the hexagonal holes (I).**

Then, slide the Upper Body Cover (78) downward onto the Right Pivot Leg (8).

Repeat this step on the other side of the hybrid trainer.

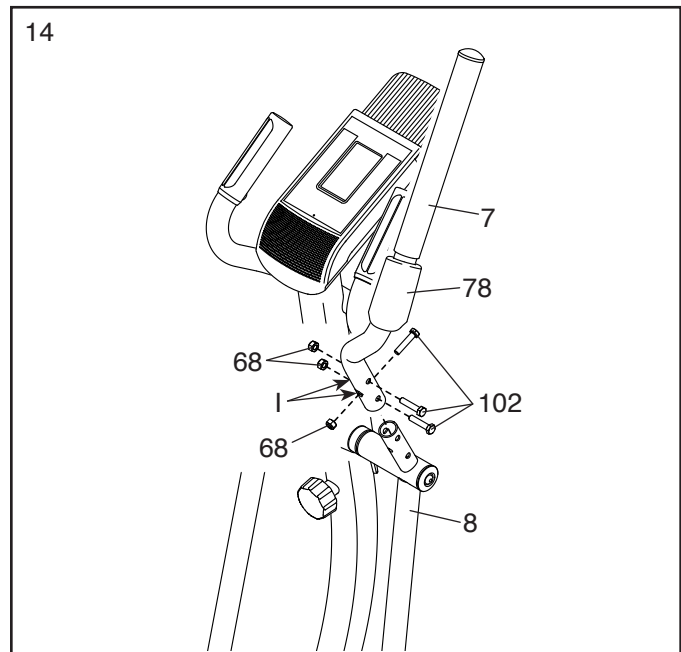

15. Orient the Seat Frame (61) as shown.

Insert a Seat Handlebar (29) into the Seat Frame (61). Attach the Seat Handlebar with two M8 x 38mm Bolts (95) and two M8 Locknuts (68); **make sure that the Locknuts are in the hexagonal holes (J).**

Repeat this step to attach the other Seat Handlebar (29).

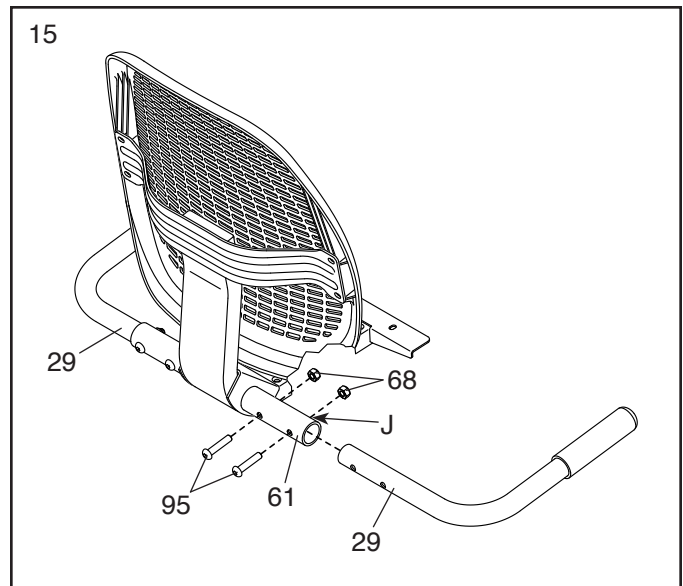

16. Attach the Seat Frame (61) to the Seat Carriage (32) with four M6 x 35mm Screws (98); **start all the Screws, and then tighten them.**

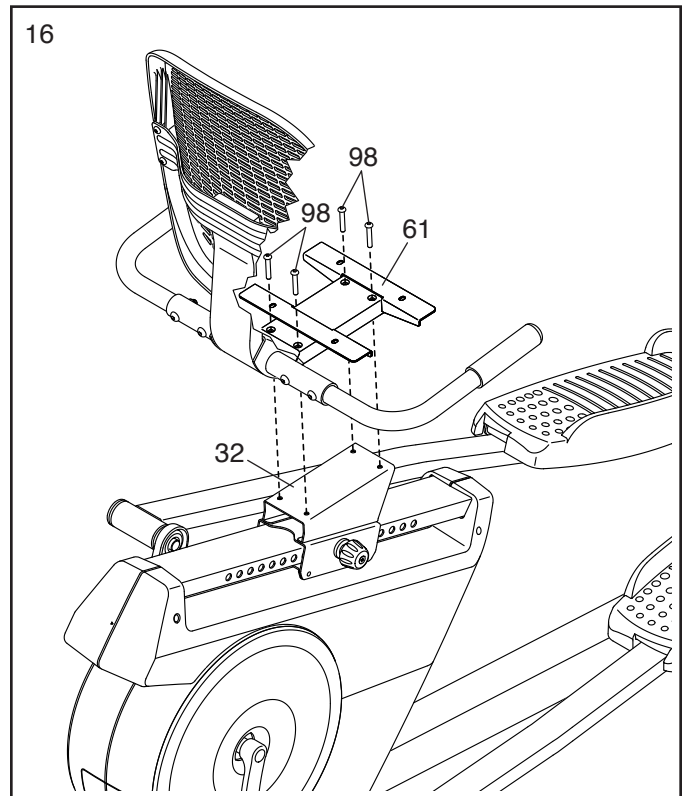

17. Attach the Seat (28) to the Seat Frame (61) with four M6 x 18mm Screws (97) (only two are shown); **start all the Screws, and then tighten them.**

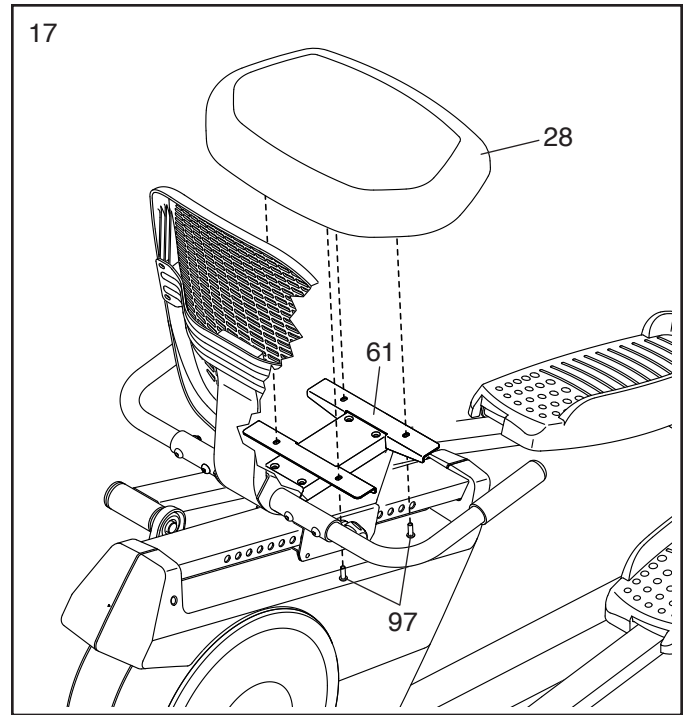

18. **Make sure that all parts of the hybrid trainer are properly tightened.** Extra parts may be included. To protect the floor or carpet from damage, place a mat under the hybrid trainer.

HOW TO USE THE HYBRID TRAINER

HOW TO MOVE THE HYBRID TRAINER

Lift the rear stabilizer until the hybrid trainer will roll on the wheels. Carefully move the hybrid trainer to the desired location, and then lower it to the floor.

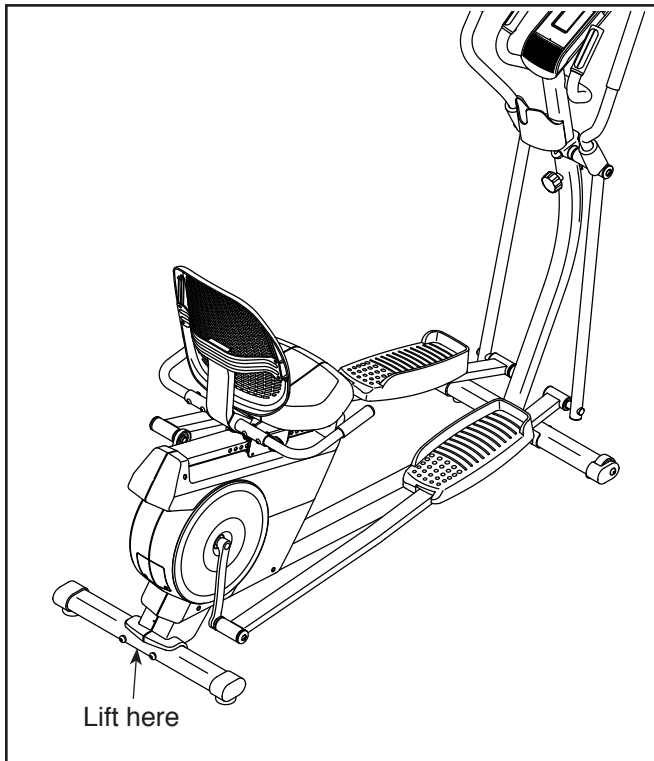

HOW TO LEVEL THE HYBRID TRAINER

If the hybrid trainer rocks slightly on your floor during use, turn one or both of the leveling feet beneath the rear of the frame until the rocking motion is eliminated.

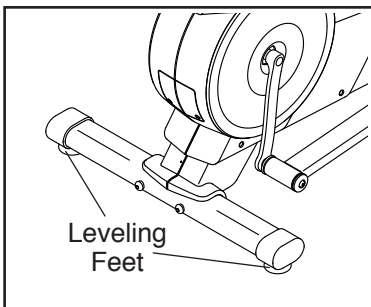

HOW TO USE THE TABLET HOLDER

IMPORTANT: The tablet holder is designed for use with most full-size tablets and smart phones. Do not place any other electronic device or object into the tablet holder.

To insert a tablet or smart phone into the tablet holder, set the bottom edge of the tablet or smart phone in the tray. **Make sure that the tablet or smart phone is firmly secured in the tablet holder.** Reverse these actions to remove the tablet or smart phone from the tablet holder.

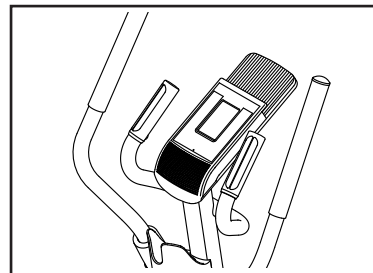

HOW TO USE THE ELLIPTICAL MODE

To use the hybrid trainer as an elliptical, first pivot the pivot bracket to the high position and tighten the pivot knob into the upright.

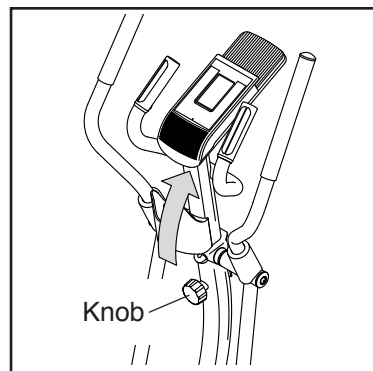

Then, lift a pedal, fold the brace upward, and pivot the pedal downward to the low position. **Repeat this action for the other pedal.**

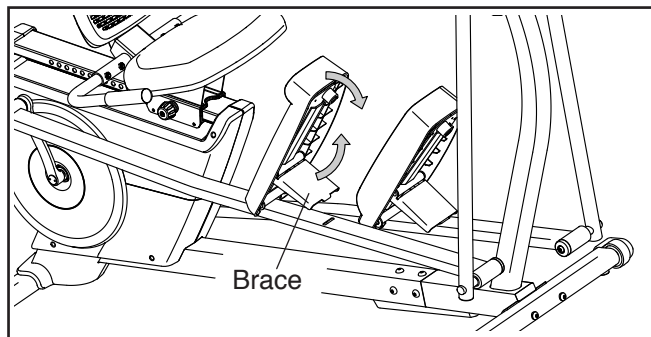

To mount the hybrid trainer in the elliptical mode, hold the handlebars or the upper body arms and step onto the pedal that is in the lower position. Then, step onto the other pedal.

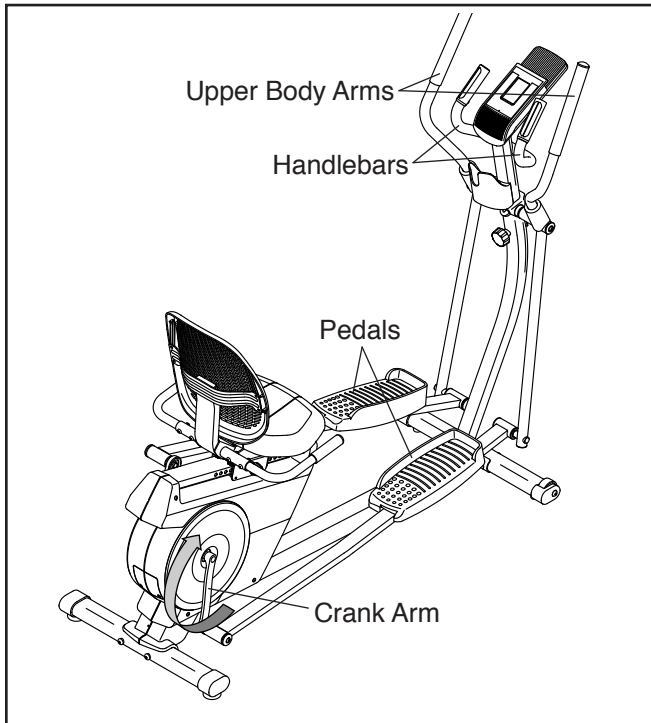

Push the pedals until they begin to move with a continuous motion. **Note: The crank arms can turn in either direction. It is recommended that you move the crank arms in the direction shown by the arrow; however, for variety, you can turn the crank arms in the opposite direction.**

To dismount the hybrid trainer, wait until the pedals come to a complete stop. **Note: The hybrid trainer does not have a free wheel; the pedals will continue to move until the flywheel stops.** When the pedals are stationary, step off the higher pedal first. Then, step off the lower pedal.

HOW TO USE THE RECUMBENT BIKE MODE

To use the hybrid trainer as a recumbent bike, loosen the pivot knob and pivot the pivot bracket to the low position.

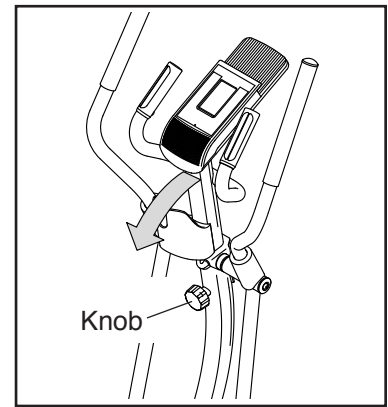

Next, lift a pedal, unfold the brace, and insert the end of the brace into the pedal arm. **Make sure that the brace is securely inserted into the pedal arm. Repeat this action for the other pedal.**

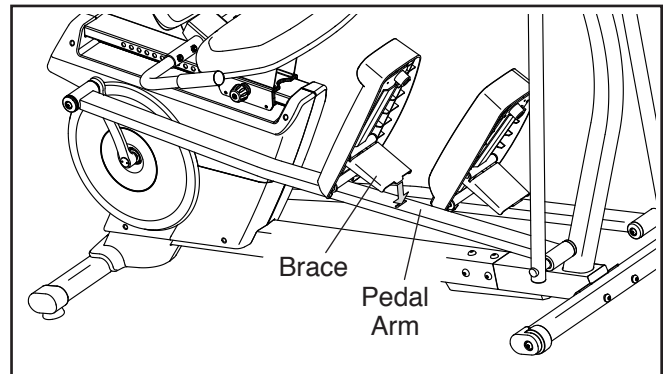

Then, adjust the seat forward or backward to the position that is the most comfortable. To adjust the seat, loosen the carriage knob and pull it outward, slide the seat to the desired position, and then release the carriage knob into an adjustment hole on the frame. **Make sure that the carriage knob is securely inserted into an adjustment hole.** Then, tighten the carriage knob.

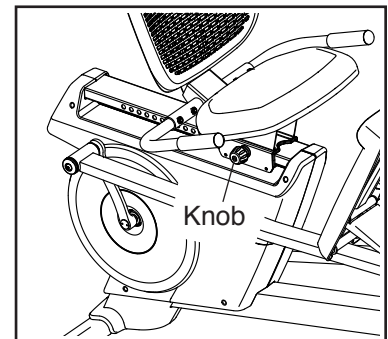

CONSOLE DIAGRAM

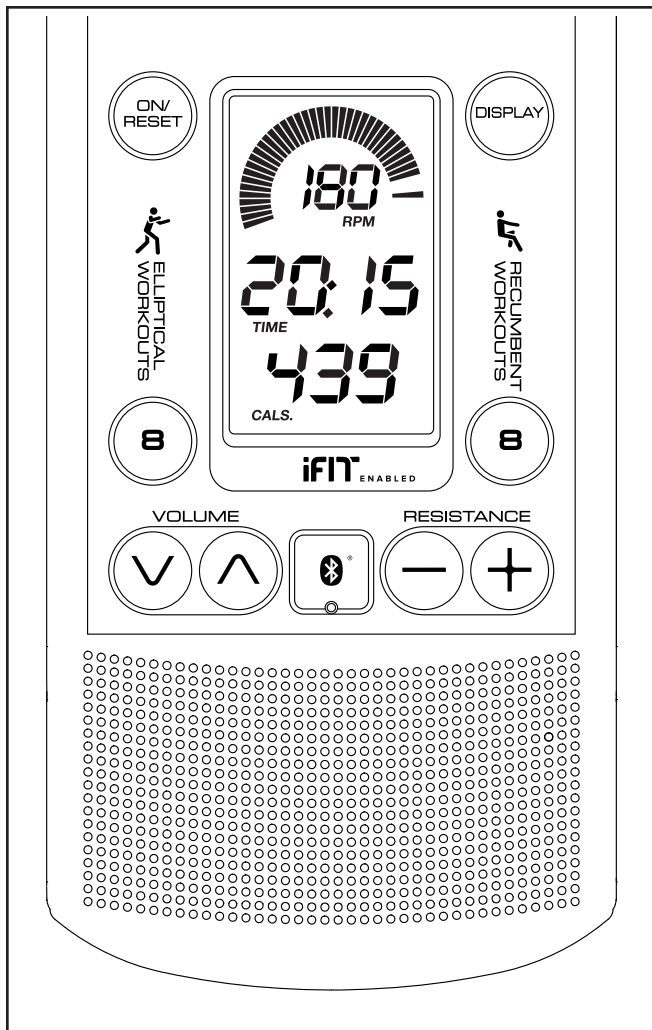

FEATURES OF THE CONSOLE

The advanced console offers an array of features designed to make your workouts more effective and enjoyable.

When you use the manual mode of the console, you can change the resistance of the pedals with the touch of a button. As you exercise, the console will provide continuous exercise feedback. You can even measure your heart rate using the handgrip heart rate monitor or a compatible heart rate monitor. **See page 21 for information about purchasing an optional chest heart rate monitor.**

You can also connect your smart device to the console and use an iFit® app to record and track your workout information.

The console also offers sixteen preset workouts—eight workouts for the recumbent bike mode and eight workouts for the elliptical mode. Each workout automatically changes the resistance of the pedals and prompts you to vary your pedaling speed while guiding you through an effective workout.

You can even connect your personal audio player to the console sound system and listen to your favorite music or audio books while you exercise.

To use the manual mode, see page 18. To use the sound system, see page 19. To use a preset workout, see page 20. To connect your smart device to the console, see page 21. To connect your heart rate monitor to the console, see page 21. To use the settings mode, see page 22.

Note: Before using the console, make sure that batteries are installed (see assembly step 12 on page 11). If there is a sheet of plastic on the display, remove the plastic.

HOW TO USE THE MANUAL MODE

1. Turn on the console.

Press any button or begin pedaling to turn on the console.

When you turn on the console, the displays will turn on, a tone will sound, and the console will be ready for use.

2. Select the manual mode.

When you turn on the console, the manual mode will be selected automatically.

If you have selected a workout, reselect the manual mode by pressing the On/Reset button.

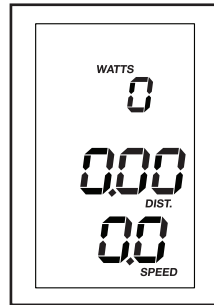

3. Begin pedaling and change the resistance of the pedals as desired.

As you pedal, change the resistance of the pedals by pressing the Resistance increase and decrease buttons.

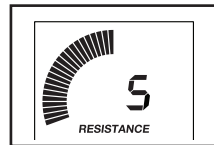

Note: After you press the buttons, it will take a moment for the pedals to reach the selected resistance level.

4. Follow your progress with the displays.

The speed meter—This display will provide a visual representation of your pedaling speed. As you increase or decrease your pedaling speed, bars will appear or disappear in the speed meter.

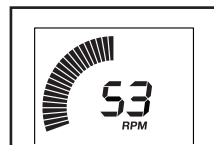

Note: During a preset workout, this display will show a target speed zone for each segment of the workout.

The upper display—This display will show your pedaling speed in revolutions per minute (RPM) and your power output in watts. The display will change every few seconds.

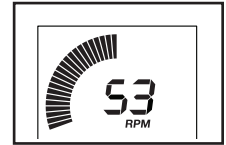

This display will also show the resistance level of the pedals for a few seconds each time the resistance level changes.

This display will also show your heart rate (BPM) when you use the handgrip heart rate monitor or a compatible heart rate monitor (see step 5).

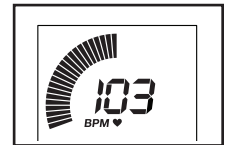

The center display—This display will show the distance (Dist.) you have pedaled in miles or kilometers and the elapsed time. The display will change every few seconds.



Note: During a preset workout, the display will show the time remaining in the workout instead of the elapsed time.

The lower display—This display will show your pedaling speed in miles per hour or kilometers per hour and the approximate number of calories (Cals.) you have burned. The display will change every few seconds.

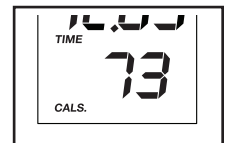

To select an information mode for continuous display, press the Display button repeatedly until the desired information is shown in the display.

To return to alternating the information that is shown in the displays, press the Display button repeatedly until the word SCAN appears in the center display.

Change the volume level of the console by pressing the Volume increase and decrease buttons.



To pause the console, stop pedaling. When the console is paused, the displays will pause. To continue your workout, simply resume pedaling.

To reset the displays to zero, press the On/Reset button.

Note: The console can show pedaling speed and distance in either miles or kilometers. To change the unit of measurement, see THE SETTINGS MODE on page 22.

5. Measure your heart rate if desired.

You can measure your heart rate using either the handgrip heart rate monitor or a compatible heart rate monitor. For information about purchasing an optional chest heart rate monitor, see page 21.

The console is compatible with all BLUETOOTH® Smart heart rate monitors. To connect your heart rate monitor to the console, see page 21.

Note: If you use both heart rate monitors at the same time, the BLUETOOTH Smart heart rate monitor will have priority.

If there are sheets of plastic on the metal contacts on the handgrip heart rate monitor, remove the plastic. In addition, make sure that your hands are clean. To measure your heart rate, hold the handgrip heart rate monitor with your palms resting against the contacts. Avoid moving your hands or gripping the contacts tightly.

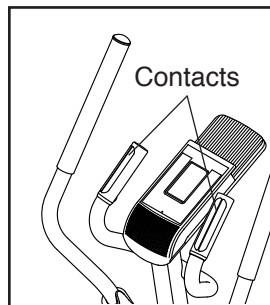

When your pulse is detected, your heart rate will be shown in the upper display. **For the most accurate heart rate reading, hold the contacts for at least 15 seconds.**

If your heart rate is not shown, make sure that your hands are positioned as described. Be careful not to move your hands excessively or to squeeze the contacts tightly. For optimal performance, clean the contacts using a soft cloth; **never use alcohol, abrasives, or chemicals to clean the contacts.**

6. When you are finished exercising, the console will turn off automatically.

If the pedals do not move for several seconds, a series of tones will sound, the console will pause, and displays will pause.

If the pedals do not move for several minutes, the console will turn off and the displays will be reset.

HOW TO USE THE SOUND SYSTEM

To play music or audio books through the console sound system while you exercise, plug a 3.5 mm male to 3.5 mm male audio cable (not included) into the jack on the console and into a jack on your personal audio player; **make sure that the audio cable is fully plugged in. Note: To purchase an audio cable, see your local electronics store.**

Next, press the play button on your personal audio player. Adjust the volume level using the volume increase and decrease buttons on the console or the volume control on your personal audio player.



HOW TO USE A PRESET WORKOUT

1. Turn on the console.

Press any button or begin pedaling to turn on the console.

When you turn on the console, the displays will turn on, a tone will sound, and the console will be ready for use.

2. Select a preset workout.

When you select a Recumbent preset workout, you must adjust the hybrid trainer to the recumbent bike mode for the console to provide accurate feedback (see HOW TO USE THE RECUMBENT BIKE MODE on page 16).

When you select an Elliptical preset workout, you must adjust the hybrid trainer to the elliptical mode for the console to provide accurate feedback (see HOW TO USE THE ELLIPTICAL MODE on page 15).

To select a preset workout, press the Elliptical Workouts or Recumbent Workouts button repeatedly until the number of the desired workout appears in the lower display. The duration of the workout will appear in the center display.

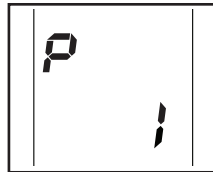

3. Start the workout.

Begin pedaling to start the workout.

Each workout is divided into one-minute segments. One resistance level and one target speed are programmed for each segment. Note: The same resistance level and/or target speed may be programmed for consecutive segments.

At the end of each segment of the workout, a series of tones will sound. The resistance level for the next segment will appear in the upper display for a few seconds to alert you. The resistance of the pedals will then change.

The speed meter will show two flashing bars that represent the target speed zone for the segment; the target speed zone includes a range of speeds that are within a few RPMs of the target speed for the segment. The solid bars represent your actual pedaling speed.

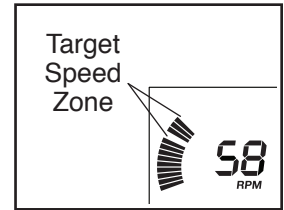

As you exercise, keep your pedaling speed within the target speed zone for the current segment by increasing or decreasing your pedaling speed or by increasing or decreasing the resistance of the pedals.

IMPORTANT: The target speed is intended only to provide motivation. Make sure to pedal at a speed and a resistance level that is comfortable for you.

If the resistance level for the current segment is too high or too low, you can manually override the setting by pressing the Resistance buttons.

IMPORTANT: When the current segment of the workout ends, the pedals will automatically adjust to the resistance level programmed for the next segment.

If you stop pedaling for several seconds, a series of tones will sound and the workout will pause.

To restart the workout, simply resume pedaling. The workout will continue until the last segment of the workout ends.

4. Follow your progress with the displays.

See step 4 on page 18.

5. Measure your heart rate if desired.

See step 5 on page 19.

6. When you are finished exercising, the console will turn off automatically.

See step 6 on page 19.

THE OPTIONAL CHEST HEART RATE MONITOR

Whether your goal is to burn fat or to strengthen your cardiovascular system, the key to achieving the best results is to maintain the proper heart rate during your workouts. The optional chest heart rate monitor will enable you to continuously monitor your heart rate while you exercise, helping you to reach your personal fitness goals. **To purchase a chest heart rate monitor, please see the front cover of this manual.**

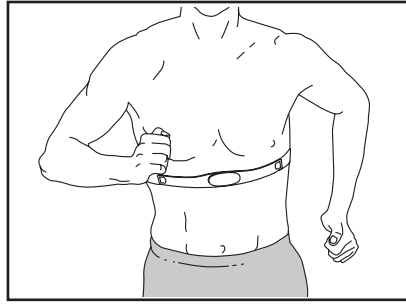

Note: The console is compatible with all BLUETOOTH Smart heart rate monitors.

HOW TO CONNECT YOUR SMART DEVICE TO THE CONSOLE

The console supports BLUETOOTH connections to smart devices via the iFit app and to compatible heart rate monitors. Note: Other BLUETOOTH connections are not supported.

1. Download and install the iFit app on your smart device.

On your iOS® or Android™ smart device, open the App StoreSM or the Google Play™ store, search for the free iFit app, and then install the app on your smart device. **Make sure that the BLUETOOTH option is enabled on your smart device.**

Then, open the iFit app and follow the instructions to set up an iFit account and customize settings.

2. Connect your smart device to the console.

Follow the instructions in the iFit app to connect your smart device to the console.

When a connection is established, the LED on the console will flash blue. Press the Bluetooth Smart button on the console to confirm the connection; the LED on the console will then turn solid blue.

3. Record and track your workout information.

Follow the instructions in the iFit app to record and track your workout information.

4. Disconnect your smart device from the console if desired.

To disconnect your smart device from the console, press and hold the Bluetooth Smart button on the console for 5 seconds.

Note: All BLUETOOTH connections between the console and other devices (including any smart devices, heart rate monitors, and so forth) will be disconnected.

HOW TO CONNECT YOUR HEART RATE MONITOR TO THE CONSOLE

The console is compatible with all BLUETOOTH Smart heart rate monitors.

To connect your BLUETOOTH Smart heart rate monitor to the console, press the Bluetooth Smart button on the console. When a connection is established, the LED on the console will flash red twice.

Note: If there is more than one compatible heart rate monitor near the console, the console will connect to the heart rate monitor with the strongest signal.

To disconnect your heart rate monitor from the console, press and hold the Bluetooth Smart button on the console for 5 seconds.

Note: All BLUETOOTH connections between the console and other devices (including any smart devices, heart rate monitors, and so forth) will be disconnected.

THE SETTINGS MODE

The console features a settings mode that allows you to select a unit of measurement for the console and to view console usage information.

To select the settings mode, press and hold down the On/Reset button until the settings mode information appears in the display.

The console can show pedaling speed and distance in either miles or kilometers. The upper display will show the selected unit of measurement. An E for English miles or an M for metric kilometers will appear in the display. To change the unit of measurement, press the Elliptical Workouts button repeatedly.

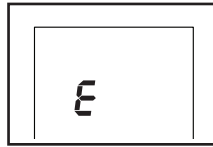

Note: When you replace the batteries, it may be necessary to reselect the unit of measurement.

Press the Recumbent Workouts button to view the total distance and the total time. The center display will show the total time (in hours) that the console has been used since the hybrid trainer was purchased. The lower display will show the total distance (in miles or kilometers) that the hybrid trainer has been pedaled.

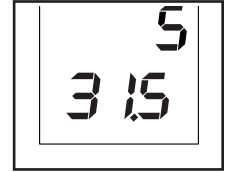

To exit the settings mode, press the Recumbent Workouts button repeatedly.

FCC INFORMATION

This equipment has been tested and found to comply with the limits for a Class B digital device, pursuant to part 15 of the FCC Rules. These limits are designed to provide reasonable protection against harmful interference in a residential installation. This equipment generates, uses, and can radiate radio frequency energy and, if not installed and used in accordance with the instructions, may cause harmful interference to radio communications. However, there is no guarantee that interference will not occur in a particular installation. If this equipment does cause harmful interference to radio or television reception, which can be determined by turning the equipment off and on, try to correct the interference by one or more of the following measures:

- Reorient or relocate the receiving antenna.
- Increase the separation between the equipment and the receiver.
- Connect the equipment into an outlet on a circuit different from that to which the receiver is connected.
- Consult the dealer or an experienced radio/TV technician for help.

FCC CAUTION: To assure continued compliance, use only shielded interface cables when connecting to computer or peripheral devices. Changes or modifications not expressly approved by the party responsible for compliance could void the user's authority to operate this equipment.

MAINTENANCE AND TROUBLESHOOTING

MAINTENANCE

Regular maintenance is important for optimal performance and to reduce wear. Inspect and properly tighten all parts each time the hybrid trainer is used. Replace any worn parts immediately.

To clean the hybrid trainer, use a damp cloth and a small amount of mild soap. **IMPORTANT: To avoid damage to the console, keep liquids away from the console and keep the console out of direct sunlight.**

CONSOLE TROUBLESHOOTING

Most console problems are the result of low batteries. To replace the batteries, see assembly step 12 on page 11.

If the console does not display your heart rate when you use the handgrip heart rate monitor, see step 5 on page 19.

HOW TO ADJUST THE REED SWITCH

If the console does not display correct feedback, the reed switch should be adjusted.

To adjust the reed switch, first remove the two M4 x 16mm Screws (84) from the Rear Access Cover (26), and then remove the Rear Access Cover.

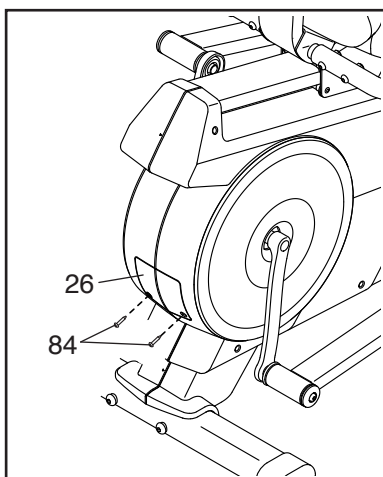

Next, locate the Reed Switch (60). Slightly loosen the two M4 x 16mm Screws (84).

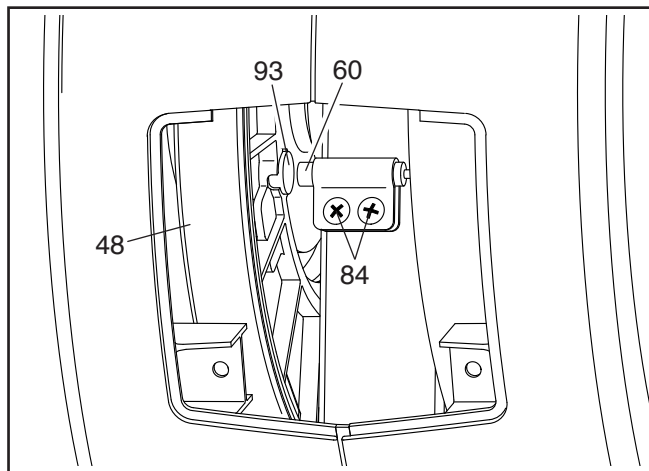

Next, rotate the Large Pulley (48) until a Pulley Magnet (93) is aligned with the Reed Switch (60). Slide the Reed Switch slightly toward or away from the Pulley Magnet. Then, retighten the M4 x 16mm Screws (84).

Rotate the Large Pulley (48) for a moment. Repeat these actions until the console displays correct feedback.

When the reed switch is correctly adjusted, reattach the rear access cover.

HOW TO ADJUST THE DRIVE BELT

If you can feel the pedals slip while you are pedaling, even when the resistance is adjusted to the highest level, the drive belt may need to be adjusted.

To adjust the drive belt, first remove the M4 x 16mm Screw (84) from the Side Access Cover (21), and then remove the Side Access Cover by moving it in the direction shown by the arrow.

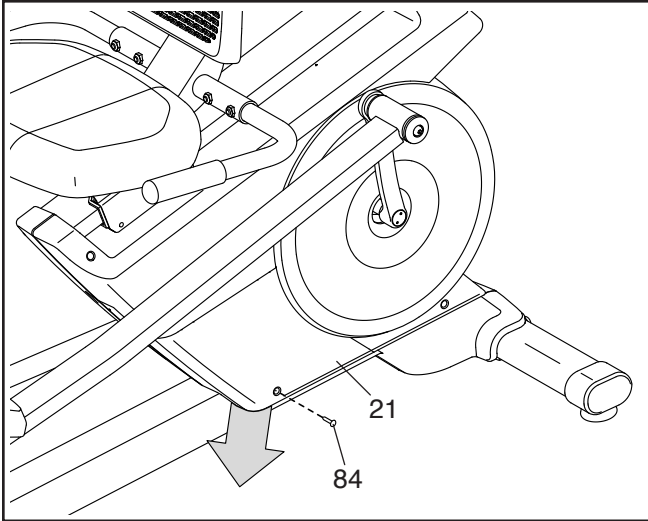

Next, loosen the M10 x 55mm Shoulder Bolt (99). Then, tighten the M8 Locknut (68) until the Drive Belt (64) is tight.

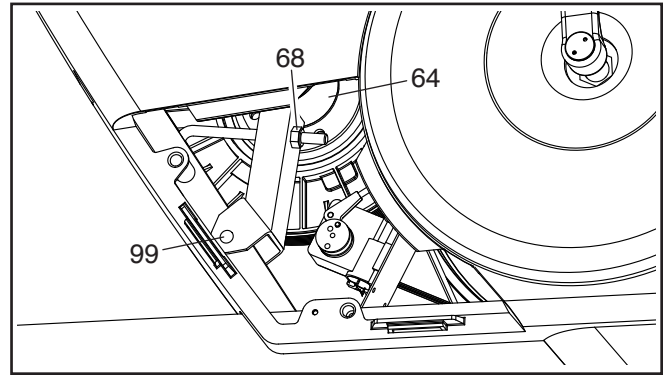

When the Drive Belt (64) is tight, tighten the M10 x 55mm Shoulder Bolt (99). Then, reattach the side access cover.

EXERCISE GUIDELINES

⚠️ WARNING: Before beginning this or any exercise program, consult your physician. This is especially important for persons over age 35 or persons with pre-existing health problems.

The heart rate monitor is not a medical device. Various factors may affect the accuracy of heart rate readings. The heart rate monitor is intended only as an exercise aid in determining heart rate trends in general.

These guidelines will help you to plan your exercise program. For detailed exercise information, obtain a reputable book or consult your physician. Remember, proper nutrition and adequate rest are essential for successful results.

EXERCISE INTENSITY

Whether your goal is to burn fat or to strengthen your cardiovascular system, exercising at the proper intensity is the key to achieving results. You can use your heart rate as a guide to find the proper intensity level. The chart below shows recommended heart rates for fat burning and aerobic exercise.

165	155	145	140	130	125	115	❤️
145	138	130	125	118	110	103	❤️
125	120	115	110	105	95	90	❤️
<hr/>							
20	30	40	50	60	70	80	

To find the proper intensity level, find your age at the bottom of the chart (ages are rounded off to the nearest ten years). The three numbers listed above your age define your “training zone.” The lowest number is the heart rate for fat burning, the middle number is the heart rate for maximum fat burning, and the highest number is the heart rate for aerobic exercise.

Burning Fat—To burn fat effectively, you must exercise at a low intensity level for a sustained period of time. During the first few minutes of exercise, your body uses carbohydrate calories for energy. Only after the first few minutes of exercise does your body begin to use stored fat calories for energy. If your goal is to burn fat, adjust the intensity of your exercise until your heart rate is near the lowest number in your training zone. For maximum fat burning, exercise with your heart rate near the middle number in your training zone.

Aerobic Exercise—If your goal is to strengthen your cardiovascular system, you must perform aerobic exercise, which is activity that requires large amounts of oxygen for prolonged periods of time. For aerobic exercise, adjust the intensity of your exercise until your heart rate is near the highest number in your training zone.

WORKOUT GUIDELINES

Warming Up—Start with 5 to 10 minutes of stretching and light exercise. A warm-up increases your body temperature, heart rate, and circulation in preparation for exercise.

Training Zone Exercise—Exercise for 20 to 30 minutes with your heart rate in your training zone. (During the first few weeks of your exercise program, do not keep your heart rate in your training zone for longer than 20 minutes.) Breathe regularly and deeply as you exercise; never hold your breath.

Cooling Down—Finish with 5 to 10 minutes of stretching. Stretching increases the flexibility of your muscles and helps to prevent post-exercise problems.

EXERCISE FREQUENCY

To maintain or improve your condition, complete three workouts each week, with at least one day of rest between workouts. After a few months of regular exercise, you may complete up to five workouts each week, if desired. Remember, the key to success is to make exercise a regular and enjoyable part of your everyday life.

SUGGESTED STRETCHES

The correct form for several basic stretches is shown at the right. Move slowly as you stretch; never bounce.

1. Toe Touch Stretch

Stand with your knees bent slightly and slowly bend forward from your hips. Allow your back and shoulders to relax as you reach down toward your toes as far as possible. Hold for 15 counts, then relax. Repeat 3 times. Stretches: Hamstrings, back of knees and back.

2. Hamstring Stretch

Sit with one leg extended. Bring the sole of the opposite foot toward you and rest it against the inner thigh of your extended leg. Reach toward your toes as far as possible. Hold for 15 counts, then relax. Repeat 3 times for each leg. Stretches: Hamstrings, lower back and groin.

3. Calf/Achilles Stretch

With one leg in front of the other, reach forward and place your hands against a wall. Keep your back leg straight and your back foot flat on the floor. Bend your front leg, lean forward and move your hips toward the wall. Hold for 15 counts, then relax. Repeat 3 times for each leg. To cause further stretching of the achilles tendons, bend your back leg as well. Stretches: Calves, achilles tendons and ankles.

4. Quadriceps Stretch

With one hand against a wall for balance, reach back and grasp one foot with your other hand. Bring your heel as close to your buttocks as possible. Hold for 15 counts, then relax. Repeat 3 times for each leg. Stretches: Quadriceps and hip muscles.

5. Inner Thigh Stretch

Sit with the soles of your feet together and your knees outward. Pull your feet toward your groin area as far as possible. Hold for 15 counts, then relax. Repeat 3 times. Stretches: Quadriceps and hip muscles.

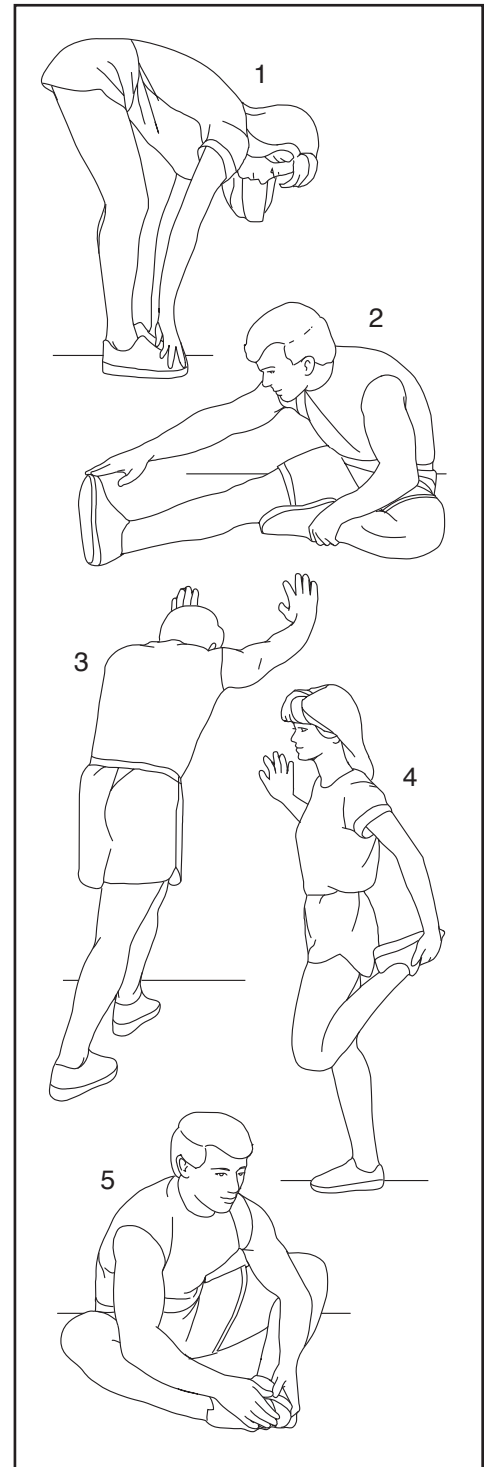

PART LIST

Model No. 831.23890.0 R0816A

Key No.	Qty.	Description	Key No.	Qty.	Description
1	1	Frame	51	6	Crank Bearing
2	1	Upright	52	1	Bearing Spacer
3	1	Pivot Bracket	53	1	Crank Collar
4	1	Console	54	1	Idler Axle
5	1	Front Stabilizer	55	1	Idler Bolt
6	1	Rear Stabilizer	56	2	Idler Bushing
7	1	Right Upper Body Arm	57	1	Idler Bracket
8	1	Right Pivot Leg	58	1	Small Pulley
9	1	Right Pedal Arm	59	1	Flywheel
10	1	Left Upper Body Arm	60	1	Reed Switch/Wire
11	1	Left Pivot Leg	61	1	Seat Frame
12	1	Left Pedal Arm	62	2	Leveling Foot
13	1	Pivot Knob	63	1	Clamp
14	1	Accessory Tray	64	2	Drive Belt
15	2	Upper Body Grip	65	14	Pivot Bushing
16	2	Pulse Grip	66	1	Left Crank Bracket
17	2	Wheel Cap	67	1	Set Screw
18	2	Crank Cap	68	24	M8 Locknut
19	4	M10 x 80mm Screw	69	3	Crank Screw
20	1	Wire Cover	70	1	Right Pedal
21	1	Side Access Cover	71	1	Left Pedal
22	1	Left Shield	72	2	Pedal Plate
23	1	Right Shield	73	2	Bumper
24	2	Crank Arm	74	2	Pedal Brace
25	1	Pivot Cover	75	2	Upper Body Cap
26	1	Rear Access Cover	76	6	M10 x 20mm Screw
27	1	Backrest	77	1	M5 x 10mm Screw
28	1	Seat	78	2	Upper Body Cover
29	2	Seat Handlebar	79	2	Pivot Spacer
30	1	Right Crank Bracket	80	1	Pivot Axle
31	2	Seat Grip	81	2	Pivot Leg Cap
32	1	Seat Carriage	82	2	Wheel
33	2	Seat Handlebar Cap	83	6	Pivot Cover
34	1	Seat Carriage Bracket	84	31	M4 x 16mm Screw
35	2	Seat Carriage Bushing	85	4	Foot
36	1	Adjustment Pin	86	6	M8 x 14mm Shoulder Screw
37	1	Carriage Knob	87	7	M8 Washer
38	1	Carriage Knob Screw	88	2	M5 Nut
39	4	M6 x 10mm Bolt	89	2	M5 x 10mm Black Screw
40	12	M6 x 16mm Screw	90	5	M4 x 10mm Screw
41	2	Carriage Cap	91	2	M5 Washer
42	2	Stabilizer Cap	92	8	M8 x 20mm Bolt
43	1	C-magnet	93	2	Pulley Magnet
44	1	Resistance Motor	94	1	Upper Wire
45	1	Resistance Arm	95	4	M8 x 38mm Bolt
46	1	Resistance Disc	96	1	Main Wire
47	1	Resistance Block	97	4	M6 x 18mm Screw
48	2	Large Pulley	98	4	M6 x 35mm Screw
49	1	Crank	99	1	M10 x 55mm Shoulder Bolt
50	1	Weld Spacer	100	1	M8 Snap Ring

Key No.	Qty.	Description	Key No.	Qty.	Description
101	2	M10 x 54mm Shoulder Screw	109	2	M10 x 110mm Shoulder Bolt
102	6	M8 x 38mm Hex Bolt	110	8	M8 Split Washer
103	1	Left Pulse Wire	111	4	M6 Locknut
104	1	Right Pulse Wire	112	2	Clip Nut
105	2	M19 Snap Ring	*	–	User's Manual
106	6	M8 x 12mm Screw	*	–	Assembly Tool
107	2	M8 x 89mm Hex Shoulder Bolt	*	–	Grease Packet
108	1	M4 x 16mm Bright Screw			

Note: Specifications are subject to change without notice. For information about ordering replacement parts, see the back cover of this manual. **If a part is missing, call 1-888-533-1333.** *These parts are not illustrated.

EXPLODED DRAWING A

Model No. 831.23890.0 R0816A

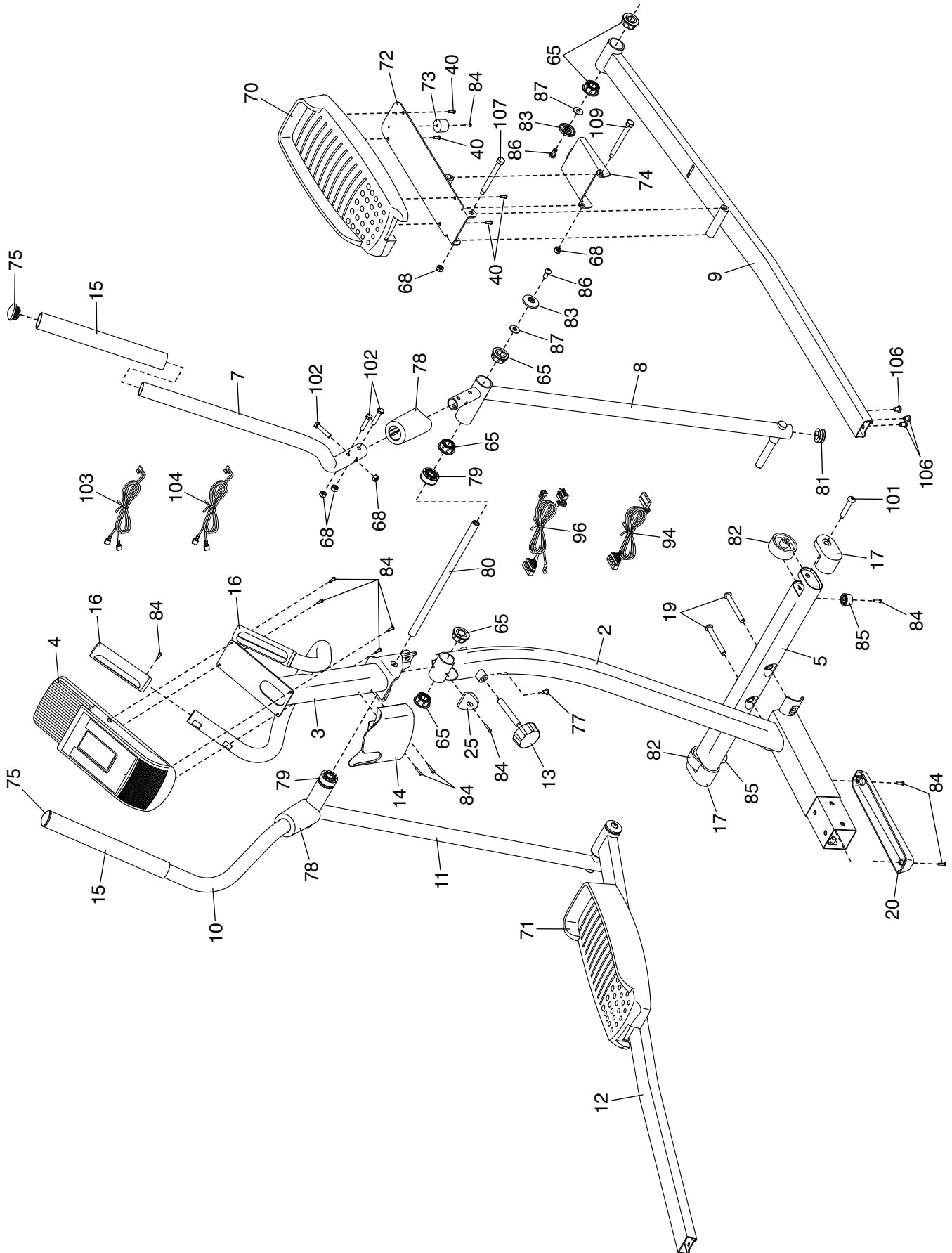

EXPLODED DRAWING B

Model No. 831.23890.0 R0816A

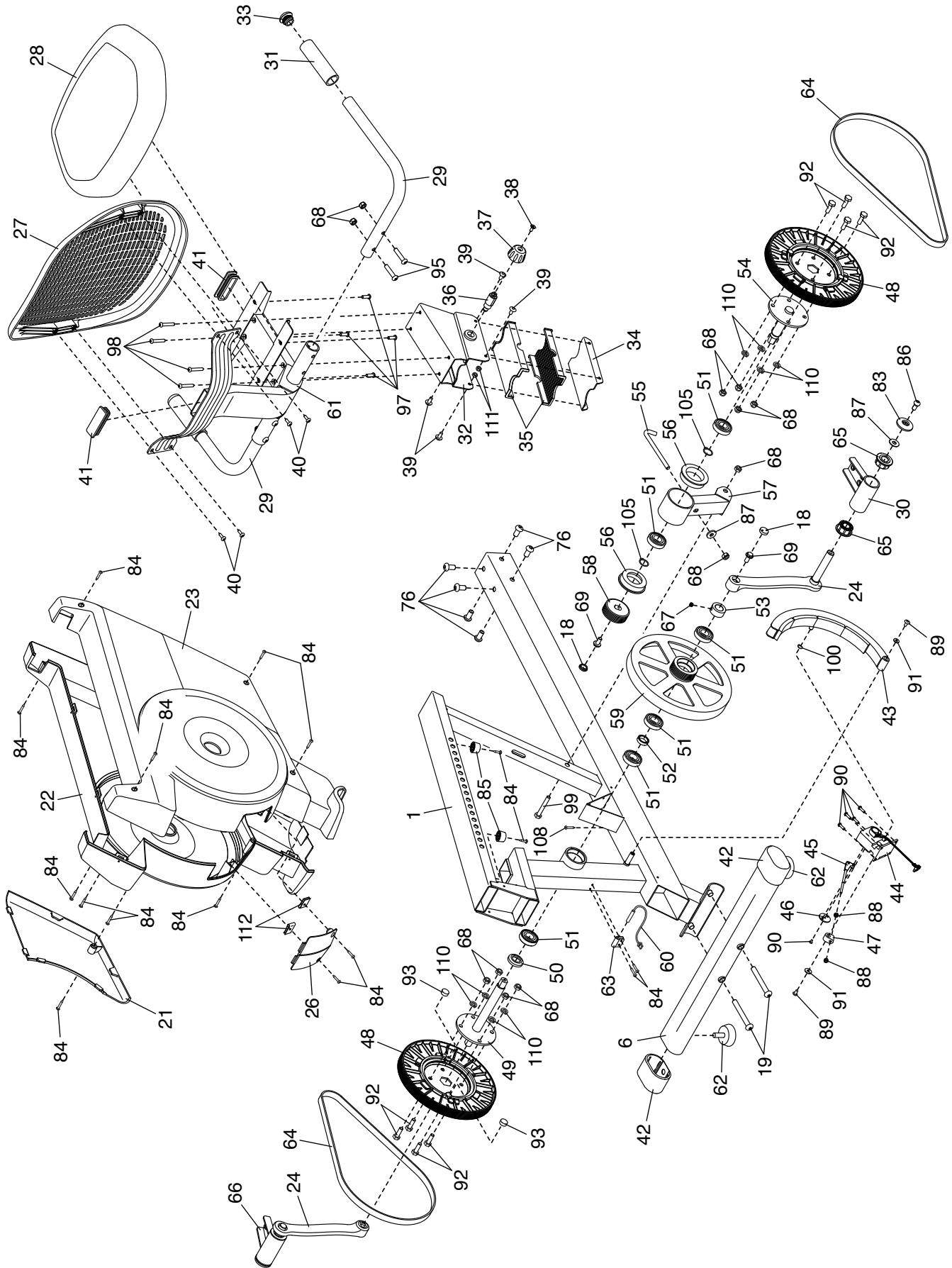

Get it fixed, at your home or ours!

Your Home

For repair—in **your home**—of **all** major brand appliances, lawn and garden equipment, or heating and cooling systems, **no matter who made it, no matter who sold it!**

For the replacement parts, accessories, and user's manuals that you need to do-it-yourself.

For Sears professional installation of home appliances and items like garage door openers and water heaters.

1-800-4-MY-HOME® (1-800-469-4663)

Call anytime, day or night (U.S.A. and Canada)

www.sears.com

www.sears.ca

Our Home

For repair of carry-in items like vacuums, lawn equipment, and electronics, call or go on-line for the location of your nearest **Sears Parts & Repair Center.**

1-800-488-1222 Call anytime, day or night (U.S.A. only)

www.sears.com

To purchase a protection agreement (U.S.A.) or maintenance agreement (Canada) on a product serviced by Sears:

1-800-827-6655 (U.S.A.)

1-800-361-6665 (Canada)

Para pedir servicio de reparación a domicilio, y para ordenar piezas:

1-888-SU-HOGAR® (1-888-784-6427)



® Registered Trademark / ™ Trademark / ™ Service Mark of Sears Brands, LLC
© Marca Registrada / ™ Marca de Fábrica / ™ Marca de Servicio de Sears Brands, LLC

90 DAY FULL WARRANTY

If this Sears Exerciser fails due to a defect in material or workmanship within 90 days of the date of purchase, call 1-800-4-MY-HOME® (1-800-469-4663) to arrange for free repair (or replacement if repair proves impossible). The frame is warranted for 5 years.

This warranty does not apply when the Exerciser is used commercially or for rental purposes.

This warranty gives you specific legal rights, and you may also have other rights which vary from state to state.

Sears, Roebuck and Co., Hoffman Estates, IL 60179