

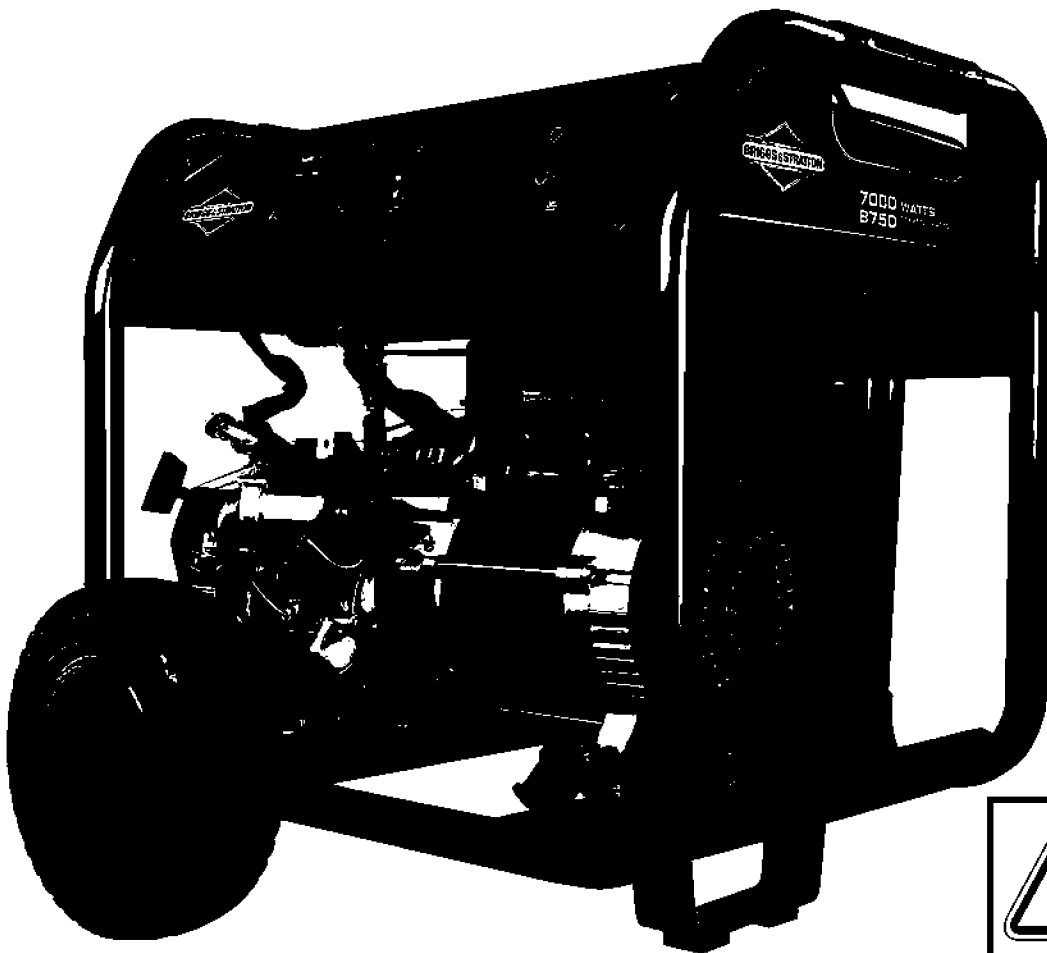

# Portable Generator Operator's Manual



This generator is certified in accordance with CSA (Canadian Standards Association) standard C22.2 No. 100-04 (motors and generators) and rated in accordance with PGMA (Portable Generator Manufacturers' Association) standard PGMA G200 (Standard for Testing and Validating Performance of Portable Generators).

**BRIGGS & STRATTON POWER PRODUCTS GROUP, LLC**  
**MILWAUKEE, WISCONSIN, U.S.A.**

Manual No. 80010760 Revision -

**Thank you** for purchasing this quality-built Briggs & Stratton® generator. We are pleased that you've placed your confidence in the Briggs & Stratton brand. When operated and maintained according to the instructions in this manual, your Briggs & Stratton generator will provide many years of dependable service.

**This manual contains** safety information to make you aware of the hazards and risks associated with generator products and how to avoid them. This generator is designed and intended only for supplying electrical power for operating compatible electrical lighting, appliances, tools and motor loads, and is not intended for any other purpose. It is important that you read and understand these instructions thoroughly before attempting to start or operate this equipment. **Save these original instructions for future reference.**

**This generator requires final assembly before use.** Refer to the *Assembly* section of this manual for instructions on final assembly procedures. Follow the instructions completely.

## Where to Find Us

You never have to look far to find Briggs & Stratton support and service for your generator. Consult your Yellow Pages. There are over 30,000 Briggs & Stratton authorized service dealers worldwide who provide quality service. You can also contact Briggs & Stratton Customer Service by phone at **(800) 743-4115**, or on the Internet at **BRIGGSandSTRATTON.COM**.

## Generator

Model Number

Revision

Serial Number

## Engine

Model Number

Type Number

Code Number

## Date Purchased

Copyright © 2014. Briggs & Stratton Power Products Group, LLC  
Milwaukee, WI, USA. All rights reserved.

BRIGGS & STRATTON POWER PRODUCTS is a registered  
trademark of Briggs & Stratton Corporation  
Milwaukee, WI, USA

# Safe Operation Checklist

Safe operation of the portable generator requires the completion of the following tasks:

## Carbon Monoxide (CO) Alarm

- Carbon monoxide (CO) alarm(s) in working order.

## Smoke Alarm

- Smoke alarm(s) in working order.

## Generator Location

- Generator placed in a Carbon Monoxide (CO) safe zone. See *Generator Location to reduce the Risk of Carbon Monoxide Poisoning*.
- Generator placed in a fire safe zone. See *Generator Location to reduce the Risk of Fire*.
- Generator located on flat and level surface.

## Oil and Fuel

- Engine has proper oil level. See *Verify Engine Oil Level*.
- Fuel tank filled at or below baffle. See *Add Fuel*.
- Inspect fuel lines, tank, cap and fittings each time before using generator. DO NOT use if fuel leak or damage is found.

## Electrical

- When connecting to a buildings electrical system install listed transfer equipment. See *Connecting to a Building's Electrical System*.
- Electrical cords are rated for intended loads. See *Cord Sets and Receptacles*.
- Electrical cords do not run through doorways, windows, holes in ceilings, walls or floors.
- Inspect electrical cords thoroughly before each use. DO NOT use if damaged.
- All labeled electrical cord safeties are understood and being followed.

## Operation

- Start engine. See *Starting the Engine*.

# Table of Contents

<b>Safe Operation Checklist</b> . . . . .	<b>3</b>
<b>Operator Safety</b> . . . . .	<b>5</b>
Safety Labels . . . . .	5
Equipment Description . . . . .	7
Important Safety Information . . . . .	7
<b>Assembly</b> . . . . .	<b>10</b>
Unpack Generator . . . . .	10
Install Wheel Kit . . . . .	10
Attach Negative Battery Cable . . . . .	10
Verify Engine Oil Level . . . . .	11
Add Fuel . . . . .	11
System Ground . . . . .	11
Connecting to a Building's Electrical System . . . . .	11
Portable Generator Location . . . . .	12
<b>Features and Controls</b> . . . . .	<b>15</b>
Cord Sets and Receptacles . . . . .	16
Battery Charger . . . . .	16
<b>Operation</b> . . . . .	<b>17</b>
Starting the Engine . . . . .	17
Connecting Electrical Loads . . . . .	18
Stopping the Engine . . . . .	18
Low Oil Shutdown . . . . .	18
Cold Weather Operation . . . . .	18
Don't Overload Generator . . . . .	20
<b>Maintenance</b> . . . . .	<b>21</b>
Maintenance Schedule . . . . .	21
Generator Maintenance . . . . .	21
Battery Maintenance . . . . .	21
Fuel Valve Maintenance . . . . .	22
Engine Maintenance . . . . .	22
Storage . . . . .	25
<b>Troubleshooting</b> . . . . .	<b>26</b>
Schematic - Model 030470 (7000 Watt) . . . . .	28
Schematic - Model 030471 (8000 Watt) . . . . .	29
<b>Warranty</b> . . . . .	<b>30</b>
Generator Owner Warranty . . . . .	30
<b>Specifications</b> . . . . .	<b>32</b>
Product Specifications . . . . .	32
Common Service Parts . . . . .	32

# Operator Safety

## Safety Labels

The generator safety labels shown below and on the next page are placed on your portable generator to draw attention to potential safety hazards.

**⚠ DANGER**

L'utilisation d'une génératrice à l'intérieur peut vous tuer en quelques minutes

L'échappement contient du monoxyde de carbone, un gaz toxique que vous ne pouvez pas voir ou sentir

Ne jamais utiliser à la maison ou dans des espaces partiellement clos, tels que les garages

Utiliser seulement à l'extérieur et loin des fenêtres, des portes et des bouches d'air

80005254

**⚠ DANGER**

Using a generator indoors CAN KILL YOU IN MINUTES.

Generator exhaust contains carbon monoxide. This is a poison you cannot see or smell.

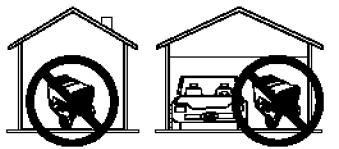

**NEVER** use inside a home or garage, **EVEN IF** doors and windows are open.

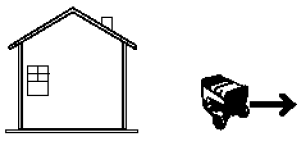

Only use **OUTSIDE** and far away from windows, doors, and vents.

202997

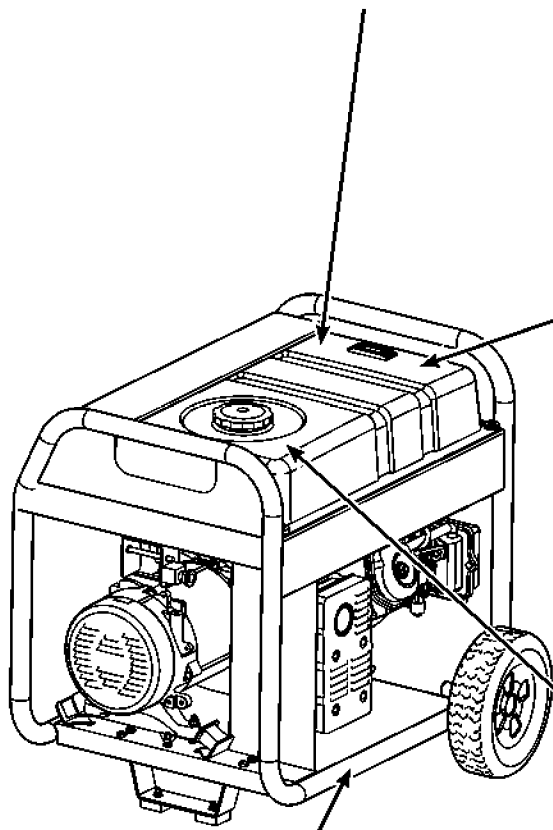

**⚠ Fire Hazard.** Fuel is flammable which could cause burns resulting in death or serious injury. **DO NOT** fill fuel above baffle. Always allow space for fuel expansion.



**Risque d'incendie.** L'essence est inflammable et peut causer des blessures entraînant la mort ou des blessures graves. **NE PAS** remplir le réservoir au-dessus du niveau du déflecteur. Toujours maintenir un espace vide suffisant pour permettre au carburant de se dilater.

80005249

**⚠ Fire hazard.** Hot exhaust and reflective exhaust gases could cause burns and fires resulting in death or serious injury. Keep at least 5 ft. (1.5 m) clearance from any combustibles or structures, including overhead.



**Risque d'incendie.** Les gaz d'échappement et les gaz d'échappement réfléchis peuvent causer des brûlures et des feux entraînant la mort ou des blessures graves. Demeurez à au moins 1,5 m (5 pi) de tous combustibles ou structures, incluant au-dessus de vous.

80005251

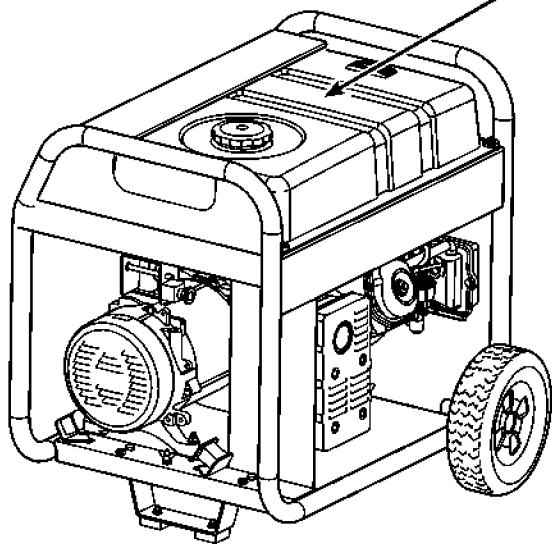

Failure to read and follow the operator's manual, all warnings and operating instructions could result in death or serious injury.

Prière de lire et suivre toutes les directives du manuel d'utilisation, sans quoi la mort, des blessures graves pourraient survenir.



**Poisonous Gas Hazard.**  
Engine exhaust contains carbon monoxide, a poisonous gas that could kill you in minutes.

You CANNOT smell it, see it, or taste it.  
• Operate this product ONLY outside far away from windows, doors and vents.  
• Install battery operated carbon monoxide alarms in home.

**Risque d'empoisonnement au gaz.**  
Les émanations du moteur contiennent du monoxyde de carbone, un gaz poison pouvant vous tuer en l'espace de quelques minutes. Il vous est IMPOSSIBLE de le sentir, de le voir, ou de le goûter.  
• Mettez ce produit en marche SEULEMENT à l'extérieur et loin des fenêtres, portes ou entrées de ventilation.  
• Installez chez vous une alarme détectant le monoxyde de carbone.



**Fire Hazard.**  
Fuel and its vapors are flammable which could cause burns resulting in death or serious injury.

• Turn engine off and let it cool at least 2 minutes before refueling.  
• Never add fuel to a hot or running generator.

**Risque d'incendie.**  
L'essence et ses vapeurs sont inflammables et peuvent causer des brûlures entraînant la mort ou des blessures graves.  
• Éteignez le moteur et laissez-le refroidir pendant au moins 2 minutes avant d'y mettre de l'essence.  
• N'ajoutez jamais d'essence dans une génératrice en fonction ou chaude.



**Shock Hazard.**  
Generator voltage could cause electrical shock resulting in death or serious injury.

• Transfer switch must be used when connecting to a building's electrical system.  
• Do not run generator in rain or wet weather.

**Risque de chocs électriques.**  
Le voltage de la génératrice peut causer des chocs électriques entraînant la mort ou des blessures graves.

• L'interrupteur de transfert doit être utilisé lorsque vous connectez l'appareil au système électrique d'un édifice.  
• Ne faites pas fonctionner la génératrice sous la pluie ou dans un climat humide.



**Burn Hazard.**  
Muffler area could cause burns.  
• Do not touch hot parts  
• Avoid hot exhaust gases.

**Risques de brûlures.**  
La zone autour du pot d'échappement pourrait être chaude et causer des brûlures.

• Ne touchez pas aux parties chaudes.  
• Évitez les gaz d'échappement chauds.

80006250

## Equipment Description



**Read this manual carefully and become familiar with your generator. Know its applications, its limitations and any hazards involved.**

The generator is an engine-driven, revolving field, alternating current (AC) generator equipped with a voltage regulator. The voltage regulator is designed to automatically maintain a constant output voltage level. It was designed to supply electrical power for operating compatible electrical lighting, appliances, tools and motor loads. The generator's revolving field is driven at about 3600 rpm by a single cylinder engine.

**NOTICE** Exceeding generator's wattage/amperage capacity could damage generator and/or electrical devices connected to it.

- DO NOT exceed the generator's wattage/amperage capacity. See *Don't Overload Generator* in the *Operation* section.

Every effort has been made to ensure that the information in this manual is both accurate and current. However, the manufacturer reserves the right to change, alter or otherwise improve the generator and this documentation at any time without prior notice.

The Emission Control System for this generator is warranted for standards set by the Environmental Protection Agency and the California Air Resources Board.

This spark ignition system complies with the Canadian standard ICES-002.

## Important Safety Information

The manufacturer cannot possibly anticipate every possible circumstance that might involve a hazard. The warnings in this manual, and the tags and decals affixed to the unit are, therefore, not all-inclusive. If you use a procedure, work method or operating technique that the manufacturer does not specifically recommend, you must satisfy yourself that it is safe for you and others. You must also make sure that the procedure, work method or operating technique that you choose does not render the generator unsafe.

### Safety Symbols and Meanings



Toxic Fumes



Kickback



Electrical Shock



Fire



Explosion



Operator's Manual



Moving Parts



Flying Objects



Hot Surface

**⚠** The safety alert symbol indicates a potential personal injury hazard. A signal word (**DANGER**, **WARNING**, or **CAUTION**) is used with the alert symbol to designate a degree or level of hazard seriousness. A safety symbol may be used to represent the type of hazard. The signal word **NOTICE** is used to address practices not related to personal injury.

**⚠ DANGER** indicates a hazard which, if not avoided, *will* result in death or serious injury.

**⚠ WARNING** indicates a hazard which, if not avoided, *could* result in death or serious injury.

**⚠ CAUTION** indicates a hazard which, if not avoided, *could* result in minor or moderate injury.

**NOTICE** address practices not related to personal injury.

## ⚠ DANGER

Using a generator indoors **CAN KILL YOU IN MINUTES.**

Generator exhaust contains carbon monoxide. This is a poison you cannot see or smell.

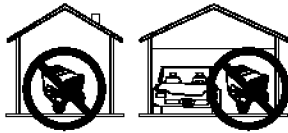

**NEVER use inside a home or garage, EVEN IF doors and windows are open.**

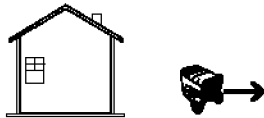

**Only use OUTSIDE and far away from windows, doors, and vents.**

**⚠ WARNING POISONOUS GAS HAZARD.** Engine exhaust contains carbon monoxide, a poisonous gas that could kill you in minutes. You **CANNOT** smell it, see it, or taste it. Even if you do not smell exhaust fumes, you could still be exposed to carbon monoxide gas.

- Operate this product **ONLY** outside far away from windows, doors and vents to reduce the risk of carbon monoxide gas from accumulating and potentially being drawn towards occupied spaces.
- Install battery-operated carbon monoxide alarms or plug-in carbon monoxide alarms with battery back-up according to the manufacturer's instructions. Smoke alarms cannot detect carbon monoxide gas.
- **DO NOT** run this product inside homes, garages, basements, crawlspaces, sheds, or other partially-enclosed spaces even if using fans or opening doors and windows for ventilation. Carbon monoxide can quickly build up in these spaces and can linger for hours, even after this product has shut off.
- **ALWAYS** place this product downwind and point the engine exhaust away from occupied spaces.

If you start to feel sick, dizzy, or weak while using this product, shut it off and get to fresh air **RIGHT AWAY**. See a doctor. You may have carbon monoxide poisoning.

**⚠ WARNING** The engine exhaust from this product contains chemicals known to the State of California to cause cancer, birth defects, or other reproductive harm.

**⚠ WARNING** Certain components in this product and related accessories contain chemicals known to the State of California to cause cancer, birth defects or other reproductive harm. Wash hands after handling.

**⚠ WARNING** Starter cord kickback (rapid retraction) will pull hand and arm toward engine faster than you can let go which could cause broken bones, fractures, bruises, or sprains resulting in serious injury.

- When starting engine, pull cord slowly until resistance is felt and then pull rapidly to avoid kickback.
- **NEVER** start or stop engine with electrical devices plugged in and turned on.

**⚠ WARNING** Fuel and its vapors are extremely flammable and explosive which could cause burns, fire or explosion resulting in death or serious injury.

### WHEN ADDING OR DRAINING FUEL

- Turn generator engine **OFF** and let it cool at least 2 minutes before removing fuel cap. Loosen cap slowly to relieve pressure in tank.
- Fill or drain fuel tank outdoors.
- **DO NOT** overfill tank. Allow space for fuel expansion.
- If fuel spills, wait until it evaporates before starting engine.
- Keep fuel away from sparks, open flames, pilot lights, heat, and other ignition sources.
- Check fuel lines, tank, cap and fittings frequently for cracks or leaks. Replace if necessary.
- **DO NOT** light a cigarette or smoke.

### WHEN STARTING EQUIPMENT

- Ensure spark plug, muffler, fuel cap, and air cleaner are in place.
- **DO NOT** crank engine with spark plug removed.

### WHEN OPERATING EQUIPMENT

- **DO NOT** operate this product inside any building, carport, porch, mobile equipment, marine applications, or enclosure.
- **DO NOT** tip engine or equipment at angle which causes fuel to spill.
- **DO NOT** stop engine by moving choke control to "**Choke**" position (I\I).

### WHEN TRANSPORTING, MOVING OR REPAIRING EQUIPMENT

- Transport/move/repair with fuel tank **EMPTY** or with fuel shutoff valve **OFF**.
- **DO NOT** tip engine or equipment at angle which causes fuel to spill.
- Disconnect spark plug wire.

### WHEN STORING FUEL OR EQUIPMENT WITH FUEL IN TANK

- Store away from furnaces, stoves, water heaters, clothes dryers, or other appliances that have pilot light or other ignition source because they could ignite fuel vapors.

### ⚠ WARNING

- This generator does not meet U. S. Coast Guard Regulation 33CFR-183 and should not be used on marine applications.
- Failure to use the appropriate U. S. Coast Guard approved generator could result in death or serious injury.



 **WARNING** Generator voltage could cause electrical shock or burn resulting in death or serious injury.

- Use listed transfer equipment, suitable for the intended use, to prevent backfeed by isolating generator from electric utility workers.
- When using generator for backup power, notify utility company.
- Use a ground fault circuit interrupter (GFCI) in any damp or highly conductive area, such as metal decking or steel work.
- DO NOT touch bare wires or receptacles.
- DO NOT use generator with electrical cords which are worn, frayed, bare or otherwise damaged.
- DO NOT operate generator in the rain or wet weather.
- DO NOT handle generator or electrical cords while standing in water, while barefoot, or while hands or feet are wet.
- DO NOT allow unqualified persons or children to operate or service generator.

 **WARNING** Exhaust heat/gases could ignite combustibles, structures or damage fuel tank causing a fire, resulting in death or serious injury.

Contact with muffler area could cause burns resulting in serious injury.

- DO NOT touch hot parts and AVOID hot exhaust gases.
- Allow equipment to cool before touching.
- Keep at least 5 feet (1.5 m) of clearance on all sides of generator including overhead.
- It is a violation of California Public Resource Code, Section 4442, to use or operate the engine on any forest-covered, brush-covered, or grass-covered land unless the exhaust system is equipped with a spark arrester, as defined in Section 4442, maintained in effective working order. Other states or federal jurisdictions may have similar laws.

Contact the original equipment manufacturer, retailer, or dealer to obtain a spark arrester designed for the exhaust system installed on this engine.

- Replacement parts must be the same and installed in the same position as the original parts.

 **WARNING** Unintentional sparking could cause fire or electric shock resulting in death or serious injury.

**WHEN ADJUSTING OR MAKING REPAIRS TO YOUR GENERATOR**

- Disconnect the spark plug wire from the spark plug and place the wire where it cannot contact spark plug.

**WHEN TESTING FOR ENGINE SPARK**

- Use approved spark plug tester.
- DO NOT check for spark with spark plug removed.

 **WARNING** Starter and other rotating parts could entangle hands, hair, clothing, or accessories resulting in serious injury.

- NEVER operate generator without protective housing or covers.
- DO NOT wear loose clothing, jewelry or anything that could be caught in the starter or other rotating parts.
- Tie up long hair and remove jewelry.

 **CAUTION** Excessively high operating speeds could result in minor injury.

Excessively low operating speeds impose a heavy load.

- DO NOT tamper with governor spring, links or other parts to increase engine speed. Generator supplies correct rated frequency and voltage when running at governed speed.
- DO NOT modify generator in any way.

**NOTICE** Exceeding generators wattage/amperage capacity could damage generator and/or electrical devices connected to it.

- DO NOT exceed the generator's wattage/amperage capacity. See *Don't Overload Generator* in the *Operation* section.
- Start generator and let engine stabilize before connecting electrical loads.
- Connect electrical loads in OFF position, then turn ON for operation.
- Turn electrical loads OFF and disconnect from generator before stopping generator.

**NOTICE** Improper treatment of generator could damage it and shorten its life.

- Use generator only for intended uses.
- If you have questions about intended use, ask dealer or contact local service center.
- Operate generator only on level surfaces.
- DO NOT expose generator to excessive moisture, dust, dirt, or corrosive vapors.
- DO NOT insert any objects through cooling slots.
- If connected devices overheat, turn them off and disconnect them from generator.
- Shut off generator if:
  - electrical output is lost;
  - equipment sparks, smokes, or emits flames;
  - unit vibrates excessively.

## Assembly

Your generator requires some assembly and is ready for use after it has been properly serviced with the recommended fuel and oil level is verified.

If you have any problems with the assembly of your generator, please call the generator helpline at **(800) 743-4115**. If calling for assistance, please have the model, revision, and serial number from the identification label available.

### Unpack Generator

1. Set the carton on a rigid, flat surface.
2. Remove everything from carton except generator.
3. Open carton completely by cutting each corner from top to bottom.
4. Leave generator on carton to install wheel kit.

### The generator is supplied with:

- Operator's manual
- Battery float charger
- Wheel kit
- Keys (2)

### Install Wheel Kit

**NOTICE** Wheel kit is not intended for over-the-road use.

You will need the following tools to install these components:

- 13 mm and 19 mm wrench
- Socket wrench with 10 mm and 16 mm sockets

### Install the wheel kit as follows:

1. Tip generator so that engine side is down.
2. Slide axle stud (A) through mounting bracket with threaded end facing out.

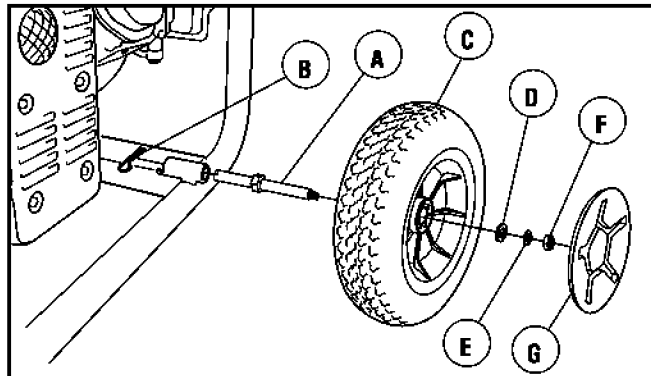

3. Insert retaining pin (B) through hole on axle stud.
4. Slide a wheel (C) over axle stud.

**NOTICE** Be sure to install wheel with raised hub inboard.

5. Attach wheel to axle stud with a washer (D), lock washer (E) and nut (F). Tighten with a 16 mm socket wrench and 19 mm wrench.
6. Place hub cap (G) into center of wheel and push until it snaps into place.

7. Repeat steps 2 through 6 to secure second wheel.
8. Line up holes in support leg (H) with holes in generator frame.

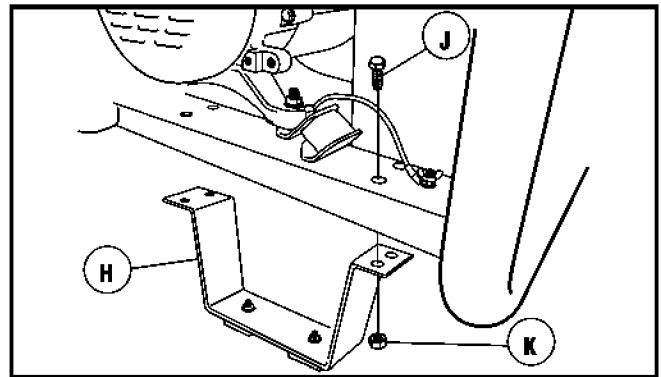

9. Attach support leg using 4 capscrews (J) and 4 hex nuts (K). Tighten with a 10 mm socket wrench and 13 mm wrench.
10. Return generator to normal operating position (resting on wheels).

### Attach Negative Battery Cable

Your unit is equipped with electric start capability but can be started manually. If you choose not to use the electric start feature, you do not need to connect the negative battery cable.

The sealed battery on the generator pre-installed except for the negative (black) battery cable.

**▲ WARNING** Battery posts, terminals and related accessories contain lead and lead compounds - chemicals known to the State of California to cause cancer and reproductive harm. Wash hands after handling.

### To install:

1. Cut off tie wrap securing loose end of negative (black) cable.
2. Using 8 mm or 5/16" wrenches, remove nut (H), lock washer (J) and flat washer (K) on negative battery terminal (-).

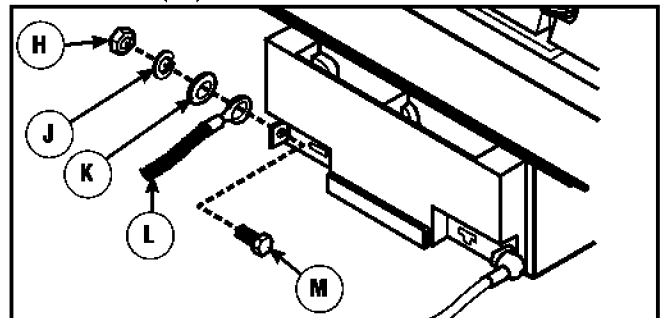

3. Slide negative battery cable (L) over screw (M) on negative terminal.
4. Reattach washer and nut and tighten.
5. Verify that connections to battery and generator are tight and secure.

**NOTICE** If your battery is discharged, charge prior to use following the instructions in the section *Battery Charger*.

## Verify Engine Oil Level

The generator engine is shipped from the factory filled with oil (API SJ or higher 10W-30). This allows for generator operation in the widest range of temperature and climate conditions. Before starting the engine, check oil level and ensure that engine is serviced as described in *Maintenance*.

**NOTICE** Any attempt to crank or start the engine before it has been properly filled with the recommended oil could result in equipment failure.

- Refer to *Maintenance* for oil fill information.
- Damage to equipment resulting from failure to follow this instruction will void warranty.

**NOTICE** See *Oil* in the *Maintenance* section to review oil recommendations. Verify provided oil in engine is the correct viscosity for current ambient temperature.

## Add Fuel

**Fuel must meet these requirements:**

- Clean, fresh, unleaded gasoline.
- A minimum of 87 octane/87 AKI (91 RON). For high altitude use, see *High Altitude*.
- Gasoline with up to 10% ethanol (gasohol) is acceptable.

**NOTICE** Use of unapproved fuels could damage generator and voids warranty.

- DO NOT use unapproved gasoline such as E15 and E85.
- DO NOT mix oil in gasoline or modify engine to run on alternate fuels.

To protect the fuel system from gum formation, mix in a fuel stabilizer when adding fuel. See *Storage*. All fuel is not the same. If you experience starting or performance problems after using fuel, switch to a different fuel provider or change brands. This engine is certified to operate on gasoline. The emission control system for this engine is EM (Engine Modifications).

**⚠ WARNING** Fuel and its vapors are extremely flammable and explosive which could cause burns, fire or explosion resulting in death or serious injury.

### WHEN ADDING FUEL

- Turn generator engine OFF and let it cool at least 2 minutes before removing fuel cap. Loosen cap slowly to relieve pressure in tank.
- Fill fuel tank outdoors.
- DO NOT overfill tank. Allow space for fuel expansion.
- If fuel spills, wait until it evaporates before starting engine.
- Keep fuel away from sparks, open flames, pilot lights, heat, and other ignition sources.
- Check fuel lines, tank, cap and fittings frequently for cracks or leaks. Replace if necessary.
- DO NOT light a cigarette or smoke.

1. Clean area around fuel fill cap, remove cap.
2. Slowly add unleaded gasoline (A) to fuel tank (B). Be careful not to fill above the baffle (C). This allows adequate space for fuel expansion as shown.

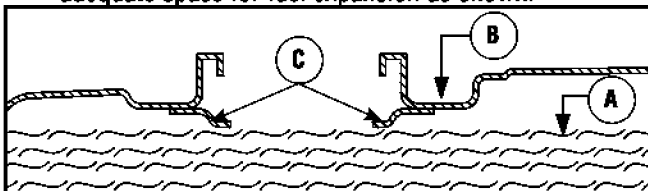

3. Install fuel cap and let any spilled fuel evaporate before starting engine.

## High Altitude

At altitudes over 5,000 feet (1524 meters), a minimum 85 octane / 85 AKI (89 RON) gasoline is acceptable. To remain emissions compliant, high altitude adjustment is required. Operation without this adjustment will cause decreased performance, increased fuel consumption, and increased emissions. See an authorized dealer for high altitude adjustment information. Operation of the engine at altitudes below 2,500 feet (762 meters) with the high altitude kit is not recommended.

## System Ground

The generator has a system ground that connects the generator frame components to the ground terminals on the AC output receptacles. The system ground is connected to the AC neutral wire (the neutral is bonded to the generator frame).

## Special Requirements

There may be Federal or State Occupational Safety and Health Administration (OSHA) regulations, local codes, or ordinances that apply to the intended use of the generator. Please consult a qualified electrician, electrical inspector, or the local agency having jurisdiction:

- In some areas, generators are required to be registered with local utility companies.
- If the generator is used at a construction site, there may be additional regulations which must be observed.

## Connecting to a Building's Electrical System

Connections for standby power to a building's electrical system must use a listed transfer switch installed by a current licensed electrician. The connection must isolate the generator power from the utility power and must comply with all applicable laws and electrical codes.

**⚠ WARNING** Generator voltage could cause electrical shock or burn resulting in death or serious injury.

- Use listed transfer equipment, suitable for the intended use, to prevent backfeed by isolating generator from electric utility workers.
- When using generator for backup power, notify utility company.
- Use a ground fault circuit interrupter (GFCI) in any damp or highly conductive area, such as metal decking or steel work.
- DO NOT touch bare wires or receptacles.
- DO NOT use generator with electrical cords which are worn, frayed, bare or otherwise damaged.
- DO NOT operate generator in the rain or wet weather.
- DO NOT handle generator or electrical cords while standing in water, while barefoot, or while hands or feet are wet.
- DO NOT allow unqualified persons or children to operate or service generator.

## Portable Generator Location

Before starting the portable generator there are two equally important safety concerns regarding carbon monoxide (CO) poisoning and fire that must be addressed.

**NOTICE** Satisfying the RISK OF CARBON MONOXIDE POISONING location requirements may not satisfy the fire location requirements. Satisfying the RISK OF FIRE location requirements may not satisfy the CARBON MONOXIDE POISONING location requirements.

### Operation Location of Portable Generator to REDUCE THE RISK OF CARBON MONOXIDE POISONING

All fossil fuel burning equipment, such as a portable generator, contains carbon monoxide (CO) gas in the engine exhaust, a poisonous gas that could kill you in minutes. You CANNOT smell it, see it, or taste it. Even if you do not smell exhaust fumes, you could still be exposed to carbon monoxide gas. The following must be completed prior to starting the portable generator engine:

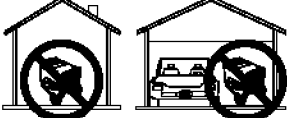
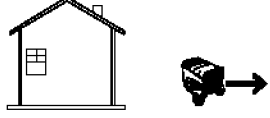
<b>⚠ DANGER</b>	
<b>Using a generator indoors CAN KILL YOU IN MINUTES.</b>	
<b>Generator exhaust contains carbon monoxide. This is a poison you cannot see or smell.</b>	
	
<b>NEVER use inside a home or garage, EVEN IF doors and windows are open.</b>	<b>Only use OUTSIDE and far away from windows, doors, and vents.</b>

- By law it is required in many states to have a Carbon Monoxide (CO) alarm (A) in operating condition in your home. Install/maintain battery-operated carbon monoxide alarms or plug-in carbon monoxide alarms with battery back-up according to the manufacturer's instructions. A CO alarm is an electronic device that detects hazardous levels of CO. When there is a buildup of CO, the alarm will alert the occupants by flashing visual indicator light and alarm. Smoke alarms cannot detect CO gas.

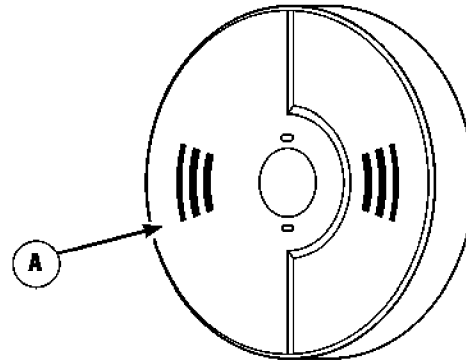

- Operate this product ONLY outside far away from windows, doors and vents to reduce the risk of carbon monoxide gas from accumulating and potentially being drawn towards occupied spaces.
- DO NOT run this product inside homes, garages, basements, crawlspaces, sheds, or other partially-enclosed spaces even if using fans or opening doors and windows for ventilation. Carbon monoxide can quickly build up in these spaces and can linger for hours, even after this product has shut off.
- Your neighbor(s) home may be exposed to the engine exhaust from your portable generator and must be considered when deciding on a location for the safe operation of your portable generator.
- ALWAYS place this product downwind and point the engine exhaust away from occupied spaces.

If you start to feel sick, dizzy, or weak while using this product, shut it off and get to fresh air RIGHT AWAY. See a doctor. You may have carbon monoxide poisoning.

## EXAMPLE OF LOCATION TO REDUCE THE RISK OF CARBON MONOXIDE POISONING

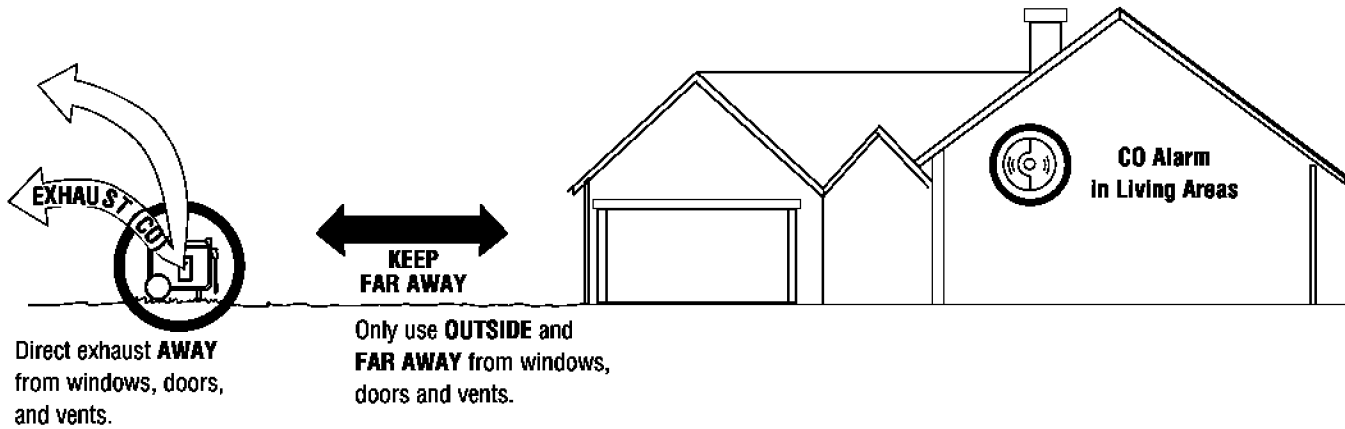

## DO NOT OPERATE IN ANY OF THE FOLLOWING LOCATIONS

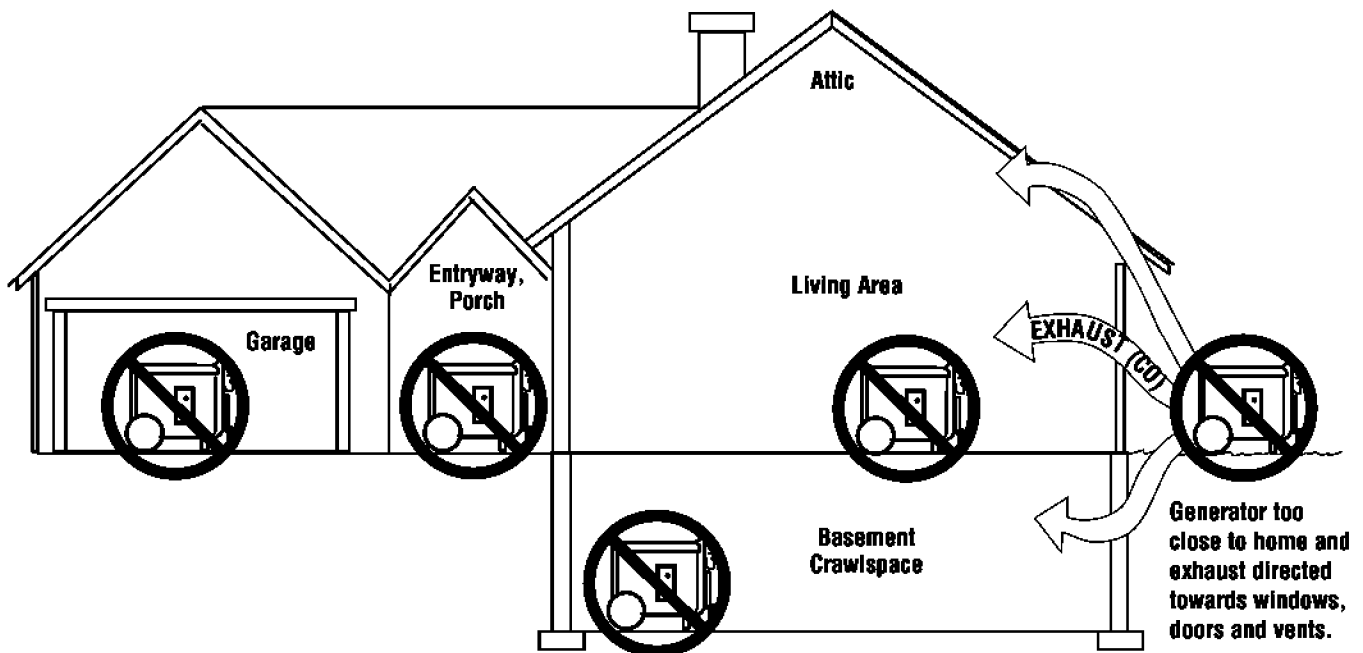

**Operation Location of Portable Generator to REDUCE THE RISK OF FIRE**

**⚠ WARNING** Exhaust heat/gases could ignite combustibles, structures or damage fuel tank causing a fire, resulting in death or serious injury.

- Portable generator must be at least 5 feet (1.5 m) from any structure, overhang, trees, windows, doors, any wall opening, shrubs, or vegetation over 12 inches (30.5 cm) in height.
- DO NOT place portable generator under a deck or other type of structure that may confine airflow.
- Smoke alarm(s) MUST be installed and maintained indoors according to the manufacturer's instructions/recommendations. Carbon monoxide alarms cannot detect smoke.
- DO NOT place portable generator in manner other than shown.

**EXAMPLE OF LOCATION TO REDUCE THE RISK OF FIRE**

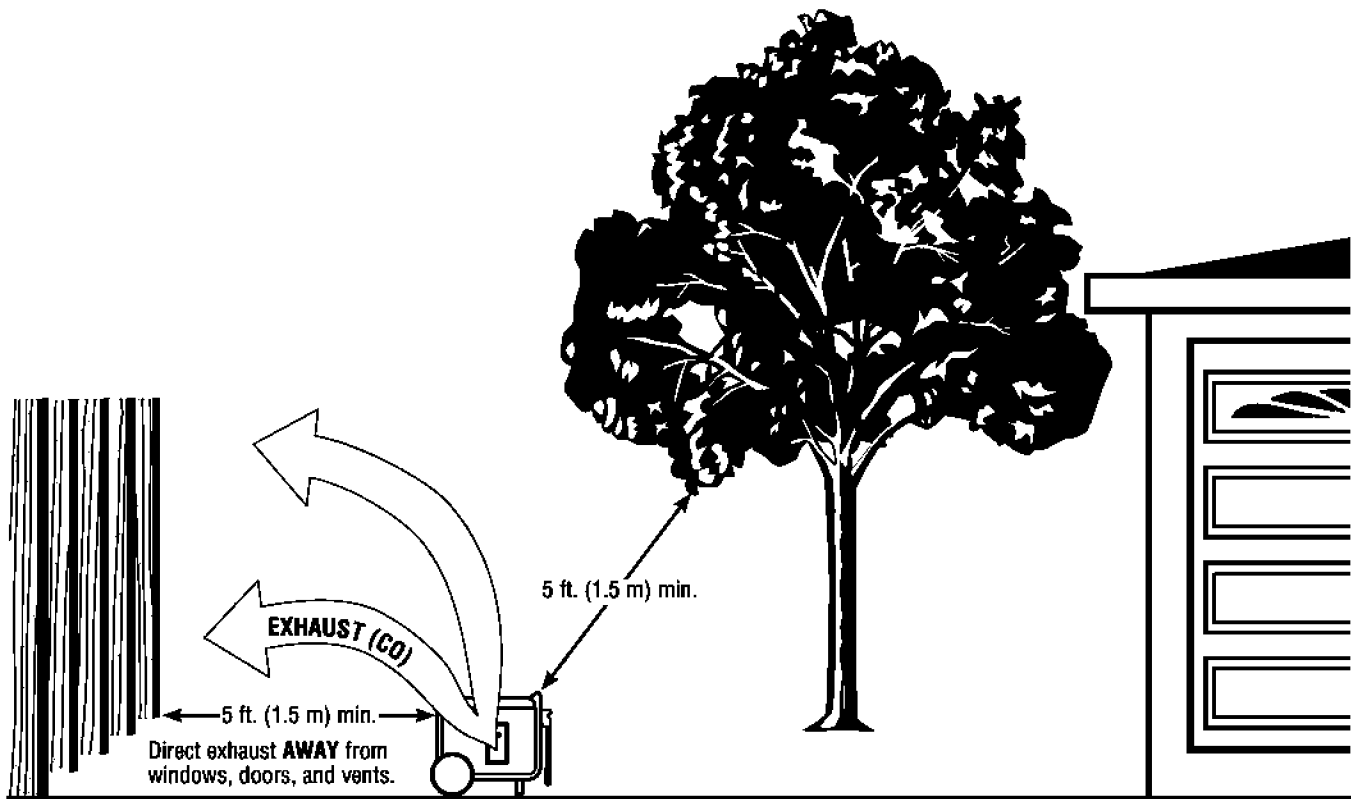

## Features and Controls



**Read this Operator's Manual and safety rules before operating your generator.**

Compare the illustrations with your generator, to familiarize yourself with the locations of various controls and adjustments. Save this manual for future reference.

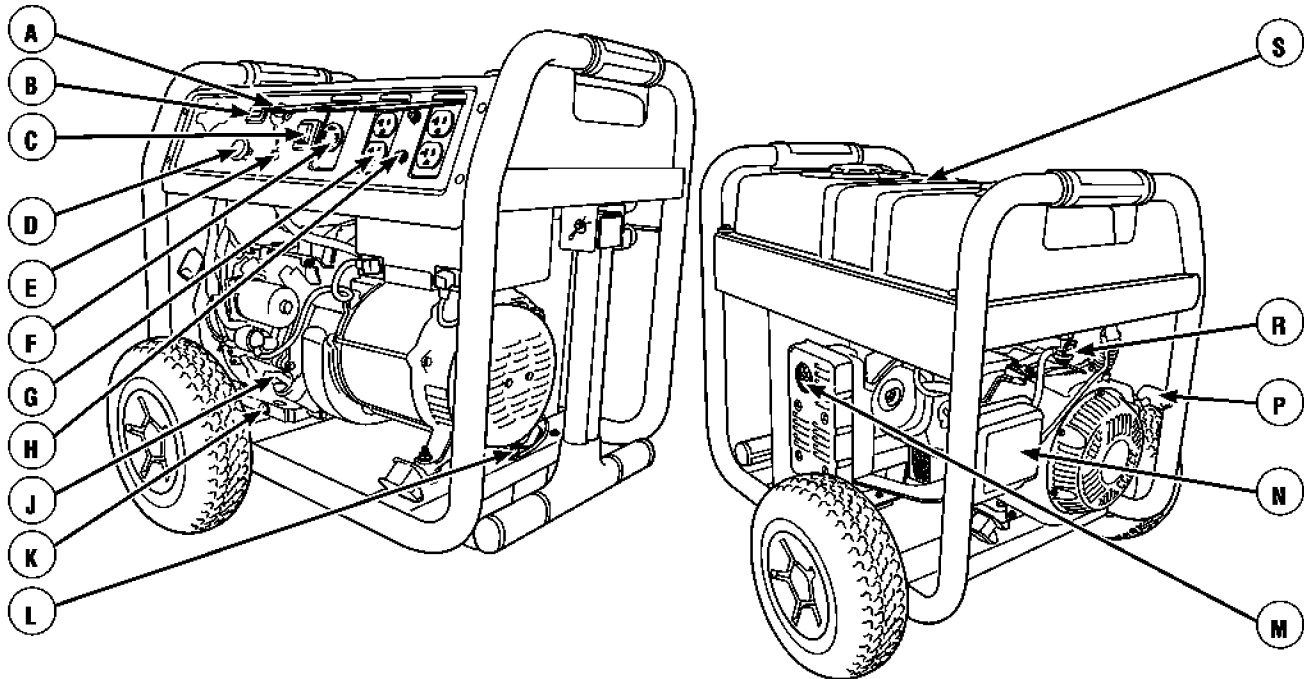

- A - Start Switch** — Turn key to start (🔑) position to start the engine. Turn key to OFF (0) position to switch off engine.
- B - Hour Meter** — Displays and records how many hours your generator has run (up to 9,999.9).
- C - Rocker Switch Circuit Breaker** — The 120/240 Volt AC, 30A locking receptacle is provided with a 2 pole rocker switch circuit breaker to protect the generator against electrical overload.
- D - Choke Control** — Used when starting a cold engine.
- E - Battery Float Charger Jack** — Use battery float charger jack to keep the starting battery charged and ready for use.
- F - 120/240 Volt AC, 30 Amp Locking Receptacle** — May be used to supply electrical power for the operation of 120 and/or 240 Volt AC, 30 Amp, single phase, 60 Hz electrical, lighting, appliance, tool and motor loads.
- G - 120 Volt AC, 20 Amp, Duplex Receptacle** — May be used to supply electrical power for the operation of 120 Volt AC, 20 Amp, single phase, 60 Hz electrical, lighting, appliance, tool and motor loads.
- H - Circuit Breakers (AC)** — The 120 Volt AC, 20A duplex receptacles are provided with “push to reset” circuit breakers to protect the generator against electrical overload.

- J - Oil Fill Cap/Dipstick** — Check and add engine oil here.
- K - Oil Drain Plug** — Drain engine oil here.
- L - Grounding Fastener** — Consult your local agency having jurisdiction for grounding requirements in your area.
- M - Spark Arrester Muffler** — Exhaust muffler lowers engine noise and is equipped with a spark arrester screen.
- N - Air Cleaner** — Protects engine by filtering dust and debris out of intake air.
- P - Recoil Starter** — Used to start the engine manually.
- R - Fuel Valve** — Used to turn fuel supply on and off to engine.
- S - Fuel Tank** — Capacity of seven (7) U.S. gallons (26.5 l).

### Items Not Shown:

**Engine Identification** — Provides model, type and code of engine. Please have these readily available if calling for assistance.

**Identification Label** — Provides model and serial number of generator. Please have these readily available if calling for assistance.

## Cord Sets and Receptacles

Use only high quality, well-insulated, grounded extension cords with the generator's receptacles. Inspect extension cords before each use.

Check the ratings of all extension cords before you use them. Check the operator's manuals of devices for the manufacturer's recommendations.

A double pole rocker switch main circuit breaker is provided to protect the locking receptacle. If this circuit breaker is tripped, all receptacles are disconnected.

**WARNING** Damaged or overloaded electrical cords could overheat, arc, and burn resulting in death or serious injury.

- ONLY use cords rated for your loads.
- Follow all safeties on electrical cords.
- Inspect cord sets before each use.

## 120/240 Volt AC, 30 Amp, Locking Receptacle

Use a NEMA L14-30 plug with this receptacle. Connect a 4-wire cord set rated for 250 Volt AC loads at 30 Amps (or greater). You can use the same 4-wire cord if you plan to run a 120 Volt load.

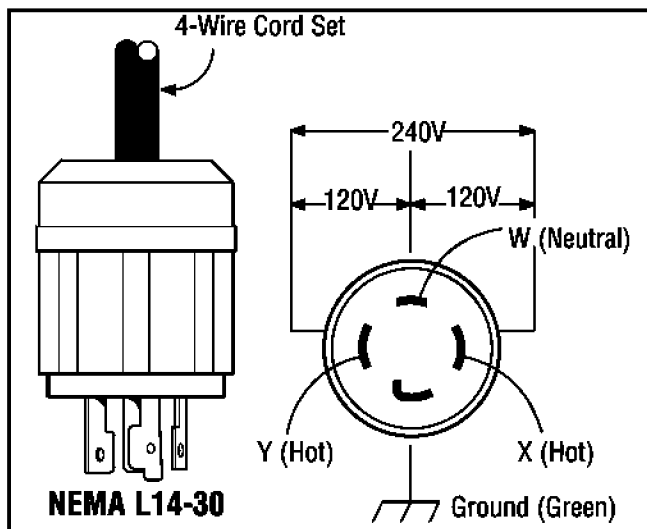

This receptacle powers 120/240 Volt AC, 60 Hz, single phase loads requiring up to 7200 watts of power (7.2 kW) at 30 Amps for 240 Volts or two independent 120 Volt loads at 30 Amps each. The outlet is protected by a two pole rocker switch circuit breaker.

**NOTICE** Receptacles may be marked with rating value greater than generator output capacity.

- NEVER attempt to power a device requiring more amperage than generator or receptacle can supply.
- DO NOT overload the generator. See *Don't Overload Generator*.

## 120 Volt AC, 20 Amp, Duplex Receptacles

The generator has two 120 Volt, 20 Amp duplex receptacles. The receptacles are protected against overload by push-to-reset circuit breakers.

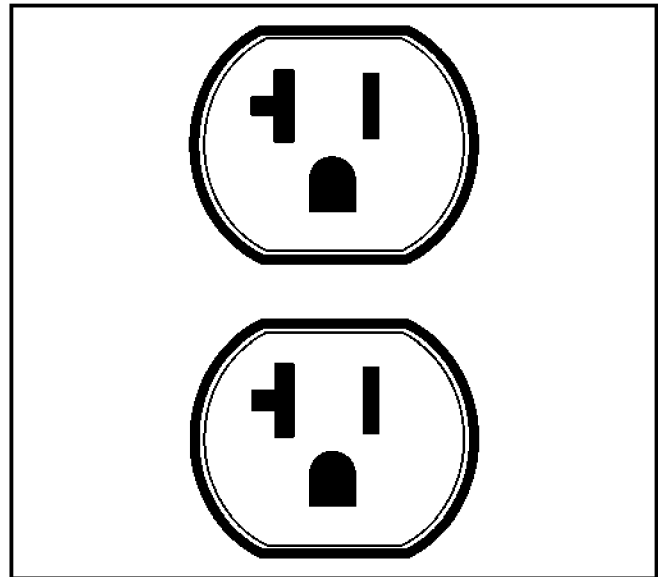

Use each receptacle to operate 120 Volt AC, single-phase, 60 Hz electrical loads requiring up to 2,400 watts (2.4 kW) at 20 Amps of current. Use cord sets that are rated for 125 Volt AC loads at 20 Amps (or greater). Inspect cord sets before each use.

## Battery Charger

Use battery float charger jack to keep the starting battery charged and ready for use. Battery charging should be done in a dry location, such as inside a garage.

1. Plug charger into unit's "Battery Float Charger" jack, which is located next to the start switch. Plug battery charger into a 120 Volt AC wall receptacle.

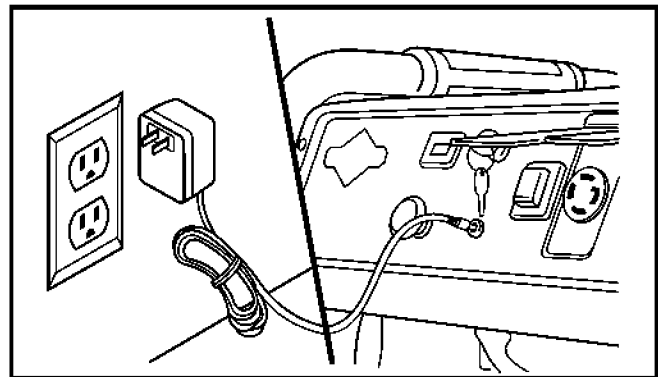

2. Unplug charger from unit and wall outlet when generator is being started and while it is in operation.
3. Keep this charger plugged in when generator is not in use to prolong battery life. The charger has a built in float equalizer and will not overcharge the battery, even when plugged in for an extended period of time.

**NOTICE** See *Battery Maintenance* for additional information.



# Operation

## Starting the Engine

Disconnect all electrical loads from the generator. Use the following start instructions:

1. Make sure unit is on a level surface.

**NOTICE** Failure to start and operate the unit on a level surface will cause the unit not to start or shut down during operation.

2. Turn the fuel valve (A) to the ON (I) position.

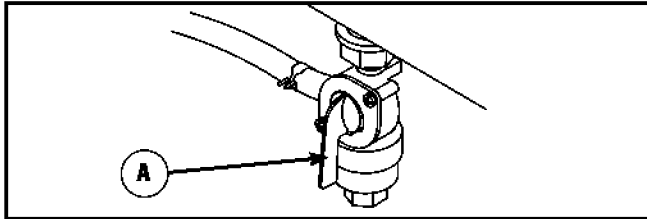

3. Pull choke control out to close choke (I↖).

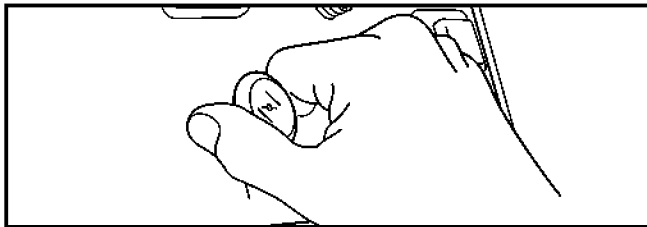

- 4A. For electric starting, turn and hold key in start switch to start (I↖) position until generator starts. To prolong the life of starter components, DO NOT hold key in start (I↖) position for more than 5 seconds, and pause for at least 30 seconds between starting attempts.

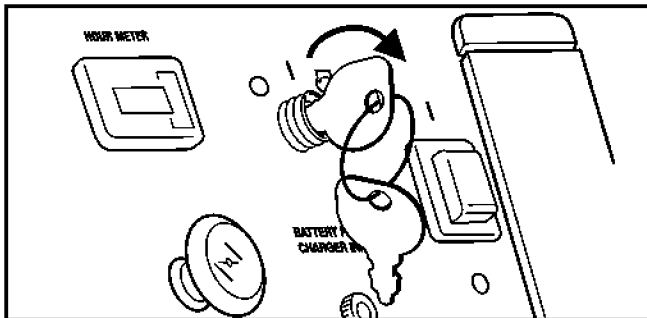

- If engine starts, proceed to step 6.
- If engine fails to start, proceed to step 5.

**NOTICE** If battery is discharged, use manual starting instructions.

- 4B. For manual starting, turn key in start switch to run (I) position, grasp recoil handle and pull slowly until slight resistance is felt. Then pull rapidly one time only to start engine.

- If engine starts, proceed to step 6.
- If engine fails to start, proceed to step 5.

**WARNING** Starter cord kickback (rapid retraction) will pull hand and arm toward engine faster than you can let go which could cause broken bones, fractures, bruises, or sprains resulting in serious injury.

- When starting engine, pull cord slowly until resistance is felt and then pull rapidly to avoid kickback.
- NEVER start or stop engine with electrical devices plugged in and turned on.

5. Push in the choke handle half way, turn key in start switch to run (I) position and pull recoil handle twice or turn and hold key in start switch to start (I↖) position as described in step 4A.

- If engine fails to start, repeat steps 3 thru 4.

6. Open the choke gradually as the engine warms up by pushing in on the choke handle.

**NOTICE** If engine floods, push choke handle all the way in and crank until engine starts.

**NOTICE** If engine starts after 3 pulls but fails to run, or if unit shuts down during operation, make sure unit is on a level surface and check for proper oil level in crankcase. This unit may be equipped with a low oil protection device. If so, oil must be at proper level for engine to start.

**WARNING** Exhaust heat/gases could ignite combustibles, structures or damage fuel tank causing a fire, resulting in death or serious injury.

Contact with muffler area could cause burns resulting in serious injury.

- DO NOT touch hot parts and AVOID hot exhaust gases.
- Allow equipment to cool before touching.
- Keep at least 5 feet (1.5 m) of clearance on all sides of generator including overhead.
- It is a violation of California Public Resource Code, Section 4442, to use or operate the engine on any forest-covered, brush-covered, or grass-covered land unless the exhaust system is equipped with a spark arrester, as defined in Section 4442, maintained in effective working order. Other states or federal jurisdictions may have similar laws.

Contact the original equipment manufacturer, retailer, or dealer to obtain a spark arrester designed for the exhaust system installed on this engine.

- Replacement parts must be the same and installed in the same position as the original parts.

## Connecting Electrical Loads

1. Let engine stabilize and warm up for a few minutes after starting.
2. Ensure circuit breaker on control panel is in ON (I) position.
3. Plug in and turn on the desired 120 and/or 240 Volt AC, single phase, 60 Hz electrical loads.

**NOTICE** When plugging into the 120 Volt receptacles, plug items to be powered in sequence as shown below.

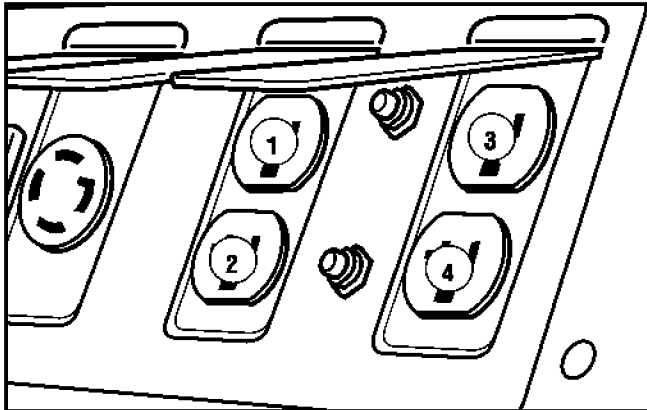

### NOTICE

- DO NOT connect 240 Volt loads to the 120 Volt duplex receptacles.
- DO NOT connect 3-phase loads to the generator.
- DO NOT connect 50 Hz loads to the generator.
- DO NOT OVERLOAD THE GENERATOR. See *Don't Overload Generator*.

**NOTICE** Exceeding generators wattage/amperage capacity could damage generator and/or electrical devices connected to it.

- DO NOT exceed the generator's wattage/amperage capacity. See *Don't Overload Generator* in the *Operation* section.
- Start generator and let engine stabilize before connecting electrical loads.
- Connect electrical loads in OFF position, then turn ON for operation.
- Turn electrical loads OFF and disconnect from generator before stopping generator.

## Stopping the Engine

1. Turn OFF and unplug **all** electrical loads from generator panel receptacles. NEVER start or stop engine with electrical devices plugged in and turned ON.
2. Let engine run at no-load for several minutes to stabilize internal temperatures of engine and generator.
3. Turn key in start switch to OFF (0) position.

**WARNING** Fuel and its vapors are extremely flammable and explosive which could cause burns, fire or explosion resulting in death or serious injury.

- DO NOT stop engine by moving choke lever to CHOKE position (I\).

4. Move fuel valve to OFF (0) position.

## Low Oil Shutdown

If the engine oil drops below a preset level, an oil switch will stop the engine. Check oil level with dipstick.

**If oil level is between ADD and FULL mark on dipstick:**

1. DO NOT try to restart the engine.
2. Contact an Authorized Briggs & Stratton Service Dealer.
3. DO NOT operate engine until oil level is corrected.

**If oil level is below ADD mark on dipstick:**

1. Add oil to bring level to FULL mark.
2. Restart engine and if the engine stops again a low oil condition may still exist. DO NOT try to restart the engine.
3. Contact an Authorized Briggs & Stratton Service Dealer.
4. DO NOT operate engine until oil level is corrected.

## Cold Weather Operation

Under certain weather conditions (temperatures below 40°F [4°C] combined with high humidity), your generator may experience icing of the carburetor and/or the crankcase breather system. To reduce this problem, you need to perform the following:

1. Make sure generator has clean, fresh fuel.
2. Turn the fuel valve to the ON (I) position.
3. Use SAE 5W-30 oil.
4. Check oil level daily or after every eight (8) hours of operation.
5. Maintain generator following *Maintenance Schedule* in *Maintenance* section.
6. Shelter unit from elements.

### Creating a Temporary Cold Weather Shelter

1. For temporary shelter, the original shipping carton can be used.
2. Cut off top carton flaps and one long side of carton to expose muffler side of unit. If required, tape up other sides of carton to fit over generator as shown.

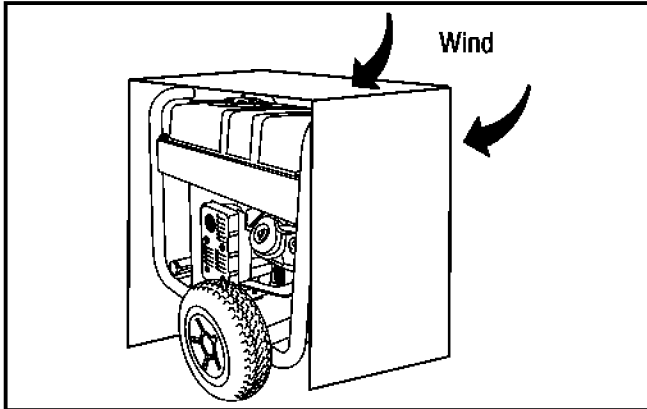

**NOTICE** If required, remove wheel kit to fit carton over generator as shown.

3. Cut appropriate slots to access receptacles of unit.
4. Face exposed end away from wind and elements.
5. Locate generator as described in the section *Generator Location*. Keep exhaust gas from entering a confined area through windows, doors, ventilation intakes or other openings.

**WARNING** POISONOUS GAS HAZARD. Engine exhaust contains carbon monoxide, a poisonous gas that could kill you in minutes. You CANNOT smell it, see it, or taste it. Even if you do not smell exhaust fumes, you could still be exposed to carbon monoxide gas.

- Operate this product ONLY outside far away from windows, doors and vents to reduce the risk of carbon monoxide gas from accumulating and potentially being drawn towards occupied spaces.
- Install battery-operated carbon monoxide alarms or plug-in carbon monoxide alarms with battery back-up according to the manufacturer's instructions. Smoke alarms cannot detect carbon monoxide gas.
- DO NOT run this product inside homes, garages, basements, crawlspaces, sheds, or other partially-enclosed spaces even if using fans or opening doors and windows for ventilation. Carbon monoxide can quickly build up in these spaces and can linger for hours, even after this product has shut off.
- ALWAYS place this product downwind and point the engine exhaust away from occupied spaces.

If you start to feel sick, dizzy, or weak while using this product, shut it off and get to fresh air RIGHT AWAY. See a doctor. You may have carbon monoxide poisoning.

6. Start generator as described in the section *Starting the Engine*, then place carton over generator. Keep at least 5 ft. (1.5 m) clearance on all sides of generator including overhead with shelter in place.

**WARNING** Exhaust heat/gases could ignite combustibles, structures or damage fuel tank causing a fire, resulting in death or serious injury.

Contact with muffler area could cause burns resulting in serious injury.

- DO NOT touch hot parts and AVOID hot exhaust gases.
- Allow equipment to cool before touching.
- Keep at least 5 feet (1.5 m) of clearance on all sides of generator including overhead.
- Remove shelter when temperatures are above 40°F [4°C].

7. Remove shelter when temperatures are above 40°F [4°C].

8. Turn engine OFF and let cool two (2) minutes before refueling. Let any spilled fuel evaporate before starting engine.

### Building a Cold Weather Shelter

1. Using non combustible material with a fire rating of at least one hour, build a shelter that will enclose three sides and the top of the generator. Make sure muffler side of generator is exposed.

**NOTICE** Contact your local building material supplier for non combustible materials with a fire rating of at least one hour.

**NOTICE** Be sure shelter can easily be repositioned for change in wind direction.

2. DO NOT enclose generator any more than shown. Shelter should hold enough heat created by the generator to prevent icing problem.

**NOTICE** If a wheel kit is installed on the generator, enlarge shelter accordingly.

3. Follow steps 3 through 8 as described previously in *Creating a Temporary Cold Weather Shelter*.

## Don't Overload Generator

### Capacity

You must make sure your generator can supply enough rated (running) and surge (starting) watts for the items you will power at the same time. Follow these simple steps:

1. Select the items you will power at the same time.
2. Total the rated (running) watts of these items. This is the amount of power your generator must produce to keep your items running. See Wattage Reference Guide.
3. Estimate how many surge (starting) watts you will need. Surge wattage is the short burst of power needed to start electric motor-driven tools or appliances such as a circular saw or refrigerator. Because not all motors start at the same time, total surge watts can be estimated by adding only the item(s) with the highest additional surge watts to the total rated watts from step 2.

### Example:

Tool or Appliance	Rated (Running) Watts	Additional Surge (Starting) Watts
Window Air Conditioner	1200	1800
Refrigerator	800	1600
Deep Freezer	500	500
Television	500	—
Light (75 Watts)	75	—
	3075 Total Running Watts	1800 Highest Additional Surge Watts

Total Rated (Running) Watts = 3075  
 Highest Additional Surge (Starting) Watts = 1800  
 Total Generator Output Required = 4875

### Power Management

To prolong the life of your generator and attached devices, it is important to take care when adding electrical loads to your generator. There should be nothing connected to the generator outlets before starting its engine. The correct and safe way to manage generator power is to sequentially add loads as follows:

1. With nothing connected to the generator, start the engine as described in this manual.
2. Plug in and turn on the first load, preferably the largest load you have.
3. Permit the generator output to stabilize (engine runs smoothly and attached device operates properly).
4. Plug in and turn on the next load.
5. Again, permit the generator to stabilize.
6. Repeat steps 4 and 5 for each additional load.

NEVER add more loads than the generator capacity. Take special care to consider surge loads in generator capacity, as described above.

Tool or Appliance	Rated* (Running) Watts	Additional Surge (Starting) Watts
<b>Essentials</b>		
Light Bulb - 75 watt	75	-
Deep Freezer	500	500
Sump Pump	800	1200
Refrigerator/Freezer - 18 Cu. Ft.	800	1600
Water Well Pump - 1/3 HP	1000	2000
<b>Heating/Cooling</b>		
Window AC - 10,000 BTU	1200	1800
Window Fan	300	600
Furnace Fan Blower - 1/2 HP	800	1300
<b>Kitchen</b>		
Microwave Oven - 1000 Watt	1000	-
Coffee Maker	1500	-
Electric Stove - Single Element	1500	-
Hot Plate	2500	-
<b>Family Room</b>		
DVD/CD Player	100	-
VCR	100	-
Stereo Receiver	450	-
Color Television - 27"	500	-
Personal Computer w/17" monitor	800	-
<b>Other</b>		
Security System	180	-
AM/FM Clock Radio	300	-
Garage Door Opener - 1/2 HP	480	520
Electric Water Heater - 40 Gallon	4000	-
<b>DIY</b>		
Quartz Halogen Work Light	1000	-
Airless Sprayer - 1/3 HP	600	1200
Reciprocating Saw	960	960
Electric Drill - 1/2 HP	1000	1000
Circular Saw - 7 1/4"	1500	1500
Miter Saw - 10"	1800	1800
Table Planer - 6"	1800	1800
Table Saw/Radial Arm Saw - 10"	2000	2000
Air Compressor - 1-1/2 HP	2500	2500

\* Wattages listed are approximate only. Check tool or appliance for actual wattage.

# Maintenance

## Maintenance Schedule

Follow the hourly or calendar intervals, whichever occurs first. More frequent service is required when operating in adverse conditions noted below.

• Change engine oil
• Clean debris
• Check engine oil level
• Clean engine air filter <sup>1</sup>
• Change engine oil <sup>1</sup>
• Replace engine air filter <sup>1</sup>
• Service fuel valve
• Service spark plug
• Inspect muffler and spark arrester
• Clean cooling system <sup>1</sup>

<sup>1</sup> Service more often under dirty or dusty conditions.

## General Recommendations

Regular maintenance will improve the performance and extend the life of the generator. See any authorized dealer for service.

The generator's warranty does not cover items that have been subjected to operator abuse or negligence. To receive full value from the warranty, the operator must maintain the generator as instructed in this manual.

Some adjustments will need to be made periodically to properly maintain your generator.

All service and adjustments should be made at least once each season. A new spark plug and clean air filter assure proper fuel-air mixture and help your engine run better and last longer. Follow the requirements in the *Maintenance Schedule* chart above.

## Emissions Control

**Maintenance, replacement, or repair of the emissions control devices and systems may be performed by any non-road engine repair establishment or individual.**

However, to obtain "no charge" emissions control service, the work must be performed by a factory authorized dealer. See the *Emissions Warranty*.

## Generator Maintenance

Generator maintenance consists of keeping the unit clean and dry. Operate and store the unit in a clean dry environment where it will not be exposed to excessive dust, dirt, moisture, or any corrosive vapors. Cooling air slots in the generator must not become clogged with snow, leaves, or any other foreign material.

**NOTICE** DO NOT use water or other liquids to clean generator. Liquids can enter engine fuel system, causing poor performance and/or failure to occur. In addition, if liquid enters generator through cooling air slots, some of the liquid will be retained in voids and cracks of the rotor and stator winding insulation. Liquid and dirt buildup on the generator internal windings will eventually decrease the insulation resistance of these windings.

## Cleaning

Daily or before use, look around and underneath the generator for signs of oil or fuel leaks. Clean accumulated debris from inside and outside the generator. Keep the linkage, spring and other engine controls clean. Keep the area around and behind the muffler free from any combustible debris. Inspect cooling air slots and openings on generator. These openings must be kept clean and unobstructed.

Engine parts should be kept clean to reduce the risk of overheating and ignition of accumulated debris:

- Use a damp cloth to wipe exterior surfaces clean.

**NOTICE** Improper treatment of generator could damage it and shorten its life.

- DO NOT expose generator to excessive moisture, dust, dirt, or corrosive vapors.
- DO NOT insert any objects through cooling slots.

- Use a soft bristle brush to loosen caked on dirt or oil.
- Use a vacuum cleaner to pick up loose dirt and debris.

## Battery Maintenance

Other than float charging, described elsewhere, no maintenance is required for the starting battery. Keep the battery and terminals clean and dry.

**NOTICE** Battery charging should be performed in a dry location, such as inside a garage.

**⚠ WARNING** Battery posts, terminals and related accessories contain lead and lead compounds - chemicals known to the State of California to cause cancer and reproductive harm. Wash hands after handling.

## Fuel Valve Maintenance

The fuel valve is equipped with a fuel sediment cup, screen, and o-ring that need to be cleaned.

1. Move fuel valve to OFF (O) position.
2. Remove sediment cup (A) from fuel valve. Remove o-ring (B) and screen (C) from fuel valve.

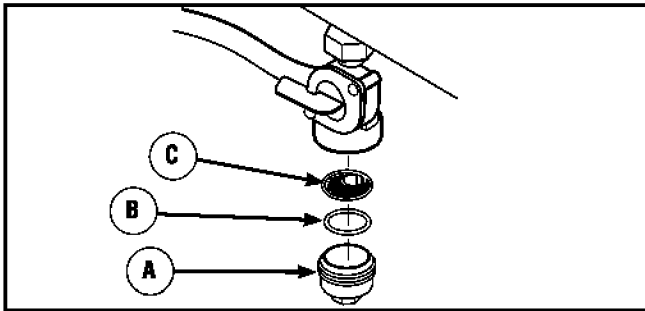

3. Wash sediment cup, o-ring, and screen in a nonflammable solvent. Dry them thoroughly.
4. Place screen and o-ring into fuel valve. Install sediment cup and tighten securely.
5. Move fuel valve to ON (I) position, and check for leaks. Replace fuel valve if there is any leakage.

## Engine Maintenance

**WARNING** Unintentional sparking could cause fire or electric shock resulting in death or serious injury.

### WHEN ADJUSTING OR MAKING REPAIRS TO YOUR GENERATOR

- Disconnect the spark plug wire from the spark plug and place the wire where it cannot contact spark plug.

### WHEN TESTING FOR ENGINE SPARK

- Use approved spark plug tester.
- DO NOT check for spark with spark plug removed.

## Oil

### Oil Recommendations

We recommend the use of Briggs & Stratton Warranty Certified oils for best performance. Other high-quality detergent oils are acceptable if classified for service SF, SG, SH, SJ or higher. DO NOT use special additives.

Outdoor temperatures determine the proper oil viscosity for the engine. Use the chart to select the best viscosity for the outdoor temperature range expected.

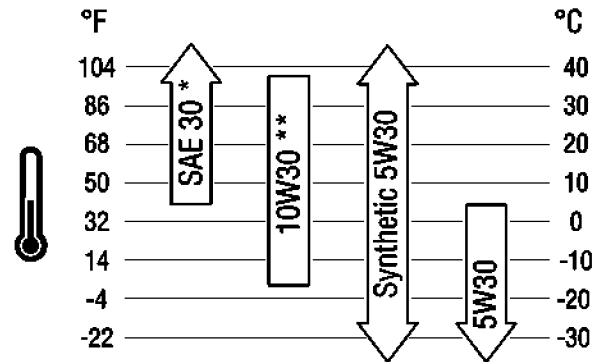

\* Below 40°F (4°C) the use of SAE 30 will result in hard starting.

\*\* Above 80°F (27°C) the use of 10W30 may cause increased oil consumption. Check oil level more frequently.

### Checking Oil Level

Oil level should be checked prior to each use or at least every 8 hours of operation. Keep oil level maintained.

1. Make sure generator is on a level surface.
2. Clean area around oil fill, remove oil cap/dipstick and wipe dipstick with clean cloth. Replace dipstick. Remove and check oil level.

**NOTICE** DO NOT screw in dipstick when checking oil level.

3. Verify oil is at FULL mark (D) on dipstick. Replace and tighten oil cap/dipstick.

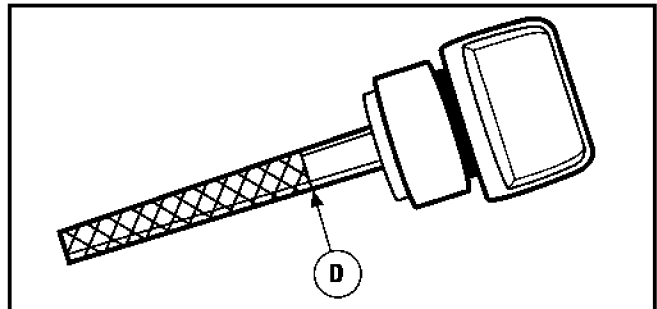

### Adding Engine Oil

1. Make sure generator is on a level surface.
2. Check oil level as described in *Checking Oil Level*.
3. If needed, slowly pour oil into oil fill opening to the FULL mark on dipstick. DO NOT overfill.

**NOTICE** Overfilling with oil could cause the engine to not start, or hard starting.

- DO NOT overfill.
- If over the FULL mark on dipstick, drain oil to reduce oil level to FULL mark on dipstick.

4. Replace and tighten oil cap/dipstick.

## Changing Engine Oil

If you are using your generator under extremely dirty or dusty conditions, or in extremely hot weather, change the oil more often.

**⚠ CAUTION** Avoid prolonged or repeated skin contact with used motor oil.

- Used motor oil has been shown to cause skin cancer in certain laboratory animals.
- Thoroughly wash exposed areas with soap and water.



KEEP OUT OF REACH OF CHILDREN. DON'T POLLUTE. CONSERVE RESOURCES. RETURN USED OIL TO COLLECTION CENTERS.

Change the oil while the engine is still warm from running, as follows:

1. Make sure unit is on a level surface.
2. Disconnect the spark plug wire from the spark plug and place the wire where it cannot contact spark plug.
3. Clean area around oil drain plug (A). The oil drain plug is located at base of engine, opposite carburetor.

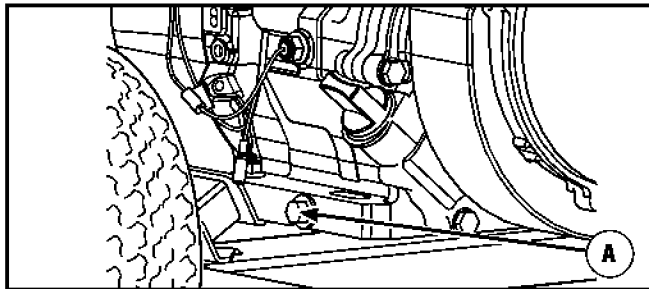

4. Remove oil drain plug and drain oil completely into a suitable container.
5. Reinstall oil drain plug and tighten securely. Remove oil cap/dipstick.
6. Slowly pour recommended oil (about 36 oz. (1 liter)) into oil fill opening. Pause to permit oil to settle. Fill to FULL mark on dipstick.
7. Wipe dipstick clean each time oil level is checked. DO NOT overfill.
8. Reinstall oil cap/dipstick. Tighten cap securely.
9. Wipe up any spilled oil.

## Service Air Cleaner

Your engine will not run properly and may be damaged if you run it with a dirty air cleaner. Clean or replace more often if operating under dusty or dirty conditions.

To service the air cleaner, follow these steps:

1. Loosen screws (B) and remove air cleaner cover (C).

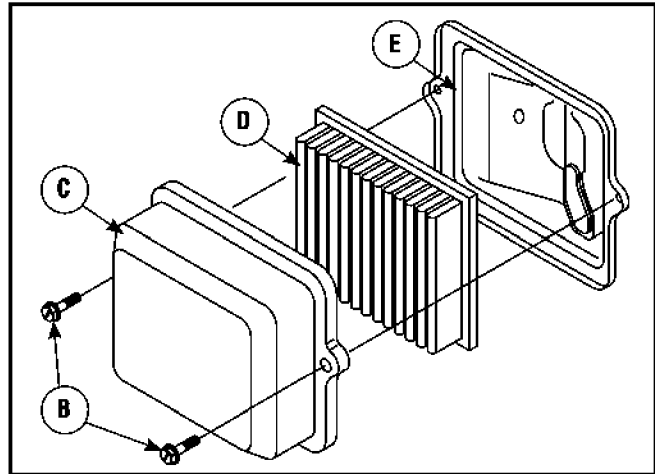

2. Carefully remove cartridge (D) from base (E).
3. Install clean (or new) air cleaner assembly inside cover. Dispose of old filter properly.
4. Assemble air cleaner cover onto base and tighten screws.

## Service Spark Plug

Changing the spark plug will help your engine to start easier and run better.

1. Clean area around spark plug.
2. Remove and inspect spark plug.
3. Check electrode gap with wire feeler gauge and reset spark plug gap to recommended gap if necessary (see *Specifications*).

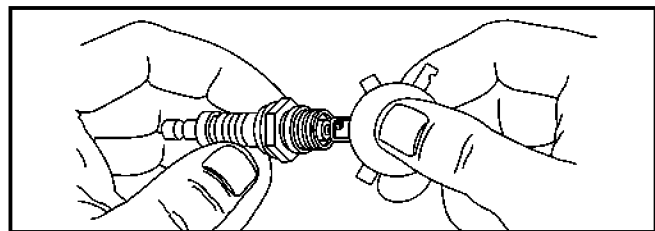

4. Replace spark plug if electrodes are pitted, burned or porcelain is cracked. Use the recommended replacement spark plug. See *Specifications*.
5. Install spark plug and tighten firmly.

## Inspect Muffler and Spark Arrester

The engine exhaust muffler has a spark arrestor screen. Inspect the muffler for cracks, corrosion, or other damage. Inspect spark arrestor screen for damage or carbon blockage. Clean if carbon blockage is found or replace if damaged. If replacement parts are required, make sure to use only original equipment replacement parts.

**⚠ WARNING** Exhaust heat/gases could ignite combustibles, structures or damage fuel tank causing a fire, resulting in death or serious injury.

Contact with muffler area could cause burns resulting in serious injury.

- DO NOT touch hot parts and AVOID hot exhaust gases.
- Allow equipment to cool before touching.
- Keep at least 5 feet (1.5 m) of clearance on all sides of generator including overhead.
- It is a violation of California Public Resource Code, Section 4442, to use or operate the engine on any forest-covered, brush-covered, or grass-covered land unless the exhaust system is equipped with a spark arrestor, as defined in Section 4442, maintained in effective working order. Other states or federal jurisdictions may have similar laws.

Contact the original equipment manufacturer, retailer, or dealer to obtain a spark arrestor designed for the exhaust system installed on this engine.

- Replacement parts must be the same and installed in the same position as the original parts.

## Clean or replace spark arrestor as follows:

1. Remove four screws that connect heat shield (A) to muffler (B).

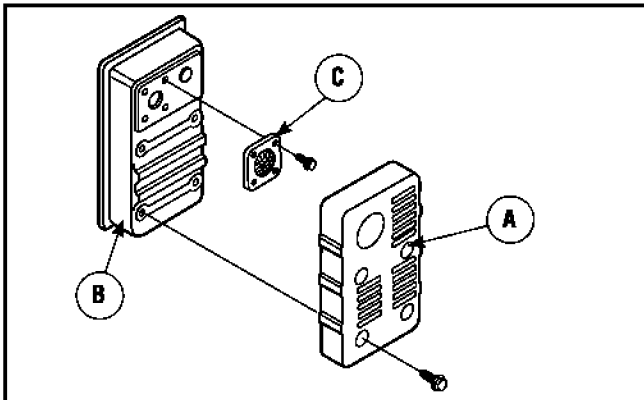

2. Remove four screws that attach spark arrestor screen (C).
3. Obtain a replacement screen if torn, perforated or otherwise damaged. DO NOT use a defective screen. If screen is not damaged, clean it with commercial solvent.
4. Reattach screen and muffler guard.

## Clean Cooling System

Over time debris may accumulate in cylinder cooling fins and cannot be observed without partial engine disassembly. For this reason, we recommend you have a Briggs & Stratton authorized dealer clean the cooling system (D) per recommended intervals (see *Maintenance Schedule* in the *Maintenance* section). Equally important is to keep top of engine free from debris. Also see *Cleaning*.

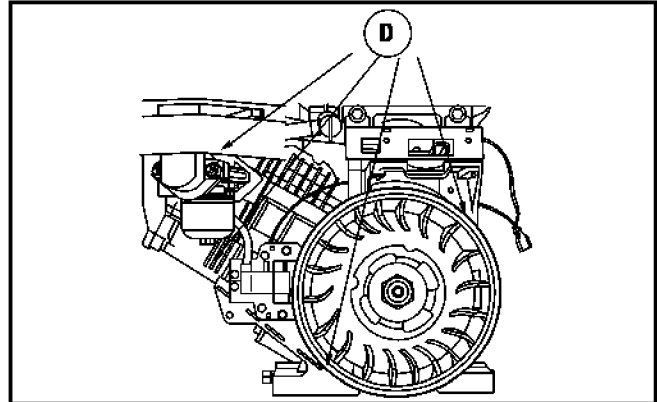

## Carburetor Adjustment

The carburetor on this engine is low emission. It is equipped with a non-adjustable idle mixture valve. Top speed has been set at the factory. If adjustment is required, see a Briggs & Stratton authorized dealer.

**⚠ CAUTION** Excessively high operating speeds could result in minor injury.

Excessively low operating speeds impose a heavy load.

- DO NOT tamper with governor spring, links or other parts to increase engine speed. Generator supplies correct rated frequency and voltage when running at governed speed.
- DO NOT modify generator in any way.



## Storage

The generator should be started at least once every seven days and allowed to run at least 30 minutes. If this cannot be done and you must store the unit for more than 30 days, use the following guidelines to prepare it for storage.

### Generator Storage

- Clean the generator as outlined in *Cleaning*.
- Check that cooling air slots and openings on generator are open and unobstructed.

### Long Term Storage Instructions

Fuel can become stale when stored over 30 days. Stale fuel causes acid and gum deposits to form in the fuel system or on essential carburetor parts. To keep fuel fresh, use Briggs & Stratton® Advanced Formula Fuel Treatment & Stabilizer, available wherever Briggs & Stratton genuine service parts are sold.

For engines equipped with a FRESH START® fuel cap, use Briggs & Stratton FRESH START® available in a drip concentrate cartridge.

There is no need to drain gasoline from the engine if a fuel stabilizer is added according to instructions. Run the engine for 2 minutes to circulate the stabilizer throughout the fuel system before storage.

If gasoline in the engine has not been treated with a fuel stabilizer, it must be drained into an approved container. Run the engine until it stops from lack of fuel. The use of a fuel stabilizer in the storage container is recommended to maintain freshness.

 **WARNING** Fuel and its vapors are extremely flammable and explosive which could cause burns, fire or explosion resulting in death or serious injury.

#### WHEN STORING FUEL OR EQUIPMENT WITH FUEL IN TANK

- Store away from furnaces, stoves, water heaters, clothes dryers or other appliances that have pilot light or other ignition source because they could ignite fuel vapors.

#### WHEN DRAINING FUEL

- Turn generator engine OFF and let it cool at least 2 minutes before removing fuel cap. Loosen cap slowly to relieve pressure in tank.
- Drain fuel tank outdoors.
- Keep fuel away from sparks, open flames, pilot lights, heat, and other ignition sources.
- Check fuel lines, tank, cap and fittings frequently for cracks or leaks. Replace if necessary.
- DO NOT light a cigarette or smoke.

## Change Engine Oil

While engine is still warm, drain oil from crankcase. Refill with recommended grade. See *Changing Engine Oil*.

### Other Storage Tips

1. DO NOT store fuel from one season to another unless it has been treated as described in *Long Term Storage Instructions*.
2. Replace fuel container if it starts to rust. Rust and/or dirt in fuel can cause problems if it's used with this unit.
3. Cover unit with a suitable protective cover that does not retain moisture.

 **WARNING** Storage covers could cause a fire resulting in death or serious injury.

- DO NOT place a storage cover over a hot generator.
- Let equipment cool for a sufficient time before placing the cover on the equipment.

4. Store generator in clean, dry area.

## Troubleshooting

Problem	Cause	Correction
Engine is running, but no AC output is available.	<ol style="list-style-type: none"> <li>1. One of the circuit breakers is open.</li> <li>2. Fault in generator.</li> <li>3. Poor connection or defective cord set.</li> <li>4. Connected device is bad.</li> </ol>	<ol style="list-style-type: none"> <li>1. Reset circuit breaker.</li> <li>2. Contact authorized service facility.</li> <li>3. Check and repair.</li> <li>4. Connect another device that is in good condition.</li> </ol>
Engine runs good at no-load but "bogs down" when loads are connected.	<ol style="list-style-type: none"> <li>1. Short circuit in a connected load.</li> <li>2. Engine speed is too slow.</li> <li>3. Generator is overloaded.</li> <li>4. Shorted generator circuit.</li> <li>5. Clogged or dirty fuel filter.</li> </ol>	<ol style="list-style-type: none"> <li>1. Disconnect shorted electrical load.</li> <li>2. Contact authorized service facility.</li> <li>3. See <i>Don't Overload Generator</i>.</li> <li>4. Contact authorized service facility.</li> <li>5. Clean or replace fuel filter.</li> </ol>
Engine will not start, starts and runs rough or shuts down when running.	<ol style="list-style-type: none"> <li>1. Start switch in OFF (0) position.</li> <li>2. Fuel valve is in OFF (0) position.</li> <li>3. Failed battery.</li> <li>4. Low oil level.</li> <li>5. Dirty air cleaner.</li> <li>6. Clogged or dirty fuel filter.</li> <li>7. Out of fuel.</li> <li>8. Stale fuel.</li> <li>9. Spark plug wire not connected to spark plug.</li> <li>10. Bad spark plug.</li> <li>11. Water in fuel.</li> <li>12. Flooded.</li> <li>13. Excessively rich fuel mixture.</li> <li>14. Intake valve stuck open or closed.</li> <li>15. Engine has lost compression.</li> </ol>	<ol style="list-style-type: none"> <li>1. Turn key in start switch to run (I).</li> <li>2. Turn fuel valve to ON (I) position.</li> <li>3. Replace battery.</li> <li>4. Fill crankcase to proper level or place generator on level surface.</li> <li>5. Clean or replace air cleaner.</li> <li>6. Clean or replace fuel filter.</li> <li>7. Fill fuel tank.</li> <li>8. Drain fuel tank and carburetor; fill with fresh fuel.</li> <li>9. Connect wire to spark plug.</li> <li>10. Replace spark plug.</li> <li>11. Drain fuel tank and carburetor; fill with fresh fuel.</li> <li>12. Wait 5 minutes and re-crank engine.</li> <li>13. Contact authorized service facility.</li> <li>14. Contact authorized service facility.</li> <li>15. Contact authorized service facility.</li> </ol>
Engine lacks power.	<ol style="list-style-type: none"> <li>1. Load is too high.</li> <li>2. Dirty air filter.</li> <li>3. Clogged or dirty fuel filter.</li> </ol>	<ol style="list-style-type: none"> <li>1. See <i>Don't Overload Generator</i>.</li> <li>2. Replace air filter.</li> <li>3. Clean or replace fuel filter.</li> </ol>
Engine "hunts" or falters.	<ol style="list-style-type: none"> <li>1. Carburetor is running too rich or too lean.</li> <li>2. Clogged or dirty fuel filter.</li> </ol>	<ol style="list-style-type: none"> <li>1. Contact authorized service facility.</li> <li>2. Clean or replace fuel filter.</li> </ol>



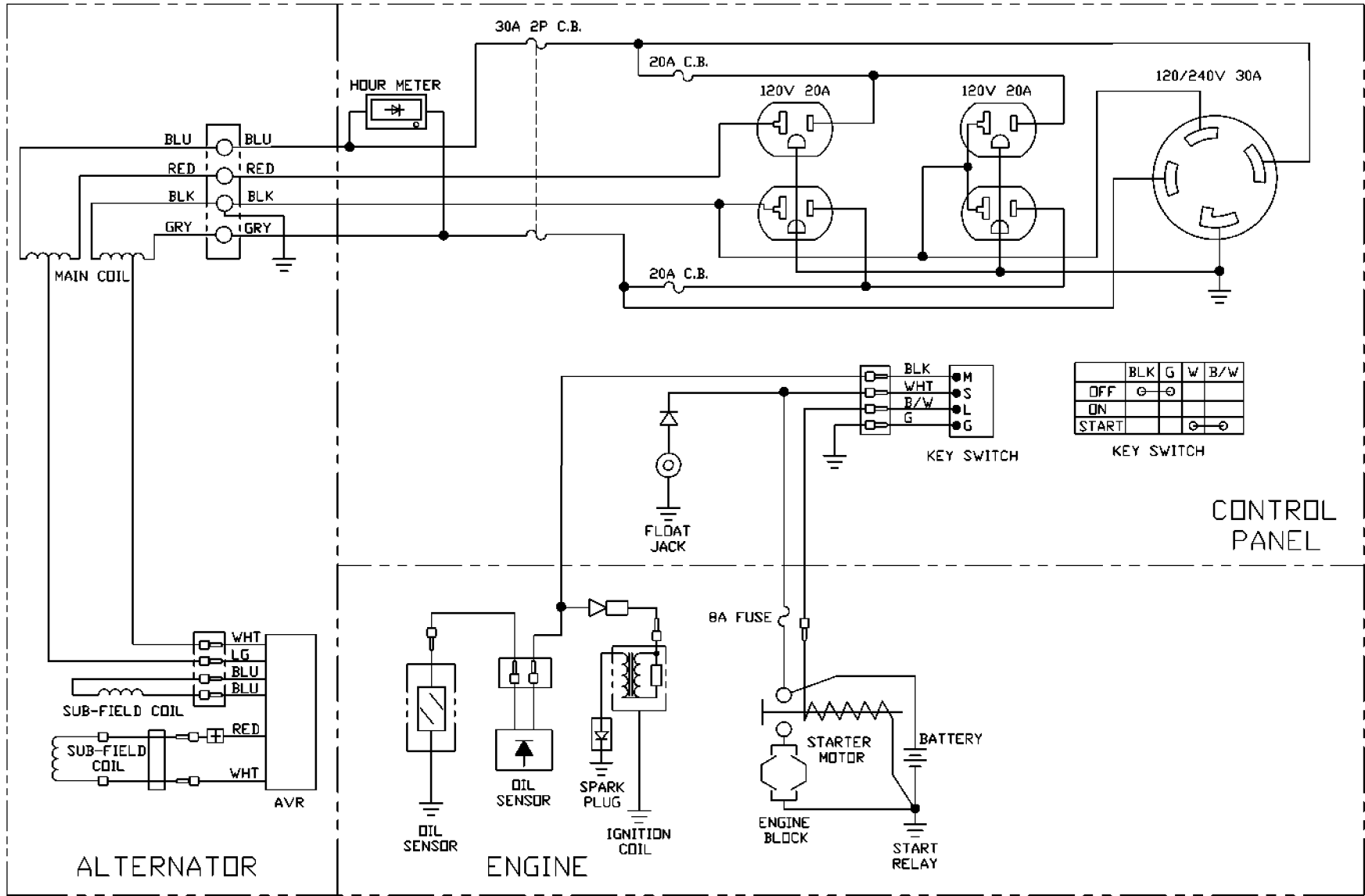

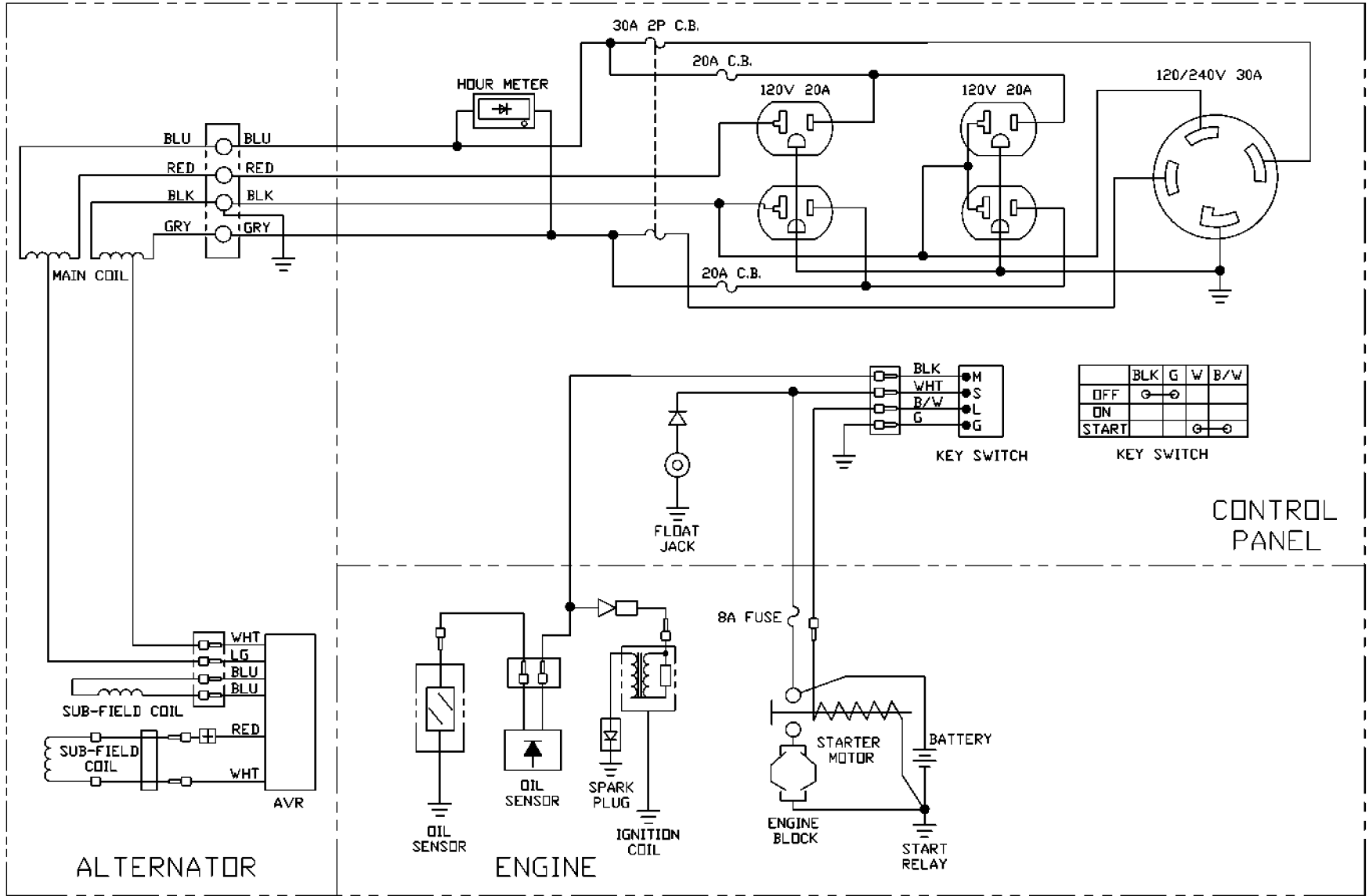

## BRIGGS & STRATTON POWER PRODUCTS GROUP, LLC PORTABLE GENERATOR OWNER WARRANTY POLICY

### LIMITED WARRANTY

Briggs & Stratton warrants that, during the warranty period specified below, it will repair or replace, free of charge, any part that is defective in material or workmanship or both. Transportation charges on product submitted for repair or replacement under this warranty must be borne by purchaser. This warranty is effective for and is subject to the time periods and conditions stated below. For warranty service, find the nearest Authorized Service Dealer in our dealer locator map at BRIGGSandSTRATTON.com. The purchaser must contact the Authorized Service Dealer, and then make the product available to the Authorized Service Dealer for inspection and testing.

**There is no other express warranty. Implied warranties, including those of merchantability and fitness for a particular purpose, are limited to one year from purchase, or to the extent permitted by law. All other implied warranties are excluded. Liability for incidental or consequential damages are excluded to the extent exclusion is permitted by law.** Some states or countries do not allow limitations on how long an implied warranty lasts, and some states or countries do not allow the exclusion or limitation of incidental or consequential damages, so the above limitation and exclusion may not apply to you. This warranty gives you specific legal rights and you may also have other rights which vary from state to state or country to country.\*\*

### WARRANTY PERIOD

	Engine	All other components
<b>Consumer Use</b>	<b>2 years</b>	<b>3 years*</b>
<b>Commercial Use</b>	<b>1 year</b>	<b>1 year</b>

\*Year 2 & 3 parts only

\*\* In Australia - Our goods come with guarantees that cannot be excluded under the Australian Consumer Law. You are entitled to a replacement or refund for a major failure and for compensation for any other reasonably foreseeable loss or damage. You are also entitled to have the goods repaired or replaced if the goods fail to be of acceptable quality and the failure does not amount to a major failure. For warranty service, find the nearest Authorized Service Dealer in our dealer locator map at BRIGGSandSTRATTON.COM, or by calling 1300 274 447, or by emailing or writing to salesenquires@briggsandstratton.com.au, Briggs & Stratton Australia Pty Ltd, 1 Moorebank Avenue, NSW, Australia, 2170.

The warranty period begins on the date of purchase by the first retail end user, and continues for the period of time stated above. "Consumer Use" means personal residential household use by a retail consumer. "Commercial Use" means all other uses, including use for commercial, income producing or rental purposes. Once equipment has experienced commercial use, it shall thereafter be considered as commercial use for purposes of this warranty. Equipment used for prime power in place of utility are not applicable to this warranty.

**NO WARRANTY REGISTRATION IS NECESSARY TO OBTAIN WARRANTY ON BRIGGS & STRATTON PRODUCTS. SAVE YOUR PROOF OF PURCHASE RECEIPT. IF YOU DO NOT PROVIDE PROOF OF THE INITIAL PURCHASE DATE AT THE TIME WARRANTY SERVICE IS REQUESTED, THE MANUFACTURING DATE OF THE PRODUCT WILL BE USED TO DETERMINE THE WARRANTY PERIOD.**

### ABOUT YOUR WARRANTY

We welcome warranty repair and apologize to you for being inconvenienced. Any Authorized Service Dealer may perform warranty repairs. Most warranty repairs are handled routinely, but sometimes requests for warranty service may not be appropriate. For example, warranty service would not apply if equipment damage occurred because of misuse, lack of routine maintenance, shipping, handling, warehousing or improper installation. Similarly, the warranty is void if the manufacturing date or the serial number on the portable generator has been removed or the equipment has been altered or modified. During the warranty period, the Authorized Service Dealer, at its option, will repair or replace any part that, upon examination, is found to be defective under normal use and service. This warranty will not cover the following repairs and equipment:

- **Normal Wear:** Outdoor Power Equipment, like all mechanical devices, needs periodic parts and service to perform well. This warranty does not cover repair when normal use has exhausted the life of a part or the equipment.
- **Installation and Maintenance:** This warranty does not apply to equipment or parts that have been subjected to improper or unauthorized installation or alteration and modification, misuse, negligence, accident, overloading, overspeeding, improper maintenance, repair or storage so as, in our judgment, to adversely affect its performance and reliability. This warranty also does not cover normal maintenance such as adjustments, fuel system cleaning and obstruction (due to chemical, dirt, carbon, lime, etc.).
- **Other Exclusions:** This warranty excludes wear items such as o-rings, filters, etc., or malfunctions resulting from accidents, abuse, modifications, alterations, or improper servicing or freezing or chemical deterioration. Accessory parts such as starting batteries, generator adapter cord sets and storage covers are excluded from the product warranty. This warranty excludes used, reconditioned, and demonstration equipment, equipment used for prime power in place of utility power, equipment used in life support applications, and failures due to acts of God and other force majeure events beyond the manufacturers control. 311527E, Rev. C, 10/28/2013

**BRIGGS & STRATTON POWER PRODUCTS GROUP, LLC**

**MILWAUKEE, WI, USA**