

**INSTALLATION & OPERATING
INSTRUCTIONS for
SPLIT SYSTEM
CONDENSING UNITS**

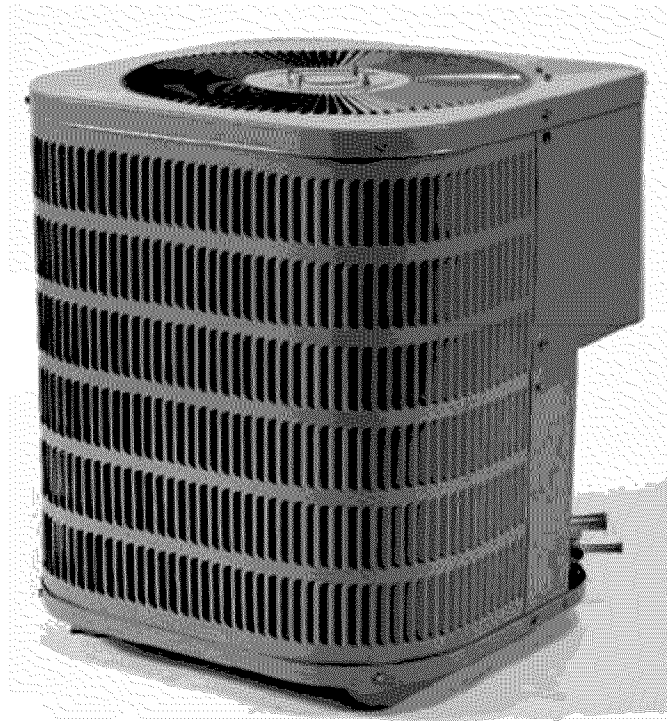

All information contained herein is subject to change without notice.

Made in the USA by:

Goodman Manufacturing Company, L.P.

2550 North Loop West, Suite 400, Houston, TX 77092

www.goodmanmfg.com or amana-hac.com

© 2004-2005 Goodman Manufacturing Company, L.P.

INDEX

Important Message to Homeowner	2
Codes and Regulations	2
Inspection	2
Replacement Parts	2
Important Safety Instructions	2
Clearances and Accessibility	2
Location	3
Electrical	4
Refrigerant Tubing	4
Evaporator Coils	4
Quick Connect Coils	4
System Start Up	4
Processing Checks	4
Charge Checks	5
Superheat Determination	5
Expansion Valve System	5
Wiring Diagrams	7

IMPORTANT MESSAGE TO OWNER

These instructions should be carefully read and kept near product, for future reference. While these instructions are addressed primarily to the installer, useful maintenance information is included. Have your installing dealer acquaint you with the operating characteristics of the product and periodic maintenance requirements.

CODES AND REGULATIONS

This product is designed and manufactured to permit installation in accordance with National Codes. It is the installers responsibility to install the product in accordance with National Codes and/or prevailing local codes and regulations. The manufacturer assumes no responsibility for equipment installed in violation of any code or regulations.

Important: The United States Environmental Protection Agency (EPA) has issued various regulations regarding the introduction and disposal of refrigerants in this unit. Failure to follow these regulations may harm the environment and can lead to the imposition of substantial fines. Because regulations may vary due to passage of new laws, we suggest a certified technician perform any work done on this unit. Should you have any questions please contact the local office of the EPA.

INSPECTION

Upon receiving the unit, inspect it for damage from shipment. Claims for damage, either shipping or concealed, should be filed immediately with the shipping company. Check the unit model number, specifications, electrical characteristics and accessories to determine if they are correct. In the event an incorrect unit is shipped, it must be returned to

the supplier and must NOT be installed. The manufacturer assumes no responsibility for installation of incorrectly shipped units.

REPLACEMENT PARTS

Order all replacement parts through your local distributor. When ordering parts, give complete model and serial number as shown on the unit's rating plate. Replacement parts for this appliance are available through your contractor or local distributor. For the location of your nearest distributor consult the white business pages, the yellow page section of the local telephone book or contact:

SERVICE PARTS DEPARTMENT
GOODMAN MANUFACTURING COMPANY, L.P.
2550 NORTH LOOP WEST, SUITE 400
HOUSTON, TEXAS 77092
(713) 861 – 2500

IMPORTANT SAFETY INSTRUCTIONS

Recognize Safety Symbols, Words, and Labels

The following symbols and labels are used throughout this manual to indicate immediate or potential hazards. It is the owner's and installer's responsibility to read and comply with all safety information and instructions accompanying these symbols. Failure to heed safety information increases the risk of property damage and/or product damage, serious personal injury or death.



DANGER

IMMEDIATE HAZARDS WHICH **WILL** RESULT IN PROPERTY DAMAGE, PRODUCT DAMAGE, SEVERE PERSONAL INJURY OR DEATH.



WARNING

HAZARDS OR UNSAFE PRACTICES **COULD** RESULT IN PROPERTY DAMAGE, PRODUCT DAMAGE, SEVERE PERSONAL INJURY OR DEATH.



CAUTION

HAZARDS OR UNSAFE PRACTICES WHICH **MAY** RESULT IN PROPERTY DAMAGE, PRODUCT DAMAGE, PERSONAL INJURY OR DEATH.

CLEARANCES AND ACCESSIBILITY

The condensing unit is designed to be located outside the building with unobstructed condenser air inlet and discharge. Additionally, the unit must be situated to permit access for service and installation. Condenser air enters from three sides. Air discharges upward from the top of the unit. Refrigerant tube electrical connections are made on the right side of the unit as you face the compressor compartment. The best and most common application is for the unit to be located 10" from the back wall with the connection side facing the wall. Refer to Figures 1 and 2. This "close to the wall" application minimizes exposed tubing and wiring and reduces the space for children to run around the unit. This will help to avoid possible damage to the tubes or wiring and/or personal injury.

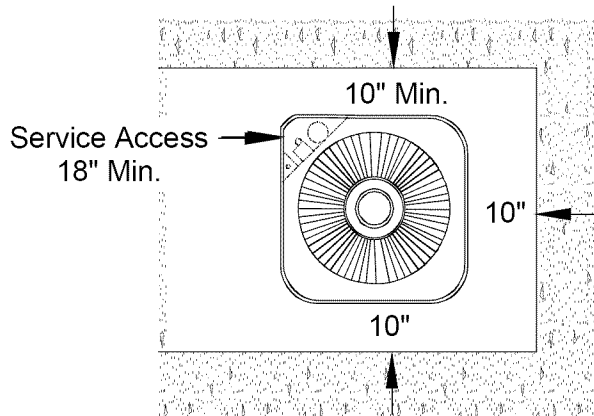
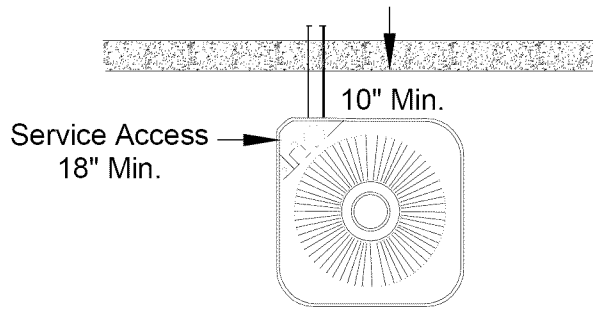

FIGURE 1

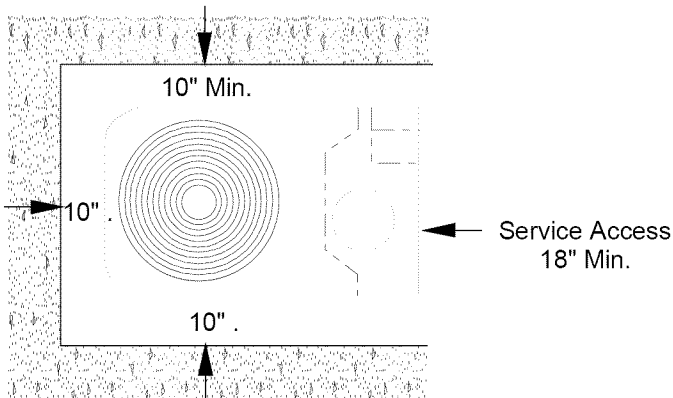
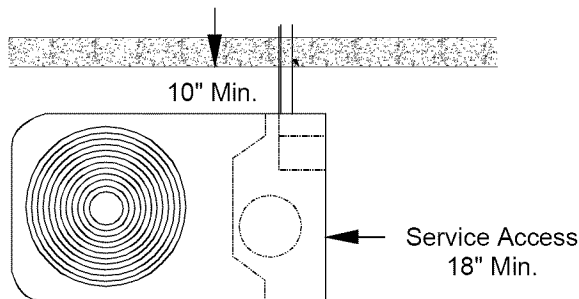

FIGURE 2

Close to the wall application assures free, unobstructed air to the other two sides. In more confined application spaces, such as corners, provide a minimum 10" clearance on all air inlet sides. Allow 18" minimum for service access to the compressor compartment and controls.

The top of the unit should be completely unobstructed. If units are to be located under an overhang, there should be a minimum of 36" clearance and provisions made to deflect the warm discharge air out from the overhang.

LOCATION

If unit is to be located under an overhang, there should be a minimum of 36" clearance and provisions made to deflect the warm discharge air out from the overhang. If the outdoor unit is mounted above the air handler, the maximum lift should not exceed 70' (suction line). If air handler is mounted above condensing unit, the lift should not exceed 50' (liquid line.). Refer to Figure 3 and Table 1 for maximum refrigerant line lengths.

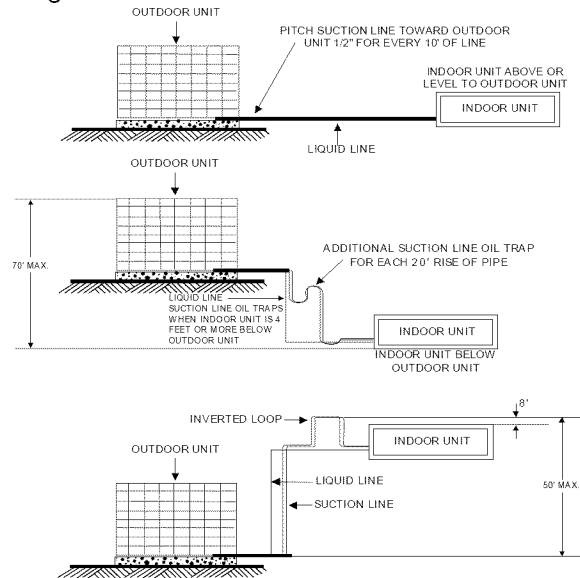

FIGURE 3

REFRIGERANT LINE LENGTH (Ft)						
Cond Unit Tons	0-24		25-49		50-74***	
	Line Diameter (In. OD)					
	Suct	Liq	Suct	Liq	Suct	Liq
1 1/2	5/8	1/4	3/4	3/8	3/4**	3/8
2	3/4	3/8	3/4	3/8	3/4**	3/8
2 1/2	3/4	3/8	3/4*	3/8	7/8**	1/2
3	3/4	3/8	3/4**	3/8	7/8**	1/2
3 1/2	3/4	3/8	7/8**	3/8	1 1/8	1/2
4	7/8	3/8	1 1/8	3/8	1 1/8	1/2
5	7/8	3/8	1 1/8	3/8	1 1/8	1/2

* 7/8" required for full ratings

** 1 1/8" required for full ratings

*** Lines greater than 75' in length or changing elevation more than 50' **require additional engineering** - contact your local distributor

NOTE: This chart is for straight tubing only and assumes long radius fittings. It is not an "equivalent footage" type chart.

TABLE 1

The condensing unit must be mounted on a solid, level

foundation, i.e. pre-formed concrete slab or other suitable base. For rooftop application, make sure the building construction can support the weight and that proper consideration is given to the weather-tight integrity of the roof. The condensing unit contains moving components and can vibrate; therefore, sound is also a consideration in rooftop application. Since this unit discharges warm condenser air from the top with cooler air being drawn in three sides, plantings can be made in relatively close proximity to the unit. Owners should be advised to avoid lawn mower discharge toward the unit depositing debris on the fan coil surface reducing product efficiency.

ELECTRICAL

WARNING

DISCONNECT ALL POWER TO THE UNIT BEFORE INSTALLING OR SERVICING. FAILURE TO FOLLOW THIS WARNING MAY RESULT IN PROPERTY DAMAGE, PERSONAL INJURY OR DEATH DUE TO ELECTRICAL SHOCK.

Electrical installation will consist of power supply wiring to the condensing unit as well as control wiring between thermostat, indoor unit and the condensing unit as shown on wiring diagram. All wiring must be in accordance with National Electrical Code and/or local codes that may apply.

The condensing unit rating plate and the table inside the front cover of this instruction lists pertinent electrical data necessary for the selection of proper size electrical service and over-current protection. The owner should be made familiar with the location of the over-current protection, the proper size for this application and the proper procedure for disconnecting power service to the unit.

The condensing unit control wiring requires a 24 Volt minimum 25 VA service from the indoor transformer as shown on the wiring diagram.

REFRIGERANT TUBING

Use only refrigerant grade (dehydrated and sealed) copper tubing of the size indicated in Table 1 to interconnect the condensing unit with the indoor evaporator. Take extreme care to keep the refrigerant tubing clean and dry prior to and during installation.

Do not remove plugs from ends of tubing until connection is ready to be made. Suction line insulation is necessary to prevent condensation from forming on and dripping from suction line. Generally 3/8" wall thickness of *Armflex* or equivalent is satisfactory. In severe application (hot, high humidity areas) greater thickness may be required. Apply suction line insulation by sliding it on the sealed tubing before cutting and making connections.

EVAPORATOR COILS

WARNING

USE EXTREME CARE IN REMOVING THE CAPS FROM THE SUCTION AND LIQUID LINE FITTINGS AS THERE IS PRESSURE PRESENT. A FITTING IS ON THE LIQUID LINE TO REMOVE PRESSURE.

WARNING

DO NOT REMOVE PROTECTIVE CAPS UNTIL INSTALLATION HAS BEEN COMPLETED AND FINAL CONNECTIONS ARE TO BE MADE.

Field Connection to the Valve and Valve Opening

1. Tubing should be cut square. Make sure it is round and free of burrs at the connecting ends. Clean the tubing to prevent contaminants from entering the system.
2. Wrap a wet rag around the copper valve stub before brazing.
3. Braze or silver solder the joint.
4. After brazing, quench with a wet rag to cool the joint. Evacuate and charge the connecting lines as outlined in these instructions.
5. Remove valve top cap. It is important to keep the cap in a clean area to assure proper sealing once replaced.
6. Using a standard L shaped Allen wrench, break open the valve body. To expedite opening the valve body after it is broken, use a ratchet wrench with a short Allen stub. Please note that it is normal to see oil on the valve stem body once the cap is removed.
7. Replace the valve cap and tighten with a wrench making sure that the the cap is sealed.

QUICK CONNECT COILS

Precharged System Installation

Installation procedure will differ when condensing units are provided for use with precharged refrigerant coils and lines. Condensing units are provided with #6 and #11 male quick connects instead of liquid and suction valves attached to cabinet to contain the R-22 charge that is sufficient for matching evaporator coils and 15' of interconnecting lines.

Coils are provided with #6 and #11 male quick connects. Line sets are required with #6 and #11 female quick connects on both ends. Access ports are required in the fittings of both liquid and suction lines at condenser end. Both coil and line sets include R-22 holding charge only.

1. Connect lines to evaporator coil before connecting to the condensing unit locating access ports adjacent to condensing unit.
 - a. Form tubing so it properly aligns with the coil connections.
 - b. Remove plugs and caps from connections.
 - c. Check to be sure mating surfaces are clean.
 - d. Lubricate rubber seal with clean refrigerant oil and thread couplings together by hand to be sure they are not cross threaded.

- e. Tighten connections using backup wrench on stationary fitting until coupling bottoms; then tighten 1/6 turn to complete knife edge seal.
2. Connect lines to condensing unit in the same manner as to evaporator coil. Observe same precautions.
3. After making all connections and opening valves, check all piping for leaks.

SYSTEM START UP

Processing Checks

Condensing units are supplied R-22 charge sufficient for typical matching evaporator and approximately 15' of interconnecting tubing. Condensing unit liquid and suction valves are closed to contain the charge within the unit.

The recommended procedure for processing and charge adjustment is as follows:

1. Connect vacuum pump to both base valve service ports.
2. Evacuate tubing and evaporator through liquid and suction base valve ports, to 500 microns or less for a minimum of 30 minutes. Close valve to pump and wait 15 minutes. Vacuum should not rise above 800 microns. If unable to obtain 500 microns, or vacuum rises above 800 microns over a 15 minute period, discontinue evacuation, pressurize and check for leaks. Repair any leaks found and repeat step 2.
3. Close valve to vacuum pump and stop pump. Break vacuum by opening liquid and suction base valves. Fully open base valves and remove pump lines. Connect service gauges making sure lines are purged.
4. Set thermostat system switch to "COOL" and temperature to highest setting. Close all disconnects.
5. Set thermostat to call for cooling. Check for operation of indoor and outdoor fans. Allow a minimum of 10 minutes for the system to operate before making any refrigerant adjustment.
6. Check charge and adjust if necessary. Refer to appropriate "Check Charge" section.

Charge Checks

Capillary Tube/Fixed Orifice System

1. Fully open both base valves.
2. Connect service gauge manifold to base-valve service ports being sure to purge lines. Run system at least 10 minutes to allow pressure to stabilize.
3. Temporarily install thermometer on suction (large) line near condensing unit. Be sure of good contact between the thermometer and line. Wrap thermometer with insulating material to assure accurate reading.
4. Refer to Table 2 for proper system superheat. Add charge to lower superheat. Remove charge to raise superheat.
5. Remove gauge lines carefully.



WARNING

ESCAPING LIQUID REFRIGERANT CAN CAUSE BURNS.

SYSTEM SUPERHEAT					
AMBIENT CONDENSER INLET TEMPERATURE °F DRYBULB	RETURN AIR TEMPERATURE (°F DRYBULB)				
	65	70	75	80	85
	100				5
95			5	5	5
90			7	12	18
85		5	10	17	20
80		5	12	21	26
75	5	10	17	25	29
70	5	14	20	28	32
65	13	19	26	32	35
60	17	25	30	33	37

TABLE 2

Superheat Determination

1. Read suction pressure. Using Table 3, determine saturated suction temperature.
2. Read suction line temperature.
3. Use the following formula to determine superheat:

Superheat = Suction Line Temp. - Saturated Suction Temp.

SATURATED SUCTION PRESSURE (R-22)	
SUCTION PRESSURE PSIG	SATURATED SUCTION TEMPERATURE °F
50	26
53	28
55	30
58	32
61	34
63	36
66	38
69	40
72	42
75	44
78	46
81	48

TABLE 3

Expansion Valve System

1. Fully open both base valves.
2. Connect service gauge manifold to base-valve service parts making sure lines are purged. Run system at least 10 minutes to allow pressure to stabilize.
3. Temporarily install the thermometer to liquid (small) line near condensing unit. Be sure that the contact between thermometer and line is good. Wrap thermometer with insulating material to ensure accurate reading.
4. Referring to Table 4, adjust charge to obtain a temperature 12-15°F below the saturated liquid temperature.

Example:

If the Liquid Pressure is 260 PSIG then the Saturated Temperature will be 120°F. Adjust the Saturated Temperature by subtracting 12-15°F. This will give you a Liquid Line Temperature of 105° - 108°F.

SATURATED LIQUID TEMPERATURE	
LIQUID PRESSURE (PSIG)	SATURATED TEMPERATURE °F
200	102
210	105
220	108
230	111
240	114
250	117
260	120
270	123
280	126
290	128
300	131

TABLE 4

SPECIAL NOTE: Systems with MORE than 15' of interconnecting tubing, please refer to Table 5 for line charge

allowance per foot of tubing.

LINE CHARGE ALLOWANCE (R-22) (oz./ft.)		
LINE O. D. (IN)	LIQUID LINE	SUCTION LINE
1/4	0.22	
3/8	0.58	
1/2	1.14	
5/8	1.86	0.04
3/4		0.06
7/8		0.08
1 1/8		0.15
1 3/8		0.22

TABLE 5

NOTE: System with over 50' separation between condensing unit and evaporator may require oil charge adjustment.

OIL CHARGE ADJUSTMENT	
UNIT MODEL (TONS)	ADDITIONAL OIL CHARGE PER EACH ADDITIONAL 10' OF LINE (OZ.)*
1 - 1 1/2	0.25
2 - 5	0.5

*Use either Texaco WF-32 (formerly cappella B) or Suniso 3G-S oil

TABLE 6

WIRING DIAGRAMS

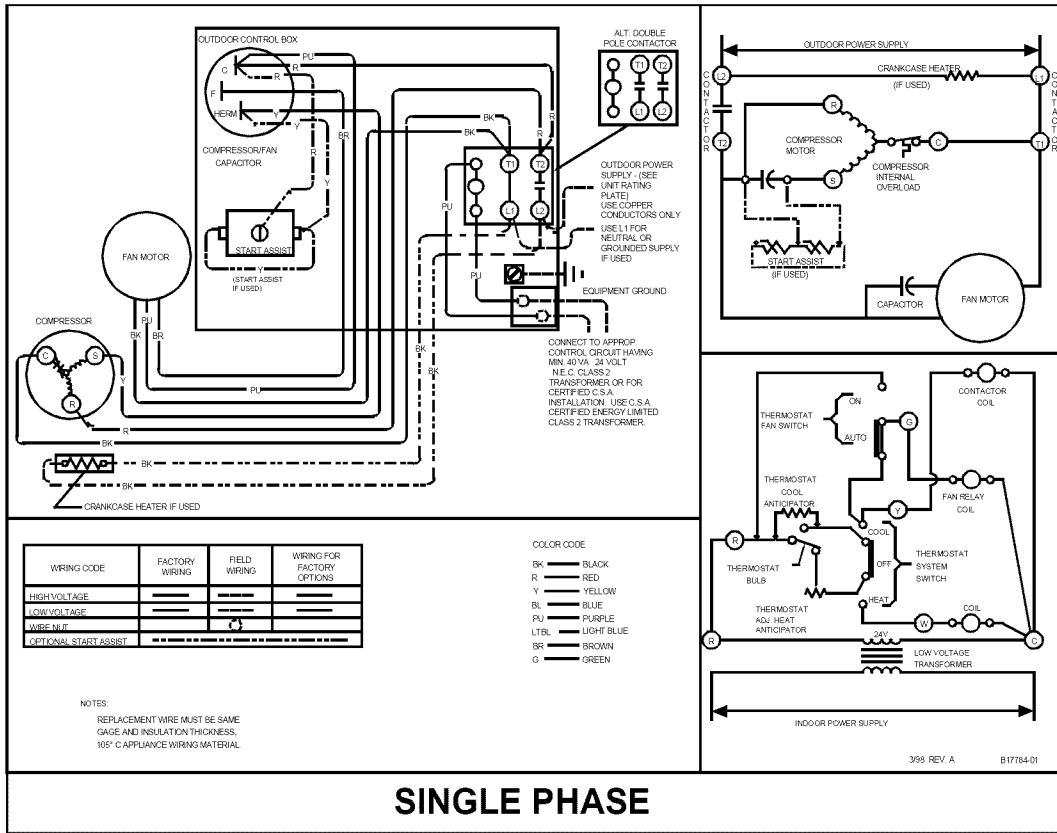

SINGLE PHASE

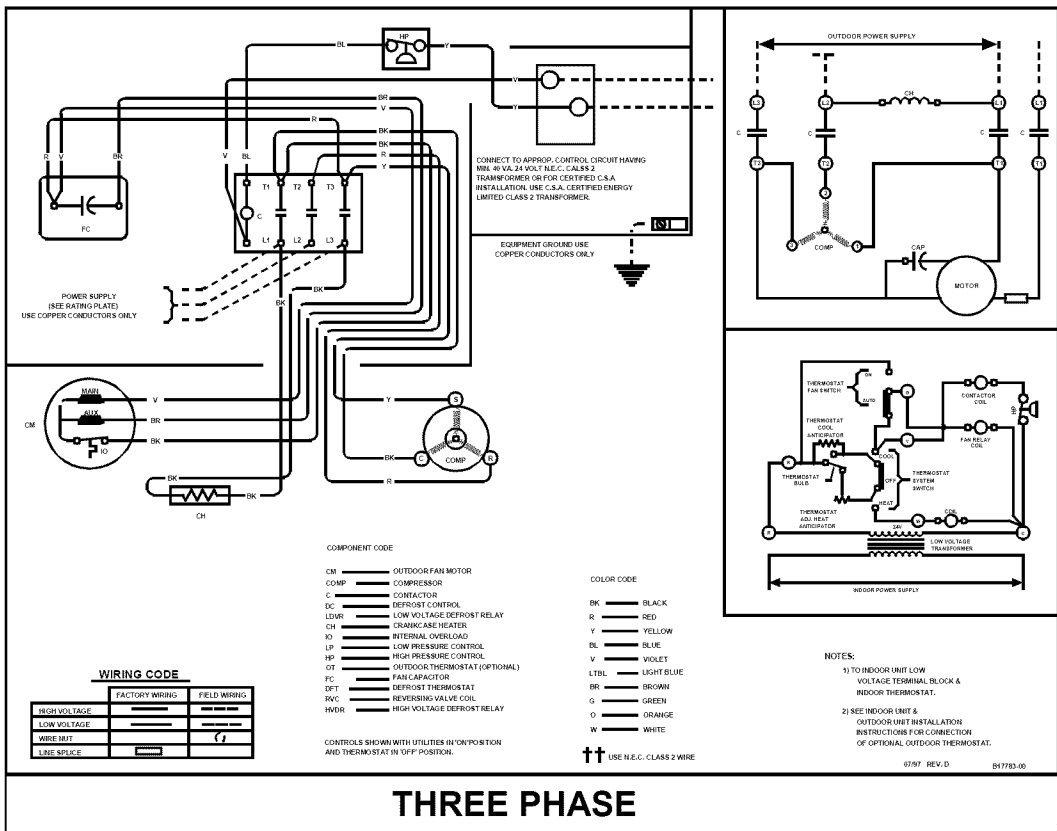

THREE PHASE

**NOTE: SPECIFICATIONS AND PERFORMANCE DATA LISTED HEREIN
ARE SUBJECT TO CHANGE WITHOUT NOTICE**

Quality Makes the Difference!

All of our systems are designed and manufactured with the same high quality standards regardless of size or efficiency. We have designed these units to significantly reduce the most frequent causes of product failure. They are simple to service and forgiving to operate. We use quality materials and components. Finally, every unit is run tested before it leaves the factory. That's why we know. . . **There's No Better Quality.**

Visit our website at www.goodmanmfg.com for information on:

- Goodman products
- Warranties
- Customer Services
- Parts
- Contractor Programs and Training
- Financing Options