

Kenmore®

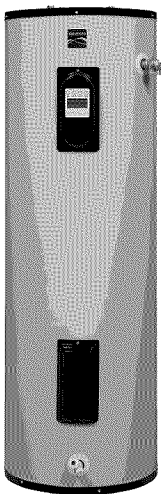

Quick Start & Install Guide
Smart Water Heater Module



To get started,
you need your
Kenmore® Smart Water Heater Module
With Leak Detection Module (included),
A Kenmore® Connected Ready Water Heater,
A wireless router with working internet connection
and a smartphone.

It's easy!





Preparation

Before you start the installation, here is what you will need:

- Kenmore® Smart Water Heater Module with Leak Detector
- Home router with internet access
- iOS or Android smartphone
- #2 Phillips screwdriver, and
- One of these Kenmore® water heater models (as listed on the water heater's rating label):
153.582400, 153.582500, 153.589400,
153.589500, 153.592500, 153.592600,
or 153.592800
- Kenmore® Smart Water Heater Use and Care Guide



Preparation

(Cont'd)

Note the locations of the various key features of the Kenmore® Smart Water Heater Module:

Control Button:

- Connect Smart
- Leak Detector Reset

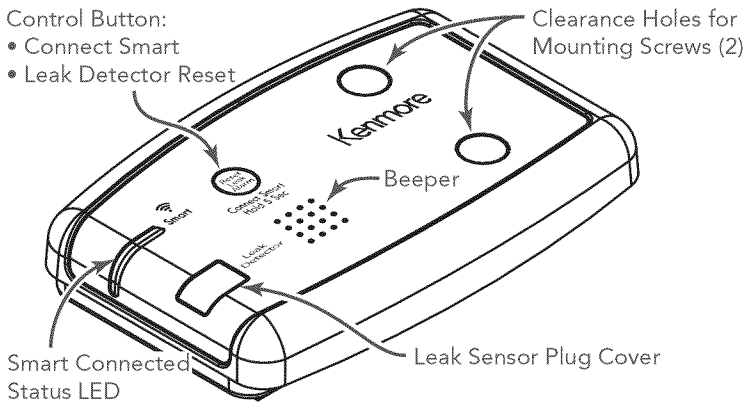

Figure 1

2

Install the Smart Water Heater Module

WARNING! Working on an energized circuit can result in severe injury or death from electrical shock. Turn power off before performing this installation. Check wires with a non-contact circuit tester to make sure power is off.

If you have a smart electric water heater, follow these steps:

Step 1: Turn power off at source (circuit breaker).

Step 2: Remove access cover. Discard screws. Longer screws are provided.

Step 3: Plug in module.

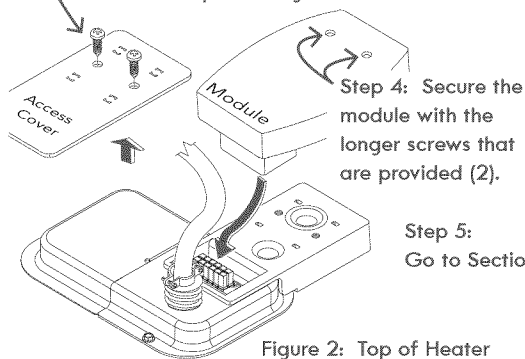

NOTICE: Do not turn power on unless screws are installed as described in Step 4 above. Screws must be installed to prevent equipment damage.

2

Install the Smart Water Heater Module

(Cont'd)

If you have a heat pump water heater, follow these steps:

Step 1: Turn power off at source (circuit breaker).

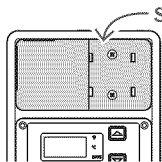

Step 2: Remove plug access cover. Discard screws. Longer screws are provided.

Step 3: Plug in module.

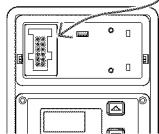
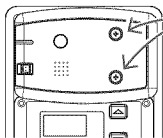

Figure 3:
Control panel shown;
Located on front of
water heater.



Step 4: Secure the module with the longer screws that are provided (2).

Step 5: Go to Section 3.

NOTICE: Do not turn power on unless screws are installed as described in Step 4 above. Screws must be installed to prevent equipment damage.

3

Install the Leak Sensor

- Step 1: Remove the leak sensor plug cover. See Figure 1.
- Step 2: Plug the sensor's connector into the module. See Figure 4.
- Step 3: Peel the backing off of the sensor's adhesive tape (located on the back of the sensor).

IMPORTANT: The sensor must be mounted to a surface that is clean and dry.

- Step 4: Secure the sensor to the bottom edge of the water heater or the inside rim of the drain pan (Figure 4). Be sure that the two metal pins (opposite the wires) are placed slightly above the floor of the drain pan. For the sensor to work properly, the extensions must be located where water will fill the gap between them.
- Step 5: Peel the backing off the tape on one of the wire clips. Attach the clip to the water heater, close to the leak sensor, as shown in Figure 4. Open the clip, insert the wires, then close the clip.

Repeat at the middle of the water heater, then at the top (near the module).

NOTE: The wire clips must be mounted to a surface that is clean and dry.

Figure 4:
Leak Sensor
Installation

- **IMPORTANT:** Read the instructions before attaching the sensor.
- Figure shows installation on a smart electric water heater. Use the same procedure for a heat pump water heater.

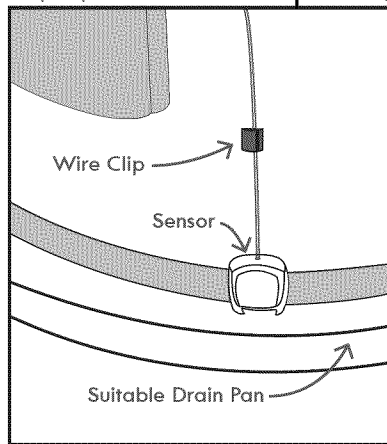
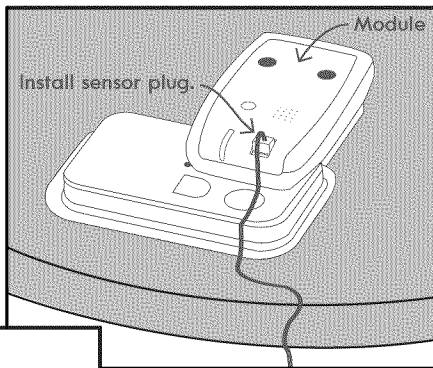

4

Turn on Power

If you are installing the Kenmore® Smart Water Heater Module on one of these models, turn your water heater on according to its use and care guide, then go to Section 5:

- 153.582400
- 153.582500
- 153.592500
- 153.592600
- 153.592800

If you are installing the module on model 153.589400 or 153.589500, turn your water heater on according to its use and care guide, then go to Section 6.

5

Enable the Water Heater

Follow these steps if you have a smart electric water heater with a control panel (shown below).

If you have a heat pump water heater, skip these steps and go to the next page.

Step 1: Watch the water heater's display screen for the Remote Access icon to appear (Figure 5). This may take a minute after the power has been turned on.

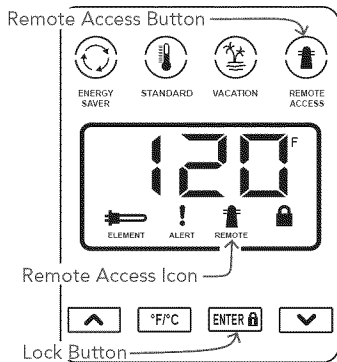

Step 2: Activate the screen by touching any button, then releasing it.

Step 3: If the screen is locked, touch and hold the Lock button for at least 5 seconds (Figure 5).

Step 4: Touch the Remote Access button (Figure 5, top right). The Remote Access button must be backlit before continuing with setup.

Step 5:
Go to Section 6 and download the app.

Figure 5:
Water Heater Control Panel

5

Enable the Water Heater

(Cont'd)

Follow these steps if you have a heat pump water heater. Otherwise, go to Section 6.

- Step 1:** After turning power on, wait for the diagnostics to run. It will take up to eight minutes for the water heater to complete its diagnostics. The controller will initialize when the diagnostics are finished.

The screen will display the following:

1. r.A (3 seconds; this means Remote Access not enabled; local control only).
2. 120F (3 seconds; indicates temp. set point).

Figure Figure 6: Heat Pump User Interface and Controller

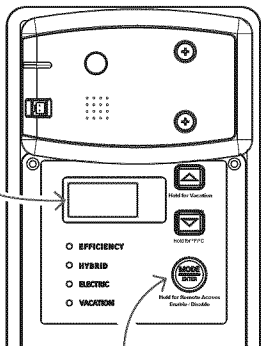



- Step 2:** Press the Mode button for five seconds.

5

Enable the Water Heater (Cont'd)

Step 2 continued...

The screen will display the following:

1.  (1 second)
2.  (1 second)
3.  (1 second)
4. **120^F** (3 seconds; indicates temperature set point)

When this process is complete, remote access is enabled. The water heater can be controlled both locally and remotely.

Step 3: Go to Section 6 and download the app.



Link

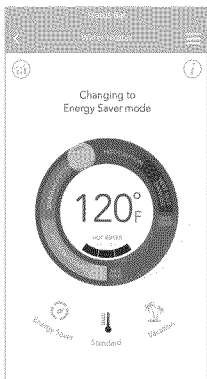

Download the Kenmore® Smart app



1. Launch the Kenmore® Smart app on your smartphone, then follow the simple steps.
2. The Kenmore® Smart app makes it easy to set up, program and control your Kenmore® Smart Water Heater Module and other Kenmore® Smart products.

Apple, the Apple logo and iPhone are trademarks of Apple Inc., registered in the U.S. and other countries. App Store is a service mark of Apple, Inc. Google Play and Android are trademarks of Google Inc.

Customer Care

If you need help connecting your
Kenmore® Smart Water Heater Module,

call

1-844-553-6667

or visit

www.kenmore.com/smart

Kenmore Limited Warranty

FOR ONE YEAR from the date of sale this product is warranted against defects in material or workmanship when it is correctly connected, operated and maintained according to all supplied instructions.

WITH PROOF OF SALE, return a defective product to the retailer from which it was purchased for free replacement.

This warranty does not cover the batteries, which are expendable parts that can wear out from normal use within the warranty period.

This warranty is void if this product is ever used for other than private household purposes.

This warranty covers ONLY defects in material and workmanship, and will NOT pay for:

1. Damage to or failure of this product if it is not correctly connected, operated or maintained according to all supplied instructions.
2. Damage to or failure of this product resulting from accident, alteration, abuse, misuse or use for other than its intended purpose.
3. Damage to or failure of parts or systems resulting from unauthorized modifications made to this product.

Disclaimer of implied warranties; limitation of remedies

Customer's sole and exclusive remedy under this limited warranty is product replacement as provided herein. Implied warranties, including warranties of merchantability or fitness for a particular purpose, are limited to one year or the shortest period allowed by law. Seller shall not be liable for incidental or consequential damages. Some states and provinces do not allow the exclusion or limitation of incidental or consequential damages, or limitation on the duration of implied warranties of merchantability or fitness, so these exclusions or limitations may not apply to you.

This warranty gives you specific legal rights, and you may also have other rights which vary from state to state.

Sears Brands Management Corporation, Hoffman Estates, IL 60179

Regulatory Notices

FCC (UNITED STATES):

This device complies with Part 15 of the FCC Rules. Operation is subject to the following two conditions: (1) This device may not cause harmful interference, (2) This device must accept any interference received including interference that may cause undesired operation.

Note: This equipment has been tested and found to comply with the limits for a Class B digital device, pursuant to part 15 of the FCC rules. These limits are designed to provide reasonable protection against interference in a residential installation. This equipment generates, uses, and can radiate radio frequency energy and, if not installed and used in accordance with the instruction manual, may cause interference to radio communications. However, there is no guarantee that interference will not occur in a particular installation. If this equipment does cause interference to radio or television reception, which can be determined by turning the equipment off and on, the user is encouraged to try to correct the interference by one or more of the following measures:

- Reorient or relocate the receiving antenna.
- Increase the separation between the equipment and receiver.
- Connect the equipment into an outlet on a circuit different from that to which the receiver is connected.
- Consult the dealer or an experienced radio/TV technician.

CAUTION: Changes or modifications to this equipment not expressly approved by the party responsible for compliance (A.O. Smith Corporation) could void the user's authority to operate the equipment.

ICES-003 (CANADA):

This Class B digital apparatus complies with Canadian ICES-003.

Cet appareil numérique de la classe B est conforme à la norme NMB-003 du Canada.

DATA NOTICE:

Data relating to your water heater may be periodically uploaded from this device. A. O. Smith is the owner of all such data and will use the data for business purposes including but not limited to product improvement.

Notes

Notes

*this is
the beginning
of a beautiful
friendship*



www.kenmore.com | www.kenmore.com/smart

Copyright © Sears Brands Management Corporation.
All Rights Reserved.

100262942