

# INSTALLATION INSTRUCTIONS

## Fan Coils

### FEM4X, FSM4X, FSU4X, FXM4X

These instructions must be read and understood completely before attempting installation.

#### Safety Labeling and Signal Words

##### DANGER, WARNING, CAUTION, and NOTE

The signal words **DANGER**, **WARNING**, **CAUTION**, and **NOTE** are used to identify levels of hazard seriousness. The signal word **DANGER** is only used on product labels to signify an immediate hazard. The signal words **WARNING**, **CAUTION**, and **NOTE** will be used on product labels and throughout this manual and other manuals that may apply to the product.

**DANGER** - Immediate hazards which **will** result in severe personal injury or death.

**WARNING** - Hazards or unsafe practices which **could** result in severe personal injury or death.

**CAUTION** - Hazards or unsafe practices which **may** result in minor personal injury or product or property damage.

**NOTE** - Used to highlight suggestions which **will** result in enhanced installation, reliability, or operation.

##### Signal Words in Manuals

The signal word **WARNING** is used throughout this manual in the following manner:



The signal word **CAUTION** is used throughout this manual in the following manner:



##### Signal Words on Product Labeling

Signal words are used in combination with colors and/or pictures on product labels.

#### TABLE OF CONTENTS

Introduction .....	1
Location .....	2
Clearances .....	2
Heater Packages .....	2
Position Unit .....	2
Air Ducts .....	7
Electrical Connections .....	7
Refrigerant Tubing .....	11
Refrigerant Metering Device .....	11
Condensate Drains .....	11
Accessories .....	12
Sequence of Operation .....	12
Start-up Procedure .....	13
Care and Maintenance .....	13
Airflow Performance .....	15
R-410A Quick Reference Guide .....	18

**PERSONAL INJURY, AND/OR PROPERTY DAMAGE HAZARD**

**Failure to carefully read and follow this warning could result in equipment malfunction, property damage, personal injury and/or death.**

**Installation or repairs made by unqualified persons could result in equipment malfunction, property damage, personal injury and/or death.**

**The information contained in this manual is intended for use by a qualified service technician familiar with safety procedures and equipped with the proper tools and test instruments.**

**Installation must conform with local building codes and with the National Electrical Code NFPA70 current edition.**

#### INTRODUCTION

Models FEM4X, FSM4X, and FXM4X are designed for maximum flexibility and can be used for upflow, horizontal left or right, and downflow applications (accessory kit required for downflow or horizontal right).

Model FSU4X is designed for upflow installation, and can be field modified for downflow and horizontal left or right applications (accessory kits required for downflow or horizontal).

FEM4X and FXM4X models are available for system sizes 1-1/2 - 5 tons (18,000 - 60,000 BTUH) nominal cooling capacity.

FSM4X, and FSU4X models are available for system size 5 ton (60,000 BTUH) nominal cooling capacity.

FEM4X and FXM4X models use an ECM motor and have a factory installed and appropriately sized hard shut-off TXV metering device and are for R-410A refrigerant ONLY.

FSM4X and FSU4X models use a PSC motor and have a factory installed and appropriately sized hard shut-off TXV metering device and are for R-410A refrigerant ONLY.

Factory approved electric heater packages are available in sizes 3kW through 30kW. See Product Specification literature for available accessory kits.

**LOCATION**

Select the best position which suits the installation site conditions. The location should provide adequate structural support, space in the front of the unit for service access, clearance for return air and supply duct connections, space for refrigerant piping connections and condensate drain line connections. If heaters are being installed make sure adequate clearance is maintained from supply duct work.

Nuisance sweating may occur if the unit is installed in a high humidity environment with low airflow. On these installations a wrap of 2" (51mm) fiberglass insulation with a vapor barrier is recommended.

REQUIRED CLEARANCES - ALL MODELS (inches)		
No Heaters	All Sides	0
Heaters	From Supply Duct	0
With Heaters	All Sides	0
	From First 3 feet of Supply Duct to Combustibles	1
	From Supply Duct to Combustibles after 3 feet	0

**NOTE:** Internal filter can be accessed from separate filter door. If the filter can **NOT** be easily accessed, a remote filter is recommended. Refer to ACCA Manual D for remote filter sizing.

**⚠ WARNING**

**FIRE HAZARD**

Failure to maintain proper clearances could result in personal injury, death, and/or property damage.

When heaters are installed, maintain clearances from combustible materials as specified on unit rating plate. Do not use plastic lined or combustible flexible ducting within 36 inches (1m) of the supply end of the fan coil.

**HEATER PACKAGES**

Factory approved, field installed, UL listed heater packages are available from the equipment supplier. See unit rating plate for a list of factory approved heaters. Heaters that are not factory approved could cause damage which would not be covered under the equipment warranty.

**POSITION UNIT**

Unit can stand or lie on floor, or hang from ceiling or wall. Allow space for wiring, piping, and servicing unit.

**⚠ CAUTION**

**PROPERTY DAMAGE HAZARD**

Failure to follow this caution may result in property damage

A field fabricated auxiliary drain pan, with a separate drain is **REQUIRED** for all installations over a finished living space or in any area that may be damaged by overflow from a restricted main drain pan. In some localities, local codes require an auxiliary drain pan for ANY horizontal installation.

**A. UPFLOW INSTALLATION**

If return air is to be ducted through a floor, set unit on floor over opening and use 1/8 to 1/4 inch thick (3 to 6 mm thick) fireproof resilient gasket between duct, unit, and floor.

Side return is a field option on slope coil models. Cut opening per dimensions shown in Figure 2. A field-supplied bottom closure is required.

**B. MODULAR UNITS**

The FSU4X6000, FXM4X4800/6000, FEM4X4800/6000, and FSM4X4800/6000 fan coils are two-piece modular units. This allows for modular units to be disassembled and components moved separately to installation area for reassembly. This process accommodates small scuttle holes and limiting entrances to installation sites (refer to **Figure 1**).

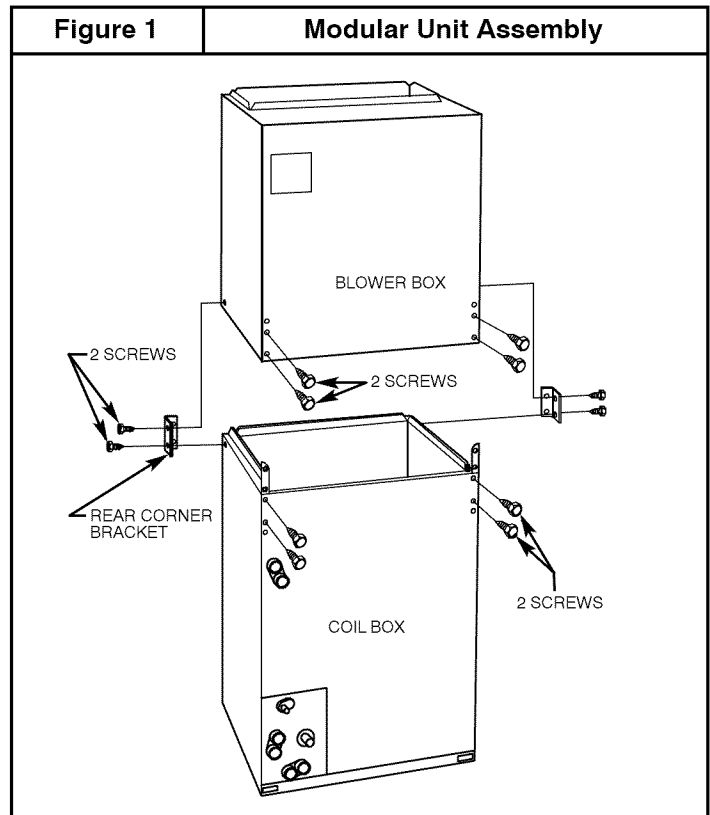

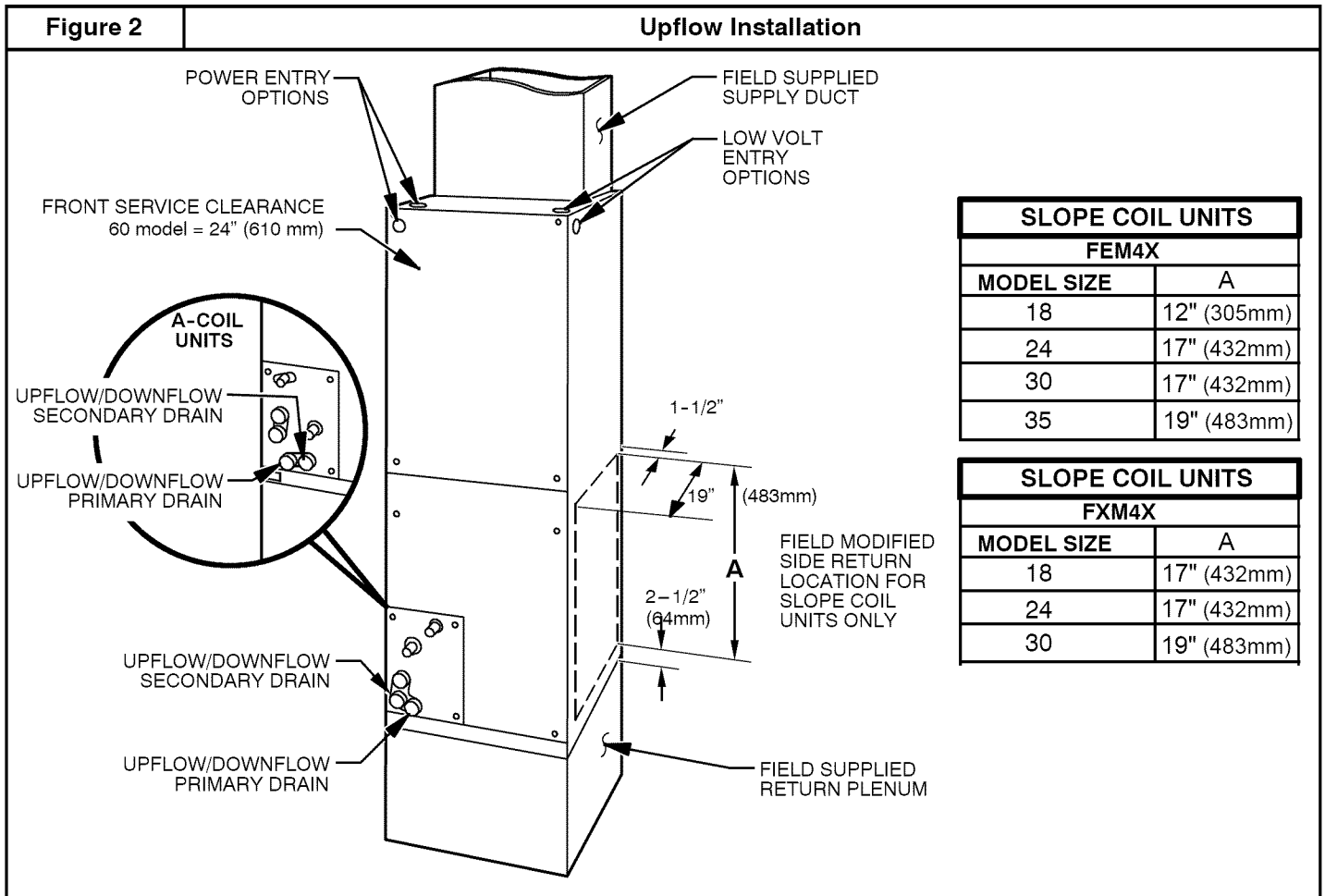

**B. DOWNFLOW INSTALLATION**

**⚠ CAUTION**

**PRODUCT OR PROPERTY DAMAGE HAZARD**

Failure to follow this caution may result in product or property damage

The conversion of the fan coil to downflow requires special procedures for the condensate drains on both A-coil and Slope-coil units. The vertical drains have an overflow hole between the primary and secondary drain holes. This hole is plugged for all applications except downflow, and must be used for downflow. Failure to follow instructions could result in personal injury or product and property damage.

In this application, field conversion of the evaporator coil is required using accessory Downflow Kit along with an accessory Base Kit. Set unit on floor over opening and use 1/8" to 1/4" thick fireproof resilient gasket between duct, unit, and floor. Refer to installation instructions packaged with accessory kit. See Product Specification literature for kit part numbers.

During the conversion process, removed the plastic cap covering the vertical drains only and discard.

Remove the plug from the overflow hole and discard.

At completion of the downflow installation, caulk around the vertical pan fitting to door joint to retain low air leak performance of the unit.

**NOTE:** Gasket kit number (EBAC01GSK) is also required for all downflow applications to maintain low air leak/low sweat performance.

**C. HORIZONTAL INSTALLATION**

Unit must NOT be installed with access panels facing up or down. Access panels must only face to the side.

FEM4X, FSM4X, and FXM4X models are factory built for horizontal left installation (refer to Figure 3 and Figure 4). They can be field converted to horizontal right (accessory Gasket Kit required, see Product Specification literature for part number). Refer to Figure 5 and Figure 6.

FSU4X models require accessory kits for any horizontal installation (see Product Specification literature for required accessory kits).

**NOTE:** When suspending unit from ceiling, dimples in casing indicate suitable location of screws for mounting metal support straps.

**NOTE:** For optimum condensate drainage performance in horizontal installations, unit should be leveled along its length and width.

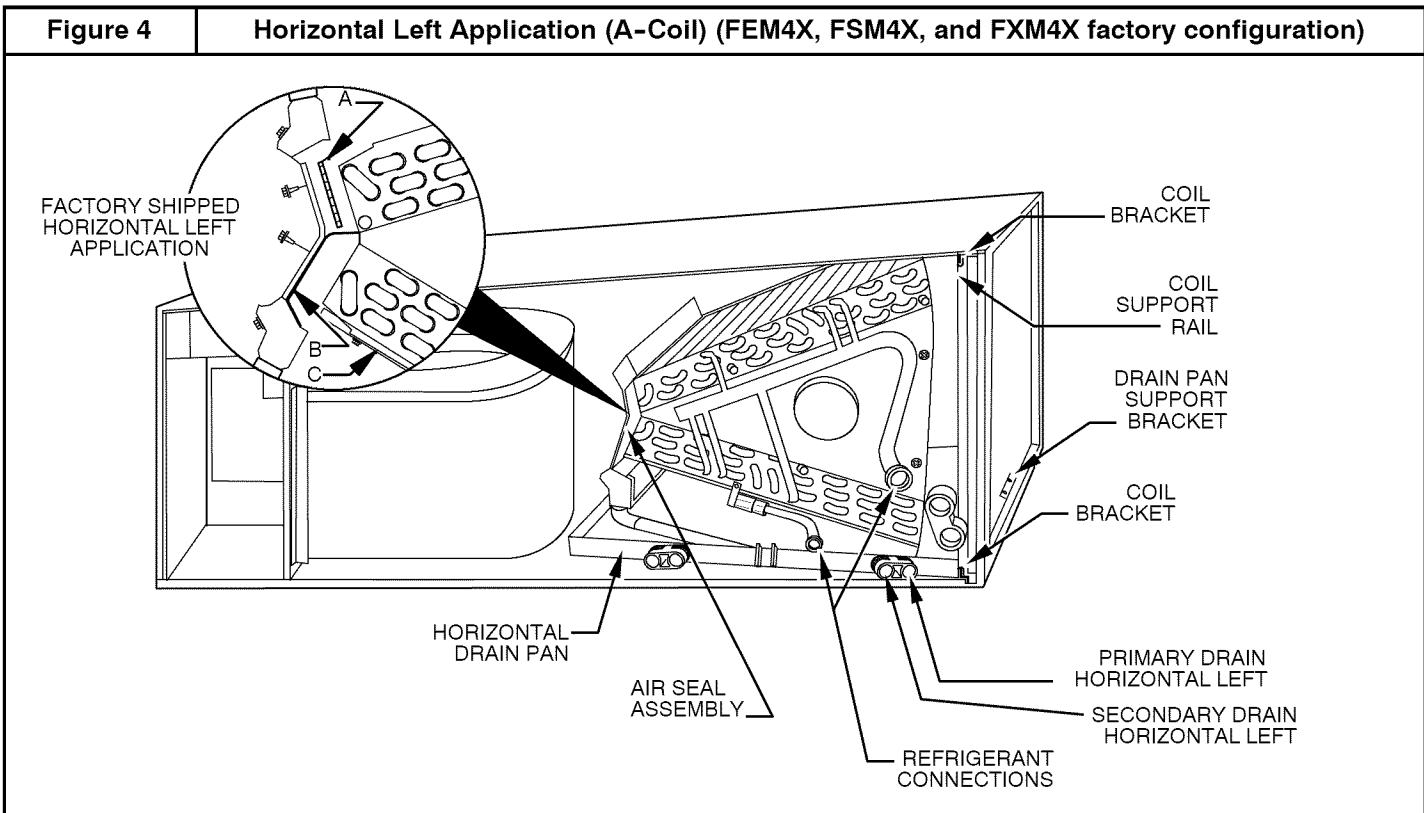
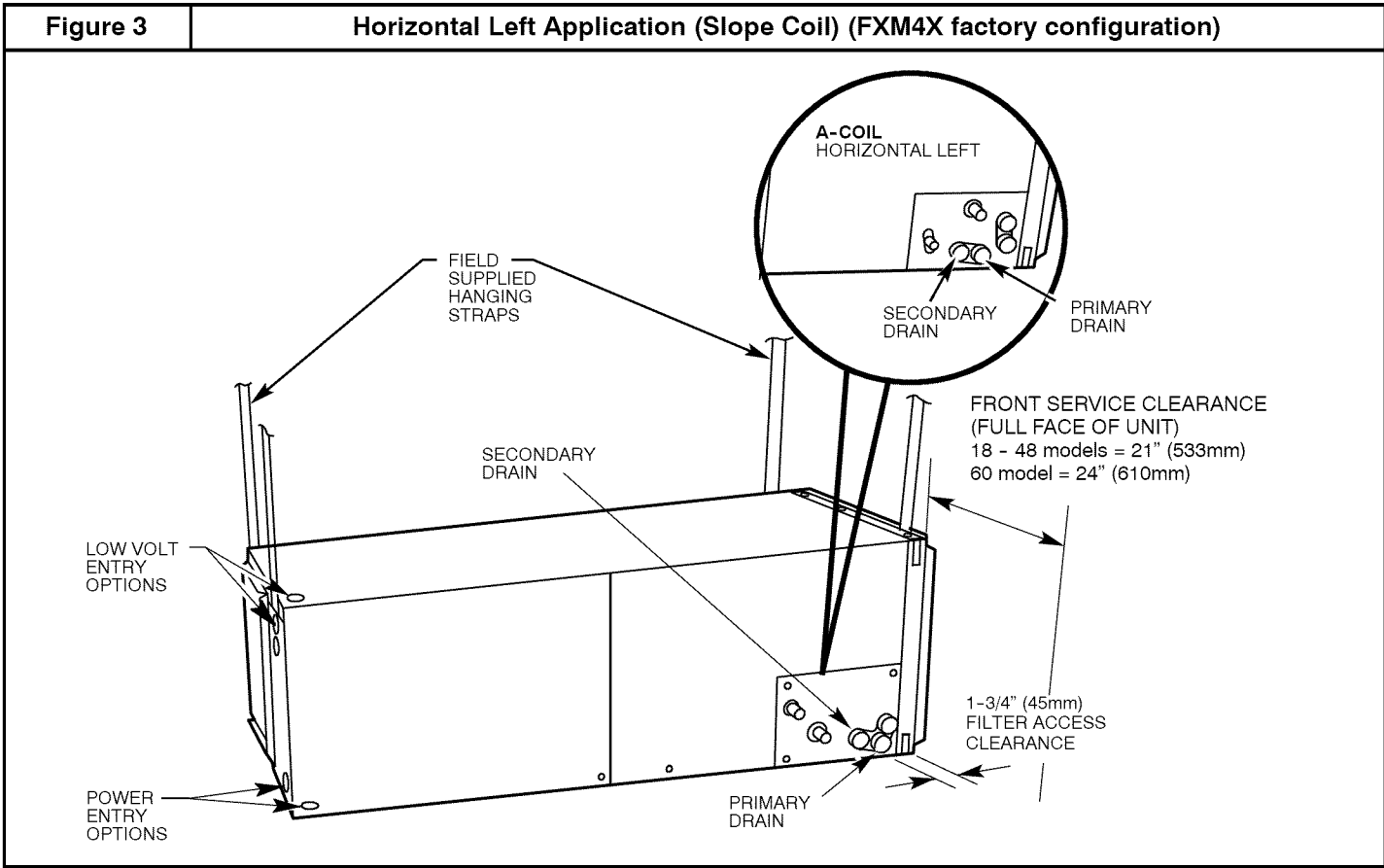

**Horizontal Right Conversion of Units With Slope Coils**

1. Remove blower and coil access panel and fitting panel (refer to Figure 5).
2. Remove coil mounting screw securing coil assembly to right side casing flange.
3. Remove coil assembly.
4. Lay fan coil unit on its right side and reinstall coil assembly with condensate pan down (refer to Figure 5).
5. Attach coil to casing flange using coil mounting screw previously removed.
6. Align holes with tubing connections and condensate pan connections, and reinstall access panels and fitting panel. After brazing, make sure liquid and suction tube grommets are in place to prevent air leaks and cabinet sweating.

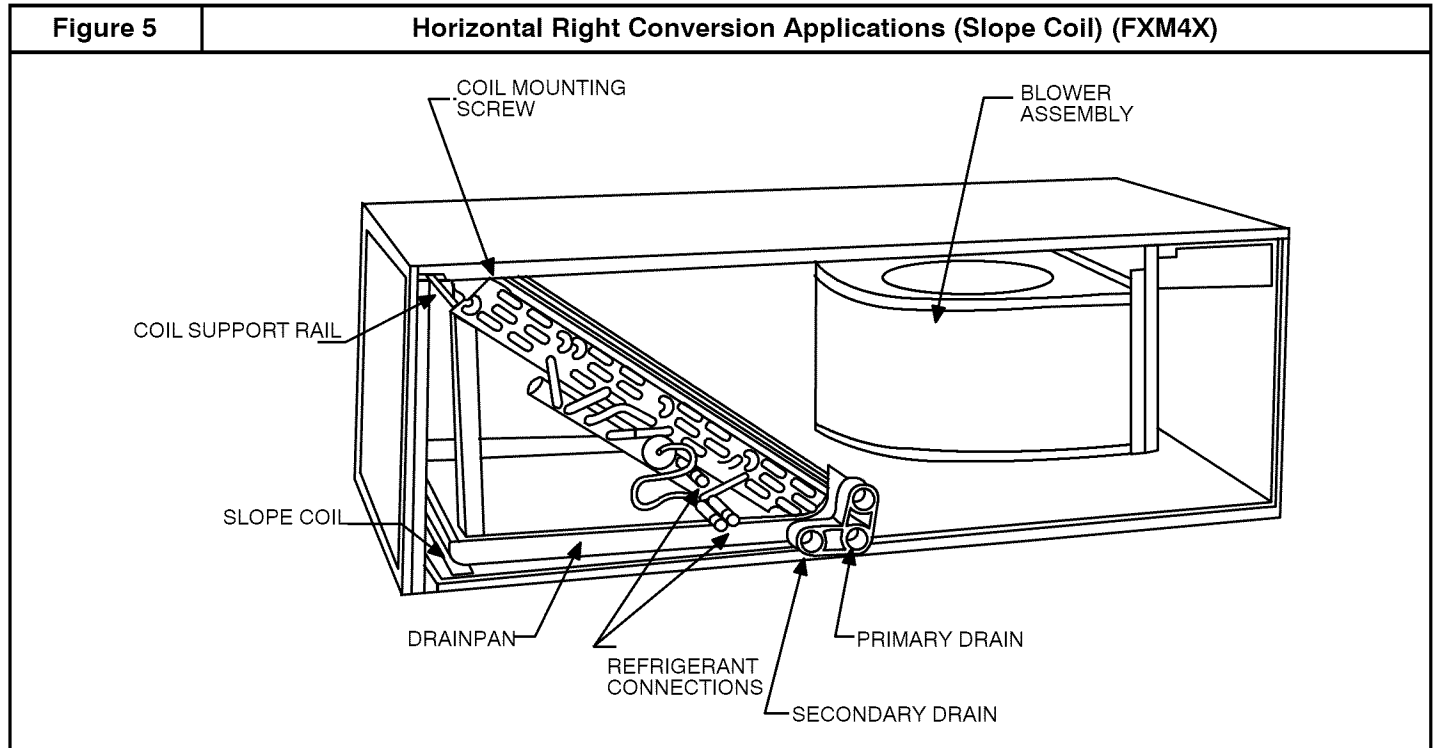

**Horizontal Right Conversion of Units With A-Coils**

1. Remove blower and coil access panel and fitting panel (refer to Figure 6).
2. Remove coil mounting screw securing coil assembly to right side casing flange.
3. Remove coil assembly.
4. Lay fan coil unit on its right side and reinstall coil assembly with condensate pan down (refer to Figure 6).
5. Remove horizontal drain pan support bracket from coil support rail on left side of unit and reinstall on coil support rail on right side of unit.
6. Convert air-seal assembly for horizontal right (refer to Figure 6).
  - a. Remove air-seal assembly from coil by removing 4 screws.
  - b. Remove coil drip flanges from A-coil and reinstall on right side of coil (same side as horizontal drain pan).
  - c. Remove filler plate (A) and install air splitter (B) in place of filler plate.
  - d. Install filler plate (A) as shown in horizontal right application.
  - e. Remove condensate troughs (C) and install on opposite tube sheets.
  - f. Install hose onto plastic spout.
7. Install horizontal pan on right side of coil assembly.
8. Slide coil assembly into casing. Be sure coil bracket on each corner of vertical pan engages coil support rails.
9. Reinstall 2 snap-in clips to correctly position and secure coil assembly in unit. Be sure clip with large offsets is used on right side of unit to secure horizontal pan.
10. Remove 2 oval coil access panel plugs and reinstall into holes on left side of coil access panel and fitting panel.
11. Remove insulation knockouts on right side of coil access panel
12. Reinstall access fitting panels, aligning holes with tubing connections and condensate pan connections. Be sure to reinstall metal clip between fitting panel and vertical condensate pan.
13. After brazing, make sure liquid and suction tube grommets are in place to prevent air leaks and cabinet sweating.

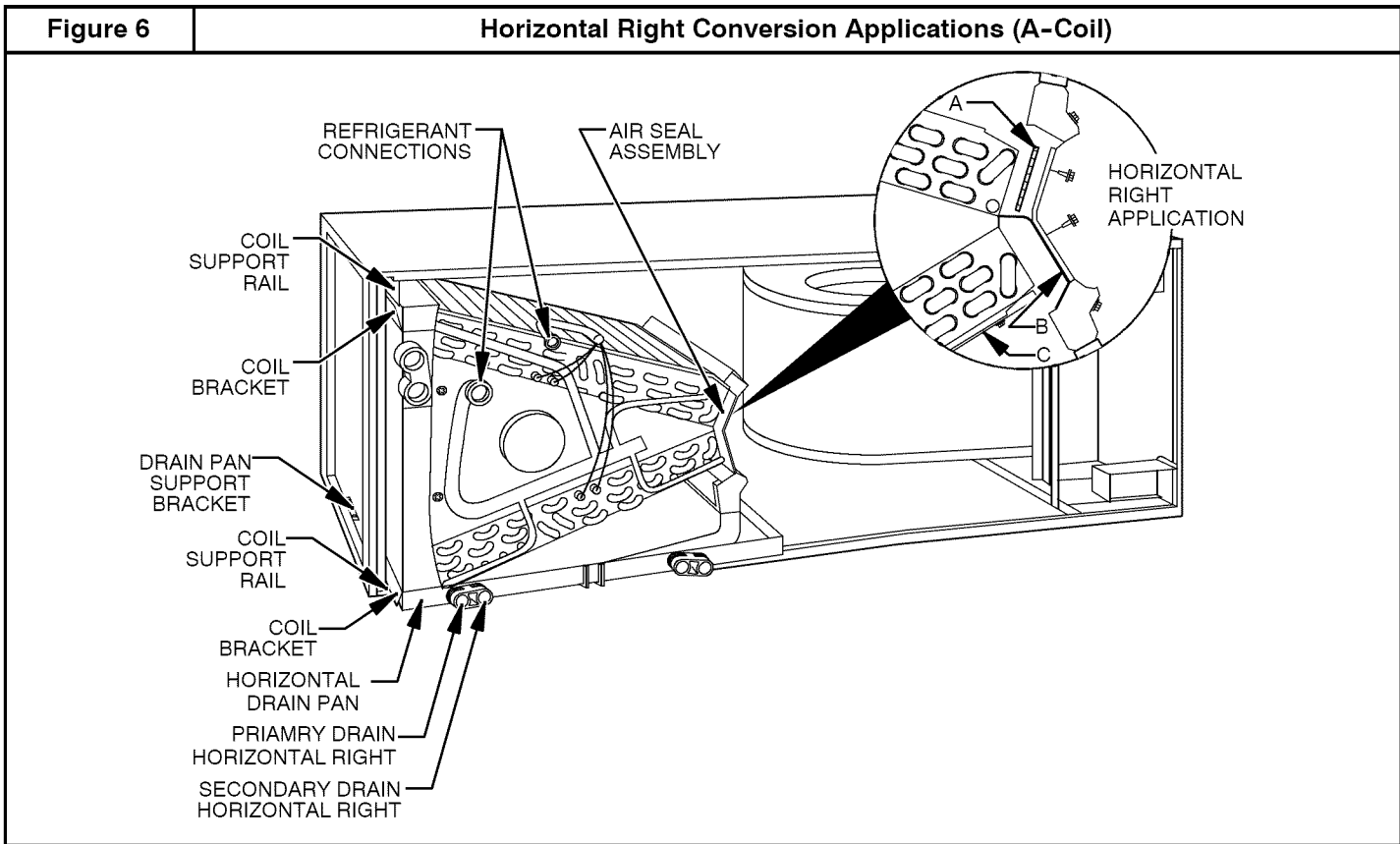

**D. MANUFACTURED HOUSING AND MOBILE HOME APPLICATIONS**

1. Fan coil unit must be secured to the structure using field-supplied hardware.
2. Allow a minimum of 24 inches (610mm) clearance from access panels.
3. Recommended method of securing for typical applications:
  - a. If fan coil is away from wall, attach pipe strap to top of fan coil using No. 10 self tapping screws. Angle strap down and away from back of fan coil, remove all slack, and fasten to wall stud of structure using 5/16" lag screws. Typical both sides of fan coil.
  - b. If fan coil is against wall, secure fan coil to wall stud using 1/8" (3mm) wide right-angle brackets. Attach brackets to fan coil using No. 10 self tapping screws and to wall stud using 5/16" lag screws (refer to Figure 7).

**NOTE:** Modular units can be disassembled and components moved separately to installation area for reassembly. This process accommodates small scuttle holes and limiting entrances to installation sites (refer to Figure 8).

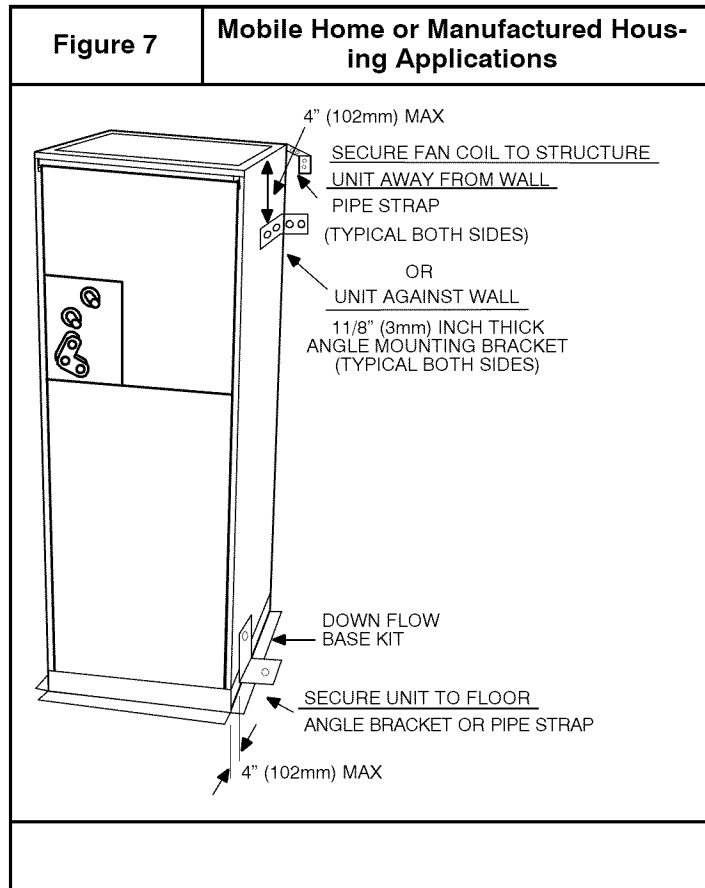

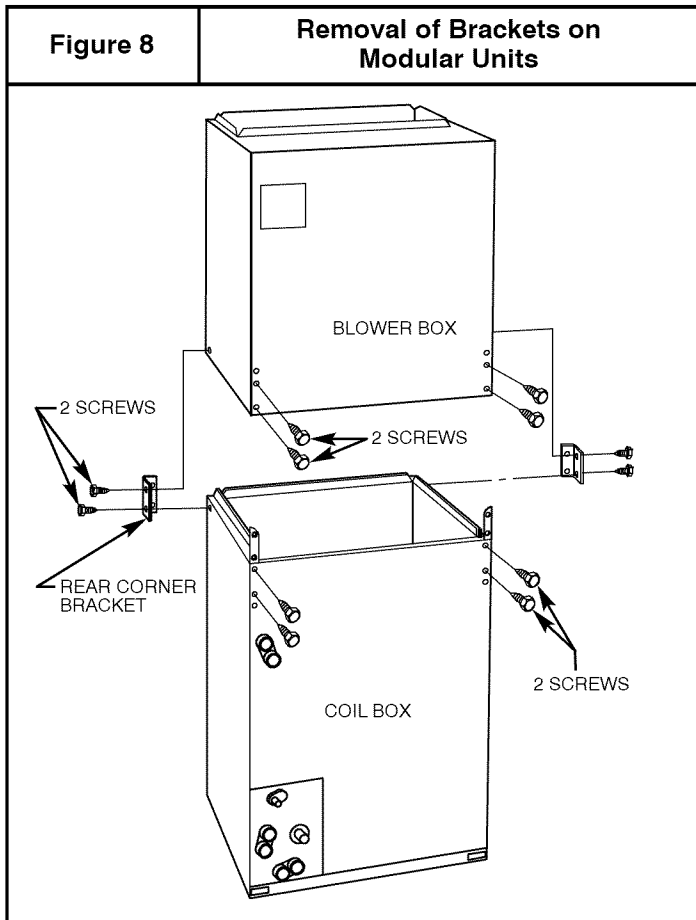

## ELECTRICAL CONNECTIONS

FEM4X (1-1/2 to 4 ton), FSM4X and FSU4X Fan Coil models utilize an electronic fan board which has a low voltage circuit protective fuse (5 amp), fan motor speed tap terminal (SPT), and time-delay relay (TDR). To disable the TDR feature, snip the jumper wire JW1 (refer to Figure 9).

FEM4X (5 ton) and FXM4X Fan Coil models have a low voltage circuit protective fuse (3 amp) inline on the wire harness. Speed selections are made at the fan motor by selecting taps 1, 2, or 3 with the Blue wire. The motor is pre-programmed with the time-delay circuit on some of the speed taps. (See Section D)

Before proceeding with electrical connections, make certain that supply voltage, frequency, phase, and circuit ampacity are as specified on the unit rating plate. See unit wiring label for proper field high and low voltage wiring.

**⚠ WARNING**

**ELECTRICAL SHOCK or UNIT DAMAGE HAZARD**

**Failure to follow this warning could result in personal injury, death, and/or unit damage.**

**If a disconnect switch is to be mounted on unit, select a location where drill and fasteners will not contact electrical or refrigeration components.**

Make all electrical connections in accordance with the NEC and any local codes or ordinances that may apply. Use copper wire only. The unit must have a separate branch electric circuit with a field-supplied disconnect switch located within sight from and readily accessible from the unit.

**NOTE:** When a pull-out type disconnect is removed from the unit, only the Load side of the circuit is de-energized. The Line side remains live until the main (remote) disconnect is turned off.

**⚠ WARNING**

**ELECTRICAL SHOCK HAZARD**

**Failure to follow this warning could result in personal injury or death.**

**Turn off the main (remote) disconnect device before working on incoming (field) wiring . Incoming (field) wires on the line side of the disconnect found in the fan coil unit remain live, even when the pull-out is removed. Service and maintenance to incoming (field) wiring cannot be performed until the main disconnect switch (remote to the unit) is turned off.**

## AIR DUCTS

Connect supply-air duct over the outside of 3/4" flanges provided on supply-air opening. Secure duct to flange using proper fasteners for type of duct used, and seal duct-to-unit joint.

It is a recommendation, but not a requirement, to use flexible connections between ductwork and unit to prevent transmission of vibration. When electric heater is installed, use heat-resistant material for flexible connector between duct work and unit at discharge connection. Duct work passing through unconditioned space must be insulated and covered with vapor barrier.

### Duct work Acoustical Treatment

Metal duct systems that do not have a 90 degree elbow and 10 feet of main duct before first branch takeoff may require internal acoustical insulation lining. As an alternative, fibrous duct work may be used if constructed and installed in accordance with the latest edition of SMACNA construction standard on fibrous glass ducts. Both acoustical lining and fibrous duct work shall comply with National Fire Protection Association as tested by UL Standard 181 for Class 1 air ducts.

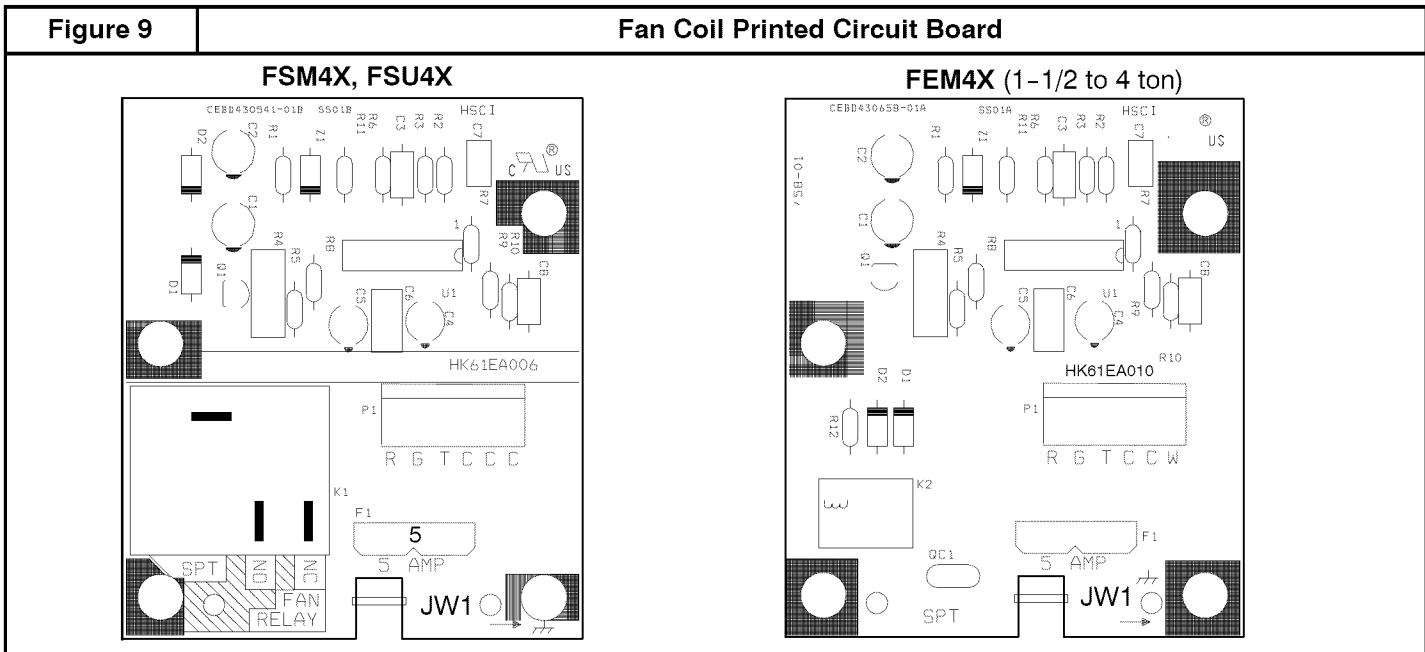

**A. LINE VOLTAGE CONNECTIONS**

Fan Coils installed without electric heat require the use of a factory-authorized Power Plug Kit (accessory part number EBAC01PLG). This kit provides the electrical connections necessary to supply the unit with 208/230V power when electric heat is not present. For units without electric heat:

1. Connect 208/230V power leads from field disconnect to yellow and black stripped leads on Power Plug (accessory part number EBAC01PLG).
2. Connect ground wire to unit ground lug.
3. When installing an electric heater, remove and discard power plug (if equipped) from fan coil and connect male plug from heater to female plug from unit wiring harness. (See Electric Heater Installation Instructions.)

**B. 24V CONTROL SYSTEM**

**Connection to Unit**

Wire low voltage in accordance with wiring label on the blower (also refer to Figure 10 through Figure 14). Use 18 AWG color-coded, insulated (35° C minimum) wire to make the low-voltage connections between the thermostat, the unit, and the outdoor equipment. If the thermostat is located more than 100 feet from the unit (as measured along the low voltage wire), use 16 AWG color-coded, insulated (35° C minimum) wire. All wiring must be NEC Class 1 and must be separated from incoming power leads. Refer to outdoor unit wiring instructions for additional wiring recommendations.

**Heater Staging**

The controls are factory circuited for single-stage operation (refer to Figure 11 and Figure 12). When 2 stages are desired, cut W3 at the W2 wire nut, strip, and reconnect according to the thermostat kit instruction (refer to Figure 13 - outdoor thermostat optional). When 3 stages are desired, cut the W2 wire nut off and discard. Strip W2, W3, and E, and

reconnect according to the thermostat kit instructions (refer to Figure 14 outdoor thermostats optional).

⚠ CAUTION

UNIT OPERATION HAZARD

Failure to follow this caution may result in improper product operation.

If W2, W3, and E on any 3 stage heater (18, 20, 24, or 30kW) are individually connected - as with outdoor thermostats or any other situation - emergency heat relay must be used. If relay is not used, blower may not operate when heaters are energized.

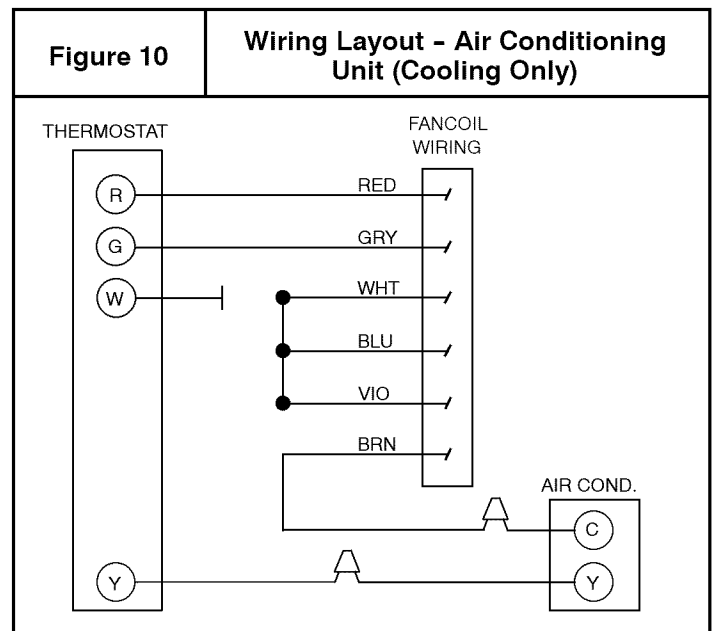



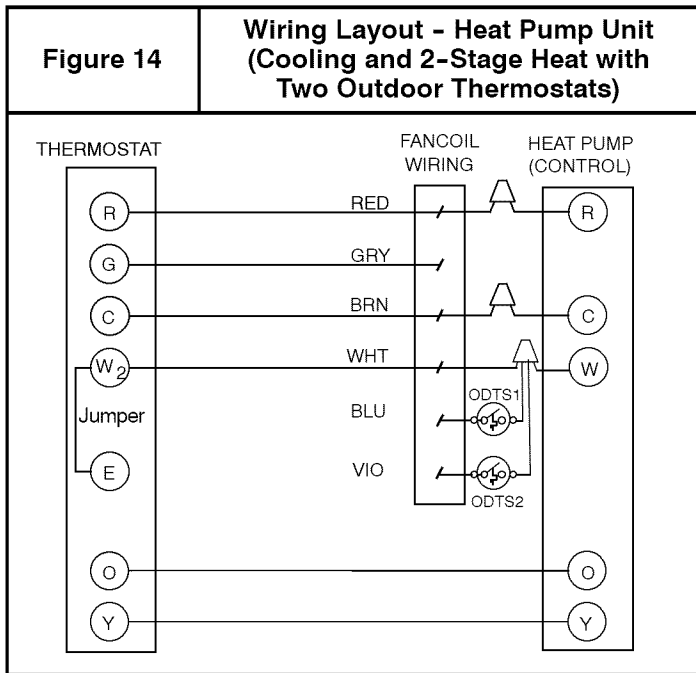
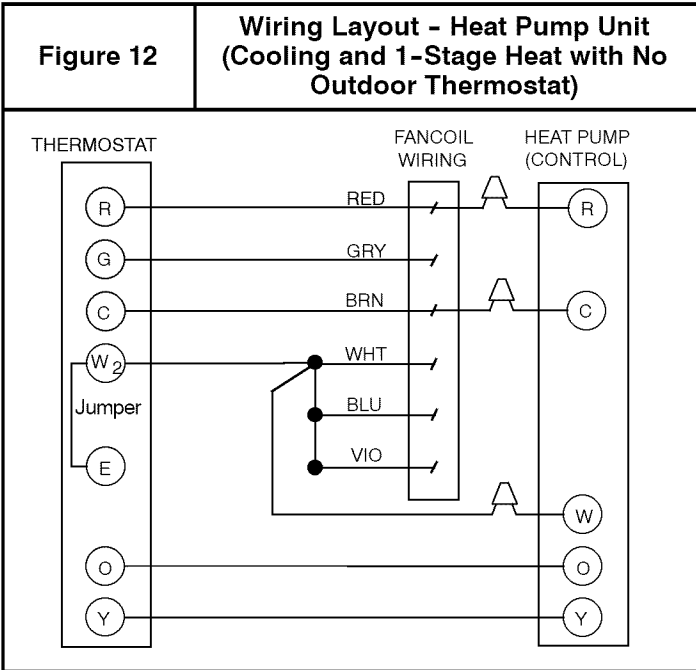
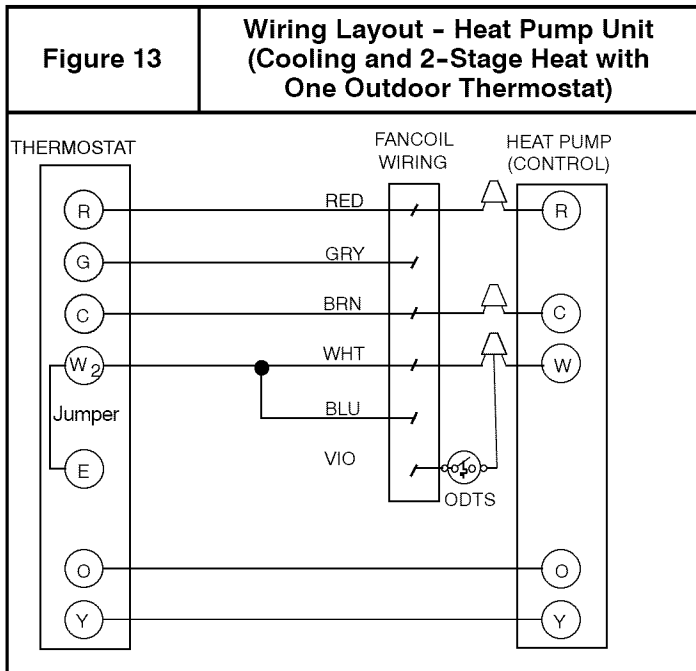
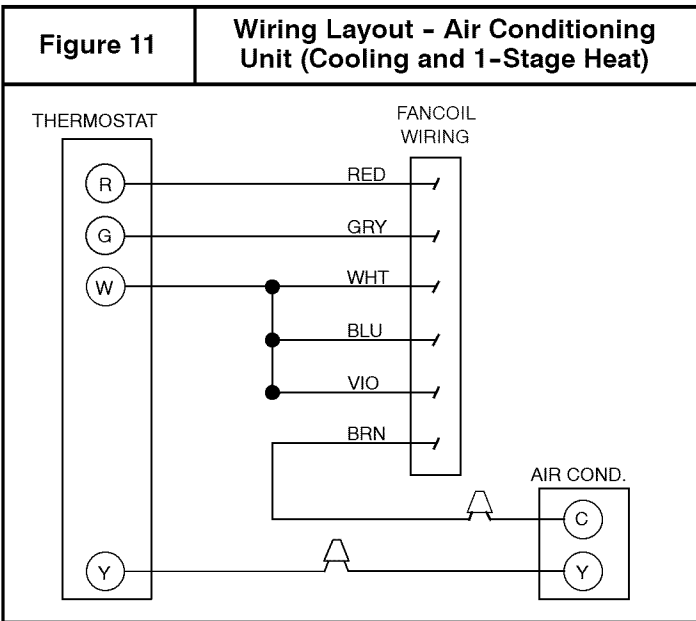

**Transformer Information**

Transformer is factory wired for 230V operation. For 208V applications, disconnect the black wire from the 230V terminal on transformer and connect it to the 208V terminal (refer to Figure 15).

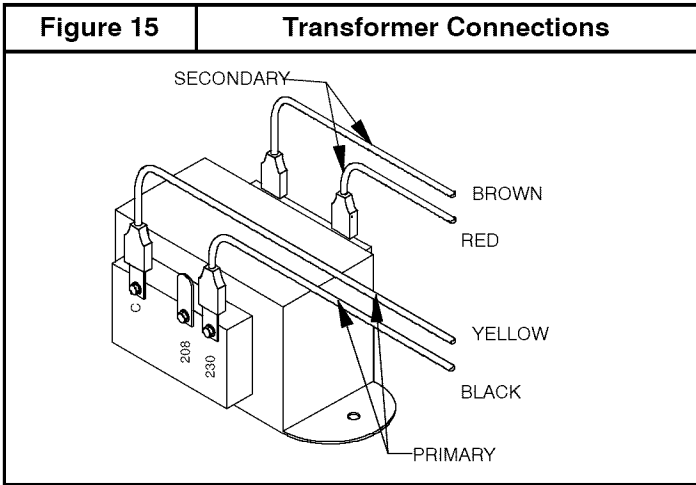

**SPEED TAP SELECTION AT MOTOR CONNECTOR**

Tap	Speed	Off Delay
Tap 1	Low	90 sec off delay
Tap 2	Medium	90 sec off delay
Tap 3	High	90 sec off delay
Tap 4	Electric Heat †	0 sec off delay
Tap 5	Max ‡	0 sec off delay

† Electric heat airflow is same CFM as Tap 3, but with 0 sec off delay.

‡ For high static applications, see Airflow Performance Tables for max airflow.

To change motor speeds disconnect the BLUE fan lead from motor connector terminal #2 (factory default position) and move to desired speed-tap; 1, 2, 3, or 5.

Speed-taps 1, 2, and 3 have a 90 second blower off time delay pre-programmed into the motor. Speed tap 4 is used for electric heat only (with 0 second blower time delay) and the WHITE wire should remain on tap 4. Speed-tap 5 is used for high static applications, but has a 0 second blower time delay pre-programmed into the motor (see Airflow Performance Tables for actual CFM for each tap). Also, see Figure 16 for motor speed selection location.

**NOTE:** In low static applications, lower motor speed tap should be used to reduce possibility of water being blown off coil.

**C. GROUND CONNECTIONS**

**⚠ WARNING**

**ELECTRICAL SHOCK HAZARD**

Failure to establish uninterrupted or unbroken ground could result in personal injury and/or death.

According to NEC, ANSI/NFPA 70, and local codes, the cabinet must have an uninterrupted or unbroken ground in order to minimize potential for personal injury or death if an electrical fault should occur. The ground may consist of electrical wire or metal conduit when installed in accordance with existing electrical codes. If conduit connection uses reducing washers, a separate ground wire must be used.

**NOTE:** Use UL listed conduit and conduit connectors for connecting supply wire(s) to unit to obtain proper grounding. Grounding may also be accomplished by using grounding lugs provided in control box.

**D. MINIMUM CFM AND MOTOR SPEED SELECTION**

Units with or without electric heaters require a minimum CFM. Refer to the unit wiring label to ensure that the fan speed selected is not lower than the minimum fan speed indicated.

**FEM4X models** (1-1/2 to 4 ton): fan speed selection is done at the fan motor. To change motor speeds, reposition wire at fan motor speed terminals labeled 1-2-3 (refer to Figure 16).

**FSM4X and FSU4X models:** fan speed selection is done at the fan relay on the electronic fan board. To change motor speeds, disconnect fan lead used on relay terminal (SPT) and replace with motor speed lead desired (refer to Figure 17). Save insulating cap and place on motor lead removed from relay.

**NOTE:** In low static applications, lower motor speed tap should be used to reduce possibility of water being blown off coil.

All units have 2 or 3 motor speed taps. Low speed (red or 1) is designed for mismatch outdoor unit applications. Medium speed (blue or 2) is designed for straight matched operations. High speed (black or 3) is used with high external static duct situations on straight matched systems.

**FEM4X (5 ton) and FXM4X models:** fan speed is selected at the motor connector. Units with or without electric heaters require a minimum CFM. Refer to the unit wiring label to ensure that the fan speed selected is not lower than the minimum fan speed indicated.

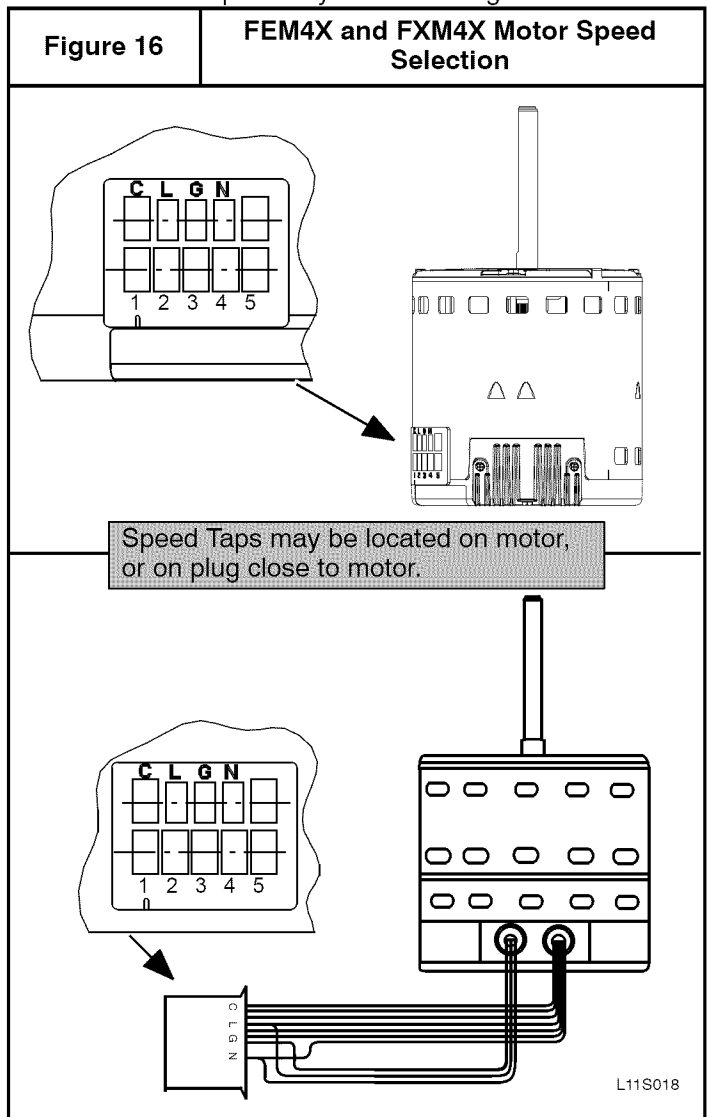

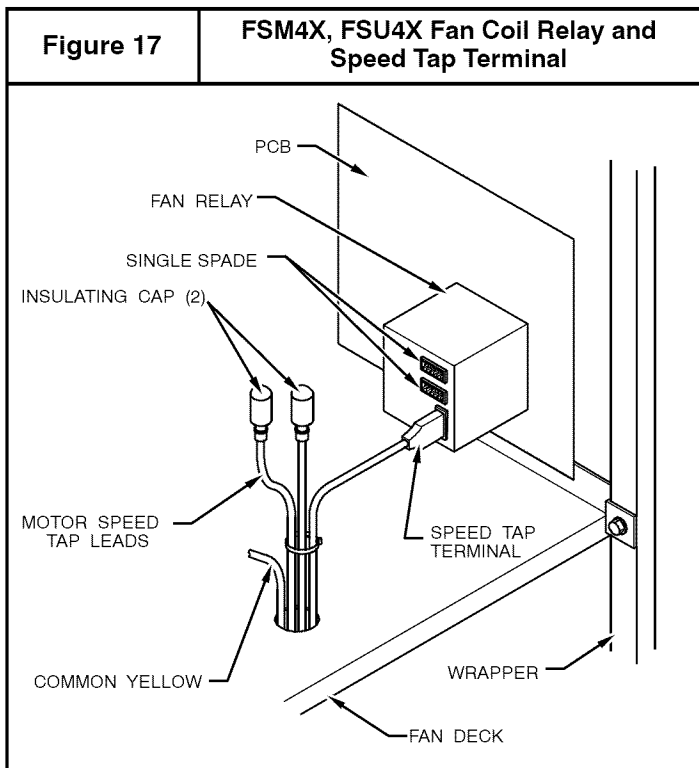

## REFRIGERANT METERING DEVICE

### FEM4X, FSM4X, FSU4X, FXM4X

These Fan Coils have a factory installed hard shut-off TXV designed only for use with R-410A refrigerant. Use only with outdoor units designed for R-410A.

TXV is factory set and not field adjustable.

**⚠ CAUTION**

**PRODUCT DAMAGE HAZARD**

Failure to follow this caution may result in product damage.

**This Fan Coil has a hard shut-off TXV metering device. A compressor Hard Start Kit is REQUIRED in all applications where the matching outdoor unit has a single-phase reciprocating compressor.**

## REFRIGERANT TUBING

Size and install refrigerant lines according to information provided with outdoor unit. Route refrigerant lines to the fan coil in a manner that will not obstruct service access to the unit or removal of the filter.

1. Find the liquid tube grommet in the small-parts bag and slide it onto the liquid refrigerant line (field line-set).
2. Remove the lower door. Remove the tubing plate (with suction tube grommet) and slide the plate with grommet onto the refrigerant lines (field line-set), away from braze joints.
3. Remove rubber plugs from coil stubs using a pulling and twisting motion. Hold coil stubs steady to avoid bending or distorting.
4. Wrap TXV and nearby tubing with a heat-sinking material such as a wet cloth.
5. Fit refrigerant lines into coil stubs. Wrap a heat sinking material such as a wet cloth behind braze joints.
6. Braze using a Sil-Fos or Phos-copper alloy.
7. After brazing, allow joints to cool. Slide tubing plate back into place and position grommets around suction and liquid tubes to ensure air seal.

**⚠ CAUTION**

**PRODUCT DAMAGE HAZARD**

Failure to follow this caution may result in product damage.

**Braze with Sil-Fos or Phos-copper alloy on copper-to-copper joints and wrap a wet cloth around rear of fitting to prevent damage to TXV.**

## CONDENSATE DRAINS

Unit is provided with primary and secondary 3/4" (19mm) NPT drain connections. Refer to Figures 2, 3, 4, 5, and 6 to identify the primary and secondary locations. To prevent property damage and achieve optimum drainage performance, BOTH primary and secondary drain lines should be installed and include properly sized condensate traps (refer to Figure 18). Factory approved condensate traps are available (accessory part number EBAC01CTK).

To connect drainlines, the drain connection knock-outs must be removed. Use a knife to start the opening near the tab and using pliers, pull the tab to remove the knock-out. Clean the edge of the opening if necessary. After drain fittings are installed, caulk the seam between the fitting and the cover to retain the low leak rating of the unit.

It is recommended the PVC fittings be used on the plastic condensate pan. Do not over-tighten. Finger-tighten plus 1-1/2 turns. Use pipe dope, to ensure proper seal.

Install traps in the condensate lines as close to the coil as possible (refer to Figure 20), but avoid blocking filter access panel.

Install drain lines below the bottom of the drain pan and pitch the drain lines down from the coil at least 1/4 inch per foot of run (6mm per 0.3m). Horizontal runs over 15 feet (5m) long must also have an anti-siphon air vents (stand pipes), installed ahead of the horizontal runs. Extremely long horizontal runs may require oversized drain lines to eliminate air trapping.

Route primary drain line to the outside or to a floor drain. Check local codes before connecting to a waste (sewer) line.

Route the secondary drain line to a place in compliance with local installation codes where it will be noticed when unit is operational. Condensate flowing from secondary (overflow) drain indicates a plugged primary drain - unit requires service or water damage will occur.

**Prime all traps**, test for leaks, and insulate in areas where sweating of the traps and drain lines could potentially cause water damage. Consult local codes for additional requirements or precautions.

If a gravity drain cannot be used, install a condensate pump. Install the pump as close to the indoor section as possible.

**⚠ CAUTION**

**PRODUCT or PROPERTY DAMAGE HAZARD**

Failure to follow this caution may result in product or property damage.

Use only full size P-traps in the condensate line (refer to Figure 18). Shallow, running traps are inadequate and **DO NOT** allow proper condensate drainage (refer to Figure 19).

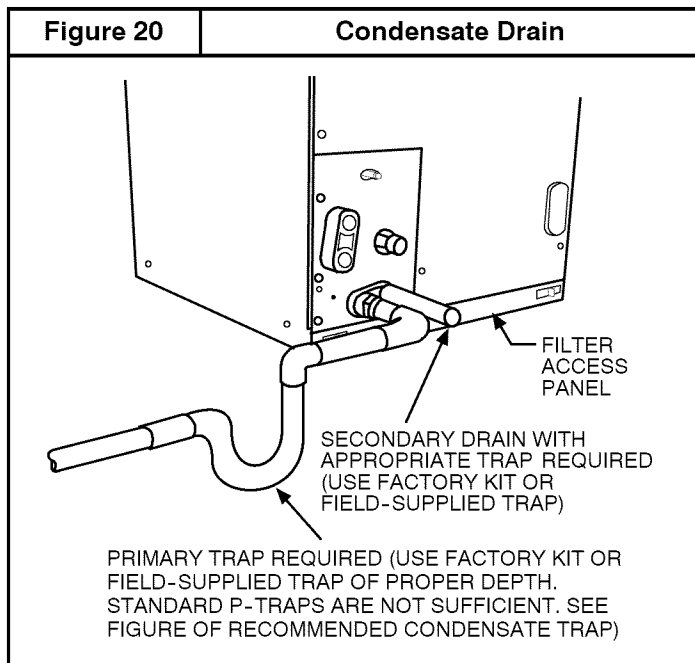
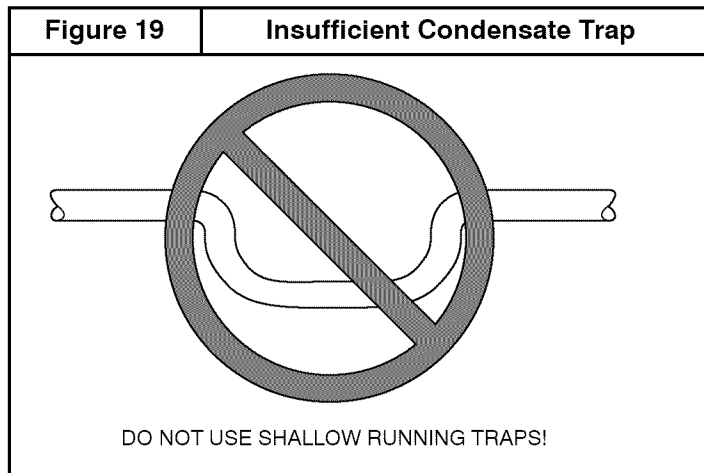
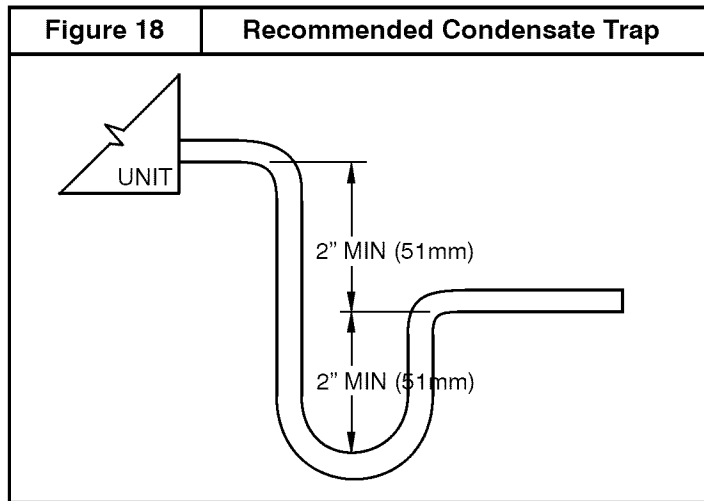

**ACCESSORIES**

**A. ELECTRONIC AIR CLEANER**

The Electronic Air Cleaner may be connected to FSM4X and FSU4X fan coils as shown in Figure 21. This method requires a field supplied transformer. See Electronic Air Cleaner literature for kit requirements.

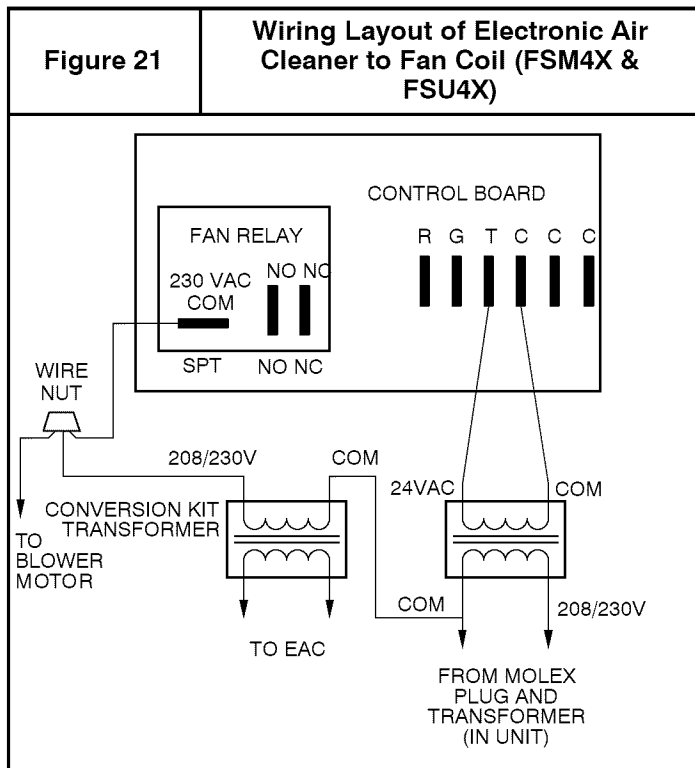

**B. HUMIDIFIER**

Connect humidifier and humidistat to fan coil unit as shown in Figure 22 and Figure 23.

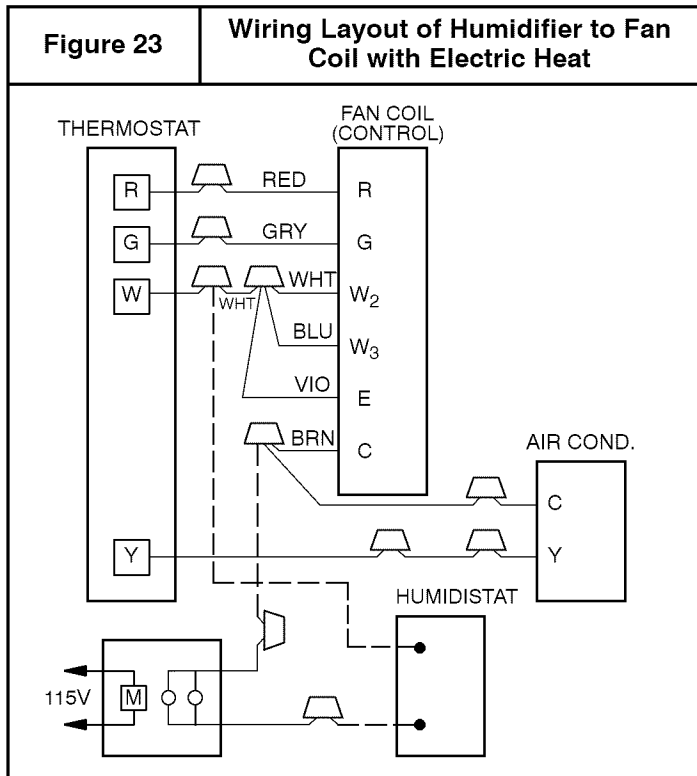
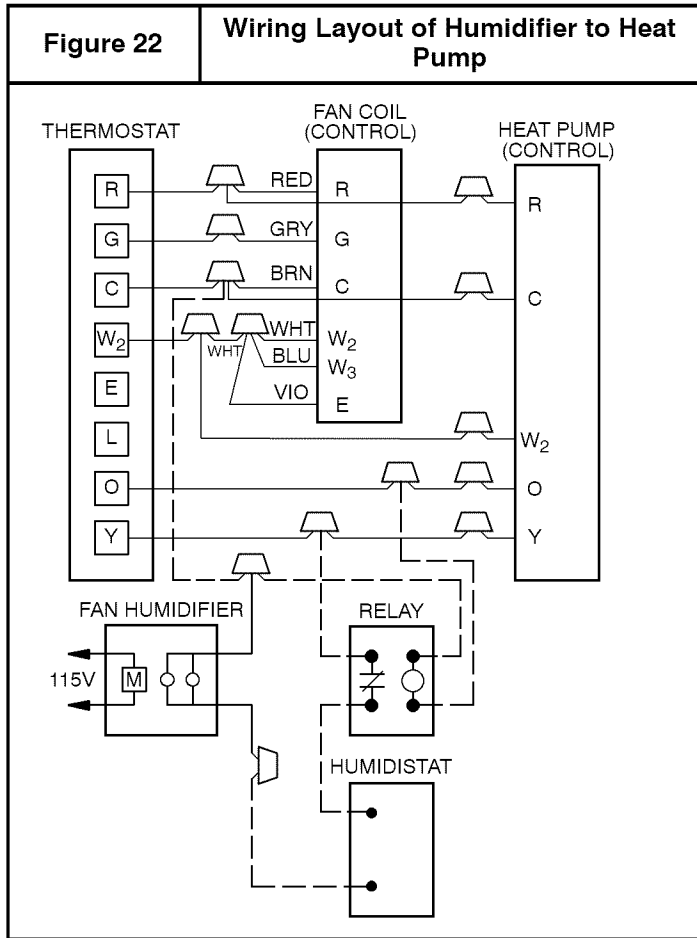

**SEQUENCE OF OPERATIONS**

**A. CONTINUOUS FAN**

Thermostat closes R to G. G energizes fan relay on electronic fan board which completes circuit to indoor blower motor. When G is de-energized, there is a 90 second off delay before relay opens.

**B. COOLING MODE**

Thermostat energizes R to G, R to Y, and R to O (heat pump only). G energizes fan relay on electronic fan board which completes circuit to indoor blower motor. When G is de-energized, there is a 90 second off delay before fan relay opens.

**C. HEAT PUMP HEATING MODE**

Thermostat energizes R to G and R to Y. G energizes fan relay on electronic fan board which completes circuit to indoor blower motor. When G is de-energized, there is a 90 second off delay before fan relay opens.

**D. HEAT PUMP HEATING WITH AUXILIARY ELECTRIC HEAT**

Thermostat energizes R to G, R to Y, and R to W. G energizes fan relay on PCB which completes circuit to indoor blower motor. W energizes electric heat relay(s) which completes circuit to heater element(s). When W is de-energized, electric heat relay(s) open, turning off heater elements. When G is de-energized there is a 90 second off delay before fan relay opens.

**E. ELECTRIC HEAT OR EMERGENCY HEAT MODE**

Thermostat closes R to W. W energizes electric heat relay(s) which completes circuit to heater element(s). Blower motor is energized through normally closed contacts on fan relay. When W is de-energized, electric heat relay(s) opens.

**START-UP PROCEDURE**

Refer to outdoor unit Installation Instructions for system start-up instructions and charging method details.

**CARE AND MAINTENANCE**

The system should be regularly inspected by a qualified service technician. Consult the servicing dealer for recommended frequency.

Between visits, the only consumer service recommended or required is air filter maintenance and condensate drain operation.

**Air Filter**

Inspect air filters at least monthly and replace or clean as required. Disposable type filters should be replaced. Reusable type filters may be cleaned by soaking in mild detergent and rinsing with cold water. Install filters with the arrows on the side pointing in the direction of air flow.

**Condensate Drain**

During the cooling season check at least monthly for free flow of drainage and clean if necessary.

**⚠ CAUTION**

**PRODUCT DAMAGE HAZARD**

Failure to follow this caution may result in poor unit performance and/or product damage.

Never operate unit without a filter. Factory authorized filter kits must be used when locating the filter inside the unit. For those applications where access to an internal filter is impractical, a field-supplied filter must be installed in the return duct system.

**AIRFLOW PERFORMANCE TABLES**

AIRFLOW PERFORMANCE - CFM at a given Speed and Static reading							
Model	Blower Speed	Measured Static Pressure, inlet to outlet (inches water column)					
		0.10	0.20	0.30	0.40	0.50	0.60
FEM4X1800	High	766	739	706	666	619	566
	Medium	701	659	619	578	538	499
	Low	614	572	530	486	441	396
FEM4X2400	High	941	905	868	830	792	753
	Medium	823	786	747	707	665	622
	Low	633	583	533	482	431	378
FEM4X3000	High	1130	1097	1063	1028	992	955
	Medium	1033	1000	965	928	888	846
	Low	840	802	760	713	663	609
FEM4X3500	High	1437	1398	1354	1308	1257	1204
	Medium	1282	1238	1192	1142	1090	1036
	Low	1168	1118	1067	1014	959	903
FEM4X3600	High	1479	1437	1392	1344	1293	1240
	Medium	1327	1282	1236	1187	1135	1081
	Low	1192	1151	1100	1039	970	890
FEM4X4200	High	1616	1578	1533	1480	1420	1353
	Medium	1479	1437	1392	1344	1293	1240
	Low	1303	1258	1211	1161	1108	1054
FEM4X4800	High	1805	1772	1739	1704	1669	1632
	Medium	1652	1617	1581	1543	1504	1463
	Low	1458	1418	1377	1335	1292	1248
AIRFLOW PERFORMANCE - CFM at a given Speed and Static reading							
Model	Blower Speed	Measured Static Pressure, inlet to outlet (inches water column)					
		0.10	0.20	0.30	0.40	0.50	0.60
FEM4X6000	Tap 5	1897	1867	1836	1808	1774	1736
	Tap 4	1817	1785	1757	1724	1693	1655
	Tap 3	1817	1785	1757	1724	1693	1655
	Tap 2	1657	1621	1589	1557	1518	1474
	Tap 1	1443	1412	1377	1332	1286	1243
AIRFLOW PERFORMANCE - CFM at a given Speed and Static reading							
Model	Blower Speed	Measured Static Pressure, inlet to outlet (inches water column)					
		0.10	0.20	0.30	0.40	0.50	0.60
FSM4X6000 FSU4X6000	High	2128	2050	1965	1875	1778	1674
	Medium	1959	1898	1829	1750	1663	1566
	Low	1748	1709	1659	1598	1525	1442

**AIRFLOW PERFORMANCE - CFM at a given Speed and Static reading**

Model	Blower Speed	Measured Static Pressure, inlet to outlet (inches water column)					
		0.10	0.20	0.30	0.40	0.50	0.60
FXM4X1800	Tap 5	776	745	696	660	609	572
	Tap 4	683	644	589	548	494	461
	Tap 3	683	644	589	548	494	461
	Tap 2	631	563	500	443	409	361
	Tap 1	625	524	457	417	367	319
FXM4X2400	Tap 5	956	920	891	851	816	780
	Tap 4	825	795	757	722	674	634
	Tap 3	825	795	757	722	674	634
	Tap 2	726	695	635	598	543	509
	Tap 1	631	563	500	443	409	361
FXM4X3000	Tap 5	1189	1151	1104	1050	1003	959
	Tap 4	1041	998	944	886	837	772
	Tap 3	1041	998	944	886	837	772
	Tap 2	924	876	817	752	704	660
	Tap 1	779	693	628	571	526	476
FXM4X3600	Tap 5	1363	1332	1294	1253	1207	1157
	Tap 4	1237	1206	1160	1121	1070	1013
	Tap 3	1237	1206	1160	1121	1070	1013
	Tap 2	1095	1058	1007	951	888	824
	Tap 1	1014	885	773	673	609	549
FXM4X4200	Tap 5	1519	1490	1454	1419	1379	1332
	Tap 4	1437	1403	1366	1333	1294	1245
	Tap 3	1437	1403	1366	1333	1294	1245
	Tap 2	1257	1226	1191	1141	1090	1033
	Tap 1	1237	1206	1160	1121	1070	1013
FXM4X4800	Tap 5	1757	1725	1693	1653	1614	1576
	Tap 4	1664	1626	1593	1552	1517	1477
	Tap 3	1664	1626	1593	1552	1517	1477
	Tap 2	1459	1420	1379	1336	1298	1259
	Tap 1	1301	1241	1195	1150	1102	1039
FXM4X6000	Tap 5	2030	1995	1961	1927	1888	1842
	Tap 4	1811	1775	1740	1703	1664	1613
	Tap 3	1811	1775	1740	1703	1664	1613
	Tap 2	1665	1632	1593	1556	1507	1453
	Tap 1	1462	1418	1371	1327	1278	1228

**NOTES:**

1. Airflow based upon dry coil at 230v with factory approved filter and electric heater (2 element heater sizes 1800 through 3600, 3 element heater sizes 4200 through 6000).
2. Airflow at 208 volts is approximately the same as 230 volts because the ECM motor is a constant torque motor. The torque doesn't drop off at the speeds the motor operates.
3. To avoid potential for condensate blowing out of drain pan prior to making drain trap: Return static pressure must be less than 0.40 in. wc. Horizontal applications of 4200 - 6000 sizes must have supply static greater than 0.20 in. wc.
4. Airflow above 400 cfm/ton on 4800 - 6000 size could result in condensate blowing off coil or splashing out of drain pan.
5. Not recommended for use above 0.60 inches water column external static pressure.
6. Shading - Airflow outside 450 cfm/ton.

STATIC PRESSURE DROP ACROSS FILTER (inches of water column)									
FEM4X	CFM								
	400	600	800	1000	1200	1400	1600	1800	2000
1800	0.020	0.044	0.075	—	—	—	—	—	—
2400	—	0.044	0.075	0.110	—	—	—	—	—
3000	—	—	0.048	0.072	0.100	—	—	—	—
3500 3600	—	—	—	0.072	0.100	0.130	—	—	—
4200	—	—	—	—	0.070	0.092	0.120	—	—
4800	—	—	—	—	—	0.092	0.120	0.152	—
6000	—	—	—	—	—	—	0.086	0.105	0.130

STATIC PRESSURE CORRECTION FROM DRY TO WET COIL (inches of water column)																
Airflow performance chart was developed using fan coils with DRY coils. When taking a static reading across a WET coil, adjust the static pressure numbers by <b>adding</b> the values in this table (for a given CFM, wet coil will have greater static pressure drop than dry coil).																
FEM4X	CFM															
	500	600	700	800	900	1000	1100	1200	1300	1400	1500	1600	1700	1800	1900	2000
1800	0.034	0.049	0.063	—	—	—	—	—	—	—	—	—	—	—	—	—
2400	0.016	0.027	0.038	0.049	0.059	—	—	—	—	—	—	—	—	—	—	—
3000	—	—	—	0.049	0.059	0.070	0.080	—	—	—	—	—	—	—	—	—
3500	—	—	—	—	—	0.055	0.064	0.073	0.081	—	—	—	—	—	—	—
3600	—	—	—	—	—	0.034	0.042	0.049	0.056	—	—	—	—	—	—	—
4200	—	—	—	—	—	—	—	0.049	0.056	0.063	0.070	—	—	—	—	—
4800	—	—	—	—	—	—	—	—	—	0.038	0.043	0.049	0.054	0.059	—	—
6000	—	—	—	—	—	—	—	—	—	—	—	0.049	0.054	0.059	0.065	0.070

STATIC PRESSURE DROP ACROSS FILTER (inches of water column)									
FSM4X FSU4X	CFM								
	400	600	800	1000	1200	1400	1600	1800	2000
6000	—	—	—	—	—	—	0.120	0.152	0.187

STATIC PRESSURE CORRECTION FROM DRY TO WET COIL (inches of water column)																
Airflow performance chart was developed using fan coils with DRY coils. When taking a static reading across a WET coil, adjust the static pressure numbers by <b>adding</b> the values in this table (for a given CFM, wet coil will have greater static pressure drop than dry coil).																
FSM4X FSU4X	CFM															
	500	600	700	800	900	1000	1100	1200	1300	1400	1500	1600	1700	1800	1900	2000
6000	—	—	—	—	—	—	—	—	—	—	—	0.027	0.031	0.035	0.039	0.043



**STATIC PRESSURE DROP ACROSS FILTER (inches of water column)**

FXM4X	CFM								
	400	600	800	1000	1200	1400	1600	1800	2000
1800	0.020	0.044	0.075	—	—	—	—	—	—
2400	—	0.022	0.048	0.072	0.100	—	—	—	—
3000	—	0.022	0.048	0.072	0.100	—	—	—	—
3600	—	—	—	0.051	0.070	0.092	0.120	0.152	—
4200	—	—	—	0.051	0.070	0.092	0.120	0.152	—
4800	—	—	—	0.051	0.070	0.092	0.120	0.152	—
6000	—	—	—	—	—	—	0.086	0.105	0.130

**STATIC PRESSURE CORRECTION FROM DRY TO WET COIL (inches of water column)**

Airflow performance chart was developed using fan coils with DRY coils.

When taking a static reading across a WET coil, adjust the static pressure numbers by **adding** the values in this table (for a given CFM, wet coil will have greater static pressure drop than dry coil).

FXM4X	CFM															
	500	600	700	800	900	1000	1100	1200	1300	1400	1500	1600	1700	1800	1900	2000
1800	0.034	0.049	0.063	—	—	—	—	—	—	—	—	—	—	—	—	—
2400	0.016	0.027	0.038	0.049	0.059	—	—	—	—	—	—	—	—	—	—	—
3000	—	—	—	0.049	0.059	0.070	0.080	—	—	—	—	—	—	—	—	—
3600	—	—	—	—	—	0.055	0.064	0.073	0.081	—	—	—	—	—	—	—
4200	—	—	—	—	—	—	—	0.049	0.056	0.063	0.070	—	—	—	—	—
4800	—	—	—	—	—	—	—	—	—	0.038	0.043	0.049	0.054	0.059	—	—
6000	—	—	—	—	—	—	—	—	—	—	—	0.027	0.031	0.035	0.039	0.043

**STATIC PRESSURE CORRECTION FOR ELECTRIC HEATERS (inches of water column)**

Airflow performance chart was developed using fan coils with 10 kW electric heater (2 elements) in the 1800 – 3600 model sizes, and 15 kW electric heaters (3 elements) in the 4200 – 6000 model sizes.

When using a different number of heater elements, adjust the static pressure numbers by adding or subtracting the values in this table (for a given CFM, more electric heater elements create higher static pressure drop).

FEM4X FSM4X FSU4X FXM4X	Heater kW					
	No Heater	5	8 or 10	9 or 15	20	18, 24, or 30
	Number of Heat Elements					
	0	1	2	3	4	6
1800	+0.02	+0.01	0	-0.02	-0.04	-
2400	+0.02	+0.01	0	-0.02	-0.04	-
3000	+0.02	+0.01	0	-0.02	-0.04	-
3500	+0.02	+0.01	0	-0.02	-0.04	-
3600	+0.02	+0.01	0	-0.02	-0.04	-
4200	+0.04	-	+0.02	0	-0.02	-0.10
4800	+0.04	-	+0.02	0	-0.02	-0.10
6000	+0.04	-	+0.02	0	-0.02	-0.10

## R-410A QUICK REFERENCE GUIDE

---

- R-410A refrigerant operates at 50% - 70% higher pressures than R-22. Be sure that servicing equipment and replacement components are designed to operate with R-410A.
- R-410A refrigerant cylinders are rose colored.
- Recovery cylinder service pressure rating must be 400 psig, DOT 4BA400 or DOT BW400.
- R-410A systems should be charged with liquid refrigerant. Use a commercial type metering device in the manifold hose.
- Manifold sets should be 750 psig high-side and 200 psig low-side with 520 psig low-side retard.
- Use hoses with 750 psig service pressure rating.
- Leak detectors should be designed to detect HFC refrigerant.
- R-410A, as with other HFC refrigerants, is only compatible with POE oils.
- POE oils absorb moisture rapidly. Do not expose oil to atmosphere.
- POE oils may cause damage to certain plastics and roofing materials.
- Vacuum pumps will not remove moisture from oil.
- A liquid line filter-drier is required on every unit.
- Do not use liquid line filter-driers with rated working pressures less than 600 psig.
- Do not install a suction line filter-drier in liquid line.
- Wrap all filter-driers and service valves with wet cloth when brazing.
- Do not use with an R-22 TXV.
- If indoor unit is equipped with an R-22 TXV, it must be changed to an R-410A TXV.
- Do not use capillary tube indoor coils.
- Never open system to atmosphere while it is under a vacuum.
- When system must be opened for service, break vacuum with dry nitrogen and replace all filter-driers.
- Do not vent R-410A into the atmosphere.
- Observe all **WARNINGS, CAUTIONS, NOTES**, and **bold** text.