

5KFC3511,
KJA03

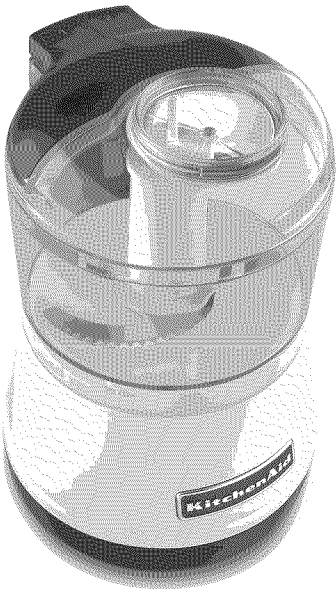

KitchenAid

Table of Contents

FOOD CHOPPER SAFETY	
Important Safeguards.....	4
Electrical Requirements.....	6
TROUBLESHOOTING	6
PARTS AND FEATURES GUIDE	7
OPERATING YOUR FOOD CHOPPER	
Before First Use.....	8
Disassembling the Food Chopper.....	8
Using the Food Chopper.....	9
Removing Ingredients.....	9
Operating Tips for Great Results.....	10
CARE AND CLEANING	10

Food Chopper Safety

Your safety and the safety of others are very important.

We have provided many important safety messages in this manual and on your appliance. Always read and obey all safety messages.



This is the safety alert symbol.

This symbol alerts you to potential hazards that can kill or hurt you and others.

All safety messages will follow the safety alert symbol and either the word “DANGER” or “WARNING.” These words mean:

! DANGER

You can be killed or seriously injured if you don't immediately follow instructions.

! WARNING

You can be killed or seriously injured if you don't follow instructions.

All safety messages will tell you what the potential hazard is, tell you how to reduce the chance of injury, and tell you what can happen if the instructions are not followed.

IMPORTANT SAFEGUARDS

When using electrical appliances, basic safety precautions should always be followed, including the following:

1. Read all instructions. Misuse of the appliance may result in personal injury.
2. To protect against risk of electrical shock do not put motor body, cord or electrical plug of this Food Chopper in water or other liquid.
3. This appliance shall not be used by children.
4. Unplug from outlet when not in use, before putting on or taking off parts, and before cleaning.
5. Avoid contacting moving parts.
6. Do not operate any appliance with a damaged cord or plug or after the appliance malfunctions, or is dropped or damaged in any manner. Return appliance to the nearest Authorized Service Facility for examination, repair or electrical or mechanical adjustment in order to avoid a hazard.
7. The use of attachments not recommended or sold by the manufacturer may cause fire, electric shock or injury.
8. Do not use outdoors.
9. Do not let cord hang over edge of table or counter. Keep the appliance and its cord out of reach of children.
10. Keep hands and utensils away from the cutting blade while chopping food to reduce the risk of severe injury to person or damage to the Food Chopper. A scraper may be used but only when the Food Chopper is not running.
11. Blade is sharp, handle carefully. Care shall be taken when handling sharp cutting blades, emptying the bowl and during cleaning.
12. To reduce the risk of injury, never place cutting blade on base without first putting bowl properly in place.

13. Be certain cover is securely locked in place before operating Food Chopper.
14. Do not attempt to defeat the cover interlock mechanism.
15. To disconnect, turn any control to “OFF,” then remove plug from wall outlet.
16. This appliance is not intended for use by persons (including children) with reduced physical, sensory, or mental capabilities, or lack of experience and knowledge, unless they have been given supervision or instruction concerning use of the appliance, in a safe way, by a person responsible for their safety and if they understand the hazards involved.
17. This appliance is intended to be used in household and similar applications such as:
 - staff kitchen areas in shops, offices, and other working environments.
 - farm houses.
 - by clients in hotels, motels, and other residential type environments.
 - bed and breakfast type environments.
18. Be careful if hot liquid is poured into the appliance as it can be ejected out of the appliance due to a sudden steaming.

SAVE THESE INSTRUCTIONS

This product is designed for household use only.

Food Chopper Safety

Electrical Requirements

Australia, China, S. Korea, Asia
Volts: 220-240 V.A.C.
Hertz: 50/60 Hz

Brazil
Volts: 127 V.A.C.
Hertz: 60 Hz

A short power-supply cord is provided to reduce the risk resulting from becoming entangled in or tripping over a longer cord.

Extension cords are available and may be used if care is exercised in their use.

If a longer extension cord is used:

- The marked electrical rating of the extension cord should be at least as great as the electrical rating of the appliance.
- The cord should be arranged so it will not drape over the countertop or tabletop where it can be pulled on by children or tripped over unintentionally.

Troubleshooting

Keep a copy of the sales receipt showing the date of purchase. Proof of purchase will assure you of in-warranty service.

If your Food Chopper should malfunction or fail to operate, check the following:

- Make sure that the bowl and lid are properly aligned and locked in place.
- Press only one button at a time. The Food Chopper will not operate if both buttons are pressed at the same time.
- Is the Food Chopper plugged in?
- Is the fuse in the circuit to the Food Chopper in working order? If you have a circuit breaker box, be sure the circuit is closed.
- Unplug the Food Chopper, then plug it back into the outlet.
- If the Food Chopper is not at room temperature, wait until unit reaches room temperature and retry.

Parts and Features Guide

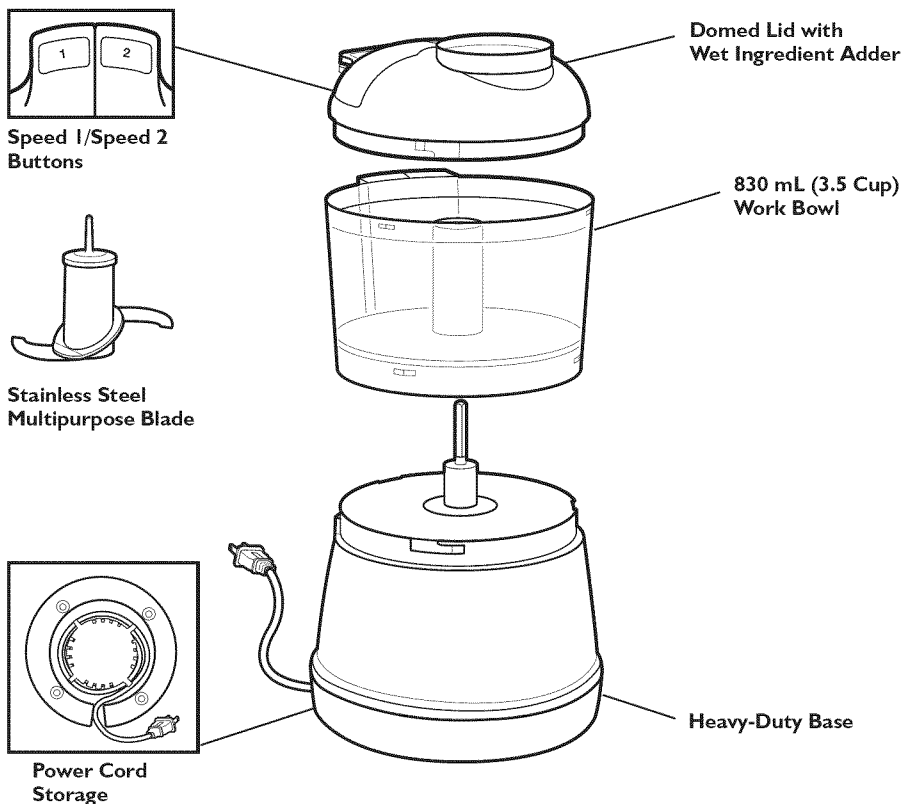

Speed 1/Speed 2 Buttons

The Food Chopper features easy one handed operation with top-mounted buttons. 2 speeds provide optimal results, regardless of the task: Use the **Speed 1** for everyday chopping needs. Use the higher **Speed 2** to quickly purée ingredients.

Stainless Steel Multipurpose Blade

This strong, razor-sharp blade quickly processes small amounts of meats, fresh or cooked fruits and vegetables, and nuts and herbs. Blade locks on the shaft to stay in place while you pour out ingredients. Reverse spiral design pulls foods down into blade for uniform chopping, and minimizes need to scrape sides of bowl. The blade is dishwasher-safe.

Domed Lid with Wet Ingredient Adder

The domed lid locks into place to operate the Food Chopper, and removes easily to add ingredients. A wet ingredient adder hole and well in the lid allows you to add liquid ingredients without removing the lid. The lid is dishwasher-safe.

830 mL (3.5 Cup) Work Bowl

The BPA-free 830 mL (3.5 cup) capacity bowl provides a generous working capacity, and removes easily from the base. The work bowl is dishwasher-safe.

Power Cord Storage

The power cord wraps under the base for convenient storage.

Operating Your Food Chopper

⚠️ WARNING

Cut Hazard

Handle blades carefully.

Failure to do so can result in cuts.

Before First Use

1. Before using the KitchenAid Food Chopper for the first time, wash the work bowl, lid, and blade with soap and hot water. Work bowl, lid, and blade may also be washed in the top rack of a dishwasher.
2. Read Food Chopper Operating Tips for recommendations on how to get consistently great results.

Disassembling the Food Chopper

To disassemble the Food Chopper for cleaning and when removing ingredients from the bowl, follow the instructions below:

1. Be sure the Food Chopper is unplugged.
2. Holding the lid as shown, twist lid clockwise to unlock, and lift off the bowl.

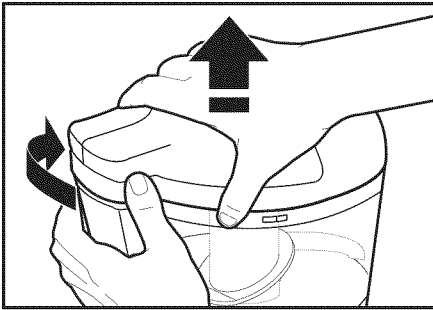

3. Pull the blade straight up to unlock and remove it from the bowl.

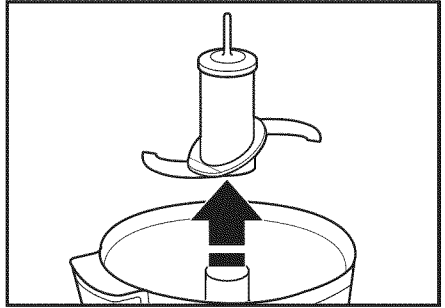

4. Holding the bowl as shown, twist bowl clockwise to unlock, and lift off the base.

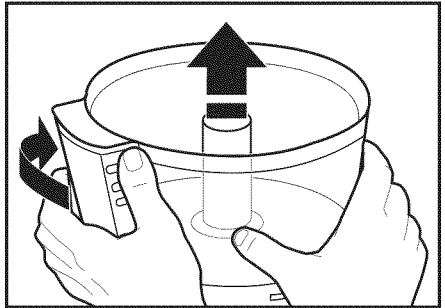

Operating Your Food Chopper

Using the Food Chopper

1. Be sure the Food Chopper is unplugged.
2. Align the tabs on the work bowl with the L-slots on the base. Twist bowl counterclockwise to lock into place.

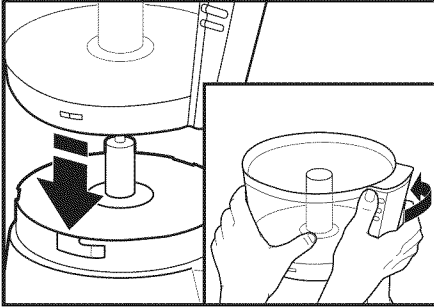

3. Fit the blade over the shaft in the center of the work bowl, rotate, and press down until it locks into operating position.

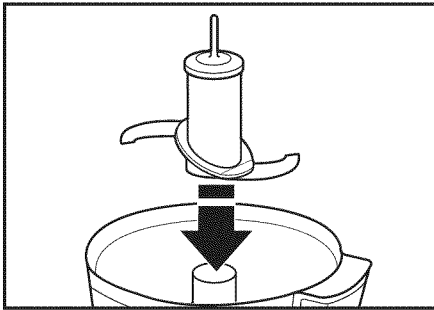

4. Place ingredients to be processed into the work bowl.

5. Place the lid on the workbowl, aligning the L-slots on the lid with the tabs on the work bowl. Twist lid counterclockwise to lock into place as shown below.

NOTE: Bowl and lid must be locked in place for the Food Chopper to operate.

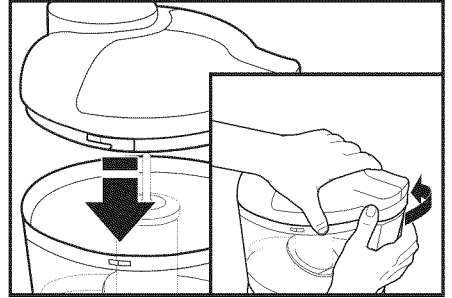

6. Plug power cord into electrical outlet.
7. Press and hold Speed 1 or Speed 2 button to start processing. Do not exceed continuous 30 second maximum run time.

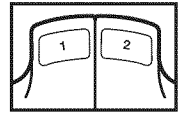

NOTE: Food Chopper will not operate if both buttons are pressed at the same time.

8. Use the wet ingredient adder to add liquid ingredients while processing, if desired. See “Operating Tips for Great Results”.
9. When ingredients are chopped to the desired consistency, release the Speed 1 or Speed 2 button.

Removing Ingredients

1. Once the blade has stopped spinning, remove lid by twisting it clockwise and lifting it off.
2. Remove the work bowl from the base by twisting it clockwise and lifting it off. Blade locks on the shaft to stay in place while you pour out ingredients.
3. Use a spatula to remove ingredients from the work bowl.
4. To remove blade for cleaning, pull the blade straight up to unlock and remove it from the bowl.

Operating Your Food Chopper

Operating Tips for Great Results

1. To achieve optimal results when grinding raw meat, use Speed 2 to grind up to 225g (1/2 pound) of meat at one time.

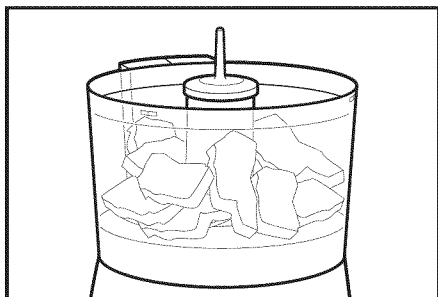
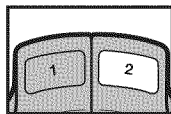

2. For best processing results, press and release the Speed 1 or Speed 2 button. Do not exceed continuous 30 second maximum run time. Repeat until ingredients reach the consistency you want.
3. Use the wet ingredient adder to add liquid ingredients such as olive oil during processing.

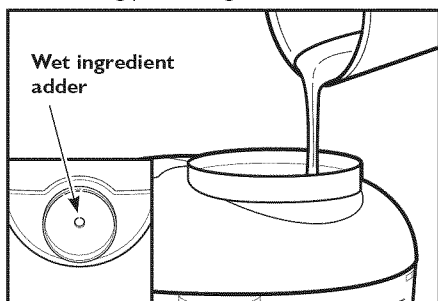

4. Use your Food Chopper to make bread, cracker, or cookie crumbs. Break bread, crackers, or cookies into small pieces, add to work bowl and process into crumbs.
5. For uniform consistency of processed foods, cut carrots, celery, mushrooms, green peppers, onions and similar vegetables into 2.5 cm (1-inch) pieces before adding to work bowl.

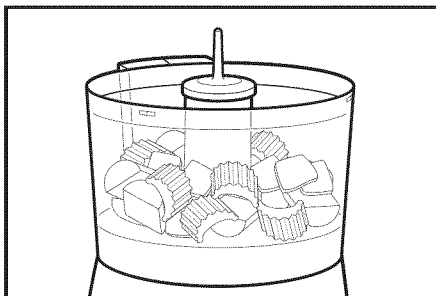

6. Use your Food Chopper to chop nuts and mince parsley, basil, chives, garlic and other herbs.
7. Make baby food by using your Food Chopper to purée cooked fruit or vegetables. Puréed, cooked fruits and vegetables can also be used as bases for soups or sauces.
8. Do not use your Food Chopper to process coffee beans or hard spices such as nutmegs. Processing these foods could damage the Food Chopper.
9. Do not use your Food chopper to chop food more than 30 seconds continuously.

Care and Cleaning

⚠ WARNING

Cut Hazard

Handle blades carefully.

Failure to do so can result in cuts.

1. Unplug the Food Chopper.
2. Remove the work bowl, lid and blade. Wash with soap and hot water. Rinse and dry. Work bowl, lid, and blade can also be washed in the top dishwasher rack.
3. Wipe the base clean with a damp cloth. Do not use abrasive cleaners. Do not immerse the base in water.
4. To protect the blade, always reassemble your Food Chopper after cleaning.

