

EN ICE MAKER
FR ICE MAKER
ES ICE MAKER

USE AND CARE GUIDE
GUIDE D'UTILISATION ET D'ENTRETIEN
GUIA DE USO Y CUIDADO

2 Finding Information

Please Read and Save This Guide

Thank you for choosing Electrolux, the new premium brand in home appliances. This Use & Care Guide is part of our commitment to customer satisfaction and product quality throughout the service life of your new ice maker.

We view your purchase as the beginning of a relationship. To ensure our ability to continue serving you, please use this page to record key product information.



IMPORTANT

PLEASE READ all instructions completely before attempting to install or operate the unit.

All ice makers require a connection to both a water supply and an electrical power source. Improper hook-up can result in substantial property damage! Proper installation, in accordance with the manufacturer's specifications and all local codes, is the sole responsibility of the consumer. The manufacturer is not responsible for any installation expenses or damages incurred due to improper installation. If you are unsure of your ability to safely make electric power, water supply, and water drain connections to the unit, consult licensed and insured professionals to perform all electrical and plumbing work.

Once you have your unit installed, we suggest you keep this manual in a safe place for future reference. Should any problems occur, refer to the Troubleshooting section of this manual. This information will help you quickly identify a problem and get it remedied. In the event you require assistance, please contact the dealer where you purchased your unit.

Keep a record for quick reference

Whenever you call to request information or service, you will need to know your model number and serial number. You can find this information on the serial plate located on the inside wall of your unit and on the product registration card.



NOTE

Registering your product with Electrolux enhances our ability to serve you. You can register online at www.electroluxappliances.com or by dropping your Product Registration Card in the mail. Complete and mail the Product Registration Card as soon as possible to validate the registration date.

Please record the purchase date of your Electrolux unit and your dealer's name, address and telephone number.

Purchase Date

Electrolux Model Number

Electrolux Serial Number

Dealer Name

Dealer Address

Dealer Telephone

Keep this manual and the sales receipt together in a safe place for further reference.

Questions?

For toll-free telephone support in the U.S. and Canada: 1-877- 4ELECTROLUX (1-877-435-3287)

For online support and Internet product information: www.electroluxappliances.com

Table of Contents

Finding Information	2	Options Menu.....	16
Please Read and Save this Guide.....	2	Normal and ECO Mode	16
Keep a Record for Quick Reference	2	Clean Mode.....	16
Questions?	2	Once You have your Cleaner	16
Table of Contents.....	3		
Safety	4	Maintenance	18
Important Safety Instructions	4	Special Considerations	18
Safety Precautions.....	4	Maintaining & Cleaning your Ice Maker.....	18
Definitions.....	4	Exterior Cleaning - As Required.....	18
General Precautions	4	Stainless Steel Models.....	18
		Interior Cleaning - As Required.....	18
Site Preparation	5	Condenser Cleaning - Every 3 Months	19
Preparing the Site	5	Automatic Cleaning - Every 6 Months.	19
		Preparing the Ice Machine for Storage	20
Installation	6	Clean the Ice Maker.....	20
Select Location	6	Draining & Removing Water	
Cabinet Clearance	6	from the Ice Making System	
Installing the Drain.....	6	with a Gravity Drain	20
Drain Plumbing	6	Draining Water for Factory In-	
Installation Dimensions	7	stalled Drain Pump Application...21	
Factory Installed Drain Pump.....	7	To Restart the Ice Maker.....	22
Connecting the Water Supply	8	Drain Pump Removal Instructions.....	23
Electrical Connection	9		
Leveling Legs.....	10	Troubleshooting	24
Leveling the Unit	10	Before you Call for Service.....	24
		Troubleshooting Guide.....	24
Door Adjustment	11	Troubleshooting the Drain Pump.....	28
Adjusting the Door	11	If Service is Required	28
		Warranty Information	29
Operation of Ice Machine	12		
Ice Making Process	12		
Ice Production	12		
New Sounds.....	13		
Built-In Installation/Start-Up	14		
Installing a Built-In	14		
Initial Start-Up	14		
Using your Electronic Control.....	14		
Display Icons	14		
Display Area Text	14		
Starting your Clear Ice Machine....	15		
Turning your Ice Machine On/Off ..	15		
Control Lock.....	15		
Delay Start/Vacation Mode	15		
Clean Reminder.....	15		
Door Ajar Alarm	16		



WARNING

You must follow these guidelines to ensure that your refrigerator's safety mechanisms are operating correctly.

4 Safety

Important Safety Instructions

Safety Precautions

Do not attempt to install or operate your unit until you have read the safety precautions in this manual. Safety items throughout this manual are labeled with a Danger, Warning or Caution based on the risk type.

Definitions

 This is the safety alert symbol. It is used to alert you to potential personal injury hazards. Obey all safety messages that follow this symbol to avoid possible injury or death.



DANGER

DANGER indicates an imminently hazardous situation which, if not avoided, will result in death or serious injury.



WARNING

WARNING indicates a potentially hazardous situation which, if not avoided, could result in death or serious injury.



CAUTION

CAUTION indicates a potentially hazardous situation which, if not avoided, may result in minor or moderate injury.



IMPORTANT

Indicates installation, operation, or maintenance information which is important but not hazard-related.

General Precautions



WARNING

RISK OF CHILD ENTRAPMENT. Before you throw away your old appliance, take off the doors and leave shelves in place so that children may not easily climb inside.



IMPORTANT

To turn off power to your ice maker, unplug the power cord from the wall outlet.



WARNING

- Never attempt to repair or perform maintenance on the unit until the electricity has been disconnected.
- Altering, cutting of power cord, removal of power cord, removal of power plug, or direct wiring can cause serious injury, fire and/or loss of property and/or life and will void the warranty.
- Do not lift unit by door handle.



CAUTION

- Use care when moving the unit. Some edges are sharp and may cause personal injury. Wear gloves when moving or repositioning the unit.
- Never install the unit behind closed doors. Be sure front grille is free of obstruction. Obstructing free air flow can cause the unit to malfunction, and may void the warranty.
- Allow unit temperature to stabilize for 24 hours before use.
- Never use an ice pick or other sharp instrument to help speed up defrosting. These instruments can puncture the inner lining or damage cooling unit
- Failure to clean the condenser every three months can cause the unit to malfunction. This could void the warranty.



CAUTION

- Using a heater to speed up defrosting can cause personal injury and damage to the inner lining. DO NOT use any type of heater to defrost.
- Use only genuine Electrolux replacement parts. Imitation parts can damage the unit and may void the warranty.

Preparing the Site



IMPORTANT

It is extremely important that the unit is level. If it is not level, the ice mold will not fill evenly. This can cause a reduction in ice rate, uneven sized cubes or water spilling into the storage area which will cause the ice in the bin to melt pre-maturely. Remember that floors near drains have a tendency to slope towards the drain.

- 1 Position the unit on a flat, level surface, capable of supporting the entire weight of the unit. Remember that the unit will be significantly heavier once it is fully loaded.
- 2 The surrounding air temperature must be at least 50°F (10°C) but must not exceed 110°F (43°C).
- 3 The unit must not be located near heat-generating equipment or in direct sunlight.



DANGER

ELECTROCUTION HAZARD!

Electrical Grounding Required. This appliance is equipped with a three prong (grounding) polarized plug for your protection against possible shock hazards.

- NEVER remove the round grounding prong from the plug.
- NEVER use a two-prong grounding adapter.
- NEVER use an extension cord to connect power to the unit.

Where a two-prong wall receptacle is encountered or a longer power cord is required, contact a qualified electrician to have it replaced in accordance with applicable electrical codes.



IMPORTANT

This unit is designed for indoor use only.

- 4 The unit must be located to allow clearance for water, drain and electrical connections in the rear of the ice maker.

- 5 Connect the unit to a grounded and polarized 115 VAC, 60 Hz, 15 A circuit (normal household current).
- 6 Avoid connecting the unit to a Ground Fault Interrupter (GFI). GFIs are prone to nuisance tripping which will cause the unit to shut down. GFIs are generally not used on circuits which power equipment that must run unattended for long periods of time.
- 7 The unit must be installed according to your local codes and ordinances.



NOTE

The door of this unit is not reversible but a separate model is available with a door that swings open in the opposite direction. Electrolux stainless steel models require a minimum 2-3/4 inch handle clearance when installed against a wall or cabinet that extends beyond the front edge of the unit (Figure 1).

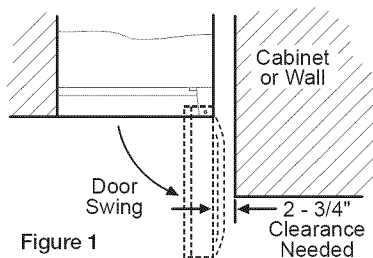

Figure 1

- 8 Position the unit to allow free air flow through the front grille (Figure 2).
- 9 Wipe out inside of unit with a damp cloth.

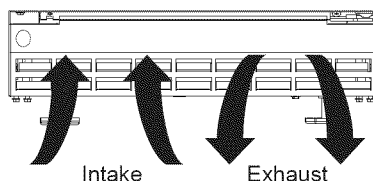

Figure 2

6 Installation

Select Location

The proper location will ensure peak performance of your appliance. We recommend a location where the ice machine will be out of direct sunlight and away from heat sources. To ensure your product performs to specifications, the recommended installation location temperature range is from 55 to 90°F (13 to 32°C) for built in ice machines and 55 to 100°F (13 to 38°C) for freestanding ice machines. Ice machines will not perform correctly in ambient temperatures less than 55°F (13°C). This unit is not intended to be installed outdoors.

Cabinet Clearance

Ventilation is required from the bottom front of the appliance. Keep this area open and clear of any obstructions. Adjacent cabinets and counter top can be installed around the appliance as long as the front grille remains unobstructed.



CAUTION

Do not obstruct the front grille. The openings within the front grille allow air to flow through the condenser heat exchanger. Restrictions to this air flow will result in increased energy usage and loss of cooling capacity. For this reason it is important this area not be obstructed and the grille openings kept clean. Electrolux does not recommend the use of a custom made grille as air flow may be restricted (Figure 1).

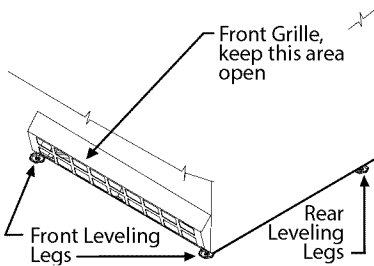

Figure 1

Installing the Drain



CAUTION

PLEASE READ all instructions completely before attempting to install or operate the unit. Plumbing installation must observe all state and local codes. All ice makers require a connection to the water supply and improper hook-up can result in substantial property damage! All water and drain connections **MUST BE** made by a licensed/qualified plumbing contractor. Failure to follow recommendations and instructions may result in damage and/or harm.

Drain Plumbing

Your ice machine requires drain plumbing. Follow these guidelines when installing drain lines to prevent water from flowing back into the ice maker storage bin and/or potentially flowing onto the floor causing water damage.



CAUTION

Observe and follow all local building codes when installing this ice machine and drain lines.

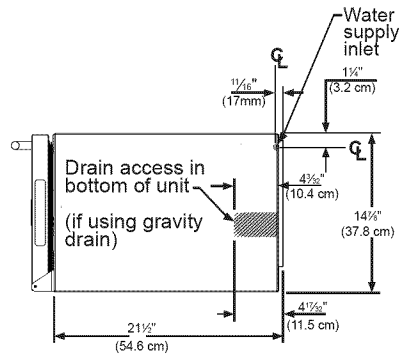

Figure 2



CAUTION

Failure to use an adequate drainage system, will result in surrounding water damage and/or poor ice production.

Installation Dimensions

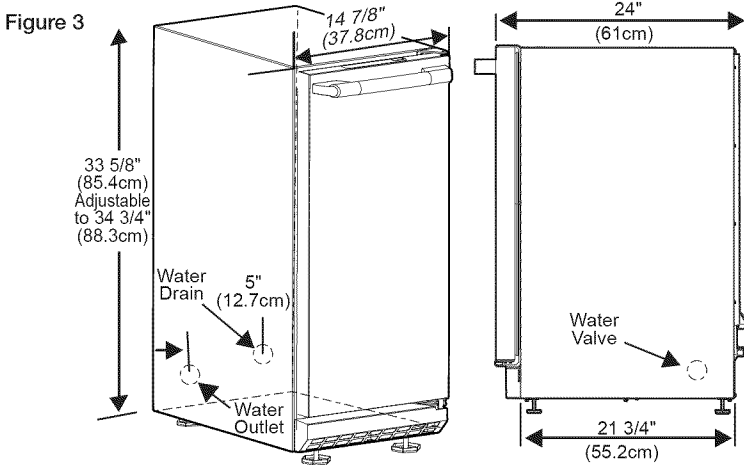

Factory Installed Drain Pump

This pump is designed to remove drain water from ice machines installed in areas without direct drainage access. The sealed reservoir pump collects the melted ice water and pumps it to a maximum lift of eight feet (2.44 meters) through 3/8" I.D. vinyl tubing to a drain.

The discharge tubing is coiled up and attached to the back of the ice machine. The 3/8 inch I.D. tubing needs to be plumbed and connected to a sanitary sewer (Figure 4).



CAUTION

This drain pump is designed to be installed in Electrolux ice machines only and has been evaluated for use with water only. Drain line vertical rise is not to exceed 8 feet and total drain line length is not to exceed 20 feet; otherwise, the ice machine may not operate correctly.



WARNING

Electrical Shock Hazard

Risk of electrical shock or personal injury could occur due to moving components, if the machine compartment access cover is removed before unplugging the ice machine power cord.

Drain line coiled and secured to the back of the cabinet. Uncoil, route to an appropriate drain and cut to length.

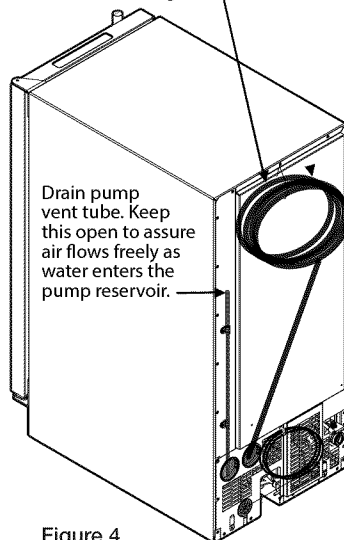

Figure 4

8 Installation

Connecting the Water Supply



CAUTION

Observe and follow all local plumbing codes when installing this appliance. After completing the installation, turn on the water and recheck the drain and water connections for leaks.

This ice machine must be connected to a potable cold water supply line delivering water pressure between a minimum of 20 psi and a maximum of 120 psi.

Use 1/4" copper tubing for your water supply which is available at any local hardware or plumbing supply store. Route the 1/4" copper tubing to suit your installation being sure not to kink the tubing. Purchase enough copper tubing length to allow a coil to be formed behind the unit for a "service loop" which will allow the appliance to be pulled out from the installation for servicing or cleaning (Figure 5). Connect the copper tubing to the "top side" of a cold water pipe to prevent the ice-maker from plugging with sediment.

A shutoff valve is recommended on the water supply line to ease servicing the appliance. NOTE: A SELF-PIERCING TYPE VALVE IS NOT RECOMMENDED as they are prone to clogging with sediment which will create pressure drop reducing the water supply to the unit.

Connect the copper tubing water supply to the water valve inlet with the compression nut fitting provided. Secure the water supply line to the back of the cabinet with the screw and strain relief clamp provided in the corner of the back panel (Figure 5).

Make certain all connections are watertight after installation. Form the tubing so that it will not vibrate against the cabinet body or kink when your appliance is moved in and out of position.

This ice machine is designed to make clear ice from the majority of water sources on a daily basis. If your results are unsatisfactory, your water may need to be filtered or treated. A water specialist can recommend proper water treatment.

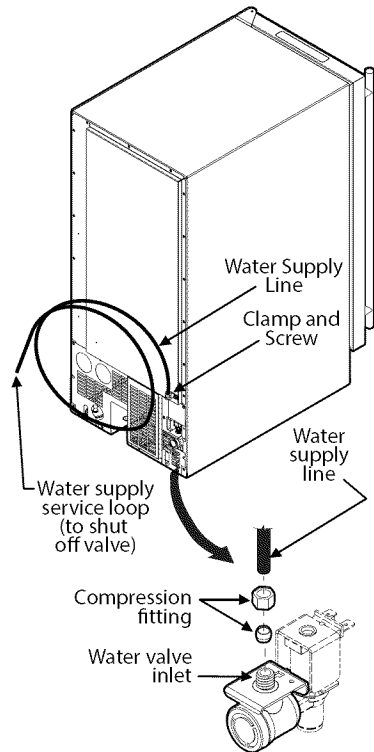

Figure 5 Back view of ice machine



NOTE

- The water line fitting is to be used with copper tubing only. Do not use with plastic tubing since it may crack or rupture with age.
- Do not use any thread sealers on this water line fitting.
- Reverse osmosis, (RO), water, softened water, and de-ionized water are not recommended as they will adversely affect the quality of the ice.

Once all connections have been made, plug in the power cord and gently push the unit into position. Allow at least 1-1/2 inches clearance behind the unit for electrical, water supply and drain connections.

Electrical Connection

A grounded 115 volt, 15 amp dedicated circuit is required.

This product is factory equipped with a power supply cord that has a three-pronged, grounded plug. It must be plugged into a mating grounding type receptacle in accordance with the National Electrical Code and applicable local codes and ordinances (Figure 6). If the circuit does not have a grounding type receptacle, it is the responsibility and obligation of the customer to provide the proper power supply. The third ground prong should not, under any circumstances, be cut or removed.

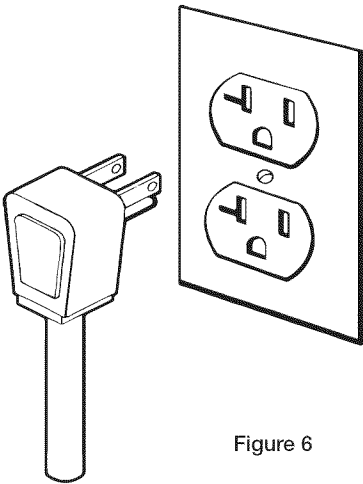

Figure 6



NOTE

Ground Fault Circuit Interrupters (GFCI) are prone to nuisance tripping which will cause the appliance to shut down. GFCI's are generally not used on circuits with power equipment that must run unattended for long periods of time, unless required to meet local building codes and ordinances.



WARNING

Electrical Shock Hazard

- Do not use an extension cord with this appliance. They can be hazardous and can degrade product performance.
- This appliance should not, under any circumstances, be installed to an ungrounded electrical supply.
- Do not remove the grounding prong from the power cord (Figure 7).
- Do not use an adapter (Figure 8).
- Do not splash or spray water from a hose on the appliance. Doing so may cause an electrical shock, which may result in severe injury or death.

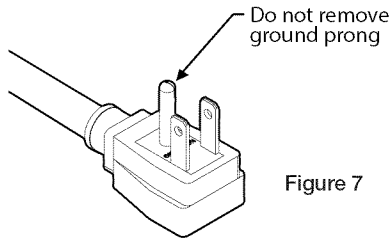

Figure 7

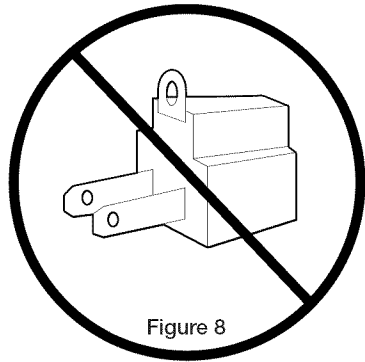

Figure 8



WARNING

Electrical Shock Hazard

Reasonable care and safe methods should be practiced. Do NOT work with energized electrical equipment in a wet area. Read and follow the installation instructions listed in this manual.

10 Installation

Leveling Legs

Adjustable legs at the front and rear corners of the appliance should be set so the unit is firmly positioned on the floor and level from side-to-side and front-to-back. The overall height of your appliance may be adjusted to higher (by turning the leveling leg out, counter clockwise) and lower (by turning the leveling leg in, clockwise) dimensions as shown in Table "A".

Table A

Models	Minimum Height	Maximum Height
UR15IM20RS	33 $\frac{5}{8}$ "	34 $\frac{3}{4}$ "
UL15IM20RS	(85.4 cm)	(88.3 cm)

To adjust the leveling legs, place the appliance on a solid surface and protect the floor beneath the legs to avoid scratching the floor. With the assistance of another person, lean the appliance back to access the front leveling legs. Raise or lower the legs to the required dimension by turning the legs. Repeat this process for the rear by tilting the appliance forward using caution. On a level surface check the appliance for levelness and adjust accordingly.

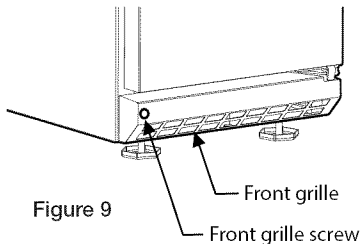

Leveling the unit

- 1 Use a level to check the levelness of the ice maker from front to back and from side to side (Figure 10).

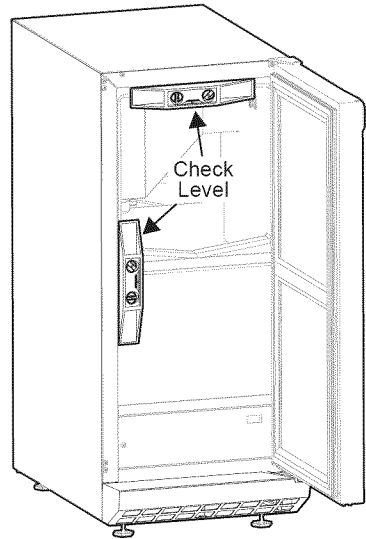

Figure 10

- 2 If the ice maker is not level, adjust the feet on the corners of the unit as necessary (Figure 11).

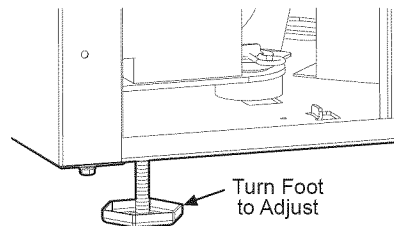

Figure 11

- 3 Check the levelness after each adjustment and repeat the previous steps until the unit is level.

Adjusting the Door

Your door is aligned at the factory before shipment. Occasional re-adjustment may be necessary, especially if an overlay panel is installed. The following procedure will correct for up to 1/4" alignment.

The door should never be flush with the top of the cabinet. Even when level, the top edge of the door will be 1/8" below the top of the cabinet (Figure 1).

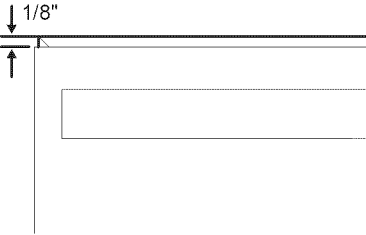

Figure 1

To adjust :

- 1 Compare the top edge of the door (opposite the hinges) to the top edge of the cabinet and note the type of adjustment (up or down) needed.
- 2 Remove the top hinge pivot pin with a 1/8" Allen wrench (Figure 2) and lift door off bottom hinge pin. Be careful not to lose door closers (Figure 3).
- 3 With door upside-down, loosen but do not remove the two hinge plate screws.

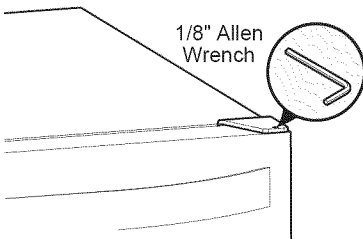

Figure 2

- 4 If door edge opposite the hinges needs to move up, move plate toward outside of door. If door edge needs to move down, move plate toward inside of door. Repeat until top edge of door is parallel with top of cabinet and tighten screws securely.
- 5 After adjustment is complete, remove the door closers from the bottom hinge, clean thoroughly and apply petroleum jelly to the mating surfaces of the closers (Figure 3). Be sure that bosses on closers align with holes in hinge and hinge plate. Mount door and install top hinge pivot pin.

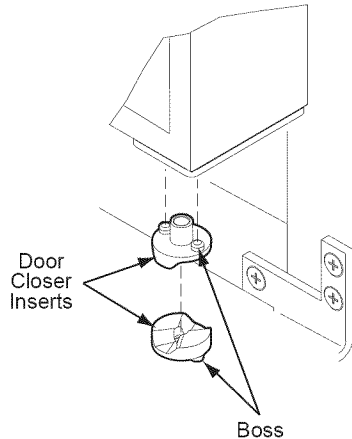

Figure 3

12 Operation of Ice Machine

Ice Making Process

Your ice machine is unique in how it forms ice with fractional freezing to form a slab of ice that is clear and has less mineral content than the water it is produced from. This is accomplished by running water over the cold evaporator plate (Figure 1) which gradually freezes the water to produce the ice slab. Pure water freezes first, leaving the dissolved minerals in the residual reservoir water to provide clear ice.

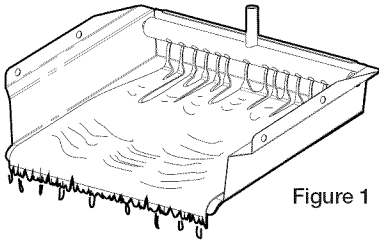

Figure 1

When the ice slab reaches the correct thickness, the ice sheet is released and slides onto the grid cutter (Figure 2). Here, the ice slab is cut into squares by the grid cutter's heated wires (Figure 3). The water containing the dissolved minerals is drained after each freezing cycle. Fresh water enters the machine for the next ice making cycle.

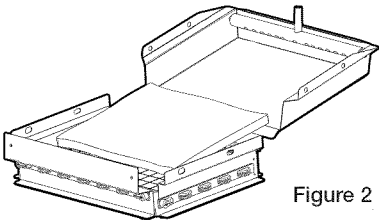

Figure 2

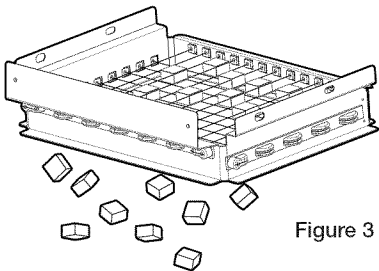

Figure 3

The ice machine will keep producing ice until the ice machine's bin is full and will restart automatically when ice needs to be replenished in the bin. The ice bin is not refrigerated, and some melting will occur. Allow your ice machine to run for 24-48 hours to accumulate ice in the ice machine's bin.

The bin level sensor is located in the ice bin, it senses when the ice supply is low or full and starts or stops the ice making process accordingly.



NOTE

If the water supply is turned off to the ice machine be sure to set the electronic control to the "OFF" position.

Ice Production

In normal mode the ice machine will produce about 35 pounds (15.9 kg) of clear ice in a 24 hour period when installed in a 70°F ambient temperature with a 70°F water supply. In "ECO" mode (Controls section) the energy consumption and the amount of ice produced in a 24 hour period will be reduced by approximately 23 percent.



NOTE

"Initial" ice production and ice accumulated in the storage bin will vary significantly. This is normal. During the first 24 hours of operation the unit will produce about 30 lbs. of ice at the above temperature conditions, but when starting with an empty ice storage bin, the storage bin may only accumulate about 18 lbs. of ice. By design, the ice storage bin is maintained at a temperature slightly above freezing to allow the stored ice to slowly melt, to preserve the clarity and assure a constant supply of fresh ice. As ice is accumulated in the bin, the ice production rate will overcome the ice melt and the storage bin will fill to capacity.

New Sounds

The ice machine will make sounds that are different than your household refrigerator. Because these sounds are new to you they may be of concern but are most likely normal. The ice production process will make noises that are not typical in a refrigeration product, ice falling onto hard surfaces, water cascading across the evaporator plate, and valves opening and closing. Following are some of the sounds that you may hear:

- A rattling noise which could be water flowing through the water line.
- A splashing sound when water is flowing over the evaporator plate and into the water reservoir.
- A "thud" when the ice slab is released from the evaporator plate and slides onto the grid cutter.
- A gurgling sound which is refrigerant flowing in the ice machine.
- An air noise from the condenser fan.

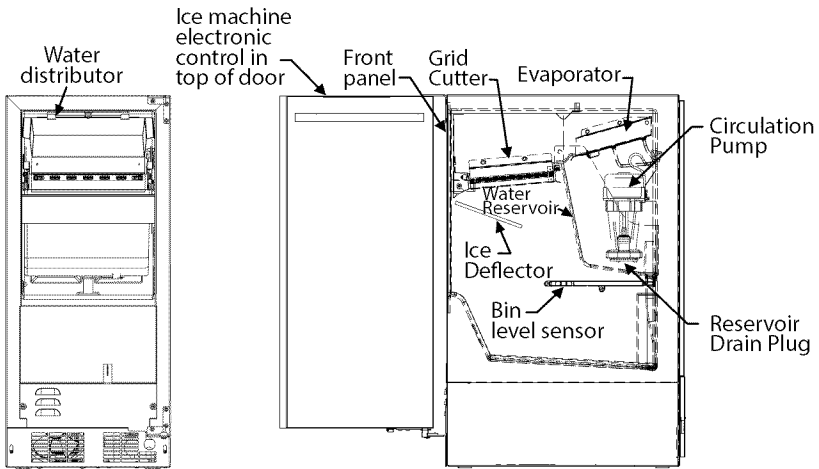

Figure 4

14 Built-In Installation/Start-Up

Installing a Built-In

Your Electrolux product has been designed for either free-standing or built-in installation. When built-in, your ice maker does not require additional air space for top, sides or rear. However, the front grille must NOT be obstructed.



NOTE

To ease unit installation and removal, the unit must be located to allow clearance for water, drain and electrical connections in the rear of the ice maker.

Built-In Cabinet Dimensions			
Model	Min. Cut-Out Dimensions		
	Width	Height	Depth
UR15IM20RS UL15IM20RS	14-15/16"	34"	24"



CAUTION

DO NOT install unit behind closed doors.

Initial Start-Up

Once installation and leveling is complete, the unit is ready for initial start-up and operation. All units are shipped with controls that are preset. No initial adjustments are required.



IMPORTANT

It is possible that dirt or scale will dislodge in the water line. Always throw away all ice cubes made during the first two to three hours of operation.

Plug into a 115 volt polarized and grounded electrical outlet.

Open the water supply valve at the main water source.

USING YOUR ELECTRONIC CONTROL

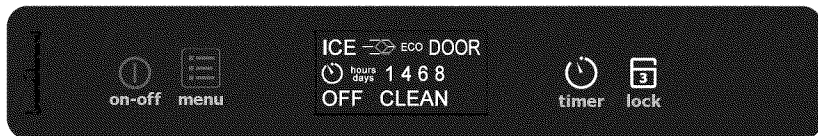

Display icons:



"on-off" icon: used for turning the appliance on and off and confirming selections.



"menu" icon: used to access optional functions in the user interface.



"timer" icon: used to enter the Delay start/vacation mode.



"lock" icon: used to lock out functions in the user interface.

Display area text:

ICE

Signifies the appliance is on and producing ice.

ECO

Signifies the appliance is in economical ice production mode.

OFF

Signifies the appliance is off

DOOR

Signifies a door ajar alarm condition.

CLEAN

Cleaning is recommended or the appliance is in the clean mode.



NOTE

The control display is covered with a clear plastic film. This film may be removed by carefully lifting at a corner.

Starting your clear ice machine:

Plug the ice machine into a 115 **ICE** volt wall outlet. Your appliance is shipped from the factory in the "ICE" mode and will automatically begin making ice as soon as power is supplied to the unit. If the appliance does not start, confirm the wall outlet has power, and the control is in the "ICE" mode (Options section). Do not start the ice machine in "ECO" mode. "ECO" mode should only be used after there is a full bin of ice.



CAUTION

Turning the ice machine "OFF" will only terminate the ice production, it does not remove power from the appliance. Always unplug the power cord from the wall outlet before servicing the unit.

Turning your ice machine On and Off:

If your appliance is on, "ICE" will be displayed. To turn the appliance off, push and hold the "ON/OFF" icon for 3 seconds. The display will show "OFF". The drain pump and the interior light will still be functioning during the OFF mode. To turn the appliance back on, press and hold the "ON/OFF" icon for 3 seconds, the display will show "ICE".



NOTE

If in delay mode, the delay function must first be cancelled to enable the ON/OFF function.

Control Lock:

The user interface can be locked to avoid unintentional changes from things like cleaning. To lock the appliance, push and hold the "LOCK" icon for 5 seconds. The "LOCK" icon will flash 3 times, then change to steady back-lit. To unlock the user interface, press and hold the "LOCK" icon for 5 seconds, and the back-light will turn off.



NOTE

The "LOCK" icon is the only active key in this mode. If other icons are pressed while in the lock mode the "LOCK" icon will flash 3 times, and an audible tone will sound, to remind the user the appliance is in the lock mode.

Delay start/Vacation mode:

Your ice machine is equipped with a delay start function. This feature can be used to temporarily shut the appliance off for 1, 4, 6, or 8 hours or days. Upon completion of the selected delay period, the appliance will resume operation. This is ideal for temporarily stopping ice machine noises or to save water and electricity if you are away from home but want fresh ice upon your return.

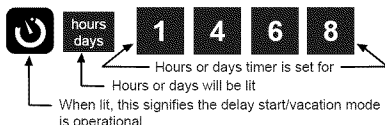

To enter the delay start mode, press the "CLOCK" icon while the appliance is in "ICE" mode. This will delay the next harvest by the time displayed. Each additional press of the "CLOCK" icon will add **hours days** time, from 1, 4, 6, or 8 hours, to 1, 4, 6, or 8 days. The next press after 8 **1 4 6 8** days will leave delay set mode.

After the desired time has been determined, press the "ON/OFF" icon for 2 seconds to accept, your unit will shut off and a clock icon and your selected time will be displayed. When the selected time has elapsed, normal ice production will resume.

To cancel the delayed start, press and hold the "ON/OFF" icon until the appliance enters OFF, then press and hold the "ON/OFF" icon again until the appliance enters "ICE" mode. You can also cancel by pressing and holding the "CLOCK" icon until it reverts back to "ICE" mode.

Clean reminder:

A "CLEAN" reminder will occur every 6 months to remind you that it may be time to clean your appliance. Over time mineral build up on the cold evaporator plate can occur which can adversely affect the quality of your ice. This build-up is dependent on your water source. Normal ice production will continue while the "CLEAN" reminder is displayed. You may clear the "CLEAN" reminder at any time by momentarily pressing the "ON/OFF" icon. When reset, the "CLEAN" reminder will reset and not occur for another 6 months. If you choose to clean the appliance at this time, see the Options Menu section.

16 Built-In Installation/Start-Up

Door ajar alarm:

If the door is open, or not closed properly for 5 minutes the "DOOR" indicator will illuminate and flash and an audible tone will sound. This alarm condition can be reset by closing the door or momentarily pressing the "ON/OFF" icon, (i.e.-if you are cleaning the storage compartment, etc.). The alarm will recur in 5 minutes if the alarm condition persists.

If the door is intentionally left open for long periods, the alarm can be disabled by turning the unit off.

Options menu

Normal and ECO mode:

Your ice machine comes with an optional "ECO" mode. While in this mode ice production will slow and the appliance will use less water and electricity. "ECO" mode should only be used after there is a full bin of ice. To enter "ECO" mode do the following:

- Press the "MENU" icon twice and the green "ECO" will flash.
- Press and hold the "ON/OFF" icon until the green "ECO" stops flashing and remains illuminated.
- To return to the standard operating rate press the "MENU" icon twice, the ECO will turn off and the "ICE" will be flashing. Press and hold the "ON/OFF" icon until the "ICE" stops flashing and remains illuminated.

Clean mode:

To clean your ice machine you will need to purchase a "nickel safe" ice maker cleaner. Cleaner is available at most appliance retailers or through the cleaners website. Several recommended cleaners are listed below:

- Kirby's Certified ice machine cleaner. 100% nickel safe.
- Nu-Calgon nickel safe ice machine cleaner.
- Franklin Machine Products Nickel safe ice machine cleaner.

Once you have your cleaner:

Turn the ice machine off by pressing and holding the "ON/OFF" icon for 3 seconds. "OFF" will be displayed on the control.

Remove the grid cutter cover (Figure 1) by pulling the cover off of the three rubber isolation mounts.

Remove all ice from the ice bin (Figure 1).

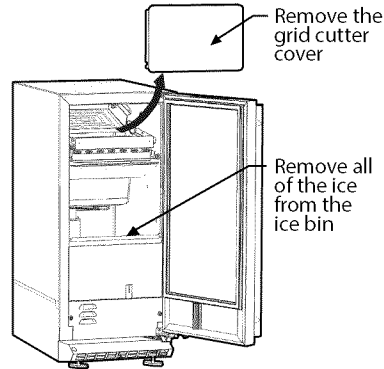

Figure 1

Allow all of the ice to fall from the evaporator plate and remove any ice from the grid cutter. If there is ice embedded in the grid cutter wires, wait for it to melt and fall out. Do not try to remove ice that is embedded in the grid cutter wires as that may break the wires (Figures 2 and 3).

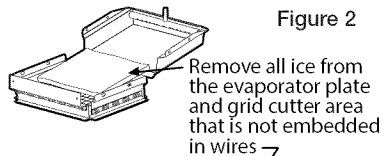

Figure 2

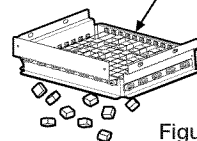

Figure 3



CAUTION

Forcing ice through the grid cutter will break the grid cutter wires.

Drain the water from the water reservoir, by removing the black plug from the bottom of the fresh water reservoir (Figure 4). After the water is drained replace the plug in the bottom of the reservoir and firmly press into place (Figure 4b).

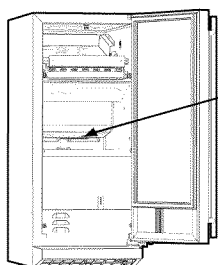

Figure 4

Remove the black reservoir drain plug from the bottom of the reservoir.

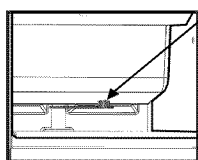

Figure 4b

Refer to your cleaning solution instructions to determine the proper amount of cleaning solution to add based on 3 quarts (2.8 liters) of water. Pour the cleaning solution between the evaporator plate and the grid cutter so it flows down into the fresh water reservoir (Figure 5).

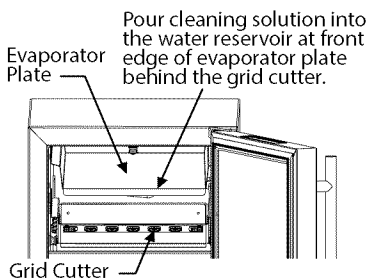

Figure 5

The plastic splash shield can be removed by lifting off hanger brackets to improve access (Figure 6).

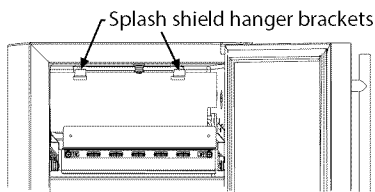

Figure 6

Turn the ice machine back on by pressing and holding the "ON/OFF" icon for 3 seconds. The display will indicate "ICE" mode. Press and hold the "MENU" icon until a flashing "CLEAN" is displayed. Press the "ON/OFF" icon until "CLEAN" stops flashing. Your ice machine will now enter the clean cycle.



ICE



CLEAN

The clean and rinse cycle will take about 49 minutes.

After the clean cycle is complete the ice machine will return to the "OFF" position.

OFF

After the cleaning cycle is completed, verify that all build-up has been removed. If not repeat the clean cycle procedure.

Optional: After the cleaning cycle has been completed, you may wash the interior with a mild detergent / dish soap or a solution of two tablespoons of baking soda and one quart of water. Rinse with clean water.

Replace the splash shield (if removed) and grid cutter cover.

Your ice machine is now ready to restart. Press and hold the "ON/OFF" icon for 3 seconds until "ICE" is displayed.

ICE



NOTE

After cleaning discard all of the ice produced within the first 3 hours of operation.

Special Considerations

- For best performance, keep the unit out of direct sunlight.
- Turn the unit OFF and dispose of any ice cubes if the unit will not be used for 5 days or more. Prop door open to allow for air circulation and prevent mold and mildew.
- If the ambient temperature is expected to drop below 45°F (7°C), drain all water from the unit to prevent freezing damage not covered by the warranty.
- High ambient temperatures, 100°F (38°C) or higher, will reduce the unit's ability to reach low temperatures and may also reduce the ice production rate.

Maintaining and Cleaning Your Ice Maker

Periodic cleaning and proper maintenance will ensure efficiency, top performance, and long life. The maintenance intervals listed are based on normal conditions. You may want to shorten the intervals if you have pets or other special considerations.

Exterior Cleaning - As Required

The door, grille and cabinet may be cleaned with a mild detergent and warm water solution. Do not use solvent based or abrasive cleaners.

Use a soft sponge and rinse with clean water. Wipe with a soft, clean towel to prevent water spotting.

Stainless Steel Models

- Stainless steel may discolor when exposed to chlorine, pool chemicals, salt water or cleaners with bleach.
- Keep your stainless unit looking new by cleaning with a high quality, all-in-one stainless steel cleaner/polish on a monthly basis. Frequent cleaning will remove surface contamination that could lead to staining and rust. Some installations will require cleaning on a weekly basis.
- DO NOT CLEAN WITH STEEL WOOL PADS.
- DO NOT USE CLEANERS THAT ARE NOT SPECIFICALLY INTENDED FOR STAINLESS STEEL (this includes glass, tile and counter cleansers).

- If any surface discolors or rusting appears, clean it quickly with Bon-Ami or Barkeepers Friend Cleanser and a non-abrasive cloth. Always clean in the direction of the grain. Always finish this process with a high quality, all-in-one stainless steel cleaner/polish to prevent further problems.
- USE OF ABRASIVE PADS SUCH AS SCOTCHBRITE WILL CAUSE THE GRAINING IN THE STAINLESS TO BECOME BLURRED.
- Rust that is allowed to linger can penetrate



CAUTION

Stainless steel models exposed to chlorine and moisture, such as areas with spas or swimming pools, may have some discoloration of the stainless steel. Follow exterior cleaning instructions.

Interior Cleaning - As Required

- 1 Disconnect power to the ice maker.
- 2 Open the door and remove any ice from the storage bin.
- 3 Wipe down the interior and storage bin with a solution of non-abrasive mild soap or detergent and warm water. Rinse with clean water.
- 4 Sanitize the bin with a solution of 1 tablespoon of bleach in 1 gallon of warm water. Rinse thoroughly with clean water.
- 5 Check that all drain connections are in place.



CAUTION

- DO NOT use solvent cleaning agents or abrasives on the interior. These cleansers may transmit taste to the ice cubes, or damage or discolor the interior.
- DO NOT use any cleaner on the evaporator plate other than Ice Machine Cleaner. Other cleaners may affect ice quality, or cause damage to the unit that is not covered under warranty.

- 6 Reconnect power to the unit.

Condenser Cleaning — Every 3 Months

To maintain operational efficiency, clean the condenser every three months (depending on environmental conditions, more or less frequent cleaning may be necessary).



WARNING

Disconnect electric power to the ice maker before cleaning the condenser.

To remove and replace the grille for access to the condenser, follow this procedure (Figure 1):

- 1 Loosen the two Phillips head screws, one at each end of the grill. It is not necessary to remove them.
- 2 With the door open, raise up on the end of the grille opposite the hinges and pull toward you to remove the screw from the keyhole slot in the grille.
- 3 Pull the grille to the side to remove the grille.

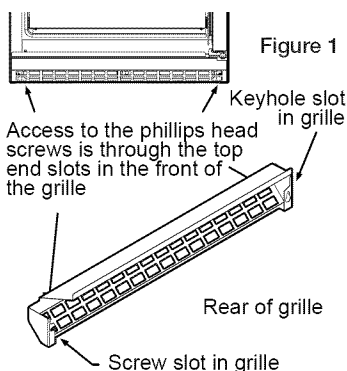

WARNING

DO NOT touch the condenser. The ends of the wires are sharp and can also be easily damaged.



CAUTION

DO NOT use any type of cleaner on the condenser unit.

- 4 Clean the condenser coil using a brush with a "combing" action or a vacuum cleaner. Do not touch the condenser coil.
- 5 Clean the grille, then position the grille over the screws in the cabinet.
- 6 Tighten the grille screws.

Automatic Cleaning — Every 6 Months

To maintain operational efficiency, clean the unit every six months (depending on water conditions more or less frequent cleaning may be necessary). If the ice maker requires more frequent cleaning, consult a qualified plumber to test the water quality and recommend appropriate treatment.



WARNING

Wear rubber gloves and safety goggles and/or face shield when handling Ice Machine Cleaner.



CAUTION

It is a violation of Federal law to use this solution in a manner inconsistent with its labeling.

Read and understand all labels printed on the package before use.

Ice machine cleaner is used to remove lime scale and other mineral deposits. Refer to the following steps for mineral deposit removal.



CAUTION

Never use anything to force ice from the evaporator. Damage may result.



IMPORTANT

- Discard all ice produced during the first 3 hours of operation after cleaning.
- If power gets interrupted during the self-clean cycle, it will be necessary to repeat the complete cleaning cycle after power is restored.

PREPARING THE ICE MACHINE FOR STORAGE

If the ice machine is moved, not used for an extended period of time, or will be in an area that will be near freezing temperatures, it is necessary to remove any remaining water in the ice-making system.



CAUTION

This ice machine must have all water drained and removed to prevent ice machine damage as well as possible water damage to the surrounding area in freezing conditions. These damages are not covered under warranty.



CAUTION

Do not use any type of anti-freeze or other solution as a substitution for properly draining the ice machine.

Clean the Ice Machine

Cleaning the ice machine will help prevent mold and mildew growth as well as sanitize the ice machine for storage or when it is put back into service.



WARNING

Electrical Shock Hazard. Risk of electrical shock or personal injury could occur due to moving components, if machine compartment access cover is removed before unplugging the ice machine.

Draining and Removing Water from the Ice-Making System with a Gravity Drain.

1. Turn off the water supply to the ice machine.
2. Disconnect the water supply fitting at the inlet of the water valve (Figure 2).

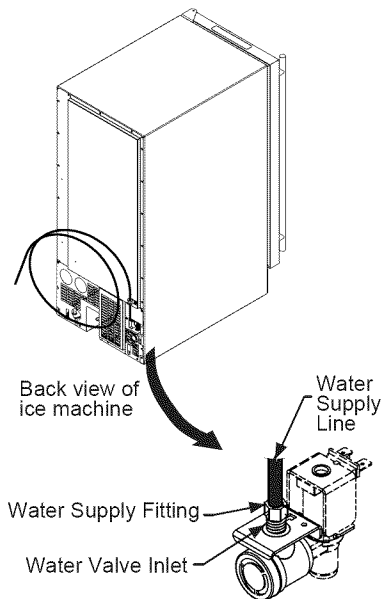

Figure 2

3. Change the electronic control to the "CLEAN" position for approximately one minute. This will energize and open the water valve and remove most of the water from the water valve and the water valve's outlet water line to the reservoir.
4. Change the electronic control to the "OFF" position. This will energize and open the drain valve to drain the reservoir and the ice machine drain system.
5. Unplug the ice machine from the electrical outlet.

- Remove the access cover from the rear of the ice machine (Figure 3).

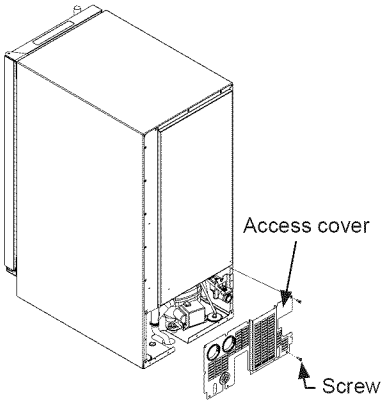

Figure 3

- Disconnect the water valve's outlet water line to the reservoir and drain the remaining water left in the water line trap area (Figure 4).

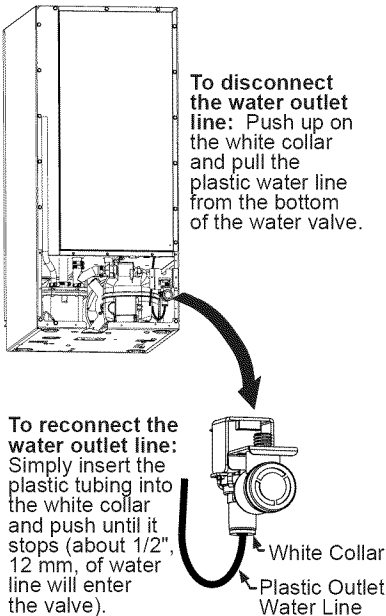

Figure 4

- Reconnect the water valve outlet water line (Figure 4).
- Reinstall the ice machine's access cover.
- Clean and dry the ice machine's storage bin.
- Prop the door open for air circulation to prevent mold and mildew.
- Leave the water supply line disconnected or reconnect the supply line and leave it shut off. Do NOT turn the water on and allow water to enter back into the water valve.

Draining Water for Factory Installed Drain Pump Applications

Follow steps 1 through 12 for the gravity drain then do the following:

- Install the winterization plug in the water drain hole inside the ice bin (Figure 5).

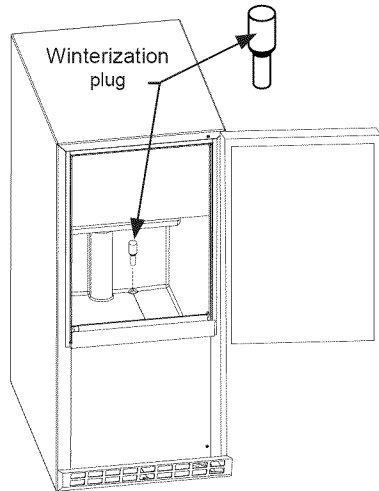

Figure 5

22 Maintenance

14. Remove the top clamp from the vent tube, for easier access for the air hose.
15. Apply air pressure (approximately 10 psi) to the end of the vent tube which will purge the remainder of the water from the drain pump and the drain line (Figure 6).
16. Reinstall the vent tube and clamp to the back of the ice machine and remove the winterization plug from the ice bin and save it for future use.

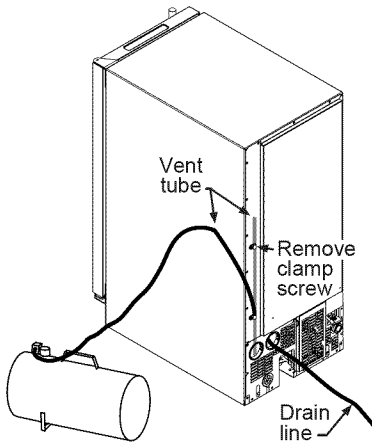

Figure 6

To Restart the Ice Machine

1. Reconnect or turn on the water supply line.
2. Reconnect drain tubing if removed.
3. Plug in the power cord to a wall outlet and turn the ice machine on.
4. Check the water inlet, drain lines, and fittings for any water leaks.
5. Check drain pump (if equipped) operation by pouring approximately two quarts of water into the ice storage bin. The drain pump should activate and discharge water (refer to Drain Pump section). Check for water leaks at all hose connections.

DRAIN PUMP REMOVAL INSTRUCTIONS (FOR SERVICE ONLY)

1. Unplug the ice machine from the electrical supply and remove the rear access cover from the ice machine.
2. Unscrew the leveling leg in the back corner until the end of the threaded portion is flush with the threaded nut insert in the base (Figure 8).
3. Unscrew the 3 hose clamps and remove the 3 hoses from the front of the drain pump and remove retaining brackets (Figure 8).
4. Rotate the drain pump and remove from the ice machine (Figure 7). It may be necessary to disconnect the ground wire connection in the back flange of the cabinet (Figure 8).

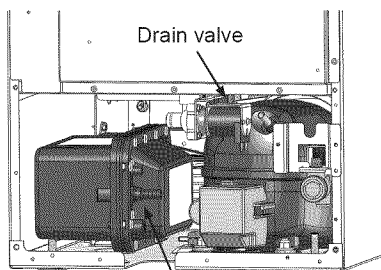

Rotate drain pump and remove from back of ice machine.

Figure 7

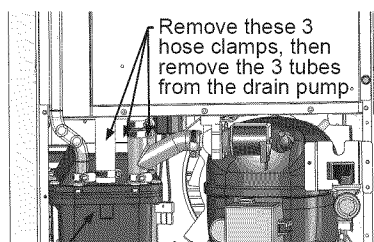

Unscrew the leveling leg so the end of the threads is flush with the top of the nut inset.

Drain pump ground wire connection

Figure 8

5. Disconnect the ice machine power cord from the drain pump (Figure 9).

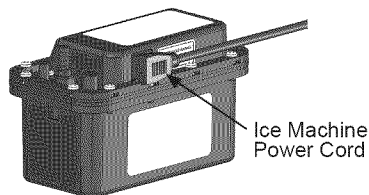

Figure 9

6. Drain the water in the drain pump's reservoir by turning the pump upside down and allowing water to drain through the pump's inlet and vent tube fittings.
7. Installation of drain pump is reverse of this procedure.

Additional issues to be inspected by the installer upon service replacement:

1. The drain pump must be level.
2. No pinched water lines.
3. No interference with electrical cords or wiring.
4. The drain pump should not set on any obstacles, wiring, etc.
5. Secure all hose clamps leading to and from the drain pump.
6. Ensure that the vent tube height is adequate - 18 inch minimum.
7. Ensure that drain height is adequate - maximum of 8 foot.
8. Ensure that drain length is adequate - maximum of 20 foot.
9. Checked for water leaks after installation of the drain pump.
10. Check for vibrations caused by improper installation.
11. Ensure that there is no interference with back access cover.
12. Ensure that the hole grommets are in place at each location so that any vent or drain tubes do not rub on any sharp surfaces.

24 Troubleshooting

Before You call For Service

If the unit appears to be malfunctioning, read through Normal Operation first. If the problem persists, check the Troubleshooting Guide. Locate the problem in the guide and refer to the cause and its remedy before calling for service. The problem could be something very simple which can be solved without a service call.



DANGER

ELECTROCUTION HAZARD

NEVER attempt to repair or perform maintenance on the unit until the main electrical power has been disconnected.

Troubleshooting Guide

Problem	Possible Cause	Remedy
Unit does not operate.	<ul style="list-style-type: none">• No electrical power to the unit.• Cycle selector switch set improperly.• Is the ice machine's power cord plugged in?• Is the electronic control showing the "ICE" position?• Is a fuse blown or a circuit breaker been tripped?• Is the temperature of the room cooler than it normally is?• Is there a drain pump in the ice machine?	<ul style="list-style-type: none">• Make sure power cord is plugged in. Check for blown fuse or tripped circuit breaker.• Make sure cycle selector switch is set to ICE/ON.• Plug the power cord into a grounded 3 prong outlet.• Check the control to be sure it is in the "ICE" position.• Replace a blown fuse or reset a tripped circuit breaker.• The minimum room temperature is 55°F (13°C). The bin thermistor may be sensing the room temperature and shut off before the bin is full of ice. If the room temperature remains low the ice machine may not restart.• The drain pump is designed to temporarily shut the unit off when large quantities of water create a high-limit condition. Wait a few minutes as the drain pump will continue to operate to dispose of the excess water. If there is still water in the ice bin check the drain pump vent line and drain line for obstructions or kinking.
Unit runs but no ice is produced.	<ul style="list-style-type: none">• No water being supplied to the unit.	<ul style="list-style-type: none">• Check to see that water is connected and turned on to the unit and that ambient temperature does not exceed 100°F.

Problem	Possible Cause	Remedy
Unit runs but produces very little ice.	<ul style="list-style-type: none"> • Dirty condenser coils. • High air temperature around unit. • Scale and mineral buildup in unit. • Inadequate airflow at the front of the unit. • Missing or loose reservoir drain plug. • Cleaning cycle recently performed. 	<ul style="list-style-type: none"> • Clean the condenser. See Maintenance. • Surrounding air temperature of over 90°F (32°C). Low ice production at high temperatures is normal. • Clean unit. See Maintenance. • Remove items blocking airflow. • Make sure reservoir drain plug is securely in place. • Allow unit to reach the set temperature to produce ice normally.
Ice is slow to release or does not release from the evaporator.	<ul style="list-style-type: none"> • Ice-making system is dirty. • Unit is not level. 	<ul style="list-style-type: none"> • Run unit through automatic clean cycle. See Maintenance. • See Leveling the Unit.
Poor ice quality (soft or unclear).	<ul style="list-style-type: none"> • Poor incoming water quality. • Ice-making system is dirty. 	<ul style="list-style-type: none"> • Consult a qualified plumber to test the water quality and recommend appropriate treatment. • Run unit through automatic clean cycle. See Maintenance.
Unit produces shallow or incomplete cubes, or the ice fill pattern on the evaporator is incomplete.	<ul style="list-style-type: none"> • Low water level. • Hot incoming water. • Incorrect incoming water pressure. • Unit is not level. 	<ul style="list-style-type: none"> • Check to see that overflow tube is fully seated. • Connect the unit to a cold water supply. See Installation. • Water pressure must be 20 - 120 ps. • See Leveling the Unit.
Water leaking from under the unit.	<ul style="list-style-type: none"> • Supply line leaking. • Fill tube leaking. • Bin drain leaking. • Unit not level 	<ul style="list-style-type: none"> • Check to see that the water inlet line is attached to inlet valve properly. See Connecting the Water Supply. • Check connection at water valve outlet. • Check integrity of bin drain hose and clamp. • See "Leveling the Unit" section.
Ice storage bin full of water.	<ul style="list-style-type: none"> • Obstructed drain. 	<ul style="list-style-type: none"> • Check to see that storage bin drain opening is free from obstruction and debris. Check pump and drain line.

26 Troubleshooting

Problem	Possible Cause	Remedy
The ice machine is noisy	<ul style="list-style-type: none"> • Do you hear water being circulated in the ice machine? • Is there a “whooshing” sound? • Is there an ice slab caught between the evaporator plate and the grid cutter? 	<ul style="list-style-type: none"> • This is a normal sound as water is added once every ice making cycle. • Make sure water is getting to the ice machine. Also check to make sure the drain plug is fully seated in the water reservoir. • First check to see if the ice machine is level. If the ice machine is level run a cleaning cycle.
Little or no ice production from the ice machine	<ul style="list-style-type: none"> • Is the electronic control set to the “ICE” position? • Is water getting to the ice machine? • Has the ice machine just been started? • Is the reservoir drain plug in place? • Is the water distributor tube restricted? • Is the condenser fan air flow restricted? • Is the room and/or water temperature too warm? • Is there scale build up in the ice machine? 	<ul style="list-style-type: none"> • Check the control to be sure it is in the “ICE” position. • Make sure nothing is restricting the water supply such as a closed water valve or a blown fuse or tripped circuit breaker, or a kinked supply line, or low water pressure. • A typical ice production cycle can take up to 1½ hours. Initial start up cycles can take longer. Check the ice machine after 24 hours for ice accumulation in the bin. • Check that the reservoir drain plug is properly seated. • Run a cleaning cycle to clean the ice machine. Also check any filters to make sure they are not restricted. • Make sure the grille in the front of the ice machine is open for proper air circulation. • Move the ice machine to an area where the ambient temperature is below 90°F (32°C). The ice machine should not be placed next to a heat source such as an oven. Check the cold water connection. • If there is scale build up on the evaporator, the ice machine needs to be cleaned. See “Cleaning the Ice machine”.
Odor, grey color, or off taste in the ice	<ul style="list-style-type: none"> • Is there mineral scale build up on the evaporator plate? • Is there a high mineral content in the water? • Are food items being stored in the ice bin? 	<ul style="list-style-type: none"> • The ice machine needs cleaning. See “Cleaning the Ice Machine”. • The water may need to be filtered. • Remove food from the ice bin.

Problem	Possible Cause	Remedy
Clumps of ice	<ul style="list-style-type: none"> • Are there clumps of ice in the bin? 	<ul style="list-style-type: none"> • If the ice isn't used on a regular basis it will melt and form into clumps. Break up the ice clumps with the ice scoop.
Ice cubes are too big or too small	<ul style="list-style-type: none"> • Is there low ice consumption? • Is the ice slab releasing? • Is the distributor tube restricted? 	<ul style="list-style-type: none"> • Ice is slowly melting in the ice bin which will affect the size of the cubes. This is normal. When the ice bin needs to be replenished, cubes will return to the regular size. • Clean the evaporator. See "Cleaning the Ice Machine". • Check the water line to the ice machine to make sure there are no restrictions or kinks in the line. Check all filters to make sure they are not restricted. Check that the water flows evenly out of the distributor tube, if not, clean the ice machine. See "Cleaning the Ice Machine".
Plumbing Problems	<ul style="list-style-type: none"> • Is the drain hose aligned over the drain? • Is the ice machine draining properly? 	<ul style="list-style-type: none"> • Move the ice machine to align the drain. • Check that there are no kinks or restrictions in the drain lines; this can cause water to back up in the ice bin. Check that foreign material is not blocking the ice bin drain located at the right rear corner of the ice bin. Check the drain pump discharge and vent line or any restrictions or kinks. Check that the drain pump is level.

28 Troubleshooting

Troubleshooting the Drain Pump

If the drain pump reservoir (not the ice machine bin) reaches overflow condition, the power to the ice machine will be shut off.

If the ice machine is not working, check the following:

- Make sure there is power at the receptacle.
- Make sure the ice machine is turned on.
- Make sure the ice bin is not full.
- Then check the drain pump.

The pump does not run:

- Make sure the pump is plugged in and there is power to the receptacle.
- Check the inlet to the drain pump for debris and clean as needed. Remove clamps and inlet tube from drain pump to check for and remove debris.
- Make certain the vent line is free of kinks/sharp bends or restrictions.
- Make certain there is enough water to activate the drain pump. It will take at least one (1) quart (.95 liters) of water to activate the drain pump.

The pump runs, but no water is pumped out:

- Check that the vent is clear and free of restrictions.
- Check the discharge line to make certain there are no restrictions.
- Make sure that the discharge tubing has not exceeded the maximum lift of eight (8) feet (2.44 meters) and the horizontal run is not greater than twenty (20) feet (6.1 meters).

The pump runs and then quickly turns off repeatedly:

- Check to make certain the drain pump is level.
- Check that the vent is clear and free of restrictions.

The ice machine is running but not producing ice:

- Check to make sure water is not backing up in the ice bin.

If Service is required

If the need for service arises, contact the dealer from whom the unit was purchased. State the Model Number and Serial Number and explain the problem. The Model and Serial Number plate is located inside the unit at the upper right hand corner.

If you do not know the name of the selling dealer or local service company, you can check online at www.electroluxappliances.com, or call 877-435-3287.

Major Appliance Warranty Information

Your appliance is covered by a one year limited warranty. For one year from your original date of purchase, Electrolux will repair or replace any parts of this appliance that prove to be defective in materials or workmanship when such appliance is installed, used, and maintained in accordance with the provided instructions. In addition, the cabinet liner and sealed refrigeration system (compressor, condenser, evaporator, dryer or tubing) of your appliance is covered by a two through five year limited warranty. During the 2nd through 5th years from your original date of purchase, Electrolux will repair or replace any parts in the cabinet liner and sealed refrigeration system which prove to be defective in materials or workmanship when such appliance is installed, used, and maintained in accordance with the provided instructions.

Exclusions

This warranty does not cover the following:

1. Products with original serial numbers that have been removed, altered or cannot be readily determined.
2. Product that has been transferred from its original owner to another party or removed outside the USA or Canada.
3. Rust on the interior or exterior of the unit.
4. Products purchased "as-is" are not covered by this warranty.
5. Food loss due to any refrigerator or freezer failures.
6. Products used in a commercial setting.
7. Service calls which do not involve malfunction or defects in materials or workmanship, or for appliances not in ordinary household use or used other than in accordance with the provided instructions.
8. Service calls to correct the installation of your appliance or to instruct you how to use your appliance.
9. Expenses for making the appliance accessible for servicing, such as removal of trim, cupboards, shelves, etc., which are not a part of the appliance when it is shipped from the factory.
10. Service calls to repair or replace appliance light bulbs, air filters, water filters, other consumables, or knobs, handles, or other cosmetic parts.
11. Pickup and delivery costs; your appliance is designed to be repaired in the home.
12. Surcharges including, but not limited to, any after hour, weekend, or holiday service calls, tolls, ferry trip charges, or mileage expense for service calls to remote areas, including the state of Alaska.
13. Damages to the finish of appliance or home incurred during transportation or installation, including but not limited to floors, cabinets, walls, etc.
14. Damages caused by: services performed by unauthorized service companies; use of parts other than genuine Electrolux parts or parts obtained from persons other than authorized service companies; or external causes such as abuse, misuse, inadequate power supply, accidents, fires, or acts of God.

DISCLAIMER OF IMPLIED WARRANTIES; LIMITATION OF REMEDIES

CUSTOMER'S SOLE AND EXCLUSIVE REMEDY UNDER THIS LIMITED WARRANTY SHALL BE REPAIR OR REPLACEMENT AS PROVIDED HEREIN. CLAIMS BASED ON IMPLIED WARRANTIES, INCLUDING WARRANTIES OF MERCHANTABILITY OR FITNESS FOR A PARTICULAR PURPOSE, ARE LIMITED TO ONE YEAR OR THE SHORTEST PERIOD ALLOWED BY LAW, BUT NOT LESS THAN ONE YEAR. ELECTROLUX SHALL NOT BE LIABLE FOR CONSEQUENTIAL OR INCIDENTAL DAMAGES SUCH AS PROPERTY DAMAGE AND INCIDENTAL EXPENSES RESULTING FROM ANY BREACH OF THIS WRITTEN LIMITED WARRANTY OR ANY IMPLIED WARRANTY. SOME STATES AND PROVINCES DO NOT ALLOW THE EXCLUSION OR LIMITATION OF INCIDENTAL OR CONSEQUENTIAL DAMAGES, OR LIMITATIONS ON THE DURATION OF IMPLIED WARRANTIES, SO THESE LIMITATIONS OR EXCLUSIONS MAY NOT APPLY TO YOU. THIS WRITTEN WARRANTY GIVES YOU SPECIFIC LEGAL RIGHTS. YOU MAY ALSO HAVE OTHER RIGHTS THAT VARY FROM STATE TO STATE.

If You Need Service

Keep your receipt, delivery slip, or some other appropriate payment record to establish the warranty period should service be required. If service is performed, it is in your best interest to obtain and keep all receipts. Service under this warranty must be obtained by contacting Electrolux at the addresses or phone numbers below.

This warranty only applies in the USA, Puerto Rico and Canada. In the USA and Puerto Rico, your appliance is warranted by Electrolux Major Appliances North America, a division of Electrolux Home Products, Inc. In Canada, your appliance is warranted by Electrolux Canada Corp. Electrolux authorizes no person to change or add to any obligations under this warranty. Obligations for service and parts under this warranty must be performed by Electrolux or an authorized service company. Product features or specifications as described or illustrated are subject to change without notice.

USA
1-877-435-3287
Electrolux Major Appliances North America
10200 David Taylor Drive
Charlotte, NC 28262

Canada
1-800-265-8352
Electrolux Canada Corp.
5855 Terry Fox Way
Mississauga, Ontario,
Canada L5V 3E4