

CROSLEY

All about the

Use & Care

of your Refrigerator

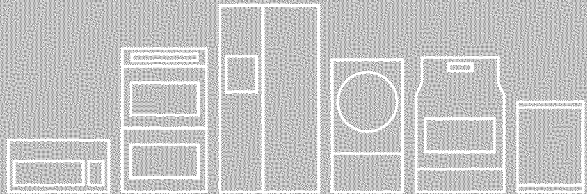

TABLE OF CONTENTS

Wecome & Congratulations	2	Ice Service.....	14
Important Safety Instructions.....	3	Controls.....	15
Features At A Glance	5	Optional Features	17
Installation	6	Normal Operating Sounds and Sights.....	20
Door Removal Instructions.....	8	Care and Cleaning	21
Handle Installation	10	Before you Call.....	22
Connecting Water Supply.....	12	Major Appliance Warranty	24

WELCOME & CONGRATULATIONS

Congratulations on your purchase of a new refrigerator! We here at Crosley Corporation are very proud of our product and we are completely committed to providing you with the best service possible. Your satisfaction is our #1 priority.

Please read this Use & Care Manual very carefully. It contains valuable information on how to properly maintain your new refrigerator.

We know you'll enjoy your new refrigerator and Thank You for choosing our product. We hope you consider us for future purchases.

Please Read and Save these Instructions

This Use & Care Manual provides specific operating instructions for your model. Use your refrigerator only as instructed in this manual. These instructions are not meant to cover every possible condition and situation that may occur. Common sense and caution must be practiced when installing, operating and maintaining any appliance.

Please record your model and serial numbers below for future reference. This information is found on the serial plate located inside the refrigerator compartment.

Model Number: _____

Serial Number: _____

Purchase Date: _____

For product information contact:

336-761-1212

Crosley Corporation

111 Cloverleaf Dr.

Winston-Salem, NC 27103

www.crosley.com

Please attach sales receipt here for future reference.

NOTE

Use only soap and water to clean serial plate.

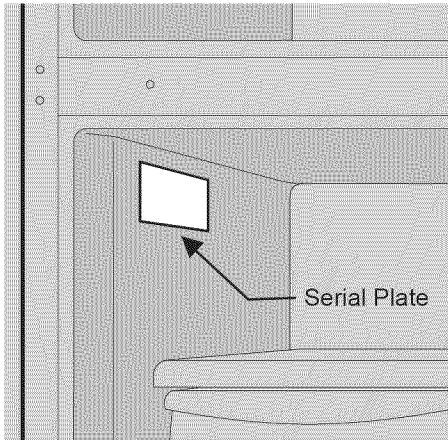

Please complete and mail in the Product Registration Card included with your refrigerator.

IMPORTANT SAFETY INSTRUCTIONS



WARNING

Please read all instructions before using this refrigerator.

For your Safety

- DO NOT store or use gasoline, or other flammable liquids in the vicinity of this or any other appliance. Read product labels for warnings regarding flammability and other hazards.
- DO NOT operate the refrigerator in the presence of explosive fumes.
- Avoid contact with any moving parts of automatic ice maker.
- Remove all staples from the carton. Staples can cause severe cuts, and also destroy finishes if they come in contact with other appliances or furniture.

Definitions

 This is the safety alert symbol. It is used to alert you to potential personal injury hazards. Obey all safety messages that follow this symbol to avoid possible injury or death.



DANGER

DANGER indicates an imminently hazardous situation which, if not avoided, will result in death or serious injury.



WARNING

WARNING indicates a potentially hazardous situation which, if not avoided, could result in death or serious injury.



CAUTION

CAUTION indicates a potentially hazardous situation which, if not avoided, may result in minor or moderate injury.



IMPORTANT

IMPORTANT indicates installation, operation or maintenance information which is important but not hazard-related.



Installation Checklist

Doors

- Handles are secure and tight
- Door seals completely to cabinet on all sides
- Freezer door is level across the top

Leveling

- Refrigerator is level, side-to-side and tilted ¼" (6mm) front-to-back
- Toe grille is properly attached to refrigerator
- Cabinet is setting solid on all corners
- Anti-tip bracket set

Electrical Power

- House power turned on
- Refrigerator plugged in

Ice Maker

- House water supply connected to refrigerator
- No water leaks present at all connections - recheck in 24 hours
- Ice maker is turned ON
- Ice & water dispenser operates correctly
- Front filter must be flush with filter housing (select models)

Final Checks

- Shipping material removed
- Fresh food and freezer temperatures set
- Crisper humidity controls set
- Registration card sent in

Child Safety

Destroy or recycle the carton, plastic bags, and any exterior wrapping material immediately after the refrigerator is unpacked. Children should never use these items to play. Cartons covered with rugs, bedspreads, plastic sheets or stretch wrap may become airtight chambers, and can quickly cause suffocation.

Proper Disposal of your Refrigerator or Freezer

Risk of child entrapment

Child entrapment and suffocation are not problems of the past. Junked or abandoned refrigerators or freezers are still dangerous – even if they will sit for “just a few days”. If you are getting rid of your old refrigerator or freezer, please follow the instructions below to help prevent accidents.

IMPORTANT SAFETY INSTRUCTIONS

Proper Disposal of Refrigerators/Freezers

We strongly encourage responsible appliance recycling/disposal methods. Check with your utility company or visit www.energystar.gov/recycle for more information on recycling your old refrigerator.

Before you throw away your old refrigerator/freezer:

- Remove doors.
- Leave shelves in place so children may not easily climb inside.
- Have refrigerant removed by a qualified service technician.

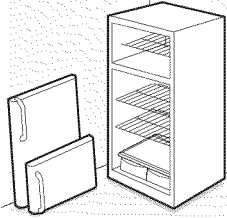

damage the compressor. Such damage is not covered under your warranty.

- Do not plug the unit into an electrical outlet controlled by a wall switch or pull cord to prevent the refrigerator from being turned off accidentally.

IMPORTANT

Turning the Freezer and Fresh Food controls to "0" (Mechanical controls) or "OFF" (Electronic controls) will disable your refrigerator's cooling system, but does not disconnect the power to the light bulb and other electrical components. To turn off power to your refrigerator you must unplug the power cord from the electrical outlet.



WARNING

These guidelines must be followed to ensure that safety mechanisms in this refrigerator will operate properly.



WARNING

Do not attempt to replace LED lights due to high voltage exposure. Call customer service to replace.

Electrical information

- The refrigerator must be plugged into its own dedicated 115 Volt, 60 Hz., 15 Amp, AC only electrical outlet. The power cord of the appliance is equipped with a three-prong grounding plug for your protection against electrical shock hazards. It must be plugged directly into a properly grounded three prong receptacle. The receptacle must be installed in accordance with local codes and ordinances. Consult a qualified electrician. Avoid connecting refrigerator to a Ground Fault Interrupter (GFI) circuit. Do not use an extension cord or adapter plug.
- If the power cord is damaged, it should be replaced by an authorized service technician to prevent any risk.
- Never unplug the refrigerator by pulling on the power cord. Always grip the plug firmly, and pull straight out from the receptacle to prevent damaging the power cord.
- Unplug the refrigerator before cleaning and before replacing a light bulb to avoid electrical shock.
- Performance may be affected if the voltage varies by 10% or more. Operating the refrigerator with insufficient power can

Grounding type wall receptacle

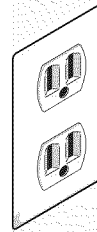

Do not, under any circumstances, cut, remove, or bypass the grounding prong.

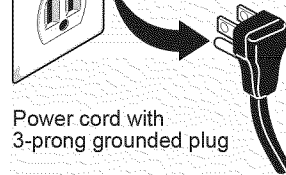

Power cord with 3-prong grounded plug



CAUTION

To avoid personal injury or property damage, handle tempered glass shelves carefully. Shelves may break suddenly if nicked, scratched, or exposed to sudden temperature change.



IMPORTANT

CFC/HCFC Disposal

Your old refrigerator may have a cooling system that used CFCs or HCFCs (chlorofluorocarbons or hydrochlorofluorocarbons). CFCs and HCFCs are believed to harm stratospheric ozone if released to the atmosphere. Other refrigerants may also cause harm to the environment if released to the atmosphere.

If you are throwing away your old refrigerator, make sure the refrigerant is removed for proper disposal by a qualified technician. If you intentionally release refrigerant, you may be subject to fines and imprisonment under provisions of environmental legislation.

FEATURES AT A GLANCE

Features may vary according to model

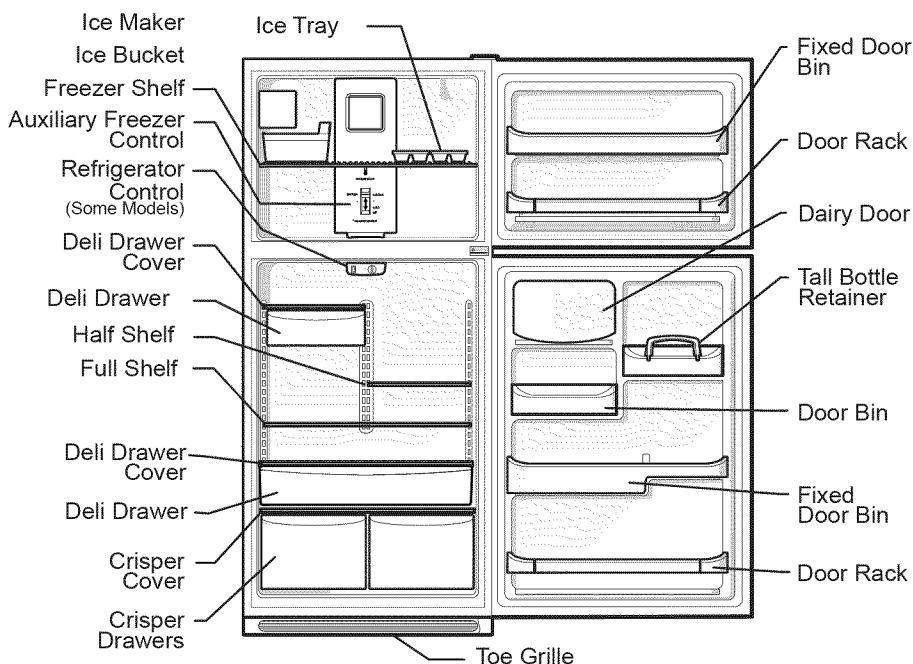

IMPORTANT

Cleaning your Refrigerator

Remove tape and glue residue from surfaces before turning on the refrigerator. Rub a small amount of liquid dish soap over the adhesive with your fingers. Rinse with warm water and dry with a soft cloth.

Do not use sharp instruments, rubbing alcohol, flammable fluids, or abrasive cleaners to remove tape or glue. These products can damage the surface of your refrigerator.

After you remove all of the package materials, clean the inside of your refrigerator before using it. See the "Care & Cleaning" section in this manual.

See important information about cleaning glass shelves and covers in the "Optional Features" section of this manual.

IMPORTANT

Moving your Refrigerator

Your refrigerator is heavy. When moving the refrigerator for cleaning or service, be sure to cover the floor with cardboard or hardboard to avoid floor damage. Always pull the refrigerator straight out when moving it. Do not wiggle or "walk" the refrigerator when trying to move it as floor damage could occur.

INSTALLATION

This Use & Care Guide provides general operating instructions for your model. Use the refrigerator only as instructed in this Use & Care Guide. Before starting the refrigerator, follow these important first steps.

Location

- Choose a place that is near a grounded electrical outlet. Do Not use an extension cord or an adapter plug.
- If possible, place the refrigerator out of direct sunlight and away from the range, dishwasher or other heat sources.
- The refrigerator must be installed on a floor that is level and strong enough to support a fully loaded refrigerator.
- Consider water supply availability for models equipped with an automatic ice maker. If you do not hook up water to the refrigerator, remember to turn the ice maker off.



CAUTION

For optimal performance, do not install the refrigerator where the temperature will drop below 55°F (13°C) or rise above 110°F (43°C). The compressor will not be able to maintain proper temperatures inside the refrigerator.

Do not block the toe grille on the lower front of your refrigerator. Sufficient air circulation is essential for the proper operation of your refrigerator.

Installation

Installation clearances

- Allow the following clearances for ease of installation, proper air circulation, and plumbing and electrical connections:

Sides & Top	3/8 inch
Back	1 inch



NOTE

If your refrigerator is placed with the door hinge side against a wall, you may have to allow additional space so the door can be opened wider.

Guidelines for final positioning of your refrigerator:

- All four corners of the cabinet must rest firmly on the floor.
- The cabinet should be level at the front and rear.
- The sides should tilt 1/4-inch (6 mm) from front-to-back (to ensure that doors close and seal properly).
- Doors should align with each other and be level.

To install the toe grille:

1. The toe grille is packaged with the covers installed or the covers are provided in the literature package. If the covers are provided in the literature package, install toe grille cover onto toe grille slot on side of toe grille corresponding with door handle. See Figure 1.

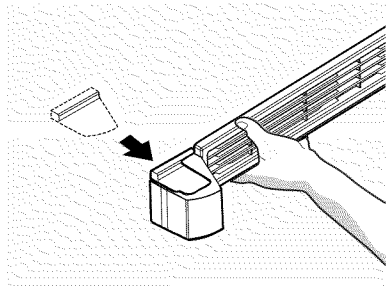

Figure 1

2. If toe grille covers are already installed, remove the cover on the side corresponding with the door hinge bracket. See Figure 2.

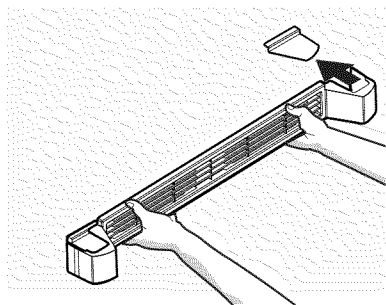

Figure 2

3. Attach toe grille to cabinet. See Figure 3.

INSTALLATION

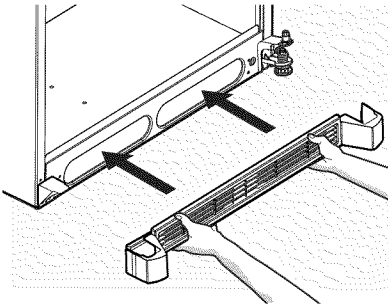
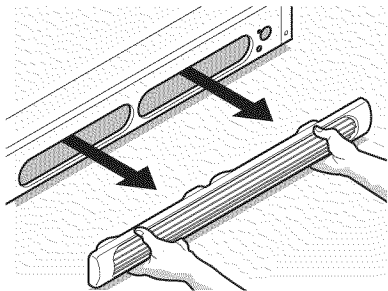

Figure 3

or



some models

To level the cabinet using the front rollers:

- 1 Remove the toe grille.
- 2 Use a flat-blade screwdriver or $\frac{3}{8}$ inch socket wrench to raise or lower the front rollers (Figure 2). Do not raise the cabinet more than $\frac{9}{16}$ inch.

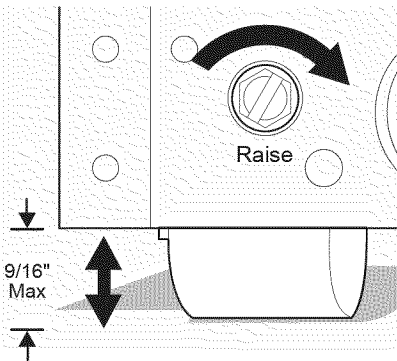

Figure 2

- 3 Use adjustable wrench to adjust leveling screws. Lower the leveling screws on each side clockwise until they contact the floor (Figure 3). Do not raise the cabinet more than $\frac{9}{16}$ inch.

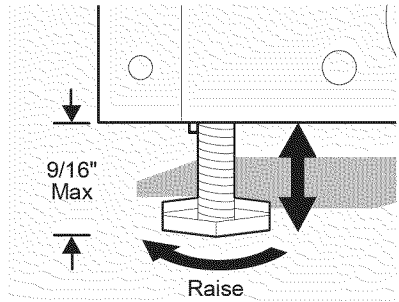
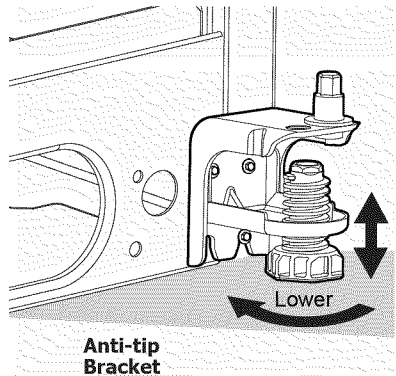

Figure 3

NOTE

Raise the front of the refrigerator enough so the doors close freely when opened halfway. The refrigerator should slope $\frac{1}{4}$ inch to $\frac{1}{2}$ inch from front-to-back. Then level the refrigerator from side-to-side.

- 4 Some models are equipped with an anti-tip bracket (Figure 4). Lower it clockwise until it contacts the floor.



Anti-tip Bracket

Figure 4 (some models)

WARNING



The anti-tip device must be installed according to the instructions in your Use & Care Manual. Failure to do so will result in injury.

WARNING

When reversing the door swing:

You **MUST** move the anti-tip bracket to align with the hinges of the door. Failure to do so will result in injury.

DOOR REMOVAL INSTRUCTIONS

Tools Necessary:

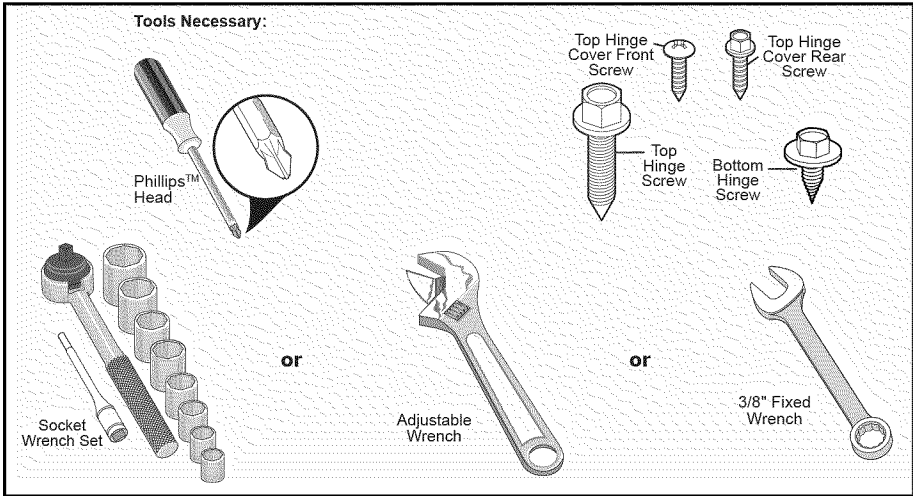

NOTE

The direction in which your refrigerator doors open (door swing) can be reversed, from left to right or right to left, by moving the door hinges from one side to the other. Reversing the door swing should be performed by a qualified person.

IMPORTANT

Before you begin, turn the refrigerator temperature control to "0" (Mechanical controls) or "OFF" (Electronic controls) and remove the electrical power cord from the wall outlet. Remove any food from door shelves.

Door removal and reversal instructions:

1. Remove toe grille.
2. Remove top hinge cover. Trace around the hinge with a soft lead pencil. This makes reinstallation easier. Remove top hinge and lift door off center hinge pin. Set door aside.

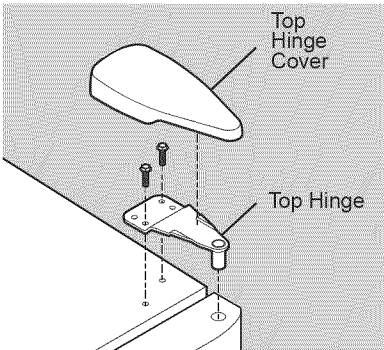

3. Unscrew center hinge pin using adjustable wrench and save for reassembly. Ensure plastic washer stays on hinge pin.

4. Lift refrigerator door off of bottom hinge and set aside.
5. Remove center hinge and shim by removing inside screw and loosening two outside screws enough to allow hinge and shim to slide out. Tighten screws.
6. Loosen two outside screws on opposite side of refrigerator, remove inside screw and install center hinge.

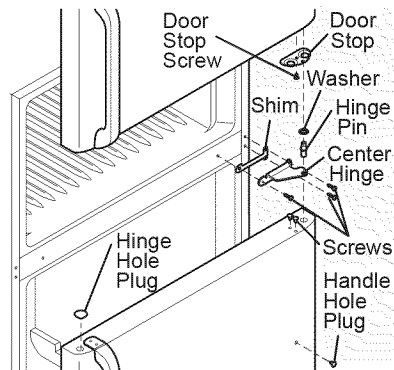

DOOR REMOVAL INSTRUCTIONS

7. Remove three screws on bottom hinge and anti-tip bracket (if equipped) with $\frac{3}{8}$ " socket wrench.
8. Remove toe grille support and screws (if equipped).
9. Install bottom hinge and anti-tip bracket (if equipped) on opposite side with the three screws removed from step 7.
10. Unscrew bottom hinge pin using adjustable wrench. Move hinge pin to other hole in hinge and tighten with adjustable wrench.
11. Install toe grille support and screws on opposite side (if equipped).
12. Reverse door handles (see Handle Installation section).
13. Move freezer and refrigerator door stops to opposite side. Before starting screws, use an awl to puncture the foam.
14. Position refrigerator door onto bottom hinge pin and screw center hinge pin through center hinge into top of door. Close refrigerator door to help align hinge hole.
15. Tighten center hinge pin with adjustable wrench.
16. Remove cabinet and hinge hole plugs and move to opposite side.
17. Lower freezer door onto center hinge pin.
18. Close freezer door. Have an assistant lift up on opposite side of door while tightening screws to install top hinge.
19. There are two toe grille covers provided in your literature packet or already installed on toe grille; one for the right side and one for the left side. Install the appropriate cover over the opening on the side opposite the anti-tip bracket, (see Figures A & B).

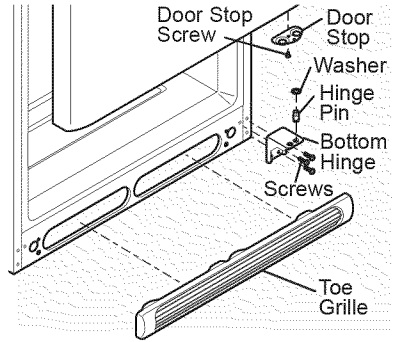

OR

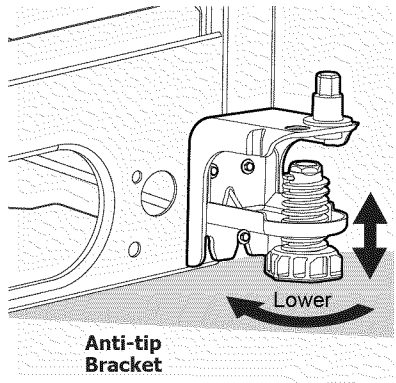

Anti-tip Bracket

NOTE

In case of future door reversals, save the toe grille cover not being used.

20. Reinstall toe grille with appropriate cover (some models).
21. Plug in electrical power cord and turn refrigerator temperature control to center position. Adjust setting as necessary.

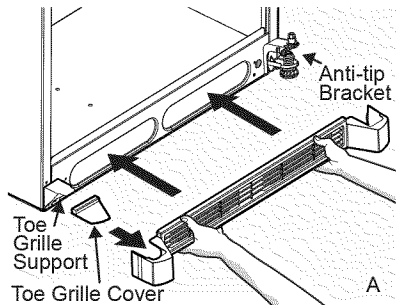

A

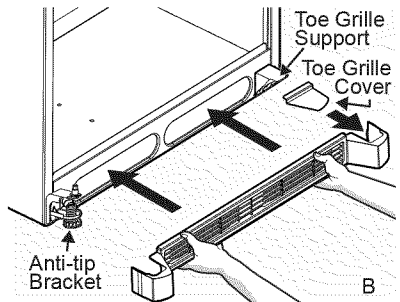

B

WARNING

When reversing the door swing:

You **MUST** move the anti-tip bracket to align with the hinges of the door and install the toe grille support for proper balance. Failure to do so will result in injury.

HANDLE INSTALLATION



CAUTION

Wear gloves and use extreme CAUTION when installing these handles. The rounded end of the handles may be sharp.



IMPORTANT

To ensure proper installation of handles, please review these instructions and illustrations thoroughly prior to installing the handles.

Additionally, before installing the door handles, make sure the door swing is correct. Your model will have either a right hand or left hand door swing. Follow instructions in the Use & Care Guide to reverse the doors, if necessary.

3. Tighten the set screw on the rounded part of the handle until the handle is flush with the door, then tighten another 1/2 turn.

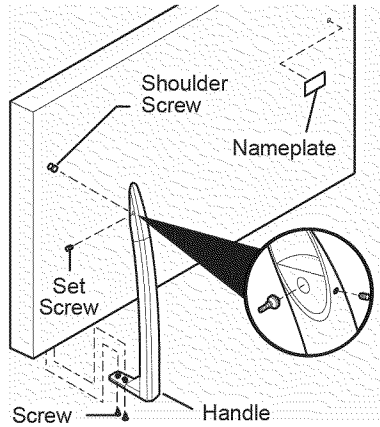

To attach metal refrigerator handle:

1. Place rounded part of handle onto shoulder screw on face of door and align the two holes in top of handle with the two holes in top of door. Do not tighten the set screw yet.
2. Install the two screws into the top of the handle.
3. Tighten the set screw on the rounded part of the handle until the handle is flush with the door, then tighten another 1/2 turn.

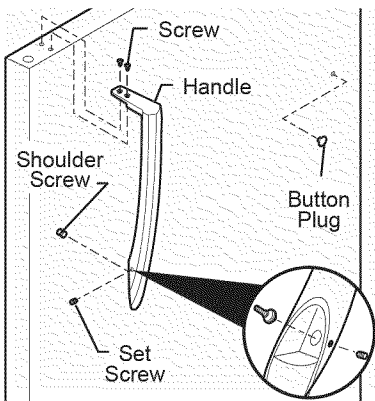

To attach metal freezer handle:

1. Place rounded part of handle onto shoulder screw on face of door and align the two holes in bottom of handle with the two holes in bottom of door. Do not tighten the set screw yet.
2. Install the two screws into the bottom of the handle.

Stainless Steel Models

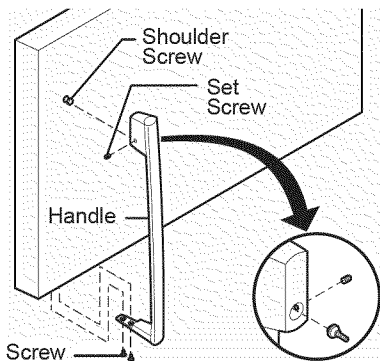
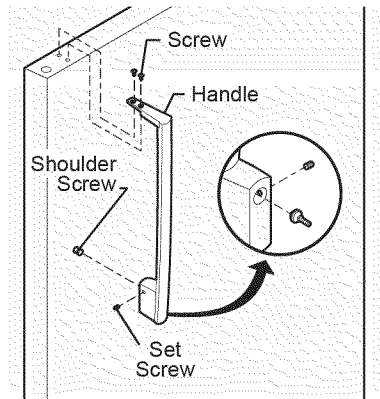

HANDLE INSTALLATION

To attach plastic refrigerator handle:

1. Place top of handle over dovetail screw, pull handle straight down until handle is aligned with screw holes on top of door.
2. Secure top of handle with two screws.

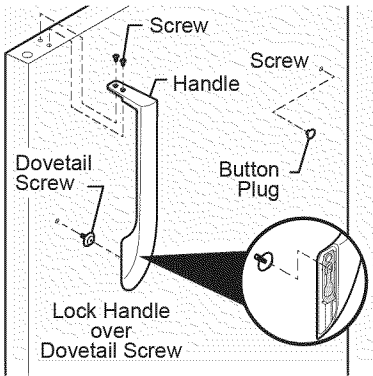

To reverse refrigerator/freezer handles:

Handles may be easier to reverse while doors are off. Reverse freezer and refrigerator handles as shown.

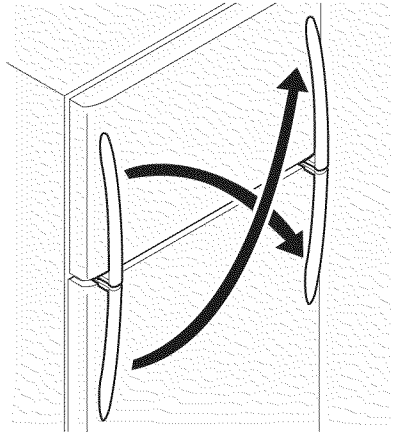

To attach plastic freezer handle:

1. Place top of handle over dovetail screw, pull handle straight up until handle is aligned with screw holes on bottom of door.
2. Secure bottom of handle with two screws.

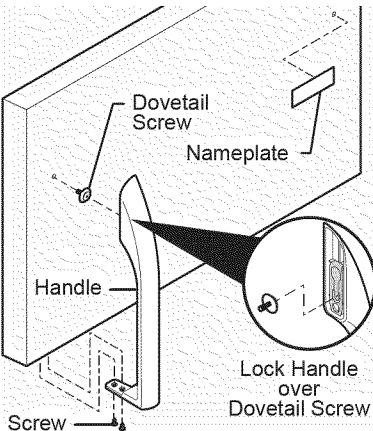

CAUTION

Be sure doors are set aside in a secure position where they cannot fall and cause personal injury.

CONNECTING THE WATER SUPPLY

WARNING

To avoid electric shock, which can cause death or severe personal injury, disconnect the refrigerator from electrical power before connecting a water supply line to the refrigerator.

CAUTION

To Avoid Property Damage:

- Copper or Stainless Steel braided tubing is recommended for the water supply line. Water supply tubing made of ¼ inch plastic is not recommended to be used. Plastic tubing greatly increases the potential for water leaks, and the manufacturer will not be responsible for any damage if plastic tubing is used for the supply line.
- DO NOT install water supply tubing in areas where temperatures fall below freezing.
- Chemicals from a malfunctioning softener can damage the ice maker. If the ice maker is connected to soft water, ensure that the softener is maintained and working properly.

IMPORTANT

Ensure that your water supply line connections comply with all local plumbing codes.

Before Installing The Water Supply Line, You Will Need:

- Basic Tools: adjustable wrench, flat-blade screwdriver, and Phillips™ screwdriver
- Access to a household cold water line with water pressure between 30 and 100 psi.
- A water supply line made of ¼ inch (6.4 mm) OD, copper or stainless steel tubing. To determine the length of tubing needed, measure the distance from the ice maker inlet valve at the back of the refrigerator to your cold water pipe. Then add approximately 7 feet (2.1 meters), so the refrigerator can be moved out for cleaning (as shown).
- A shutoff valve to connect the water supply line to your household water system. DO NOT use a self-piercing type shutoff valve.
- Do not re-use compression fitting or use thread seal tape.

- A compression nut and ferrule (sleeve) for connecting a copper water supply line to the ice maker inlet valve.

NOTE

Check with your local building authority for recommendations on water lines and associated materials prior to installing your new refrigerator. Depending on your local/state building codes, Frigidaire recommends for homes with existing valves its **Smart Choice**® water line kit 5305513409 (with a 6 ft. Stainless Steel Water Line) and for homes without an existing valve, Frigidaire recommends its **Smart Choice**® water line kit 5305510264 (with a 20 ft. Copper Water Line with self-tapping saddle valve). Please refer to www.frigidaire.com/store for more information.

CONNECTING THE WATER SUPPLY

To Connect Water Supply Line To Ice Maker Inlet Valve

1. Disconnect refrigerator from electric power source.
2. Place end of water supply line into sink or bucket. Turn ON water supply and flush supply line until water is clear. Turn OFF water supply at shutoff valve.
3. Remove plastic cap from water valve inlet and discard cap.
4. If you use copper tubing - Slide brass compression nut, then ferrule (sleeve) onto water supply line. Push water supply line into water valve inlet as far as it will go ($\frac{1}{4}$ inch / 6.4 mm). Slide ferrule (sleeve) into valve inlet and finger tighten compression nut onto valve. Tighten another half turn with a wrench; DO NOT over tighten. See Figure 1.

If you use stainless steel tubing - The nut and ferrule are already assembled on the tubing. Slide compression nut onto valve inlet and finger tighten compression nut onto valve. Tighten another half turn with a wrench; DO NOT over tighten. See Figure 2.

5. With steel clamp and screw, secure water supply line (copper tubing only) to rear panel of refrigerator as shown.
6. Coil excess water supply line (copper tubing only), about $2\frac{1}{2}$ turns, behind refrigerator as shown and arrange coils so they do not vibrate or wear against any other surface.
7. Turn ON water supply at shutoff valve and tighten any connections that leak.
8. Reconnect refrigerator to electrical power source.
9. To turn ice maker on, lower wire signal arm (side mounted) or set the ice maker's On/Off power switch to the "I" position (rear mounted).

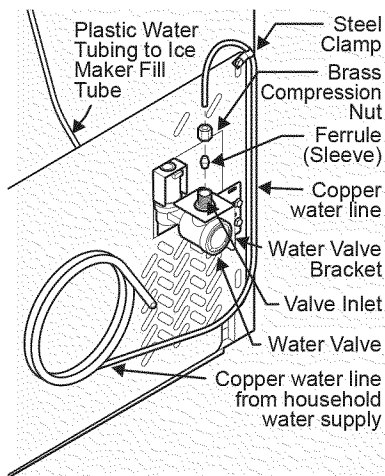

(Include enough tubing in loop to allow moving refrigerator out for cleaning.)

Figure 1

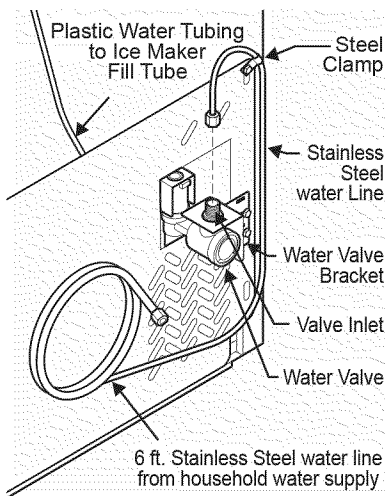

Figure 2

ICE SERVICE

If your refrigerator has an automatic ice maker, minimal ice will be produced during the first 24 hours of operation. Air in new plumbing lines may cause the ice maker to cycle two or three times before making a full tray of ice. With no usage, it will take approximately one to two days to fill the ice container.

New plumbing connections may cause the first production of ice cubes to be discolored or have an odd flavor. Discard ice made during the first 24 hours.

NOTE

Automatic ice makers are also optional accessories that may be installed in most models at any time. Call your local dealer for information.

Turning your Ice Maker On

After the plumbing connections have been completed, the water supply valve must be opened. Place the ice container under the ice maker, pushing it as far back as possible. Lower the wire signal arm to its "down" or ON position.

Turning your Ice Maker Off

To stop the ice maker, lift the wire signal arm until it clicks and locks in the "up" or OFF position. The ice maker also turns off automatically when the ice container is full.

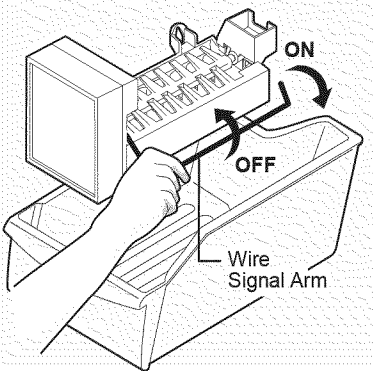

IMPORTANT

Your ice maker is shipped from the factory with the wire signal arm in the ON position. To ensure proper function for your ice maker, hook up water supply immediately or turn ice maker OFF by lifting the wire signal arm until it clicks and locks in the UP position. If the ice maker is on and the water supply is not connected, the water valve will make a loud chattering noise.

ICE PRODUCTION: WHAT TO EXPECT

The ice maker will produce 2.5 to 3 pounds of ice every 24 hours depending on usage conditions. Ice is produced at a rate of 8 cubes every 80 to 160 minutes.



CAUTION

Do Not place the ice container in your dishwasher.

Cool Down Period

To ensure safe food storage, allow the refrigerator to operate with the doors closed for at least 8 hours before loading it with food.

Refrigerator & Freezer Controls (some models)

NOTE

When first turning refrigerator on, adjust the refrigerator control to Normal. This is the recommended initial setting. After 24 hours, adjust the controls as needed.

NOTE

If your unit is in a garage or area where the temperature is below 55°, adjust the freezer control to the coldest setting to improve performance.

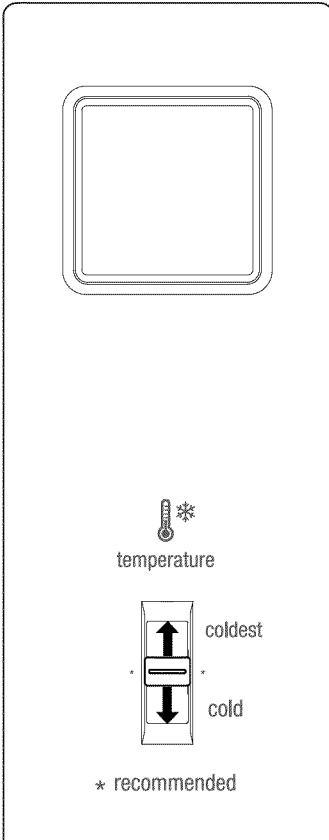

Auxiliary Freezer Control

Cool Down Period

To ensure safe food storage, allow the refrigerator to operate with the doors closed for at least 8 hours before loading it with food.

Refrigerator & Freezer Controls (some models)

NOTE

It may take up to 10 minutes for the compressor to start when first turned on or after power interruption.

NOTE

When first turning refrigerator on, adjust control to Normal. This is the recommended initial setting. After 24 hours, adjust the controls as needed.

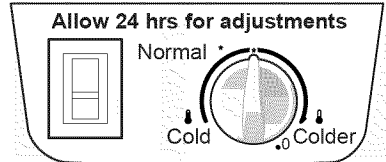

Refrigerator/Freezer Control Temperature Adjustment

- Adjust temperature gradually: adjust the knob in small increments, allowing the temperature to stabilize.
- For colder temperatures, adjust the knob towards **Colder**.
- For warmer temperatures, adjust the knob towards **Cold**.

Adjusting the refrigerator/freezer control will change temperatures in both compartments. The auxiliary freezer control can be left at the factory pre-set (Normal) or adjusted as desired; it has no effect on electrical power to the refrigerator.

To maintain temperatures, a fan circulates air in the refrigerator and freezer compartments. For good circulation, do not block cold air vents with food items.

IMPORTANT

Adjusting the refrigerator/freezer temperature control to "0" turns off the compressor and prevents the refrigerator from cooling, but does not disconnect the power to the light bulb and other electrical components. To turn off power to your refrigerator, you must unplug the power cord from the wall outlet.

CONTROLS

Temperature Adjustment

- Adjust temperature gradually: adjust the knob in small increments, allowing the temperature to stabilize.

Adjusting the refrigerator/freezer control will change temperatures in both compartments. The auxiliary freezer control can be left at the factory pre-set (Normal) or adjusted as desired; it has no effect on electrical power to the refrigerator.

To maintain temperatures, a fan circulates air in the refrigerator and freezer compartments. For good circulation, do not block cold air vents with food items.



IMPORTANT

Adjusting the refrigerator/freezer temperature control to "off" turns off the compressor and prevents the refrigerator from cooling, but does not disconnect the power to the light bulb and other electrical components. To turn off power to your refrigerator, you must unplug the power cord from the wall outlet.

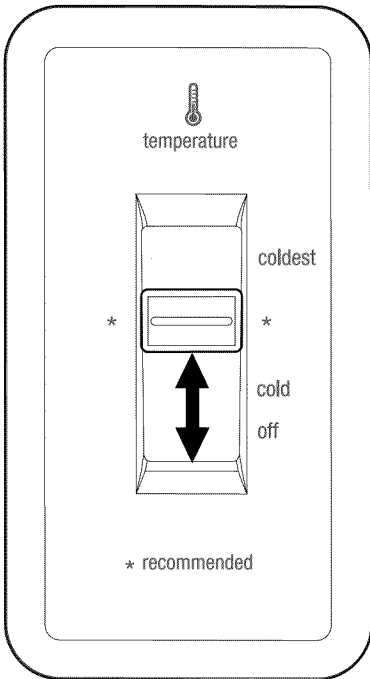

Refrigerator/Freezer Control

OPTIONAL FEATURES



CAUTION

Do not clean glass shelves or covers with warm water when they are cold. Shelves and covers may break if exposed to sudden temperature changes or impact, such as bumping. Tempered glass is designed to shatter into many small, pebble-size pieces. This is normal. Glass shelves and covers are heavy. Use both hands when removing them to avoid dropping.

Shelf Adjustment

Refrigerator shelves are easily adjusted to suit individual needs. Before adjusting the shelves, remove all food.

To adjust sliding shelves:

1. Remove shelf by pulling forward to stop position.
2. Lift front edge up and pull out.

To replace shelf, rest side edges on any pair of shelf rails and carefully push shelf back into position.

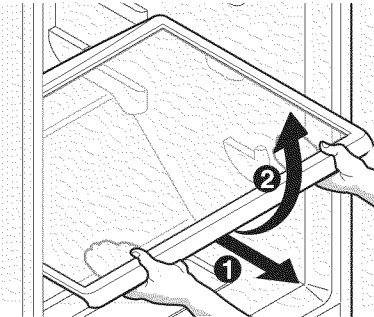

Sliding Glass Shelf

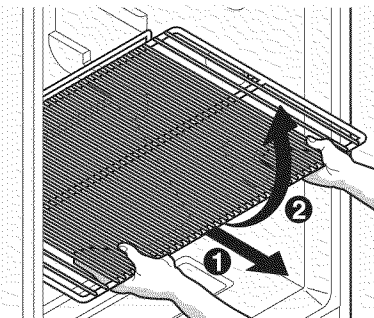

Sliding Wire Shelf

To adjust slide-under/flip shelf:

1. Pull shelf forward until the back of the shelf drops down, then gently push shelf back and under.
2. Lift front of shelf to flip it upwards toward the back of the cabinet.

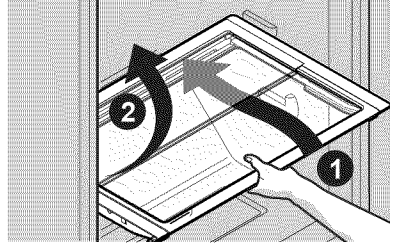

Slide-Under/Flip Shelf

Door storage

Door bins, shelves, and racks are provided for convenient storage of jars, bottles, and cans. Frequently used items can be quickly selected.

The dairy compartment, which is warmer than the general food storage section, is intended for short term storage of cheese, spreads, or butter.

Door rack

Some models have door racks or bins that can accommodate gallon-sized plastic drink containers and economy-sized jars and containers.

To remove door rack:

1. Push on rack sides to release from locking tabs.
2. Pull straight out.

To install door rack:

1. Push rack straight ahead.
2. You will hear the sides lock into the tabs.

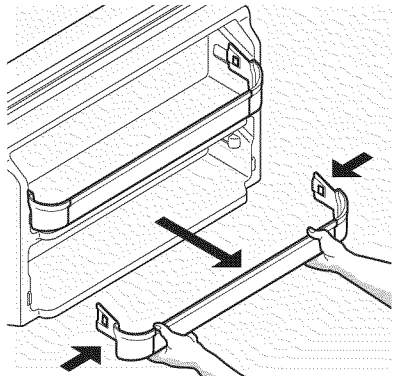

Door Rack

OPTIONAL FEATURES

Adjustable door bins

Some models have adjustable door bins that can be moved to suit individual needs.

To move door bin along a rail:

1. Tilt bin up so the back of the bin is off the door but the hook is still engaged.
2. Slide bin along rail to desired position.
3. Lower bin back into place.

To move door bin from rail to rail:

1. Lift bin up disengaging the hook.
2. Move bin to desired rail location.
3. Push bin hook into rail engaging the hook.

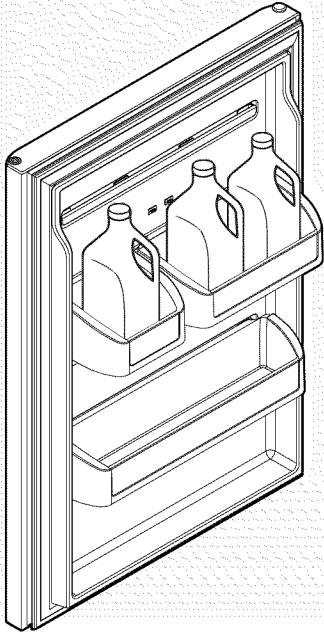

Crisper Humidity Control (some models)

The crisper humidity control, present on the crisper drawers of some models, allows you to adjust the humidity within the crisper. This can extend the life of fresh vegetables that keep best in high humidity.

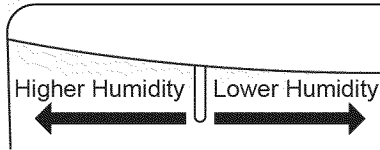
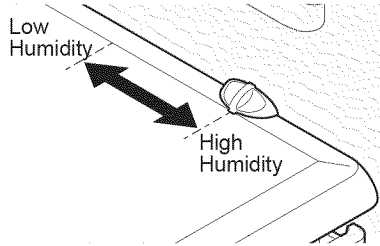

NOTE

Leafy vegetables keep best when stored with the Humidity Control set on High Humidity, or in a drawer without a Humidity Control. This keeps incoming air to a minimum and maintains maximum moisture content. Store non-leafy vegetables and fruits still in their skins at the low humidity setting.

Pantry Drawer (some models)

Some models are equipped with a Pantry Drawer for storage of luncheon meats, spreads, cheeses, and other deli items. Please be sure to support glass when removing the drawer.

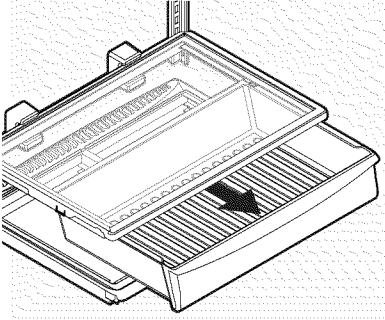

Crispers (some models)

The crispers, located under the bottom refrigerator shelf, are designed for storing fruits, vegetables, and other fresh produce. Wash items in clear water and remove excess water before placing them in the crispers. Items with strong odors or high moisture content should be wrapped before storing.

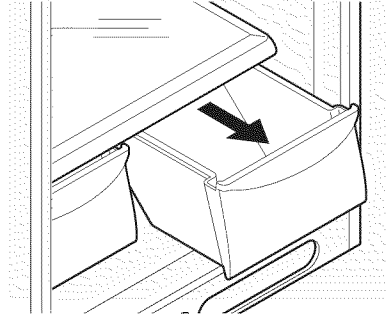

Store-More Drawer (some models)

The Store-More Drawer is located at the top of the refrigerator cabinet directly under the freezer.

To install the Store-More Drawer:

1. Place tabs on back of bin into openings on rear clips on back of slides.
2. Ensure front clips on slides engage into square openings on bin.

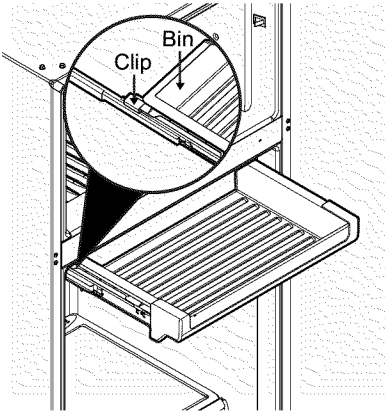

NORMAL OPERATING SOUNDS AND SIGHTS

Understanding the sounds you may hear

Your new, high-efficiency refrigerator may introduce unfamiliar sounds. These sounds normally indicate your refrigerator is operating correctly. Some surfaces on floors, walls, and kitchen cabinets may make these sounds more noticeable.

NOTE

Rigid foam insulation is very energy efficient, but is not a sound insulator.

Following is a list of major components in your refrigerator and the sounds they can cause:

- A Evaporator** Refrigerant through the evaporator may create a boiling or gurgling sound.
- B Evaporator fan** You may hear air being forced through the refrigerator by the evaporator fan.
- C Defrost heater** During defrost cycles, water dripping onto the defrost heater may cause a hissing or sizzling sound. After defrosting, a popping sound may occur.

IMPORTANT

During the automatic defrost cycle, you may notice a red glow in the vents on the back wall of your freezer compartment. This is normal during the defrost cycle.

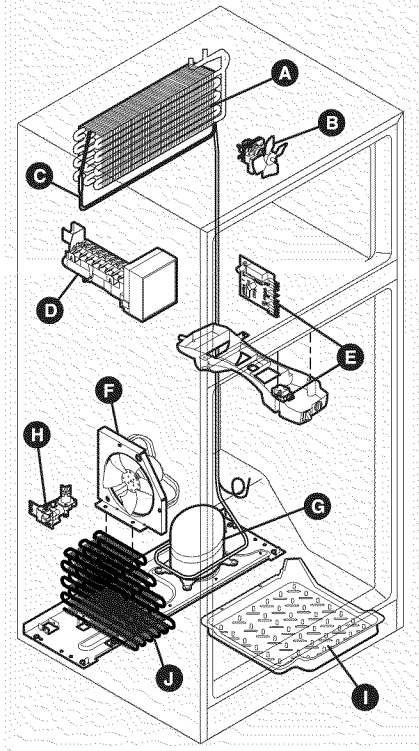

- D Automatic ice maker** When ice has been produced, you will hear ice cubes falling into the ice bin.
- E Electronic defrost control** These parts can produce a snapping or clicking sound when turning the cooling system on and off. Control box may differ from the one shown.
- F Condenser fan** You may hear air being forced through the condenser.
- G Compressor** Modern, high-efficiency compressors run much faster than in the past. The compressor may have a high-pitched hum or pulsating sound.
- H Water valve** If your refrigerator is equipped with an automatic ice maker, you will hear a buzzing sound as the water valve opens to fill the ice maker during each cycle.
- I Drain pan** (not removable) You may hear water dripping into the drain pan during the defrost cycle.
- J Condenser** May create minimal sounds from forced air.

IMPORTANT

If the Fresh Food door is left open for more than 5 minutes, an alarm will sound. The alarm will sound for 2 minutes and then stop. If the "Door Ajar" condition remains, the alarm will repeat every 30 minutes for two intervals.

After 15 minutes of a "Door Ajar" Condition, the unit will turn the Fresh Food light off until the door is closed. The door switch in the Fresh Food can be pressed and released to reset the alarm and light.

Protecting your investment

Keeping your refrigerator clean maintains appearance and prevents odor build-up. Wipe up any spills immediately and clean the freezer and fresh food compartments at least twice a year. When cleaning, take the following precautions:

- Never use CHLORIDE or cleaners with bleach to clean stainless steel.
- Do not wash any removable parts in a dishwasher.
- Always unplug the electrical power cord from the wall outlet before cleaning.
- Remove adhesive labels by hand. Do not use razor blades or other sharp instruments which can scratch the appliance surface.
- Do not remove the serial plate.

Do not use abrasive cleaners such as window sprays, scouring cleansers, brushes, flammable fluids, cleaning waxes, concentrated detergents, bleaches or cleansers containing petroleum products on plastic parts, interior doors, gaskets or cabinet liners. Do not use paper towels, metallic scouring pads, or other abrasive cleaning materials or strong alkaline solutions.



NOTE

If you set your temperature controls to turn off cooling, power to lights and other electrical components will continue until you unplug the power cord from the wall outlet.



IMPORTANT

If you store or move your refrigerator in freezing temperatures, be sure to completely drain the water supply system. Failure to do so could result in water leaks when the refrigerator is put back into service. Contact a service representative to perform this operation.



CAUTION

- Pull the refrigerator straight out to move it. Shifting it from side to side may damage flooring. Be careful not to move the refrigerator beyond the plumbing connections.
- Damp objects stick to cold metal surfaces. Do not touch refrigerated surfaces with wet or damp hands.

CARE & CLEANING

Care & Cleaning Tips		
Part	What To Use	Tips and Precautions
Interior & Door Liners	<ul style="list-style-type: none"> • Soap and water • Baking soda and water 	Use 2 tablespoons of baking soda in 1 quart of warm water. Be sure to wring excess water out of sponge or cloth before cleaning around controls, light bulb or any electrical part.
Door Gaskets	<ul style="list-style-type: none"> • Soap and water 	Wipe gaskets with a clean soft cloth.
Drawers & Bins	<ul style="list-style-type: none"> • Soap and water 	Use a soft cloth to clean drawer runners and tracks.
Glass Shelves	<ul style="list-style-type: none"> • Soap and water • Glass cleaner • Mild liquid sprays 	Allow glass to warm to room temperature before immersing in warm water.
Toe Grille	<ul style="list-style-type: none"> • Soap and water • Mild liquid sprays • Vacuum attachment 	Vacuum dust from front of toe grille. Remove toe grille (see Installation Instructions). Vacuum backside, wipe with sudsy cloth or sponge. Rinse and dry.
Exterior & Handles	<ul style="list-style-type: none"> • Soap and water • Non Abrasive Glass Cleaner 	Do not use commercial household cleaners containing ammonia, bleach or alcohol to clean handles. Use a soft cloth to clean smooth handles. DO NOT use a dry cloth to clean smooth doors.
Exterior & Handles (Stainless Steel Models Only)	<ul style="list-style-type: none"> • Soap and water • Stainless Steel Cleaners 	<p>Never use CHLORIDE or cleaners with bleach to clean stainless steel.</p> <p>Clean stainless steel front and handles with non-abrasive soapy water and a dishcloth. Rinse with clean water and a soft cloth. Use a non-abrasive stainless steel cleaner. These cleaners can be purchased at most home improvement or major department stores. Always follow manufacturer's instructions. Do not use household cleaners containing ammonia or bleach.</p> <p>NOTE: Always clean, wipe and dry with the grain to prevent scratching. Wash the rest of the cabinet with warm water and mild liquid detergent. Rinse well, and wipe dry with a clean soft cloth.</p>
Replacing Light Bulbs	<ul style="list-style-type: none"> • Unplug refrigerator • Wear gloves • Remove light cover (some models) • Replace old bulb • Replace light cover (some models) • Plug in the refrigerator 	CAUTION: Wear gloves when replacing light bulbs to avoid getting cut. Use same wattage when replacing bulb
LED Bulbs	<ul style="list-style-type: none"> • Call customer service to replace 	WARNING: Do not attempt to replace LED lights due to high voltage exposure.

1-800-944-9044 (United States)
1-800-265-8352 (Canada)

Visit our web site at
www.frigidaire.com.

Common Occurrences	Before calling for service, review this list. It may save you time and expense. This list includes common occurrences that are not the result of defective workmanship or materials in this appliance.
Refrigerator does not run.	<ul style="list-style-type: none"> • Ensure plug is tightly pushed into electrical outlet. • Check/replace fuse with a 15 amp time-delay fuse. Reset circuit breaker. • The refrigerator/freezer control is turned to "0" (Mechanical controls) or "OFF" (Electronic controls). • Refrigerator may be in defrost cycle. Wait 20 minutes and check again.
Freezer temperature is colder than preferred. Refrigerator temperature is satisfactory.	<ul style="list-style-type: none"> • Set auxiliary freezer control to a warmer setting until freezer temperature is satisfactory. Allow 24 hours for the temperature to stabilize.
Refrigerator temperature is too cold. Freezer temperature is satisfactory.	<ul style="list-style-type: none"> • Set refrigerator/freezer control to a warmer setting. Allow 24 hours for temperature to stabilize. Then check freezer temperatures and adjust as needed.
Freezer temperature is warmer than preferred. Refrigerator temperature is satisfactory.	<ul style="list-style-type: none"> • Set auxiliary freezer control to a colder setting until freezer temperature is satisfactory. Allow 24 hours for the temperature to stabilize.
Refrigerator temperature is warmer than preferred. Freezer temperature is satisfactory.	<ul style="list-style-type: none"> • Set refrigerator/freezer control to a colder setting. Allow 24 hours for temperature to stabilize. Then check refrigerator temperatures and adjust as needed.
Refrigerator is noisy or vibrates.	<ul style="list-style-type: none"> • The cabinet is not level. • Floor is weak. • See Normal Operating Sounds and Sights section.
Odors in refrigerator.	<ul style="list-style-type: none"> • Interior needs to be cleaned. • Foods that produce odors should be covered or wrapped.
Cabinet light not working.	<ul style="list-style-type: none"> • Replace light bulb. • Ensure plug is tightly pushed into electrical outlet. • Light switch may be stuck. Push in light switch, located on the refrigerator control box, to release.
Automatic ice maker not working (some models)	<ul style="list-style-type: none"> • Ensure the wire signal arm is not in UP position. • Ice maker should produce 2.5 to 3 pounds of ice in a 24 hour period. • Water supply is turned off. • Water pressure is too low. • The freezer is not cold enough.
Refrigerator makes beeping sound.	<ul style="list-style-type: none"> • Close door. • Press light switch.

MAJOR APPLIANCE WARRANTY

Major Appliance Warranty Information

Your appliance is covered by a one year limited warranty. For one year from your original date of purchase, Crosley will pay all costs for repairing or replacing any parts of this appliance that prove to be defective in materials or workmanship when such appliance is installed, used and maintained in accordance with the provided instructions.

*In addition to warranty shown above, ask your dealer about Crosley Extended Limited Warranty that comes to you at no extra charge for the 2nd through 10th years.

Exclusions This warranty does not cover the following:

1. Products with original serial numbers that have been removed, altered or cannot be readily determined.
2. Product that has been transferred from its original owner to another party or removed outside the USA or Canada.
3. Rust on the interior or exterior of the unit.
4. Products purchased "as-is" are not covered by this warranty.
5. Food loss due to any refrigerator or freezer failures.
6. Products used in a commercial setting.
7. Service calls which do not involve malfunction or defects in materials or workmanship, or for appliances not in ordinary household use or used other than in accordance with the provided instructions.
8. Service calls to correct the installation of your appliance or to instruct you how to use your appliance.
9. Expenses for making the appliance accessible for servicing, such as removal of trim, cupboards, shelves, etc., which are not a part of the appliance when it is shipped from the factory.
10. Service calls to repair or replace appliance light bulbs, air filters, water filters, other consumables, or knobs, handles, or other cosmetic parts.
11. Surcharges including, but not limited to, any after hour, weekend, or holiday service calls, tolls, ferry trip charges, or mileage expense for service calls to remote areas, including the state of Alaska.
12. Damages to the finish of appliance or home incurred during installation, including but not limited to floors, cabinets, walls, etc.
13. Damages caused by: services performed by unauthorized service companies; use of parts other than genuine Crosley parts or parts obtained from persons other than authorized service companies; or external causes such as abuse, misuse, inadequate power supply, accidents, fires, or acts of God.

DISCLAIMER OF IMPLIED WARRANTIES; LIMITATION OF REMEDIES

CUSTOMER'S SOLE AND EXCLUSIVE REMEDY UNDER THIS LIMITED WARRANTY SHALL BE PRODUCT REPAIR OR REPLACEMENT AS PROVIDED HEREIN. CLAIMS BASED ON IMPLIED WARRANTIES, INCLUDING WARRANTIES OF MERCHANTABILITY OR FITNESS FOR A PARTICULAR PURPOSE, ARE LIMITED TO ONE YEAR OR THE SHORTEST PERIOD ALLOWED BY LAW, BUT NOT LESS THAN ONE YEAR. CROSELY SHALL NOT BE LIABLE FOR CONSEQUENTIAL OR INCIDENTAL DAMAGES SUCH AS PROPERTY DAMAGE AND INCIDENTAL EXPENSES RESULTING FROM ANY BREACH OF THIS WRITTEN LIMITED WARRANTY OR ANY IMPLIED WARRANTY. SOME STATES AND PROVINCES DO NOT ALLOW THE EXCLUSION OR LIMITATION OF INCIDENTAL OR CONSEQUENTIAL DAMAGES, OR LIMITATIONS ON THE DURATION OF IMPLIED WARRANTIES, SO THESE LIMITATIONS OR EXCLUSIONS MAY NOT APPLY TO YOU. THIS WRITTEN WARRANTY GIVES YOU SPECIFIC LEGAL RIGHTS. YOU MAY ALSO HAVE OTHER RIGHTS THAT VARY FROM STATE TO STATE.

If You Need Service Keep your receipt, delivery slip, or some other appropriate payment record to establish the warranty period should service be required. If service is performed, it is in your best interest to obtain and keep all receipts. Service under this warranty must be obtained by contacting Crosley at the addresses or phone numbers below.

This warranty only applies in the USA and Canada. Your appliance is warranted by Crosley Corporation. Crosley authorizes no person to change or add to any obligations under this warranty. Obligations for service and parts under this warranty must be performed by Crosley or an authorized service company. Product features or specifications as described or illustrated are subject to change without notice.

FOR WARRANTY INFORMATION CONTACT:

USA 800-944-9044
Canada 800-265-8352



FOR PRODUCT INFORMATION CONTACT:

336-761-1212
Crosley Corporation
111 Cloverleaf Dr.
Suite 200
Winston-Salem, NC 27103
www.crosley.com