

Use & Care Guide  
Manual de Uso y Cuidado  
Manuel d'utilisation et d'entretien  
English / Español / Français

Models/Modelos/Modèles: 790.31113 & 790.31123

# Kenmore Elite®

## Downdraft Gas Cooktop

## Parrilla de Cocinar a gas con ventilación

## Table de cuisson à gaz avec hotte intégrée

P/N 318203688C (1506)  
Sears Brands Management Corporation  
Hoffman Estates, IL 60179 U.S.A.  
[www.kenmore.com](http://www.kenmore.com)  
[www.sears.com](http://www.sears.com)

P/N 318203688C (1506)  
Sears Canada Inc., Toronto,  
Ontario, Canada M5B 2C3  
[www.sears.ca](http://www.sears.ca)



---

## Table of Contents

Kenmore Elite Warranty.....	2	Cleaning Various Parts of Your Cooktop .....	11
IMPORTANT SAFETY INSTRUCTIONS .....	3-4	Porcelain Enamel Cooktop Cleaning Instructions.....	11
Product Record.....	5	Cleaning the Burner Grates.....	12
Serial Plate Location .....	5	Cleaning the Burner Caps.....	12
Grounding Instructions.....	5	Cleaning the Burner Heads.....	12
Liquefied Petroleum (Propane) Gas Conversion.....	5	Cleaning the Vent Grate.....	12
Setting Surface Controls.....	6-7	Cleaning the Vent Grate Seal.....	13
Surface Cooking .....	8	Cleaning the Grease Filter.....	13
Setting the Downdraft Vent System.....	9	Cleaning the Vent Chamber.....	13
Setting Surface Burner Controls.....	9-10	Before You Call .....	14
General Care & Cleaning .....	11-13	Master Protection Agreements .....	15
		Sears Service.....	Back Cover

---

## KENMORE ELITE LIMITED WARRANTY

FOR ONE YEAR from the date of sale this appliance is warranted against defects in material or workmanship when it is correctly installed, operated and maintained according to all supplied instructions.

WITH PROOF OF SALE, a defective appliance will receive free repair or replacement at option of seller.

For warranty coverage details to obtain free repair or replacement, visit the web page: [www.kenmore.com/warranty](http://www.kenmore.com/warranty)

This warranty applies for only 90 DAYS from the sale date in the United States, and is void in Canada, if this appliance is ever used for other than private household purposes.

**This warranty covers ONLY defects in material and workmanship, and will NOT pay for:**

1. Cracks in a ceramic glass cooktop that are not a result of thermal shock.
2. Stains and scratches on a ceramic glass cooktop resulting from accident or improper operation or maintenance.
3. Discoloration of cooktop surfaces resulting from normal use.
4. Expendable items that can wear out from normal use, including but not limited to filters, belts, bags or screw-in base light bulbs.
5. A service technician to clean or maintain this appliance, or to instruct the user in correct appliance installation, operation and maintenance.
6. Service calls to correct appliance installation not performed by Sears authorized service agents, or to repair problems with house fuses, circuit breakers, house wiring, and plumbing or gas supply systems resulting from such installation.
7. Damage to or failure of this appliance resulting from installation not performed by Sears authorized service agents, including installation that was not in accord with electrical, gas or plumbing codes.
8. Damage to or failure of this appliance, including discoloration or surface rust, if it is not correctly operated and maintained according to all supplied instructions.
9. Damage to or failure of this appliance, including discoloration or surface rust, resulting from accident, alteration, abuse, misuse or use for other than its intended purpose.
10. Damage to or failure of this appliance, including discoloration or surface rust, caused by the use of detergents, cleaners, chemicals or utensils other than those recommended in all instructions supplied with the product.
11. Damage to or failure of parts or systems resulting from unauthorized modifications made to this appliance.
12. Service to an appliance if the model and serial plate is missing, altered, or cannot easily be determined to have the appropriate certification logo.

### Disclaimer of implied warranties; limitation of remedies

Customer's sole and exclusive remedy under this limited warranty shall be product repair or replacement as provided herein. Implied warranties, including warranties of merchantability or fitness for a particular purpose, are limited to one year or the shortest period allowed by law. Seller shall not be liable for incidental or consequential damages. Some states and provinces do not allow the exclusion or limitation of incidental or consequential damages, or limitation on the duration of implied warranties of merchantability or fitness, so these exclusions or limitations may not apply to you.

This warranty applies only while this appliance is used in the United States and Canada.\*

This warranty gives you specific legal rights, and you may also have other rights which vary from state to state.

\* In-home repair service is not available in all Canadian geographical areas, nor will this warranty cover user or service travel and transportation expenses if this product is located in a remote area (as defined by Sears Canada Inc.) where an authorized service is not available.

**Sears Brands Management Corporation, Hoffman Estates, IL 60179**  
**Sears Canada Inc., Toronto, Ontario, Canada M5B 2C3**

# IMPORTANT SAFETY INSTRUCTIONS

Read all instructions before using this appliance. Save these instructions for future reference.

This manual contains important safety symbols and instructions. Please pay attention to these symbols and follow all instructions given.

**⚠ WARNING** This symbol will help alert you to situations that may cause serious bodily harm, death or property damage.

**⚠ CAUTION** This symbol will help alert you to situations that may cause bodily injury or property damage.

**⚠ WARNING** If the information in this manual is not followed exactly, a fire or explosion may result causing property damage, personal injury or death.

## FOR YOUR SAFETY:

- DO NOT store or use gasoline or other flammable vapors and liquids in the vicinity of this or any other appliance.
- WHAT TO DO IF YOU SMELL GAS:
  - DO NOT try to light any appliance.
  - DO NOT touch any electrical switch; DO NOT use any phone in your building.
  - Immediately call your gas supplier from a neighbor's phone. Follow the gas supplier's instructions.
  - If you cannot reach your gas supplier, call the fire department.
- Installation and service must be performed by a qualified installer, servicer or the gas supplier.

- Remove all tape and packaging wrap before using the cooktop. Destroy the carton and plastic bags after unpacking the cooktop. Never allow children to play with packaging material. **DO NOT** remove the model/serial plate attached to the cooktop.
- Proper Installation—Be sure your appliance is properly installed and grounded by a qualified technician in accordance with the National Fuel Gas Code ANSI Z223.1 latest edition and CAN/CGA B149.2, and the National Electrical Code ANSI/NFPA No. 70—latest edition, and local code requirements. Install and/or adjust only per installation instructions provided in the literature package for this cooktop.

Sears Parts & Repair is the recommended repair service for this appliance. Know how to disconnect the electrical power to the appliance at the circuit breaker or fuse box in case of an emergency.

- User Servicing—**DO NOT** repair or replace any part of the appliance unless specifically recommended in the manuals. All other servicing should be done only by a qualified technician to reduce the risk of personal injury and damage to the cooktop.

- Never modify or alter the construction of a cooktop by removing panels, wire covers, or any other part of the product.
- Air curtain or other overhead hoods, which operate by blowing a downward air flow on to a range, shall not be used in conjunction with gas ranges other than when the hood and range have been designed, tested and listed by an independent test laboratory for use in combination with each other.

**⚠ WARNING** Stepping or leaning on this cooktop can result in serious injuries and may also cause damage to the cooktop. **DO NOT** allow children to climb or play around the cooktop.

- Storage on Appliance—Flammable materials should not be stored on the cooktop, near surface burners. This includes paper, plastic and cloth items, such as cookbooks, plasticware and towels, as well as flammable liquids. **DO NOT** store explosives, such as aerosol cans, on the cooktop. Flammable materials may explode and result in fire or property damage.

**⚠ CAUTION** **DO NOT** store items of interest to children in the cabinets above the cooktop.

- **DO NOT** leave children alone—Children should not be left alone or unattended in the area where an appliance is in use. They should never be allowed to sit or stand on any part of the appliance.
- **DO NOT TOUCH SURFACE BURNERS, GRATES, OR AREAS NEAR THESE BURNERS.** Surface burners may be hot even though the flames are not visible. Areas near surface burners may become hot enough to cause burns. During and after use, **DO NOT** touch or let clothing or other flammable materials touch these areas until they have had sufficient time to cool. Among these areas are the cooktop and the surfaces facing the cooktop.

- Wear Proper Apparel—Loose-fitting or hanging garments should never be worn while using the appliance. **DO NOT** let clothing or other flammable materials contact hot surfaces.

**⚠ WARNING** **NEVER** use this appliance as a space heater to heat or warm the room. Doing so may result in carbon monoxide poisoning.

# IMPORTANT SAFETY INSTRUCTIONS

- **DO NOT Use Water or Flour on Grease Fires—Smother the fire with a pan lid, or use baking soda, a dry chemical or foam-type extinguisher.**
  - **When heating fat or grease, watch it closely.** Fat or grease may catch fire if allowed to become too hot.
  - **Use Only Dry Potholders—Moist or damp pot holders on hot surfaces may result in burns from steam. DO NOT** let the potholders touch the flame or burners. **DO NOT** use a towel or other bulky cloth instead of a pot holder.
  - **DO NOT Heat Unopened Food Containers—Buildup of pressure may cause container to burst and result in injury.**
  - **Know which knob controls each surface burner.** Always turn the knob to the LITE position when igniting the burners. Visually check that the burner has lit. Then adjust the flame so it does not extend beyond the edge of the utensil.
- ⚠ WARNING Use Proper Flame Size—Adjust flame size so it does not extend beyond the edge of the utensil.** The use of undersized utensils will expose a portion of the burner flame to direct contact and may result in ignition of clothing. Proper relationship of utensil to flame will also improve efficiency.
- ⚠ WARNING DO NOT use stove top grills on your sealed gas burners.** If you use a stove top grill on a sealed gas burner, it will cause incomplete combustion and can result in exposure to carbon monoxide levels above allowable current standards. This can be hazardous to your health.
- ⚠ WARNING Use proper pan size—**This appliance is equipped with one or more surface burners of different sizes. Select utensils having flat bottom large enough to cover the surface burner. The use of undersized utensils will expose a portion of the surface burner to direct contact and may result in ignition of clothing. Proper relationship of utensil to the surface burner will also improve efficiency.
- **Clean the appliance regularly to keep all parts free of grease that could catch fire.** Exhaust fan ventilation hoods and grease filters should be kept clean. **DO NOT** allow grease to accumulate on filter. Greasy deposits in the fan could catch fire.
  - **Utensil Handles Should Be Turned Inward from Edges of Cooktop and Not Extend Over Adjacent Surface Burners—**To reduce the risk of burns, ignition of flammable materials, and spillage due to unintentional contact with the utensil, the handle of the utensil should be positioned so that it is turned inward, and does not extend over adjacent surface burners.
  - **Never Leave Surface Burners Unattended at High Heat Settings—**Boilovers cause smoking and greasy spillovers that may ignite, or a pan that has boiled dry may melt.
  - **Protective Liners—DO NOT** use aluminum foil to line surface burner pans. Protective liners or aluminum foil may interfere with heat and air distribution, and combustion. Damage to the cooktop or personal injury may result.
  - **Glazed Cooking Utensils—**Only certain types of glass, glass/ceramic, ceramic, earthenware, or other glazed utensils are suitable for cooktop service without breaking due to the sudden change in temperature. Check the manufacturer's recommendations for cooktop use.
  - **DO NOT Use Decorative Surface Burner Covers.** If a burner is accidentally turned on, the decorative cover will become hot and possibly melt. You will not be able to see that the burner is on. Burns will occur if the hot covers are touched. Damage may also be done to the cooktop or burners because the covers may cause overheating. Air will be blocked from the burner and cause combustion problems.

## IMPORTANT SAFETY NOTICE

The California Safe Drinking Water and Toxic Enforcement Act requires the Governor of California to publish a list of substances known to the state to cause cancer, birth defects or other reproductive harm, and requires businesses to warn customers of potential exposure to such substances.

---

### Please carefully read and save these instructions

This Use & Care Manual contains general operating instructions for your appliance and feature information for several models. Your product **may not** have all the described features. The graphics shown are representative. The graphics on your appliance may not look exactly like those shown. Common sense and caution must be practiced when installing, operating and maintaining any appliance.

---

## Product Record

In this space below, record the date of purchase, model and serial number of your product. You will find the model and serial number printed on the serial plate. This serial plate is located under the cooktop. **See bottom** of this page for the serial plate location.

Model No. \_\_\_\_\_

Serial No. \_\_\_\_\_

Date of purchase \_\_\_\_\_

Save these instructions and your sales receipt for future reference.

## Serial Plate Location

Please see the illustration for exact location. Remember to record the serial number for future reference.

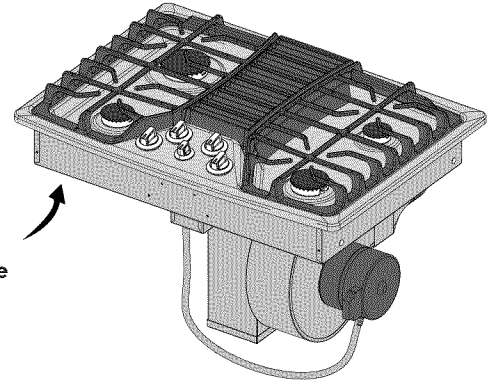

Serial plate is located under the burner box.

## Conversion to Liquefied Petroleum Gas (or L.P. Gas)

This natural gas appliance is designed to allow for conversion to Liquefied Petroleum (L.P.) Gas.

Only a qualified service agent should perform the L. P. conversion. Contact the local gas provider for conversion. The L. P. Conversion Kit is supplied with this unit and is located in the literature package. The kit contains installation

instructions which must be read before and followed carefully when installing the kit.

**⚠ WARNING** To avoid serious injury, any additions, changes or conversions required in order for this appliance to satisfactorily meet the application needs must be made by a qualified service agent.

## Grounding Instructions

For personal safety, the cooktop must be properly grounded. For maximum safety, the power cord must be plugged into an electrical outlet that is correctly polarized and properly grounded.

**DO NOT** operate the cooktop using a 2-prong adapter or an extension cord. If a 2-prong wall receptacle is the only available outlet, it is the personal responsibility of the consumer to have it replaced with a properly grounded 3-prong wall receptacle installed by a qualified electrician.

See the **INSTALLATION INSTRUCTIONS** packaged with this cooktop for complete installation and grounding instructions.

**⚠ WARNING** This appliance is equipped with a 3-prong grounding plug for your protection against shock hazard and should be plugged directly into a properly grounded receptacle. **DO NOT** cut or remove the grounding prong from this plug.

Grounding type wall receptacle

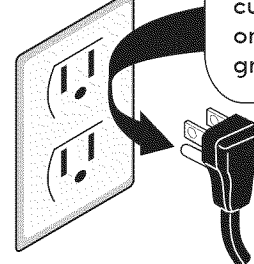

**DO NOT**, under any circumstances, cut, remove, or bypass the grounding prong.

Power supply cord with 3-prong grounding plug

**⚠ WARNING** Avoid fire hazard or electrical shock. **DO NOT** use an adapter plug, an extension cord, or remove grounding prong from electrical power cord. Failure to follow this warning can cause serious injury, fire or death.

## Setting Surface Controls

### Control Locations of the Gas Surface Burners

Your cooktop is equipped with gas surface burners with different BTU ratings. The ability to heat food quicker and in larger volumes increases as the burner size increases.

- The small **SIMMER** burner is best used for simmering delicate sauces, etc.
- The **REGULAR** burners can be used for most surface cooking needs.
- The large **TURBO BOIL** burner is best used for bringing large quantities of liquid rapidly up to temperature or when preparing larger quantities of food.
- The **BRIDGE** burner is best suited when using rectangular or long shaped cookware. The rear and middle burners are combined and controlled by the same control knob. The front burner may also be added for a total of 3 burners.
- The **POWER** burner is best used when preparing larger quantities of food and it quickly bring liquids up to a rolling boil.

Regardless of size, always select cookware that is suitable for the amount and type of food being prepared. Select a burner and flame size appropriate to the pan. Never allow flames to extend beyond the outer edge of the pan.

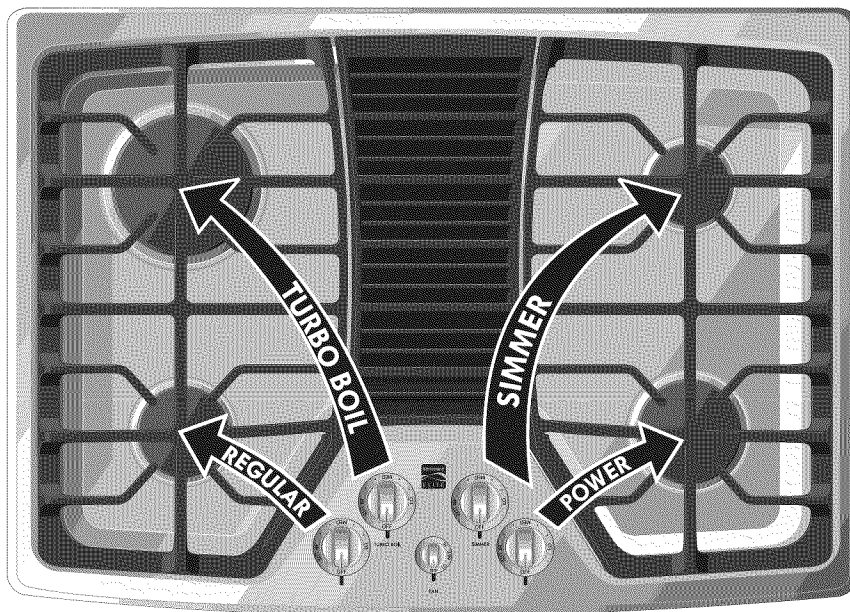

Figure 1 - Model 790.31113

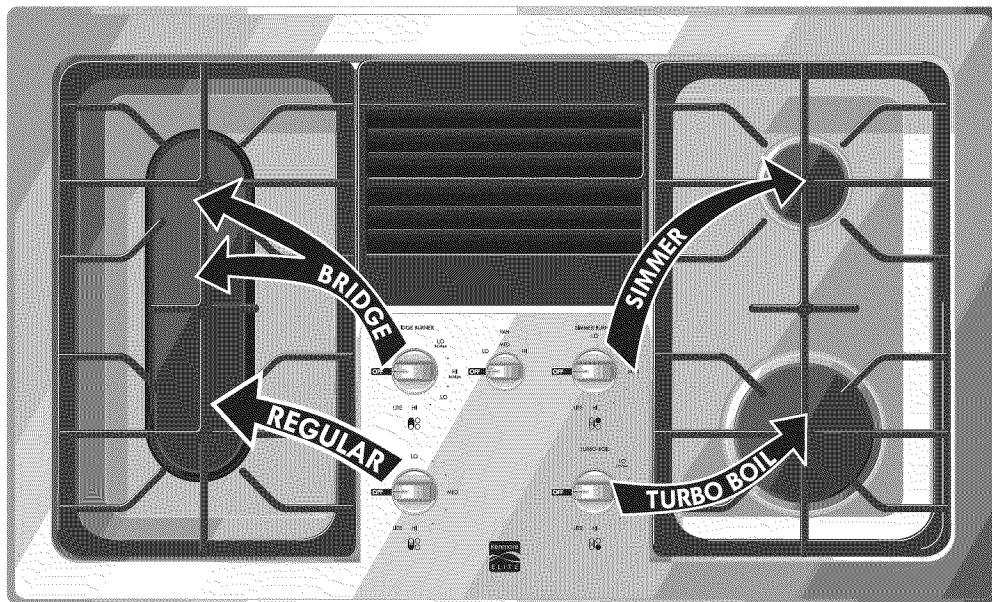

Figure 2 - Model 790.31123

## Setting Surface Controls

### Check Burner Cap Placement Before Operating the Surface Burners

To prevent flare-ups and avoid creation of harmful by-products, **DO NOT** use the cooktop without all burner caps properly installed to ensure proper ignition and gas flame size.

**It is very important** to be sure that all surface burner caps and burner grates are properly installed and in the correct locations **BEFORE** operating the cooktop burners.

#### Remember:

- Always keep surface burner caps in place whenever using a surface burner.
- When placing the burner caps, be sure that all burner caps are **seated firmly and rest level on top of burner heads**.
- For proper flow of gas and ignition of burners **DO NOT** allow spills, food, cleaning agents or any other material to enter the gas orifice port opening.

#### Round Style Burners

The burner cap ridge (See Fig. 1) should fit snugly into the center of burner head and rest level. Refer to Figs. 2 & 3 for correct and incorrect burner cap placement. Once in place, you may check the fit by gently sliding the burner cap from side to side (Fig. 4) to be sure it is centered and firmly seated. When the burner cap lip makes contact inside the center of the burner head you will be able to hear the burner cap click. Please note that the burner cap **SHOULD NOT** move off the center of the burner head when sliding from side to side.

#### Bridge Style Burners

**Install Burner Caps:** These include one Bridge Burner Center Cap (rectangular shaped) and the two Bridge Burner End Caps (the Bridge Burner End Caps will fit either the front or rear Bridge Burner Head locations). Make sure that the ridges located under the Bridge Burner Caps fall into the slots located in the Bridge Burner Head (see arrows in Figure 5) and that all the Bridge Burner Caps lie flat and evenly on the Bridge Burner Head.

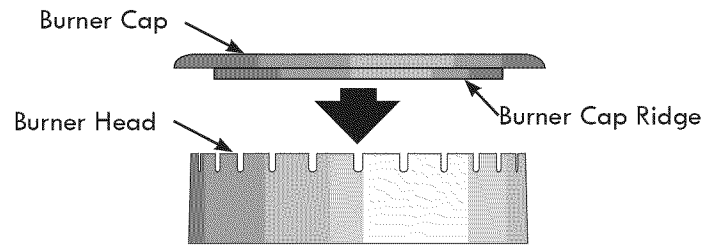
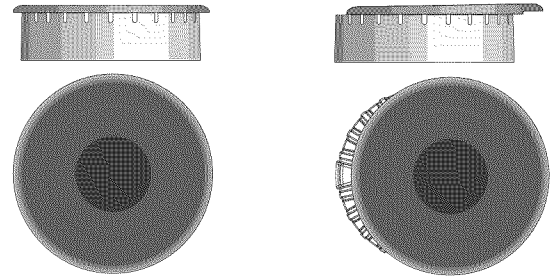

Fig. 1



Correct Burner Cap Placement

Fig. 2

Incorrect Burner Cap Placement

Fig. 3

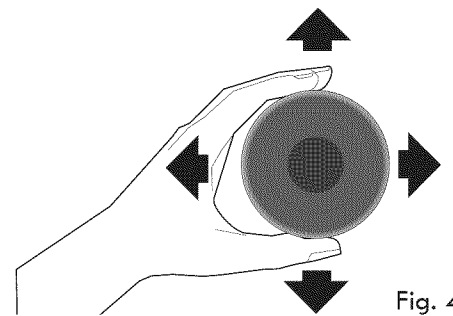

Fig. 4

Fig. 4

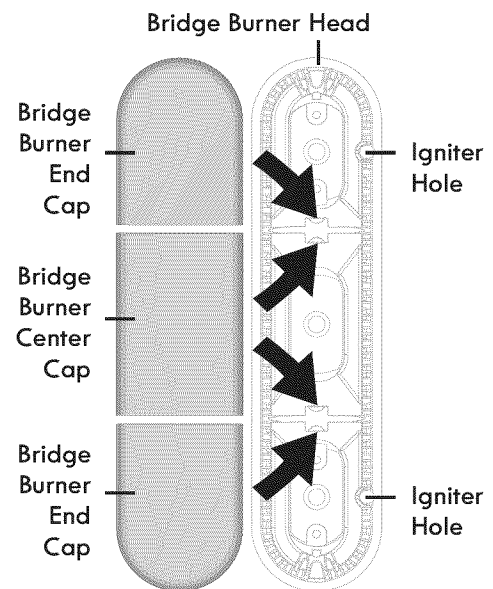

Fig. 5

## Surface Cooking

### Use Proper Cookware

Cookware should have flat bottoms that make good contact with the entire surface heating element. Check for flatness by rotating a ruler across the bottom of the cookware (See Figure 1). Be sure to follow the recommendations for using cookware as shown in Figure 2.

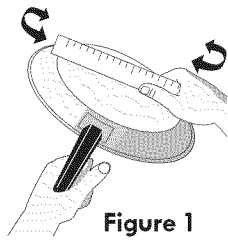
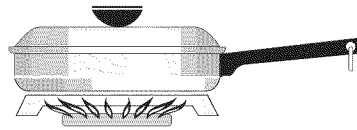

Figure 1

**Note:** The size and type of cookware used will influence the flame setting needed for best cooking results.

**Note:** Always use a utensil for its intended purpose. Follow manufacturer's instructions. Some utensils were not made to be used in the oven or on the cooktop.

### CORRECT



- Flat bottom and straight sides.
- Tight fitting lids.
- Weight of handle does not tilt pan. Pan is well balanced.
- Pan sizes match the amount of food to be prepared.
- Made of material that conducts heat well.
- Easy to clean.

### INCORRECT

- Curved and warped pan bottoms.
- Pan overhangs unit by more than 1" (2.5 cm).

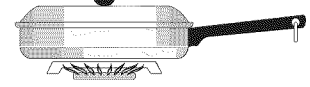
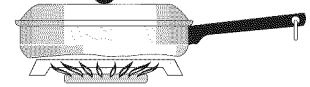

- Heavy handle tilts pan.

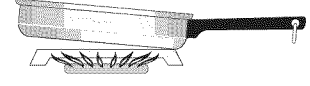

- Flame extends beyond unit.

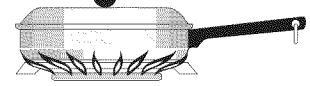
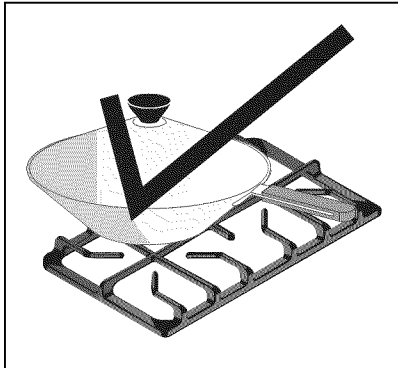

Figure 2

- \* Specialty pans such as lobster pots, griddles and pressure cookers may be used but must conform to the above recommended cookware requirements.

### Using a Wok (not supplied)



Woks with flat bottoms suitable for use on your cooktop are available in most cookshop or hardware stores. Round-bottomed woks (with a support ring that does not extend beyond the burner flames) may also be used. The metal ring was designed to support the wok safely when it is filled with large amounts of liquids (soup making) or fat (frying).

**DO NOT** use a wok if it is equipped with a metal ring that extends beyond the burner flames. Because this ring traps heat, the surface unit and cooktop surface could be damaged.

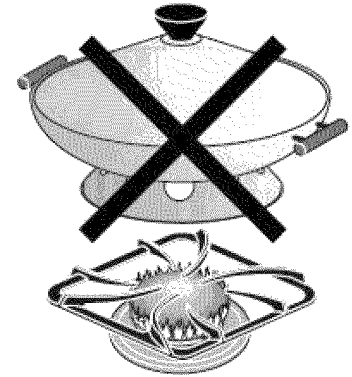

**Wire trivets: DO NOT** use wire trivets. Cookware bottoms must be in direct contact with the grates.

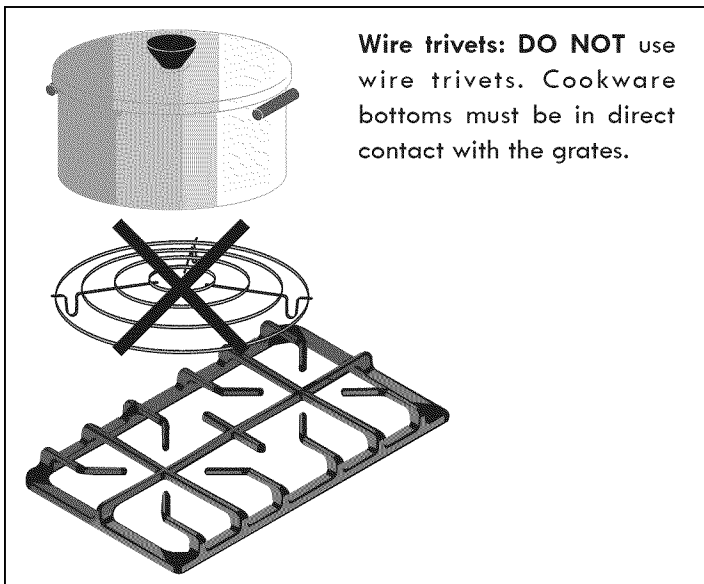



## Setting the Downdraft Vent System

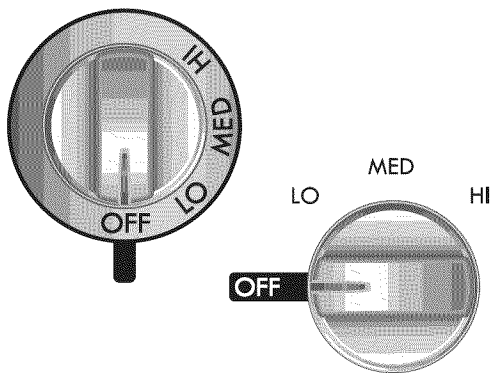

Figure 1

Your appliance is equipped with an integrated downdraft vent system that may be turned on at any moment. This system helps remove smoke, odors and vapors from food prepared on your cooktop.

To activate the downdraft vent system, simply turn the knob to the desired fan power setting.

When you are finished operating the downdraft vent system, turn back the knob to the Off position.

**IMPORTANT:** For best performance, the grease filter must be properly installed and often cleaned. See the "General Care and Cleaning" section for more information.

## Setting Surface Burner Controls

**⚠ CAUTION** DO NOT place plastic items such as salt and pepper shakers, spoon holders or plastic wrappings on top of the range when it is in use. These items could melt or ignite. Potholders, towels or wood spoons could catch fire if placed too close to a flame.

### Manual Lighting

In the event of an electrical power outage, the surface burners can be lit manually. To light a surface burner, hold a lit match to the burner head, then slowly turn the surface control knob to **LITE**. After burner lights, turn knob to desired setting. Use caution when lighting surface burners manually.

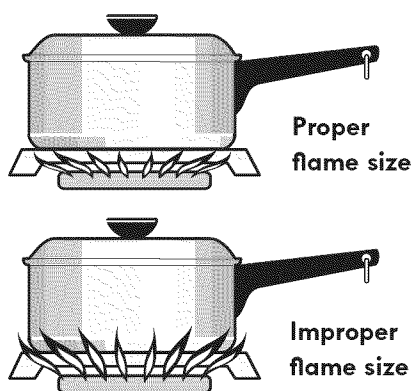

Figure 2

### Setting Proper Surface Burner Flame Size

For most cooking, start on the highest control setting and then turn to a lower one to complete the process. Use the recommendations below as a guide for determining proper flame size for various types of cooking. The size and type of utensil used and the amount of food being cooked will influence the setting needed for cooking.

Flame Size*	Type of Cooking
High Flame	Start most foods; bring water to a boil; pan broiling.
Medium Flame	Maintain a slow boil; thicken sauces, gravies; steaming.
Low Flame	Keep foods cooking; poach; stewing.

\*These settings are based on using medium-weight metal or aluminum pans with lids. Settings may vary when using other types of pans. The color of the flame is the key to proper burner adjustment. A good flame is clear, blue and hardly visible in a well-lighted room. Each cone of flame should be steady and sharp. Clean burner if flame is yellow-orange.

Regardless of size, always select cookware that is suitable for the amount and type of food being prepared. Select a burner and flame size appropriate to the pan. Never allow flames to extend beyond the outer edge of the pan.

**⚠ WARNING** NEVER extend the flame beyond the outer edge of the utensil. A higher flame wastes heat and energy and increases your risk of being burned by the flame (Figure 2).

For deep fat frying, use a thermometer and adjust the surface control knob accordingly. If the fat is too cool, the food will absorb the fat and be greasy. If the fat is too hot, the food will brown so quickly that the center will be undercooked. **DO NOT** attempt to deep fat fry too much food at once as the food will neither brown nor cook properly.

## Setting Surface Burner Controls

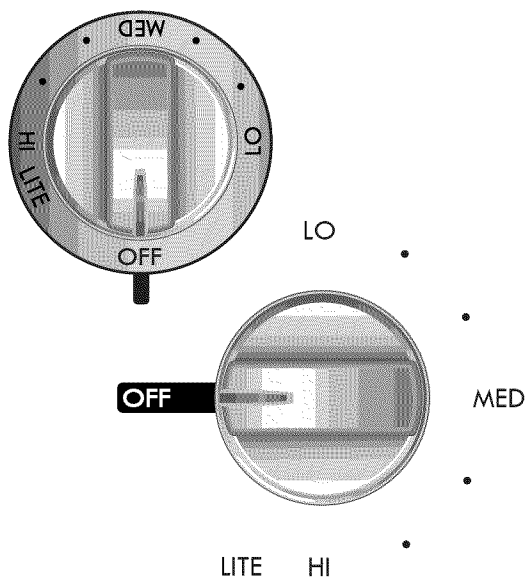
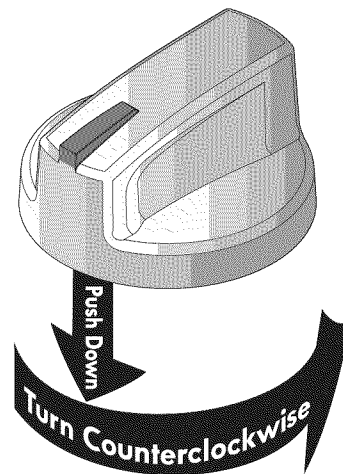

Figure 1 - Regular Burner Knobs

## Setting and Operating the Simmer, Regular, Power, and Turbo Boil Burners

1. Place cooking utensil on surface burner.
2. Push the surface control knob down and turn **counterclockwise** out of the OFF position (See Figure 1).
3. Release the knob and rotate to the LITE position.  
Note: All four (or five) electronic surface ignitors will spark at the same time. However, only the burner you are turning on will ignite.
4. **Visually check that the burner has a flame.**
5. Once the burner is lit, continue to turn **counterclockwise** to the desired flame size. The control knobs **DO NOT** have to be set at a particular setting. Use the knob indicator settings to adjust the flame as needed.

**⚠ CAUTION DO NOT** cook with the surface control knob in the LITE position (the electronic ignitor will continue to spark if the knob is left in the LITE position).



## Setting the Bridge Burner

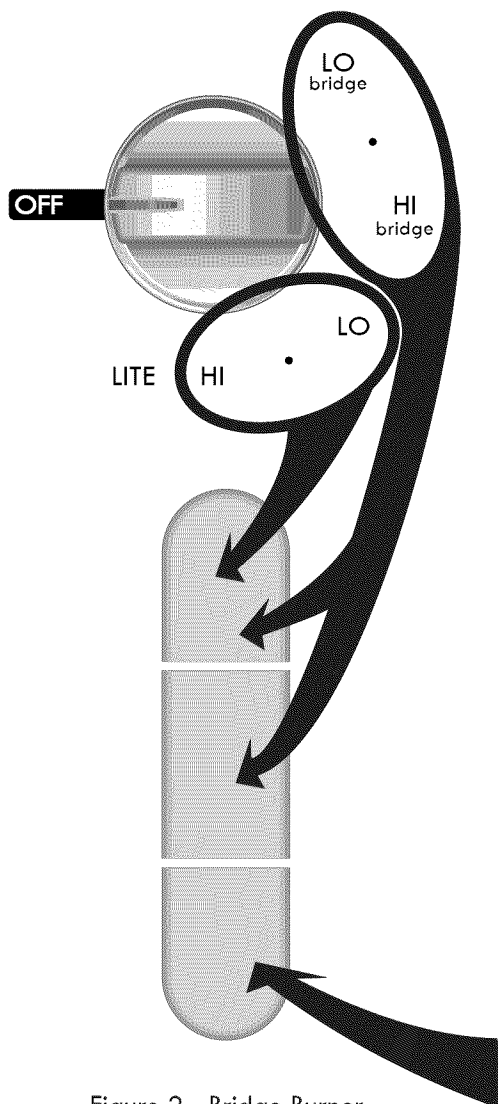

Figure 2 - Bridge Burner

## Setting the Bridge Burner

The Bridge Burner should be used with rectangular shaped cookware. Cookware like a cast-iron Griddle is designed specifically for best results with the Bridge Burner.

The Bridge Burner feature may be used to combine the cooking power of 2 or if needed 3 gas surface Burners located along the left-hand side of the cooktop. The left rear and left center Burners are controlled by the left rear surface Control Knob. In addition the left front Burner may be added to the Bridge Burner with the left front gas Control Knob.

## Operating the Bridge Burner

1. Push the left rear surface control knob in and turn **counterclockwise** out of the OFF position (See Figure 2).
2. Release the knob and rotate to the **LITE** position (See Figure 2). Note: All electronic surface ignitors will spark at the same time. However, only the selected surface Burner will lite.
3. **Visually check that the rear Burner has lit.**
4. Continue to rotate the gas control knob counterclockwise past the first LO.
5. Visually check that both the rear and center Burners are lit.
6. When both Burners are lit, continue to turn the control knob **counterclockwise** to adjust to the desired flame size for both Burners together. Note: The markings between **bridge HI** and **bridge LO** settings on the control knob are used for adjusting the flame size for both burners.
7. Add the front Burner if needed. Once lit, visually adjust the flame size of the front Burner to match the flame size of the center and rear Burners.

**⚠ CAUTION DO NOT** cook with any of the surface control knobs in the LITE position (The electronic ignitor will continue to spark if the knob is left in the LITE position).

**Note:** If only the rear surface Burner is needed, adjust the settings between the first HI and LO.

**Note:** The front Burner may be added as part of the Bridge Burner by setting the left front gas Control Knob.

## General Care & Cleaning

### Cleaning Various Parts of Your Cooktop

Before cleaning any part of the cooktop, be sure all controls are turned OFF and the cooktop is COOL. REMOVE SPILLOVERS AND HEAVY SOILING AS SOON AS POSSIBLE. REGULAR CLEANINGS NOW WILL REDUCE THE DIFFICULTY AND EXTENT OF A MAJOR CLEANING LATER.

Surfaces	How to Clean
Control Knobs	For general cleaning, use hot soapy water and a cloth. For more difficult soils and built-up grease, apply a liquid detergent directly onto the soil. Leave on soil for 30 to 60 minutes. Rinse with a damp cloth and dry. <b>DO NOT</b> use abrasive cleaners on any of these materials; they can scratch or dull the finish.
Control Panel	Wipe the control panel clean after each use. Before cleaning the control panel, turn all controls to OFF and remove the control knobs. To remove, pull each knob straight off the shaft. Clean using hot, soapy water and a cloth. Be sure to squeeze excess water from the cloth before wiping the panel; especially when wiping around the controls. Excess water in or around the controls may cause damage to the appliance. To replace knobs after cleaning, line up the flat sides of both the knob and the shaft; then push the knob into place.
Stainless Steel	Clean with hot, soapy water and a dishcloth. Rinse with clean water and cloth. <b>DO NOT use cleaners with high concentrations of chlorides or chlorines. DO NOT</b> use harsh scrubbing cleaners. Only use kitchen cleaners that are especially made for cleaning stainless steel. Always be sure to rinse the cleaners off from the surface as bluish stains may occur during heating that cannot be removed.
Porcelain Enamel Burner Grates, Cooktop Surface	Gentle scouring with a soapy scouring pad will remove most spots. Rinse with a 1:1 solution of clear water and ammonia. If necessary, cover difficult spots with an ammonia-soaked paper towel for 30 to 40 minutes. Rinse with clean water and a damp cloth, and then scrub with a soap-filled scouring pad. Rinse and wipe dry with a clean cloth or paper towel. Remove all cleaners or the porcelain may become damaged during future heating. <b>DO NOT</b> use spray oven cleaners on the cooktop.
Grease Filter	For general cleaning, the grease filter can be cleaned in the dishwasher.
Grate Seal	Clean with a mild solution of soap and warm water. Rinse clean and dry before use. The grate seal may be cleaned in a dishwasher, TOP RACK ONLY.

### Porcelain Enamel Cooktop Cleaning Instructions (some models)

The cooktop is designed to make cleaning easier. Because the gas burner are sealed, cleanups are easy when spillovers are cleaned up immediately. Correct and consistent cleaning is essential to maintaining your porcelain enamel cooktop. If food spills and grease spatters are not removed, they may burn onto the surface of the cooktop and cause permanent discoloration.

**⚠ CAUTION DO NOT** remove any parts from the cooktop until they have completely cooled and are safe to handle.

#### Daily Cleaning

##### For normal soil:

1. Allow cooktop surface to cool.
2. Wipe off spills and spatters using a clean paper towel or a clean cloth with warm, soapy water.
3. If needed, use mild household cleaners or a soap-filled steel wool pad.
4. Be sure to rinse off all cleaning solutions or the porcelain may become damaged during future heating.

##### For heavy, burned-on soil:

1. Allow cooktop surface to cool.
2. Use a soap filled scouring pad with warm water or cover heavily soiled spots with a solution of clear water and ammonia. Scour gently. Rinse and wipe dry with a clean cloth.

**DO NOT use harsh abrasive cleaners on the cooktop. They can scratch the stainless steel / porcelain.**

**⚠ WARNING DO NOT** use a cooktop cleaner on a hot cooktop. The fumes can be hazardous to your health, and can chemically damage the cooking surface.

**⚠ CAUTION** Before cleaning the surface cooktop, be sure the controls are turned to OFF and the cooktop is cool.

**⚠ WARNING DO NOT** use commercial oven cleaners on the cooktop

## General Care & Cleaning

### Cleaning the Burner Grates

The burner grates are dishwasher safe and may be cleaned in the dishwasher. Remove any excessive soils before placing in the dishwasher.

#### IMPORTANT

- For proper gas flow and ignition of the burners — **DO NOT** allow spills, food, cleaning agents or any other material to enter the gas orifice opening.
- The cooktop is not removable. **DO NOT** attempt to remove or lift the cooktop.

**CAUTION** To avoid possible burns use care when cleaning the cooktop, **DO NOT** attempt to clean the cooktop whenever the cooktop or burner heads are still hot.

**CAUTION** To avoid possible burns **DO NOT** attempt any of the following cleaning instructions provided before turning OFF all of the surface burners and allow them to cool.

**CAUTION** To avoid possible burns **DO NOT** attempt to operate the surface burners without the burner caps

Before using your gas appliance be sure to:

- Follow installation instructions before operating.
- Remove all packing tape from cooktop area.
- Properly install the Bridge Burner and burner caps (See page 7).

### Cleaning the Burner Caps

Should you ever need to remove the burner caps for cleaning, lift the burner cap off the burner head. Clean heavy soils with an absorbent cloth. Rinse with a clean, damp cloth and immediately thoroughly dry including the bottom and inside of the cap. **DO NOT** use harsh abrasive cleaners. They can scratch the porcelain on the cap. **DO NOT** clean burner caps in dishwasher.

**IMPORTANT** - When placing the burner caps on the cooktop, be sure the burner caps are seated firmly on top of burner heads. Improper flame size and uneven heating may result when any surface burners are turned ON and the burner caps are not seated correctly.

### Cleaning the Burner Heads

Lift the burner cap from the burner head. The surface burner heads are secured to the cooktop and must be cleaned in place (except for the Bridge Burner, which is removable. See Bridge Style Burners section for proper installation).

For proper gas flow it may be necessary to clean the burner heads and slots. To clean, first use a clean DAMP cloth to soak up any spills. Remove any food from between the burner slots using a small nonabrasive brush like a toothbrush and afterwards wipe using a damp cloth. For stubborn soils

located in the slots, use a small-gauge wire or needle to clean.

Should you experience ignition problems it may be that an ignition port hole is partially blocked with soil (see Fig. 1).

With the burner head in place, use a small wire gauge needle or the end of a paper clip to clear the ignition port or ports.

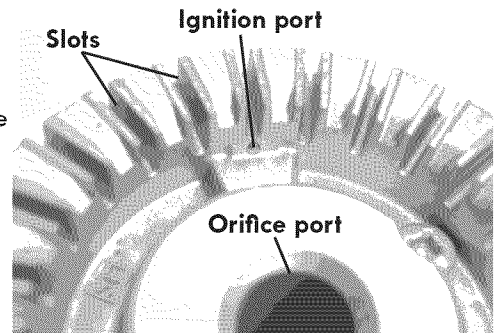

Figure 1- Cooktop regular burner head

### Downdraft Vent System

**CAUTION** Be sure to turn off the downdraft vent system before cleaning any of its parts.

**CAUTION** To avoid possible burns use care when cleaning the downdraft system, **DO NOT** attempt to clean the cooktop whenever the grates are still hot.

### Cleaning the Vent Grate

Remove the vent grate (Fig. 2) from the cooktop by lifting it off. The vent grate is dishwasher safe and may be cleaned in the dishwasher. Remove any excessive soils before placing in the dishwasher. Use mild detergent.

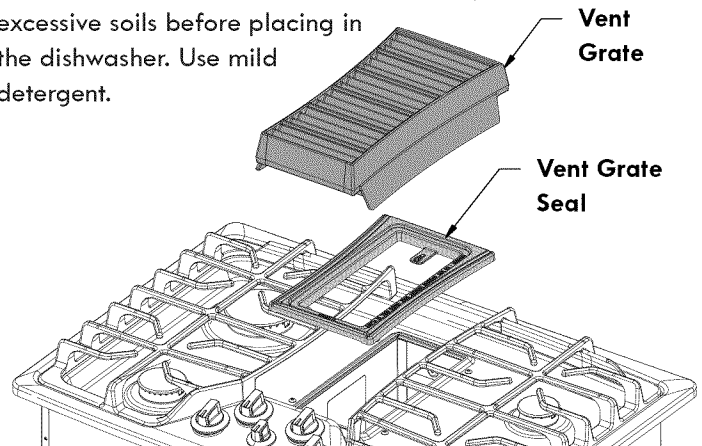

Figure 2A - 30" Model

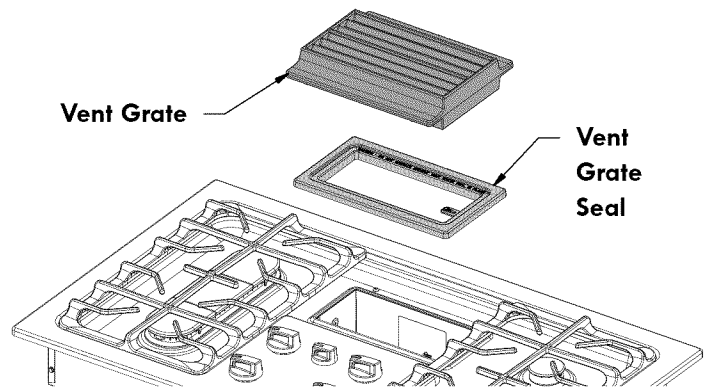

Figure 2B - 36" Model

## General Care & Cleaning

### Cleaning the Vent Grate Seal

Remove the vent grate seal from the cooktop by removing the 1/4" hex head screw holding the seal to the inside of the vent (Fig. 1) and then lifting the seal off. The vent grate seal can be cleaned using warm soapy water and may be cleaned in the dishwasher, TOP RACK ONLY. Remove any excessive soils before placing in the dishwasher. Use mild detergent.

**CAUTION** After cleaning the vent grate seal, make sure the vent grate seal is properly reinstalled in the cooktop as shown in Figures 1A - 1B. Make sure the collar is fully inserted into the vent opening. Fasten the tab on the vent grate seal to the vent with the 1/4" hex head screw.

Before placing the grate on the vent grate seal, press down on the four corners to seat the seal in place.

**DO NOT** operate the downdraft vent system without the vent grate seal in place.

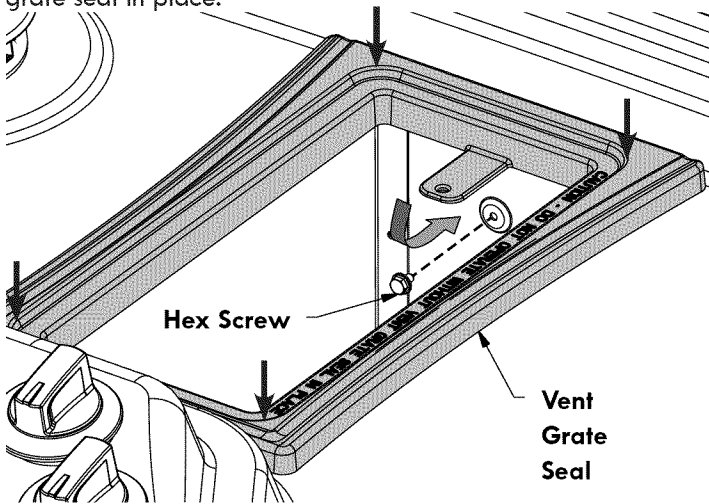

Figure 1A - 30" Model

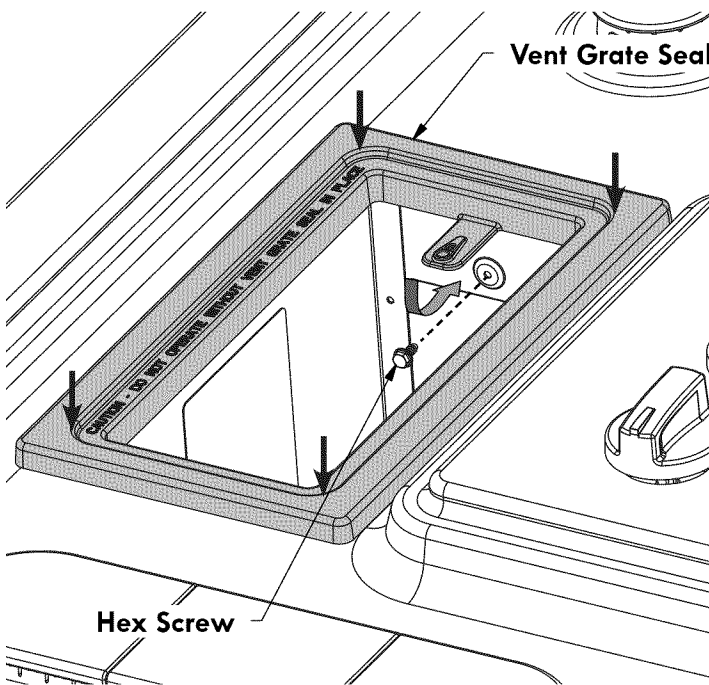

Figure 1B - 36" Model

### Cleaning the Grease Filter

Remove the grease filter (Fig. 2) from the vent chamber by lifting it out. The grease filter can be cleaned using hot soapy water. Rinse with clean water and dry thoroughly. The grease filter is dishwasher safe. When cleaned, replace the filter **diagonally** in the vent chamber as shown on Figure 3.

**CAUTION** DO NOT operate the downdraft vent system without the filter in place.

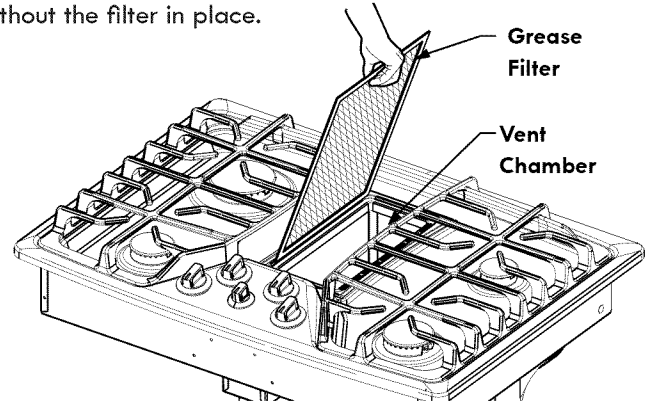

Figure 2A - 30" Model

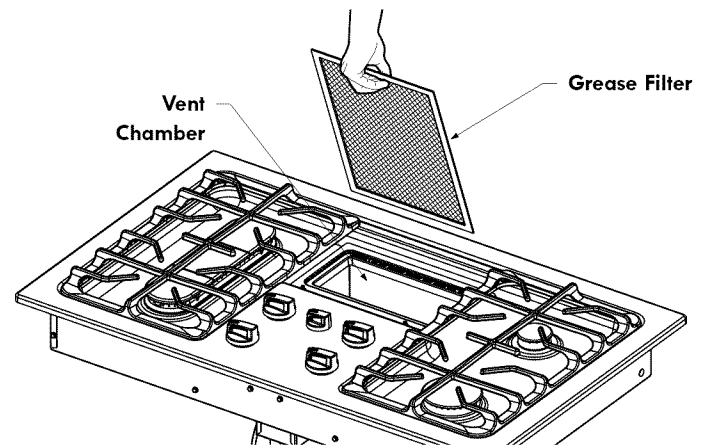

Figure 2B - 36" Model

### Cleaning the vent chamber

Use a cloth with hot soapy (mild detergent) water to clean the chamber. Rinse with clean water and dry thoroughly.

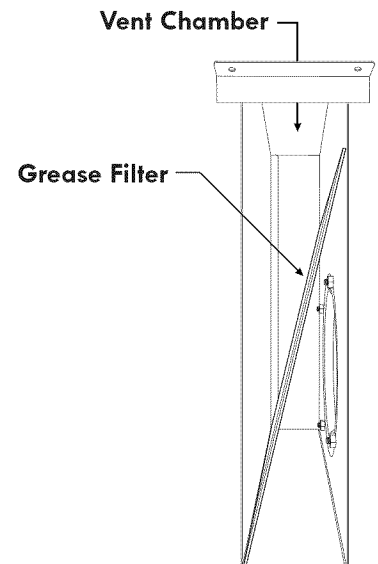

Figure 3

# Before You Call

## Solutions to Common Problems

Before you call for service, review this list. It may save you time and expense. The list includes common occurrences that are not the result of defective workmanship or materials in this appliance.

<b>OCCURRENCE</b>	<b>POSSIBLE CAUSE/SOLUTION</b>
<b>Surface burners DO NOT light.</b>	Surface Control knob has not been completely turned to LITE. Push in and turn the Surface Control knob to LITE until burner ignites and then turn control to desired flame size. Be sure gas supply valve is open. Burner ports or slots are clogged. With the burner off, use a small-gauge wire or needle to clean ports or slots. Power cord is disconnected from outlet (electric ignition models). Be sure cord is plugged securely into outlet. Electrical power outage (electric ignition models). Burners can be lit manually. See <b>Setting Surface Controls</b> in this Use & Care Guide.
<b>Surface burner flame burns half way around.</b>	Burner ports or slots are clogged. With the burner off, clean ports with a small-gauge wire or needle to clean ports or slots. Moisture is present after cleaning. Lightly fan the flame and allow burner to operate until flame is full. To avoid this occurrence dry the burners thoroughly following instructions under <b>General Care &amp; Cleaning</b> .
<b>Surface burner flame is orange.</b>	Dust particles in main line. Allow the burner to operate a few minutes until flame turns blue. In coastal areas, a slightly orange flame is unavoidable due to salt air.
<b>Surface burner flame is too high or too low.</b>	Surface burner valves are not adjusted properly. Refer to your LP conversion instructions for guidance on how to adjust the valves.
<b>Blower motor not running</b>	No power to the appliance. Check steps under "Entire Cooktop Does Not Operate" in this Before You Call checklist
<b>Reduced performance of the ventilation system</b>	Check that grease filter has been properly cleaned and installed. Check that no foreign objects are present in the ventilation chamber. Check that the proper control setting is selected to match the cooking conditions on the cooktop.
<b>Rattling noise during ventilation operation</b>	Verify that the mounting nuts on the blower housing have been properly tightened. Verify that the external ductwork has been mounted and secured properly. Verify that there are no foreign objects in the external ductwork.
<b>Reduced performance of the ventilation system.</b>	Verify that the vent grate seal and vent grate have been properly installed on the cooktop.
<b>Surface burner flame extinguishes when ventilation system is ON.</b>	Verify that the vent grate seal and vent grate have been properly installed on the cooktop.
<b>Entire Cooktop Does Not Operate</b>	No power to the appliance. Check that power cord is plugged securely into outlet. Check that the circuit breaker or fuse for the outlet is intact.

# MASTER PROTECTION AGREEMENTS

*Congratulations on making a smart purchase.* Your new Kenmore® product is designed and manufactured for years of dependable operation. But like all products, it may require preventive maintenance or repair from time to time. That's when having a Master Protection Agreement can save you money and aggravation.

The Master Protection Agreement also helps extend the life of your new product. Here's what the Agreement\* includes:

- ☑ **Parts and labor** needed to help keep products operating properly **under normal use**, not just defects. Our coverage goes **well beyond the product warranty**. No deductibles, no functional failure excluded from coverage – **real protection**.
- ☑ **Expert service** by a force of more than **10,000 authorized Sears service technicians**, which means someone you can trust will be working on your product.
- ☑ **Unlimited service calls and nationwide service**, as often as you want us, whenever you want us.
- ☑ **«No-lemon» guarantee** – replacement of your covered product if four or more product failures occur within twelve months.
- ☑ **Product replacement** if your covered product can't be fixed.
- ☑ **Annual Preventive Maintenance Check** at your request – no extra charge.
- ☑ **Fast help by phone** – we call it **Rapid Resolution** – phone support from a Sears representative on all products. Think of us as a «talking owner's manual».
- ☑ **Power surge protection** against electrical damage due to power fluctuations.
- ☑ **\$250 Food Loss Protection** annually for any food spoilage that is the result of mechanical failure of any covered refrigerator or freezer.
- ☑ **Rental reimbursement** if repair of your covered product takes longer than promised.
- ☑ **25% discount** off the regular price of any non-covered repair service and related installed parts.

Once you purchase the Agreement, a simple phone call is all that it takes for you to schedule service. You can call anytime day or night, or schedule a service appointment online.

The Master Protection Agreement is a risk free purchase. If you cancel for any reason during the product warranty period, we will provide a full refund. Or, a prorated refund anytime after the product warranty period expires. Purchase your Master Protection Agreement today!

**Some limitations and exclusions apply. For prices and additional information in the U.S.A. call 1-800-827-6655.**

**\* Coverage in Canada varies on some items. For full details call Sears Canada at 1-800-361-6665.**

## **Sears Installation Service**

*For Sears professional installation* of home appliances, garage door openers, water heaters, and other major home items, in the U.S.A. or Canada call **1-800-4-MY-HOME®**.

# Get it fixed, at your home or ours!

## Your Home

For troubleshooting, product manuals and expert advice:



[www.managemylife.com](http://www.managemylife.com)

For repair – **in your home** – of **all** major brand appliances, lawn and garden equipment, or heating and cooling systems, **no matter who made it, no matter who sold it!**

For the replacement parts, accessories and owner's manuals that you need to do-it-yourself.

For Sears professional installation of home appliances and items like garage door openers and water heaters.

**1-800-4-MY-HOME<sup>®</sup>** (1-800-469-4663)

Call anytime, day or night (U.S.A. and Canada)

[www.sears.com](http://www.sears.com)      [www.sears.ca](http://www.sears.ca)

## Our Home

For repair of carry-in items like vacuums, lawn equipment, and electronics, call anytime for the location of your nearest

**Sears Parts & Repair Service Center**

**1-800-488-1222** (U.S.A.)

[www.sears.com](http://www.sears.com)

**1-800-469-4663** (Canada)

[www.sears.ca](http://www.sears.ca)

To purchase a protection agreement on a product serviced by Sears:

**1-800-827-6655** (U.S.A.)

**1-800-361-6665** (Canada)

Para pedir servicio de reparación a domicilio, y para ordenar piezas:

**1-888-SU-HOGAR<sup>®</sup>**

(1-888-784-6427)

[www.sears.com](http://www.sears.com)

Au Canada pour service en français:

**1-800-LE-FOYER<sup>MC</sup>**

(1-800-533-6937)

[www.sears.ca](http://www.sears.ca)

The Sears logo, consisting of the word "sears" in a lowercase, serif font.

® Registered Trademark / <sup>TM</sup> Trademark of KCD IP, LLC in the United States, or Sears Brands, LLC in other countries

® Marca Registrada / <sup>TM</sup> Marca de Fábrica de KCD IP, LLC en Estados Unidos, o Sears Brands, LLC in otros países

<sup>MC</sup> Marque de commerce / <sup>MD</sup> Marque déposée de Sears Brands, LLC