



Earn BISSELL Rewards!

Register your product today!
See details on back page

TRilogy™
3 WAYS TO CLEAN

TRilogy™
3 WAYS TO CLEAN
pet

TRIPLEclean
PROFESSIONAL™

USER'S GUIDE
81M9 SERIES

- 2 Thank You
- 3 Safety Instructions
- 4 Product View
- 5-6 Assembly
- 6-9 Operations
- 10-15 Maintenance and Care
- 16-17 Troubleshooting
- 18 Replacement Parts
- 18 Accessories
- 19 Warranty
- 20 Product Registration
- 20 Consumer Care





Thanks for buying a BISSELL vacuum

We're glad you purchased a BISSELL vacuum. Everything we know about floor care went into the design and construction of this complete, high-tech home cleaning system.

Your BISSELL vacuum is well made, and we back it with a limited three year warranty. We also stand behind it with a knowledgeable, dedicated Consumer Care department, so, should you ever have a problem, you'll receive fast, considerate assistance.

My great-grandfather invented the floor sweeper in 1876. Today, BISSELL is a global leader in the design, manufacture, and service of high quality homecare products like your BISSELL vacuum.

Thanks again, from all of us at BISSELL.

Mark J. Bissell
Chairman & CEO



IMPORTANT SAFETY INSTRUCTIONS

When using an electrical appliance, basic precautions should be observed, including the following:

READ ALL INSTRUCTIONS BEFORE USING YOUR UPRIGHT VACUUM.

Always connect to a polarized outlet (left slot is wider than right). Unplug from outlet when not in use and before conducting maintenance.

⚠ WARNING: To reduce the risk of fire, electric shock, or injury:

- Do not modify the polarized plug to fit a non-polarized outlet or extension cord.
- Do not leave vacuum cleaner unattended when it is plugged in.
- Unplug from outlet when not in use and before servicing.
- Do not use outdoors or on wet surfaces.
- Do not allow children to operate vacuum cleaner or use as a toy.
- Close attention is necessary when used by or near children.
- Do not use for any purpose other than described in this user's guide.
- Use only manufacturer's recommended attachments.
- Do not use with damaged cord or plug.
- If appliance is not working as it should, has been dropped, damaged, left outdoors, or dropped into water, have it repaired at an authorized service center.
- Do not pull or carry by cord, use cord as a handle, close a door on cord, or pull cord around sharp edges or corners. Do not run appliance over cord. Keep cord away from heated surfaces.
- Do not unplug by pulling on cord. To unplug, grasp the plug, not the cord.
- Do not handle vacuum cleaner or plug with wet hands.
- Do not put any object into openings. Do not use with any opening blocked; keep openings free of dust, lint, hair, and anything that may reduce air flow.
- Keep hair, loose clothing, fingers, and all parts of body away from openings and moving parts.

- Turn off all controls before plugging or unplugging vacuum cleaner.
- Use extra care when cleaning stairs.
- Unplug before attaching the TurboBrush® Tool.
- Do not pick up flammable materials (lighter fluid, gasoline, kerosene, etc.) or use in the presence of explosive liquids or vapors.
- Do not pick up toxic material (chlorine bleach, ammonia, drain cleaner, etc.).
- Do not use vacuum cleaner in an enclosed space filled with vapors given off by oil base paint, paint thinner, some moth proofing substances, flammable dust, or other explosive or toxic vapors.
- Do not pick up hard or sharp objects such as glass, nails, screws, coins, etc.
- Do not pick up anything that is burning or smoking, such as cigarettes, matches, or hot ashes.
- Do not use without filters in place.
- Use only on dry, indoor surfaces.
- Keep appliance on a level surface.
- Do not carry the vacuum cleaner while it is running.
- Brush may unexpectedly restart. Unplug from outlet when cleaning or servicing
- Allow carpet cleaning solution to dry completely before vacuuming.

SAVE THESE INSTRUCTIONS FOR FUTURE USE

THIS APPLIANCE HAS A POLARIZED PLUG.

To reduce the risk of electric shock, this appliance has a polarized plug (one blade is wider than the other). This plug will fit in a polarized outlet only one way. If the plug does not fit fully in the outlet, reverse the plug. If it still does not fit, contact a qualified electrician to install a proper outlet. Do not change the plug in any way.

This model is for household use only.

Product view

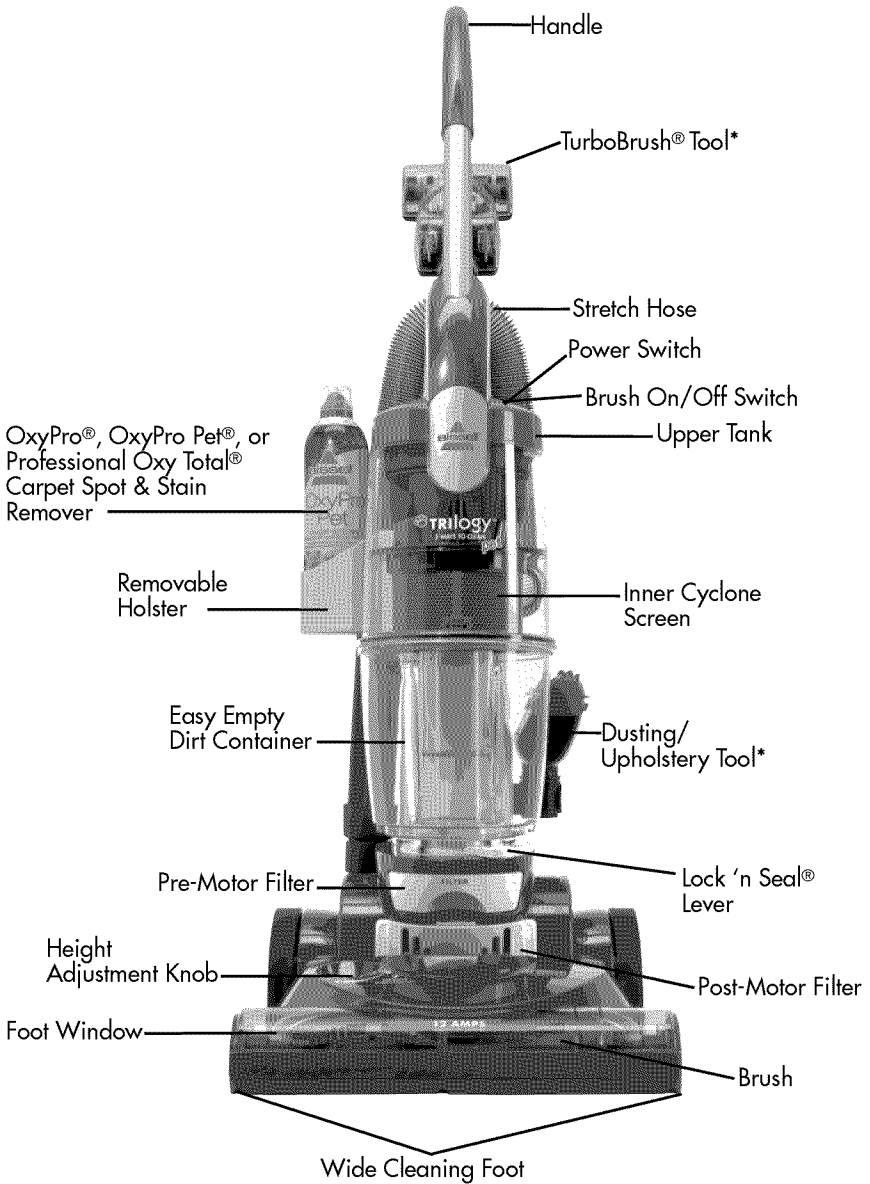

*Accessories may vary

Assembly

Tools needed: Philips head screwdriver.

Attach handle to vacuum

1. Locate vacuum handle and the bag that contains extension wand support, lower cord wrap, and screws.
2. Stand vacuum upright and from the back of the vacuum, slide the base of the handle firmly into the grooves at the top of the vacuum body. Continue to push so there are no gaps and the front of the handle is flush with front of the vacuum body.
3. Insert two of the four screws provided into the existing holes and tighten with screw driver to fasten handle to vacuum body.

Attach storage clips, tool, and vacuum hose

1. Locate the bag that contains extension wand support, lower cord wrap, and remaining two screws.
2. Attach extension wand support half way down on the back of the vacuum body. Insert one screw and tighten with screwdriver.
3. Attach lower cord wrap to back of the vacuum (position toward bottom of vacuum body). Insert remaining screw and tighten securely with screwdriver.
4. Attach Twist 'n Snap™ hose by lining up the tabbed end of the hose into the opening by the clear tank on the back of the vacuum. Twist to the right to lock into place.
5. Insert opposite hose end base into suction inlet on the side of vacuum near the wheel.

NOTE: The vacuum will not operate effectively unless the hose is firmly attached.

6. Store crevice tool into the extension wand and snap into extension wand support on the back of the vacuum.
7. Slide dusting brush into the storage clip on the right side of vacuum (when viewing from front). Model 81M9-1 comes with Pet Contour tool® that stores in same place.
8. Store TurboBrush® Tool in the hole marked "tool" on the top of the handle arch.

NOTE: Model 81M9-1 comes with Pet TurboBrush® Tool.

⚠ WARNING:

Do not plug in your vacuum cleaner until you are familiar with all instructions and operating procedures.

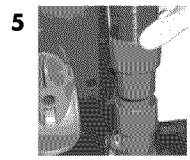
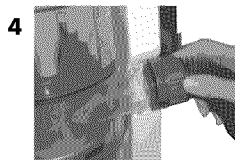
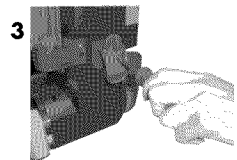
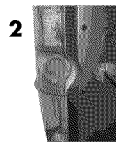
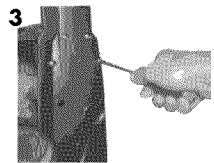
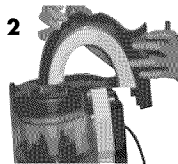

Assembly

Attach carpet spot & stain remover Pet holster

1. Locate the bag that contains carpet spot & stain remover holster and can.
2. Attach holster to left side of vacuum (when viewing from front) by lining up the two tabs on the back side of the holster with the two openings on the vacuum. Push holster down to lock into place.
3. Place provided can of carpet spot & stain remover* into holster. Follow instructions on page 8 for carpet spot & stain remover.*

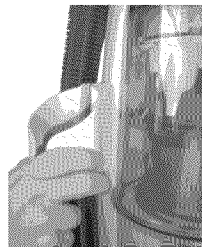

Operations

Power cord

To store power cord, wrap cord around upper cord wrap and lower extension wand support. Use clip on the end of the plug to attach plug to the cord.

To release power cord, rotate the upper cord wrap down and gently pull off cord.

Power switch

The power button is located just below the handle on the right side of the vacuum when viewing from the front. "ON" (I) "OFF" (O).

NOTE: Rotating brush will not turn on unless the unit is in reclined position and brush switch is on.

Brush ON/OFF switch

Brush ON/OFF is located just below the handle on the right side of the vacuum when viewing from the front. Push the rocker switch ON- (I) to turn brush on for most carpeted surfaces, when "ON" the brush will start rotating when unit is in reclined position. Push rocker switch OFF - (O) to turn brush off for bare floor cleaning or other delicate surfaces.

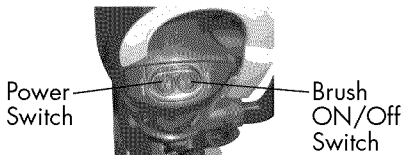
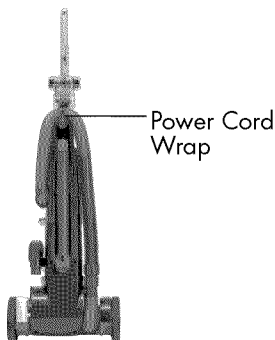

ATTENTION:

Some frieze carpets have long delicate fibers or threads that may be damaged by the rotating brush during vacuuming. It is recommended the rotating brush be turned OFF when cleaning this type of carpet.

* Carpet spot & stain remover varies by model. Refer to page 4.

Operations

Handle positions

1. In upright position, tilt cleaner back on its rear wheels to transport from room to room. The vacuum can also be moved by using the carrying handle on front of the vacuum.
2. Using your foot, press handle release pedal on the lower left side of the vacuum to recline vacuum in cleaning position.

NOTE: The brush will only rotate when vacuum is in reclined cleaning position, it will not rotate when in upright position.

Height adjustments

Turn Dial on Powerfoot to adjust to one of 7 Height Adjustments:

Lowest setting – for low pile carpet or bare floors.

Medium settings – for medium pile carpet.

High setting – For high pile and most shag carpet. Adjust to high setting if difficult to push.

NOTE: For optimal carpet cleaning performance adjust to lowest practical setting. If your vacuum is difficult to push, adjust to the next higher setting.

If the dial is difficult to turn, tilt the cleaner back slightly to take the weight off of the foot while turning.

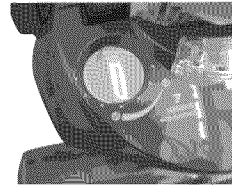
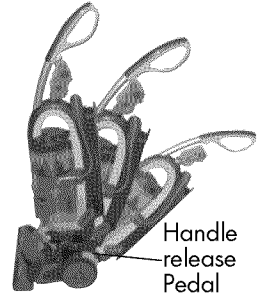
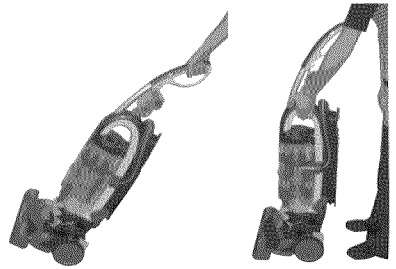

ATTENTION:

Some Berber carpets have a tendency to fuzz with wear. Repeated strokes in the same area may aggravate this condition. Consider setting your cleaner on a higher than normal setting for this type of carpet.

NOTICE:

While vacuuming, certain carpets and low humidity conditions may generate small static discharges. The discharges are entirely harmless and are not associated in any way with the main power supply.

Using BISSELL Pet Carpet Spot & Stain Remover*

Your new vacuum comes with BISSELL OxyPro®, OxyPro® Pet, or Professional Oxy Total®, which remove tough stains and odors from carpet. These items are available for purchase by visiting the BISSELL website www.bissell.com.

Read instructions on spot & stain remover can before using, including testing for colorfastness.

How to use

For best results: treat stains immediately. Stains allowed to dry and set can cause bleaching and may be difficult to remove. Before cleaning, remove excess liquid or solid particles from stain.

1. With vacuum in upright position, remove can from holster.
2. Fully depress spray nozzle on top of carpet spot & stain remover and spray in circular pattern, completely covering stain.
3. Allow cleaner to work for 5 minutes.

NOTE: You may continue to vacuum other areas while spot is being treated.

4. Blot with a clean, white absorbent cloth. Once the heavier liquid is picked up and the carpet cleaning solution is completely dry, you may vacuum over the area.

NOTE: Keep children and pets away from area until dry and vacuumed.

NOTICE:

Test stain remover in conspicuous area prior to applying to stain to test for colorfastness.

* Carpet spot & stain remover varies by model. Refer to page 4.

Operations

Using the tools

Attach desired tool to hose for above floor cleaning surfaces or hard to reach areas.

1. Remove Hose: With vacuum in upright position, remove hose end from the suction inlet near the bottom of the vacuum by the wheel. Do not remove "tabbed" end of hose connected to the clear tank.
 2. Attach tools by firmly pushing onto vacuum hose or extension wand.
 - 2a. Dusting brush: Use brush side to dust furniture, blinds, lamps, shelves, and baseboards. 81M9 model only.
 - 2b. Crevice Tool: Use in tight narrow spaces
 - 2c. Extension Wand: Use with desired attachment for longer reach.
 - 2d. TurboBrush[®] Tool: Use rotation brush action for small flat areas such as stairs, and furniture. Press gently down and pull towards you in raking motion, too much pressure will cause brush to stop rotating.
- NOTE: Model 81M9-1 comes with the Pet TurboBrush[®] Tool and follows same operation instructions.**
- 2e. Pet Contour Tool[®] (Included with 81M9-1 only): Use to reach into corners and edges on stairs as well as armrests and other curved surfaces. The tool can be flipped to use in any direction.

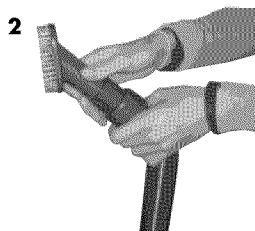

a.



b.



c.



d.



e.



Maintenance and care

To maximize performance and extend life of your vacuum it is very important to perform the following maintenance steps.

Empty dirty container

Empty when dirt reaches the "Full" line on the container

1. Turn power OFF. Unplug power cord from electrical outlet.
2. Slide Lock 'n Seal lever left to "Unlock" position.
3. Grasp dirt cup portion handle and pull straight out to remove from vacuum and empty.
4. Place dirt container back in the vacuum and slide lever right to lock position.

NOTE: The dirt container may be washed in warm water with mild detergent. Make sure it is completely dry before replacing.

2

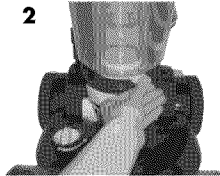

3

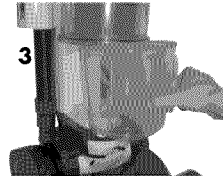

Cleaning upper tank of dirt container

1. Turn Power OFF. Unplug power cord from electrical outlet.
2. Remove and Empty Dirt Container as instructed in previous section.
3. With dirt container removed, grasp inner cyclone screen and twist counterclockwise until the locking tabs stop the rotation. Gently pull the inner cyclone screen down and out to remove it.
4. Clean inner cyclone screen with a damp cloth or mild cleaning solution. Let screen completely dry before replacing.
5. Wipe out the inside of the upper tank and inner cyclone with a damp cloth.

NOTE: Let completely dry before reassembling inner cyclone screen.

6. To reassemble, line up the inner cyclone screen inside the upper tank with "FRONT" graphic facing you, slide into upper cyclone and rotate clockwise until the locking tabs stop the rotation. When properly assembled the "FRONT" graphic should face out.

3

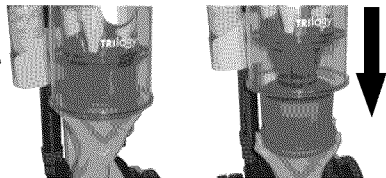

6

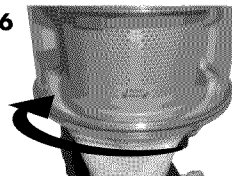

Maintenance and care

Cleaning the pre-motor filter

Check pre-motor filter and wash as needed based on frequency of cleaning.

1. Turn power OFF. Unplug power cord from electrical outlet.
2. The pre-motor filter protects motor from debris and is located in the slide out tray underneath the dirt container. If filter becomes dirty, pull out the tray, lift out the foam filter pad to clean.

NOTE: The pre-motor filter may be hand washed in cold water with mild detergent. Rinse well and dry completely before replacing.

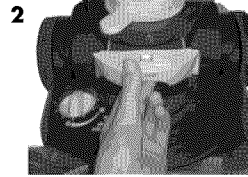

Replacing the post-motor filter cartridge

1. Turn power OFF. Unplug power cord from electrical outlet.
2. The post-motor filter assists in the filtration process to return clean air to the room. It is located under the pre-motor filter tray. The vacuum must be in reclined position to remove the filter.
3. Using your foot, press the handle release pedal and tilt vacuum handle back to a 60 degree angle. Push the button on the top of post-motor filter door to unlatch and remove the door.*
4. If the post-motor filter is dirty, remove and replace it. The white, pleated post-motor filter is NOT washable and must be replaced.*
5. Replace the filter door before returning vacuum back to upright position.

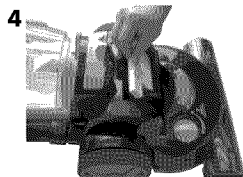
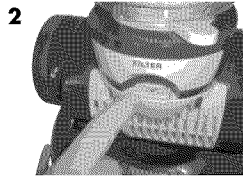

*product images may differ from consumers' models.

Maintenance and care

Check rotating floor brush and drive belt

It is recommended to check your vacuum's rotating floor brush and drive belt regularly for wear or damage.

1. Turn power OFF. Unplug power cord from electrical outlet.
2. Place handle in low cleaning position turn vacuum over so bottom side is facing up.
3. Remove the six screws on the sole plate with Phillips head screwdriver and lift brush cover off.
4. Grasp the rotating floor brush at both ends and lift out .
5. Clean hair, strings, and other debris from rotating brush, motor pulley, and drive belt areas.
6. Check air passageway for obstructions, remove any debris from this area.
7. Check drive belt carefully for wear, cuts, or stressed areas. If any damage is present, discard old drive and replace as instructed in following section.

3

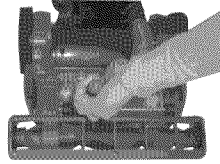

4

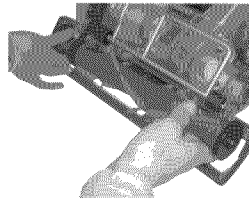

Replace drive belt

1. Turn power OFF. Unplug power cord from electrical outlet.
2. With rotating floor brush removed from vacuum (steps 1-3 in previous section), grasp old drive belt and remove from motor pulley and around floor brush. Discard old drive belt.
3. Place new drive belt over motor pulley and stretch other end over rotating floor brush in the space between the bristles.
4. Place ends of rotating brush back down into slots on sides of vacuum.
5. Turn floor brush by hand several times in the direction of motor pulley. If properly installed, drive belt should center itself on rotating brush.
6. Reposition brush cover and tighten securely with the six screws.

2

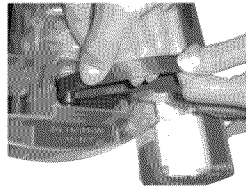

3

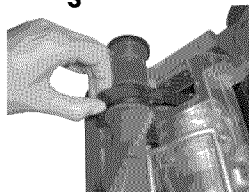

Maintenance and care

Brush reset feature

If an object becomes lodged in the foot and brush shuts off, turn the vacuum off and unplug from electrical outlet. Remove the obstruction and the brush will automatically reset when the vacuum is plugged and turned back on.

Thermal motor protection

An internal thermal protector has been designed into your cleaner to protect it from overheating. When the thermal protector activates, the main vacuum motor will stop operating. If this happens, proceed as follows.

1. Turn the cleaner OFF and unplug from electrical outlet.
2. Check the cleaner for the source of overheating problem (i.e. full dirt cup, dirty filters or clog).
3. Fix the problem by following the steps in the maintenance section of the user guide.
4. When the motor cools for approximately 30 minutes, the thermal protector automatically resets and cleaning may continue. If the cleaner will not turn on or the thermal protector continues to activate, your cleaner may need servicing. Call BISSELL Consumer Care or visit the website to locate an authorized Service Center.

NOTE: The thermal protector controls the main vacuum motor only, not the brush motor. If the thermal protector activates, the brush will continue to operate normally; however, there will be no suction.

Maintenance and care

Clearing clogs

Low suction or poor pickup may be due to a clog in the vacuum. If you notice a change in the sound of the vacuum motor, check for clogs.

1. Turn power OFF. Unplug power cord from electrical outlet.
2. Empty Dirt Container and check upper tank for build up or clogs. If you notice a clog in the upper tank, remove the inner cyclone screen as instructed on page 10.
3. Check the pre-motor filter and clean as necessary as instructed in Cleaning Pre-Motor Filter section.
4. Check the post-motor filter and replace if necessary as instructed in Replacing Post-Motor Filter section. Please note that the white, pleated post-motor filter is not washable and must be replaced.
5. Grasp hose end and separate from hose base located towards bottom of the vacuum by the wheel. Check for a clog in the hose or in hose base. If you notice a clog in the base of the vacuum, remove the screw at the top left of the hose base. Lay the hose base flat and unclog with a long, narrow object such as a broom handle. Be sure to reassemble hose base with screw before operating vacuum.
6. Remove the Twist 'n Snap hose end from the vacuum by turning to the left. Straighten the hose and unclog with a long, narrow object such as a broom handle.
7. If clog persists, follow instructions for checking the rotating brush and drive belt on page 12 and inspect air passageway for obstructions.

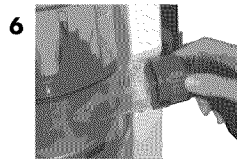
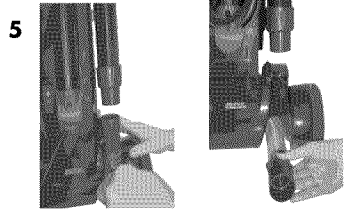

Maintenance and care

TurboBrush® Tool maintenance

Note: Model 81M9-1 comes with the Pet TurboBrush® Tool and follows same maintenance instructions.

1. Turn power OFF. Unplug vacuum cord from electrical outlet
2. Twist collar so opening is at the top and lift top cover to remove
3. Remove the brush from the drive belt to clean debris.
4. Reposition the drive belt on the brush, and place ends of brush in slots on the side.
5. Reposition top cover making sure to line up inside tab at the front with the opening of the cover. Twist collar until opening is at the bottom to lock into place.

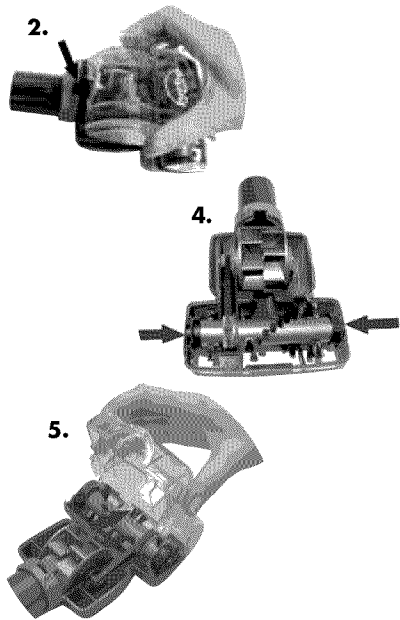

Tip:

TurboBrush® may not be turning due to loss of suction. Refer to page 14 for checking and clearing clogs.



WARNING:

To reduce the risk of electric shock, turn power OFF and disconnect polarized plug from electrical outlet before performing maintenance or troubleshooting.

Vacuum cleaner won't turn on

Possible causes

1. Power cord not plugged in
2. Blown fuse/tripped breaker in home
3. Damaged power cord
4. Thermal protector activated

Remedies

1. Check electrical plug
2. Check/replace fuse or reset breaker
3. Unplug, check for damage, have cord replaced at an authorized service center if necessary
4. Allow cleaner to cool for 30 minutes, see page 13

Vacuum cleaner and tools won't pick up dirt

Possible causes

1. Incorrect height adjustment
2. Hose not attached to suction opening
3. Twist 'n Snap hose not securely attached
4. Crack or hole in hose
5. Broken or worn drive belt
6. Rotating floor brush bristles worn
7. Rotating floor brush jammed
8. Clog in vacuum
9. Dirt container full
10. Dirt container not installed properly
11. Filters are dirty
12. TurboBrush® Tool is clogged or debris is wrapped

Remedies

1. Adjust powerfoot to correct height
2. Firmly push hose wand into hose wand base
3. Make sure Twist 'n Snap hose is snapped into locked position
4. Check hose and replace if needed
5. Replace drive belt, see page 12
6. Replace brush, see page 12
7. Remove brush and clean debris from brush ends
8. Clear dogs, see page 14
9. Empty dirt container, see page 10
10. Position correctly and lock in place, see page 10
11. Check pre-motor and post-motor filters, see page 11
12. See page 15 for Maintaining TurboBrush® Tool around the brush roll

Brush not rotating

Possible causes

1. Brush switch turned to "Off"
2. Vacuum is in upright position
3. Brush is jammed
4. Brush needs to be reset

Remedies

1. Make sure brush switch is in "On" position and handle is reclined.
2. Redline vacuum to operate brush
3. Remove obstruction or debris, see page 14, unplug cleaner to reset brush, see page 13
4. Unplug cleaner to reset brush, see page 13

Vacuum cleaner is difficult to push

Possible causes

1. Incorrect height setting

Remedies

1. Adjust powerfoot to correct height setting see, page 7



Troubleshooting

Visible dirt escaping from cleaner

Possible causes

1. Dirt container full
2. Filters missing or installed incorrectly
3. Dirt container installed incorrectly

Remedies

1. Empty dirt container, see page 10
2. Check pre-motor and post-motor filters for correct installation, see page 11
3. Pull out and re-insert dirt container correctly, see page 10

Other maintenance or service not included in the manual should be performed by an authorized service representative.

Thank you for selecting a BISSELL product.

Please do not return this product to the store.

For any questions or concerns, BISSELL is happy to be of service. Contact us directly at 1-800-237-7691.

Replacement parts – BISSELL vacuum

Item	Part No.	Part Name
1	203-1520	Drive Belt
2	203-1512	Foot Brush Roll
3	203-1509	Pre-Motor Foam Filter
4	203-1510	Post-Motor Filter
5	203-7930	Holster
6	13A2	OxyPro® Carpet Spot and Stain Remover
7	13A2-1	OxyPro® Pet Carpet Spot & Stain Remover
8	95C9	Professional Oxy Total® Carpet Spot & Stain Remover

1



2



3



4



5

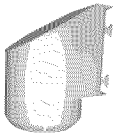

6



7



8



Additional accessories

These items are available for purchase as accessories for your BISSELL vacuum: To purchase call 1-800-237-7691 or visit www.bissell.com.

Item	Part No.	Part Name
1	203-1056	Crevice Tool
2	203-7933	Dusting Brush/Upholstery Tool
3	203-1429	TurboBrush® Tool
4	203-1068	Extension Wand
5	203-1507	Twist 'n Snap Vacuum Hose
6	203-7936	Pet TurboBrush® Tool
7	203-1291	Pet Contour Tool®

1



2



3



4



5



6

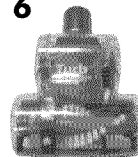

7



Warranty – BISSELL Vacuum

This warranty gives you specific legal rights, and you may also have other rights which may vary from state to state. If you need additional instruction regarding this warranty or have questions regarding what it may cover, please contact BISSELL Consumer Care by E-mail, telephone, or regular mail as described below.

Limited Three Year Warranty

Subject to the *EXCEPTIONS AND EXCLUSIONS identified below, upon receipt of the product BISSELL will repair or replace (with new or remanufactured components or products), at BISSELL's option, free of charge from the date of purchase by the original purchaser, for three years any defective or malfunctioning part.

See information below on "If your BISSELL product should require service".

This warranty applies to product used for personal, and not commercial or rental service. This warranty does not apply to fans or routine maintenance components such as filters, belts, or brushes. Damage or malfunction caused by negligence, abuse, neglect, unauthorized repair, or any other use not in accordance with the User's Guide is not covered.

If your BISSELL product should require service:

Contact BISSELL Consumer Care to locate a BISSELL Authorized Service Center in your area.

If you need information about repairs or replacement parts, or if you have questions about your warranty, contact BISSELL Consumer Care.

Website or E-mail:

www.bissell.com

Use the "Customer Care" tab.

Or Call:

BISSELL Consumer Care

1-800-237-7691

Monday - Friday 8 am - 10 pm ET

Saturday 9 am - 8 pm ET

Or Write:

BISSELL Homecare, Inc.

PO Box 1888

Grand Rapids, MI 49501

ATTN: Consumer Care

BISSELL IS NOT LIABLE FOR INCIDENTAL OR CONSEQUENTIAL DAMAGES OF ANY NATURE ASSOCIATED WITH THE USE OF THIS PRODUCT. BISSELL'S LIABILITY WILL NOT EXCEED THE PURCHASE PRICE OF THE PRODUCT.

Some states do not allow the exclusion or limitation of incidental or consequential damages, so the above limitation or exclusion may not apply to you.

***EXCEPTIONS AND EXCLUSIONS FROM THE TERMS OF THE LIMITED WARRANTY**

THIS WARRANTY IS EXCLUSIVE AND IN LIEU OF ANY OTHER WARRANTIES EITHER ORAL OR WRITTEN. ANY IMPLIED WARRANTIES WHICH MAY ARISE BY OPERATION OF LAW, INCLUDING THE IMPLIED WARRANTIES OF MERCHANTABILITY AND FITNESS FOR A PARTICULAR PURPOSE, ARE LIMITED TO THE THREE YEAR DURATION FROM THE DATE OF PURCHASE AS DESCRIBED ABOVE.

Some states do not allow limitations on how long an implied warranty last so the above limitation may not apply to you.

Don't forget to register your product!

Registering is quick, easy and offers you benefits over the lifetime of your product. You'll receive:

BISSELL Rewards Points

Automatically earn points for discounts and free shipping on future purchases.

Faster Service

Supplying your information now saves you time should you need to contact us with questions regarding your product.

Product Support Reminders and Alerts

We'll contact you with any important product maintenance reminders and alerts.

Special Promotions

Optional: Register your email to receive notice of offers, contests, cleaning tips and more!

Visit www.bissell.com/registration now!

BISSELL Consumer care

For information about repairs or replacement parts, or questions about your warranty, call:

BISSELL Consumer Care

1-800-237-7691

Monday - Friday 8 am — 10 pm ET

Saturday 9 am — 8 pm ET

Or write:

BISSELL Homecare, Inc.

PO Box 1888

Grand Rapids MI 49501

ATTN: Consumer Services

Or visit the BISSELL website -**www.bissell.com**

When contacting BISSELL, have model number of cleaner available.

Please record your Model Number: _____

Please record your Purchase Date: _____

NOTE: Please keep your original sales receipt. It provides proof of purchase date in the event of a warranty claim. See Warranty on page 19 for details.



©2012 BISSELL Homecare, Inc.
Grand Rapids, Michigan
All rights reserved. Printed in China
Part Number 110-4288
Rev 5/12
Visit our website at:
www.bissell.com

