

5KFP1333,
5KFP1444,
KJA13

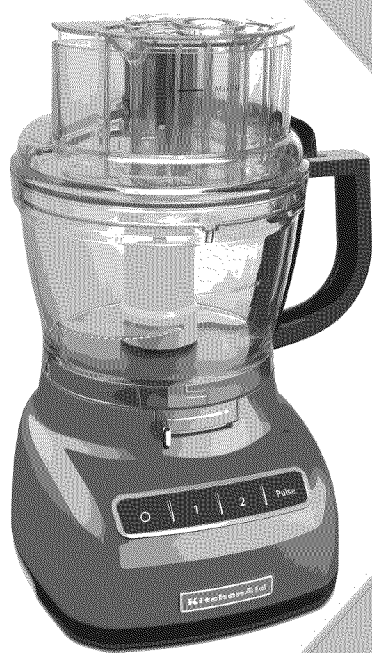

KitchenAid

Table of Contents

FOOD PROCESSOR SAFETY	
Important Safeguards.....	3
Electrical Requirements-Plastic Models.....	5
Electrical Requirements-Metal Models.....	5
PARTS AND FEATURES.....	6
ACCESSORIES	
Included Accessories.....	7
Disc Assembly Overview.....	8
Accessories Selection Guide.....	9
PREPARING THE FOOD PROCESSOR FOR FIRST USE	
Before First Use.....	10
Removing the Work Bowl Cover from the Work Bowl.....	10
Storing Parts.....	10
SETTING UP YOUR FOOD PROCESSOR	
Attaching the Work Bowl.....	11
Attaching the Work Bowl Cover.....	11
Installing the Adjustable Slicing Disc.....	12
Adjusting the Slicing Thickness.....	12
Installing Other Slicing or Shredding Discs.....	13
Installing the Multipurpose Blade or Dough Blade.....	14
Installing the Mini-Bowl and Mini-Blade.....	14
Using the 3-in-1 Feed Tube.....	15
USING YOUR FOOD PROCESSOR	
Before Use.....	16
Maximum Liquid Level.....	16
Using the Speed 1/Speed 2 Control.....	16
Using the Pulse Control.....	16
Removing Processed Foods.....	17
CARE AND CLEANING.....	18
TIPS FOR GREAT RESULTS	
Using the Multipurpose Blade.....	18
Using a Slicing or Shredding Disc.....	19
Using the Dough Blade.....	20
Helpful Hints.....	20
TROUBLESHOOTING.....	22

For more information, visit our website at: KitchenAid.com.au

Your safety and the safety of others are very important.

We have provided many important safety messages in this manual and on your appliance. Always read and obey all safety messages.



This is the safety alert symbol.

This symbol alerts you to potential hazards that can kill or hurt you and others.

All safety messages will follow the safety alert symbol and either the word "DANGER" or "WARNING." These words mean:



You can be killed or seriously injured if you don't immediately follow instructions.



You can be killed or seriously injured if you don't follow instructions.

All safety messages will tell you what the potential hazard is, tell you how to reduce the chance of injury, and tell you what can happen if the instructions are not followed.

IMPORTANT SAFEGUARDS

When using electrical appliances, basic safety precautions should always be followed, including the following:

1. Read all instructions. Misuse of appliance may result in personal injury.
2. To protect against risk of electrical shock, do not put Food Processor in water or other liquid.
3. This appliance is not intended for use by persons with reduced physical sensory or mental capabilities, or lack of experience and knowledge, unless they have been given supervision or instructions concerning use of the appliance in a safe way and understand the hazards involved.
4. Children should be supervised to insure they do not play with the appliance. The appliance is not to be used by children. The appliance and cord should be out of reach of children. Children shall not clean or perform user maintenance on the appliance without supervision.
5. Unplug from the outlet when not in use, before putting on or taking off parts, and before cleaning.
6. Avoid contacting moving parts.

FOOD PROCESSOR SAFETY

7. Do not operate any appliance with a damaged cord or plug, or after the appliance malfunctions, or is dropped or damaged in any manner. Return appliance to the nearest Authorized Service Facility for examination, repair, or electrical or mechanical adjustment, in order to avoid a hazard.
8. The use of attachments not recommended or sold by KitchenAid may cause fire, electric shock, or injury.
9. Do not use outdoors.
10. Do not let cord hang over edge of table or counter.
11. Keep hands and utensils away from moving blades or discs while processing food to reduce the risk of severe injury to persons or damage to the Food Processor. A scraper may be used but must be used only when the Food Processor is not running.
12. Blades are sharp. Care should be taken when handling the sharp cutting blades, emptying the bowl and during cleaning.
13. To reduce the risk of injury, never place cutting blade or discs on base without first putting bowl properly in place.
14. Be certain cover is securely locked in place before operating appliance.
15. Never feed food by hand. Always use the food pusher.
16. Do not attempt to defeat the cover interlock mechanism.
17. To disconnect, turn any control to "OFF," then remove plug from wall outlet.
18. This appliance is intended to be used in household and similar applications such as:
 - staff kitchen areas in shops, offices, and other working environments
 - farm houses
 - by clients in hotels, motels, and other residential type environments
 - bed and breakfast type environments.
19. Be careful if hot liquid is poured into the Food Processor as it can be ejected out of the appliance due to a sudden steaming.

SAVE THESE INSTRUCTIONS

Electrical Requirements- Plastic Models

⚠ WARNING



Fire Hazard

Do not use an extension cord.

Doing so can result in death or fire.

Volts: 220-240 Volts VAC
Hertz: 50/60 Hz

NOTE: This Food Processor is equipped with a polarized plug (one blade is wider than the other). To reduce the risk of electrical shock, this plug will fit in a polarized outlet only one way. If the plug does not fit fully in the outlet, reverse the plug. If it still does not fit, contact a qualified electrician. Do not modify the plug in any way.

Do not use an extension cord. If the power supply cord is too short, have a qualified electrician or serviceman install an outlet near the appliance.

Electrical Requirements- Metal Models

⚠ WARNING



Electrical Shock Hazard

Plug into a grounded outlet.

Do not remove ground prong.

Do not use an adapter.

Do not use an extension cord.

Failure to follow these instructions can result in death, fire, or electrical shock.

Volts: 220-240 Volts VAC
Hertz: 50/60 Hz

NOTE: This Food Processor has a grounded plug. To reduce the risk of electrical shock, this plug will fit in an outlet only one way. If the plug does not fit in the outlet, contact a qualified electrician. Do not modify the plug in any way.

Do not use an extension cord. If the power supply cord is too short, have a qualified electrician or serviceman install an outlet near the appliance.

A short power supply cord (or detachable power supply cord) should be used to reduce the risk resulting from becoming entangled in or tripping over a longer cord.

Longer detachable power supply cords or extension cords are available and may be used.

If a longer detachable power supply cord or extension cord is used:

- The marked electrical rating of the cord set or extension cord should be at least as great as the electrical rating of the appliance.
- The cord should be arranged so that it will not drape over the countertop or tabletop where it can be pulled on by children or tripped over unintentionally.

If the appliance is of the grounded type, the extension cord should be a grounding-type 3-wire cord.

PARTS AND FEATURES

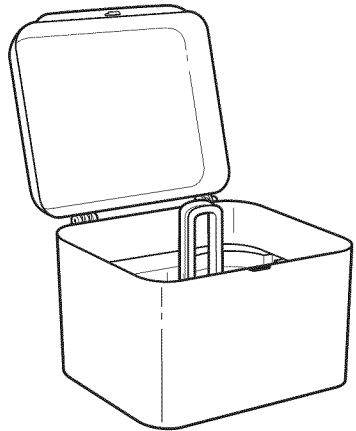
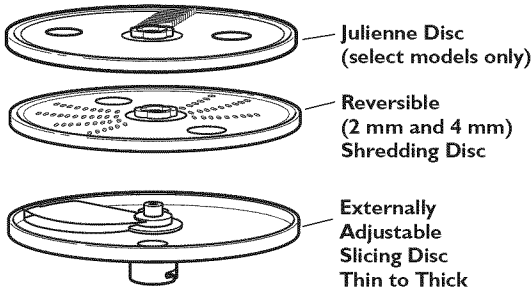

Chef's Accessory Case

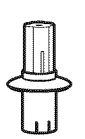

Disc Adapter



Slicing Adapter

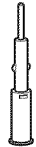

Drive Adapter

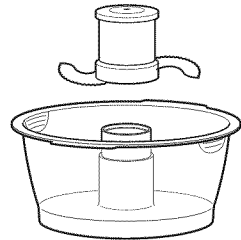

**945 ml (4-Cup)
Mini-Bowl and
Mini-Blade**

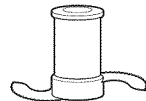

**Stainless Steel
Multipurpose
Blade**

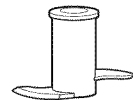

Dough Blade

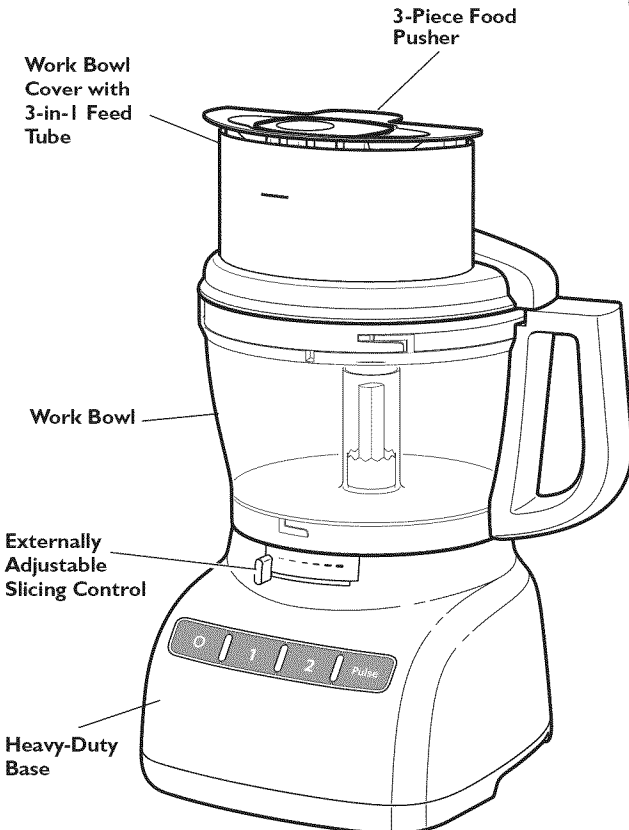

PARTS AND FEATURES

Important parts and accessories included with your new Food Processor are highlighted below. Refer to the following pages for additional details on accessories included with your Food Processor as well as optional accessories you can order separately (some optional accessories included with select models).

Externally Adjustable Slicing Control

KitchenAid brand's exclusive externally adjustable slicing disc allows you to adjust slicing thickness from thin to thick, without having to remove the blade assembly. With the slicing disc installed, simply slide the Slicing Thickness Control to the desired setting - no need to remove the cover or even turn off the Food Processor.

Speed 1/ Speed 2/ Pulse Control

Two speeds and Pulse provide precise control to give great results with most any food.

Work Bowl Cover with 3-in-1 Feed Tube

One of the industry's largest, the 3-in-1 feed tube accommodates large items – like tomatoes, cucumbers, and potatoes – with a minimum of sectioning or slicing.

3-Piece Food Pusher

Three pushers are nested inside of each other. Remove the medium pusher from the large pusher to reveal a medium-size feed tube for continuous processing.

For continuous processing of smaller items (like herbs, nuts, single carrots, and celery), remove the narrow pusher and use the narrow feed tube.

A small hole in the bottom of the narrow pusher makes it easy to drizzle oil into ingredients – just fill with the desired amount of oil or other liquid ingredient.

Heavy-Duty Base

The heavy, slip-resistant base helps provide improved stability and reduced vibration during tough food processing jobs.

ACCESSORIES

Included Accessories

945 ml (4-cup) Mini-Bowl and Mini-Blade

Mini-bowl and stainless steel mini-blade are perfect for small chopping and mixing jobs.

Work Bowl

The durable, large work bowl provides capacity for large jobs.

Externally Adjustable Slicing Disc

Disc is adjustable from approximately 1 mm ($1/16$ inch) to 6 mm ($1/4$ inch) for slicing most foods.

Reversible Shredding Disc

Shredding disc is reversible to allow coarse or finely shredded cheese or vegetables.

Drive Adapter

The drive adapter is used with the appropriate adapter to connect the slicing/shredding discs and mini-blade to the power shaft on the base.

Disc Adapter

Adapter fits over the drive adapter and into the bottom of the adjustable slicing disc.

Julienne Disc (Select Models Only)

Julienne disc is great for making shoestring potatoes or vegetables.

Slicing Adapter

Adapter fits over the drive adapter and into the bottom of the shredding or Julienne disc.

Stainless Steel Multipurpose Blade

Versatile blade chops, minces, blends, mixes, and emulsifies in a matter of seconds.

Dough Blade

The dough blade is specially designed for mixing and kneading yeast dough.

Chef's Accessory Case

Stylish and durable case organizes and protects blades, discs, and accessories.

Spatula/Cleaning Tool (not shown)

Special shape facilitates food removal from bowls, discs, and blades.

ACCESSORIES

Disc Assembly Overview

There are two different disc adapters included with the food processor. One is used exclusively with the adjustable slicing disc. The other is used with all other discs.

Adjustable Slicing Disc

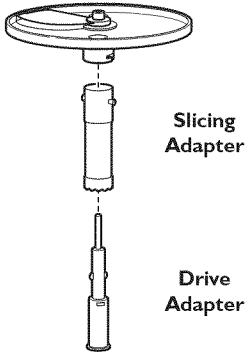

Reversible Shredding Disc

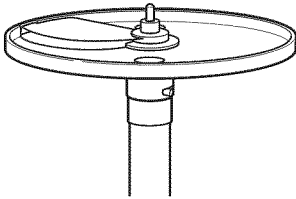
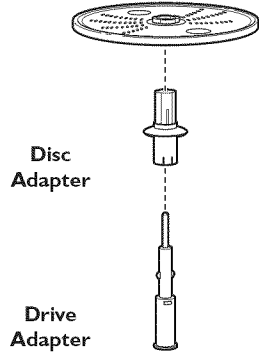



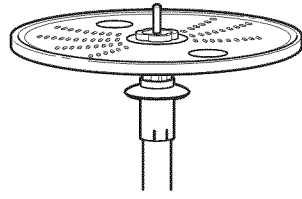







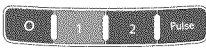



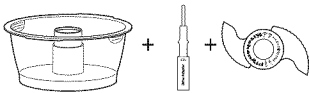

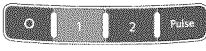
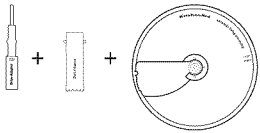

Properly assembled

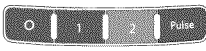
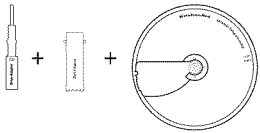
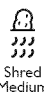
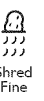

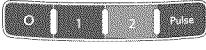
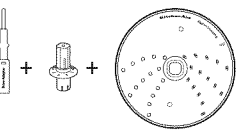
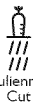
ACCESSORIES

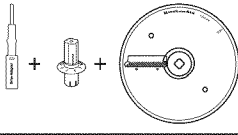
Accessories selection guide

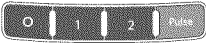
Not all accessories shown are included with all models.

Action	Setting	Food	Accessory
 Chop		Cheese Chocolate Fruit Fresh herbs Nuts Tofu Vegetables	Multipurpose Stainless Steel Blade 
  Mince Puree		Pasta Sauce Pesto Salsa Sauces	OR Mini-bowl and Mini Multipurpose Stainless Steel Blade 
 Mix		Fruit (soft) Potatoes Tomatoes Vegetables (soft)	Adjustable Slicing Disc 
  Slice Thin Slice Thick	 	Cheese Chocolate Fruit (hard) Vegetables (hard)	
  Shred Medium Shred Fine	 	Potatoes Vegetables (soft) Cabbage Cheese Chocolate Fruit (hard) Vegetables (hard)	Reversible Shredding Disc 
 Julienne Cut	 	Potatoes Vegetables (soft) Vegetables (hard)	Julienne Disc 
 Knead		Batter Sweet dough Yeast dough	Plastic Dough Blade 

ENGLISH

PREPARING THE FOOD PROCESSOR FOR FIRST USE

⚠ WARNING

Cut Hazard

Handle blades carefully.

Failure to do so can result in cuts.

Before First Use

Before using your Food Processor for the first time, wash the work bowl, work bowl cover, mini-bowl, feed tube pushers, discs, and blades either by hand or in the dishwasher (see "Cleaning the Food Processor").

Removing the Work Bowl Cover from the Work Bowl

Your Food Processor is shipped with the work bowl cover installed on the work bowl, with the mini-bowl inside the work bowl.

To remove the work bowl cover from the work bowl for initial cleaning:

1. Grasp the feed tube on the work bowl cover and turn it clockwise to remove it from the work bowl.

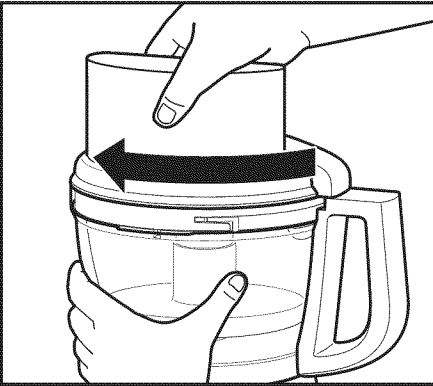

2. Lift out the mini-bowl.

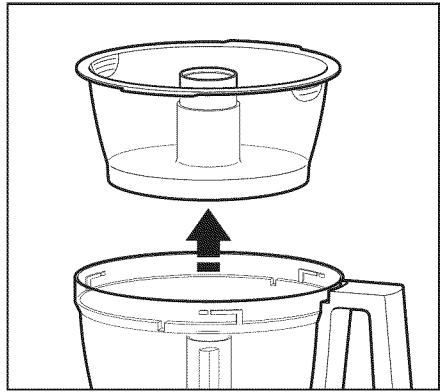

Storing Parts

Once washed, disassembled discs, shafts, and blades should be stored in the provided storage case, in a location out of the reach of children.

The mini-bowl can nest inside the work bowl for convenient storage.

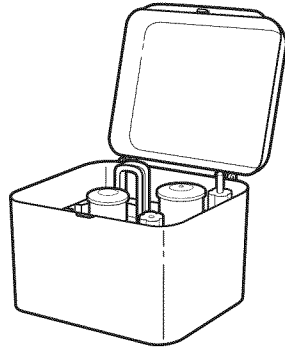

SETTING UP YOUR FOOD PROCESSOR

Attaching the Work Bowl

1. Place the Food Processor on a dry, level countertop with the controls facing forward. Do not plug in the Food Processor until it is completely assembled.
2. Place the work bowl on the base, aligning the raised portion with the indentation on the base. The center hole should fit over the power shaft.

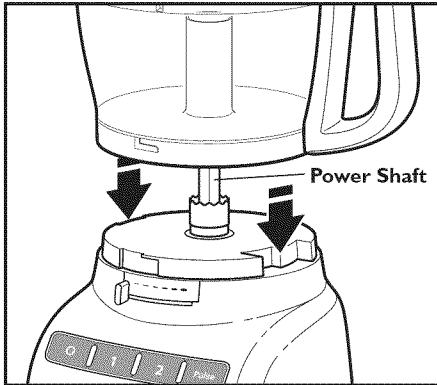

3. Grasp the work bowl handle and turn the bowl counterclockwise to lock it on the base.

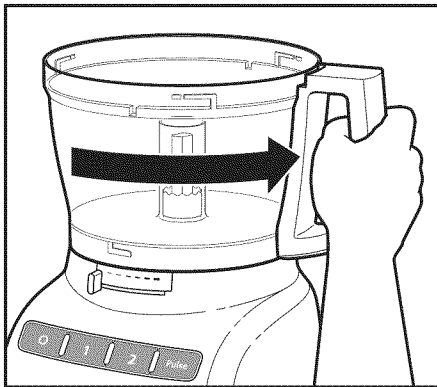

Select the accessory you would like to use and install it according to the instructions on the following pages.

Attaching the Work Bowl Cover

NOTE: Be sure to install the desired accessory before attaching the work bowl cover.

1. Place the work bowl cover on the work bowl with the feed tube just to the left of the work bowl handle. Grasp the feed tube and turn the cover to the right until it locks into place.

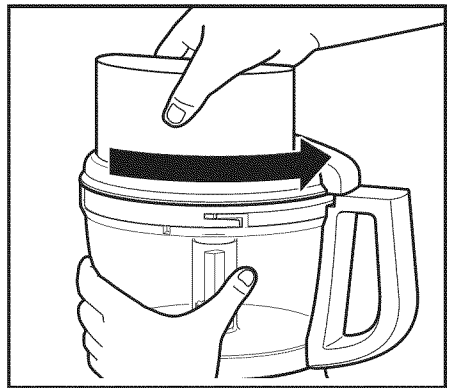

2. Fit the food pusher into the 3-in-1 feed tube. See "Using the 3-in-1 Feed Tube" for details on working with different sized foods.

NOTE: Your Food Processor will not operate unless the work bowl and work bowl cover are properly locked on the base, and the large pusher is inserted to the maximum fill line on the feed tube (approximately halfway down).

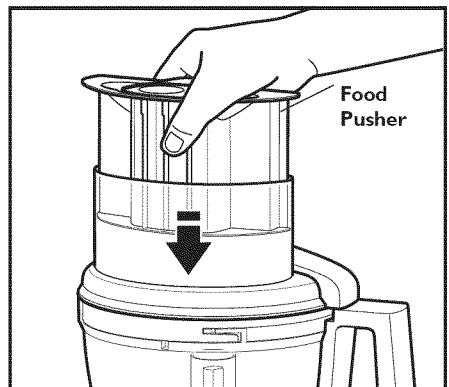

SETTING UP YOUR FOOD PROCESSOR

Installing the Adjustable Slicing Disc

IMPORTANT: The adjustable slicing disc can only be installed in one direction.

1. With the work bowl installed, place the drive adapter on the power shaft of the base.

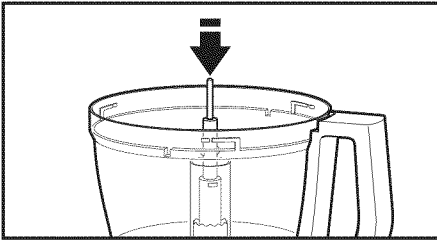

2. Holding the adjustable slicing disc by the 2 finger grips, align the pins onto the adjustable slicing disc adapter into the L-slots on the disc. Slide the disc down onto the adapter and turn to engage the pins in the L-slot.

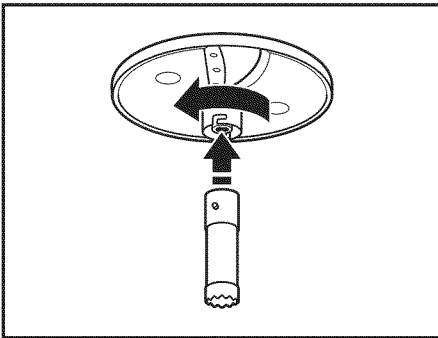

3. Lower the slicing blade and slicing adapter onto the drive adapter.

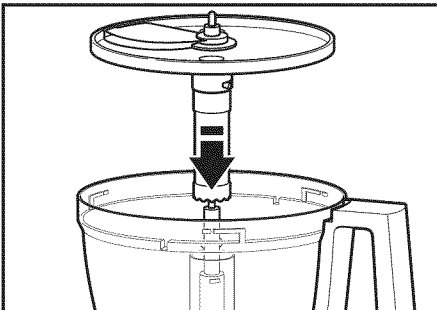

TIP: You may need to turn the disc/drive adapter until it drops down into place.

4. Install the work bowl cover, being sure it locks into place.

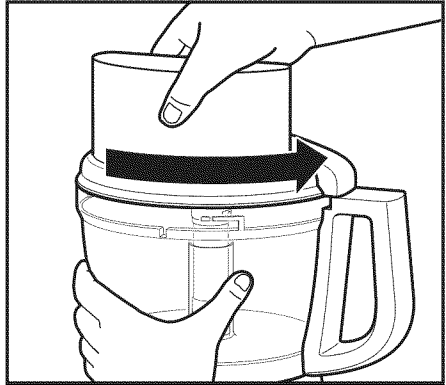

Adjusting the Slicing Thickness

Set the desired slicing thickness by moving the lever to the left for thinner slices or to the right for thicker slices.

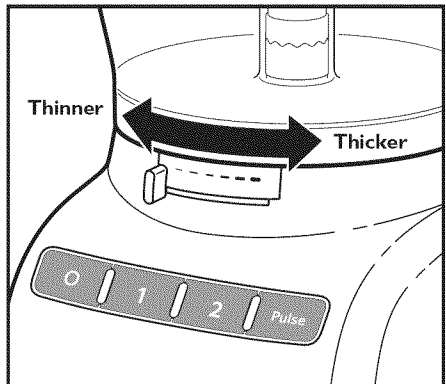

NOTE: The lever only works with the adjustable slicing disc. Changing thickness settings with other discs or blades installed will have no effect on operation.

SETTING UP YOUR FOOD PROCESSOR

Installing Other Slicing or Shredding Discs

IMPORTANT: The optional julienne and plane/shave discs can only be installed in one direction. When using the reversible shredding disc, have the desired side (medium/fine) facing UP.

1. Holding the desired disc by the 2 finger grips, insert the slicing/shredding adapter into the hole in the bottom of the disc.

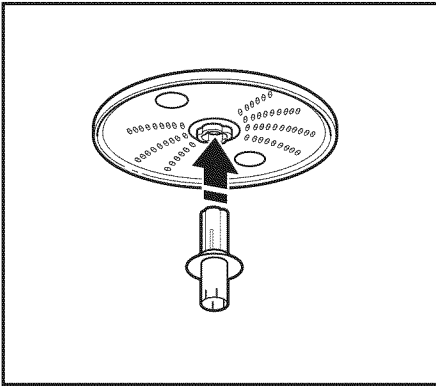

2. Slide the drive adapter into the slicing adapter as far as it will go, until it clicks into place.

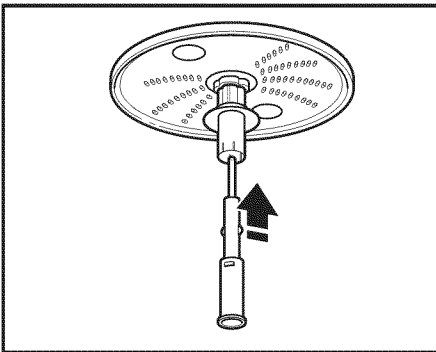

3. With the work bowl installed, slide the drive adapter onto the power shaft.

TIP: You may need to turn the disc/drive adapter until it drops down into place.

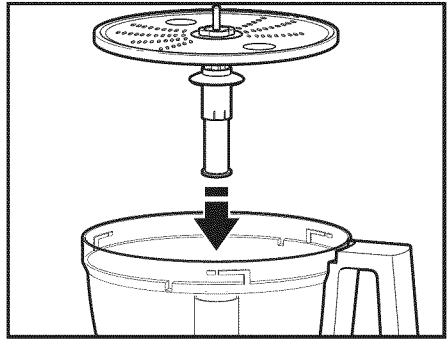

4. Install the work bowl cover, being sure it locks into place.

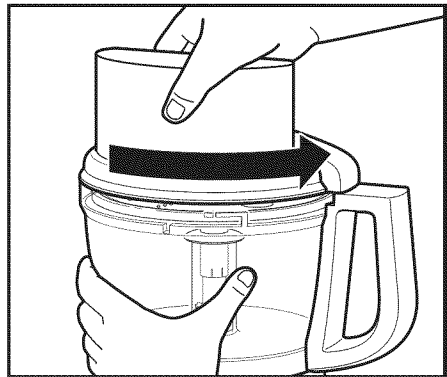

SETTING UP YOUR FOOD PROCESSOR

Installing the Multipurpose Blade or Dough Blade

IMPORTANT: The multipurpose blade and dough blade can only be used with the work bowl.

1. Place the blade on the power shaft.
2. Rotate the blade so it falls into place on the power shaft.

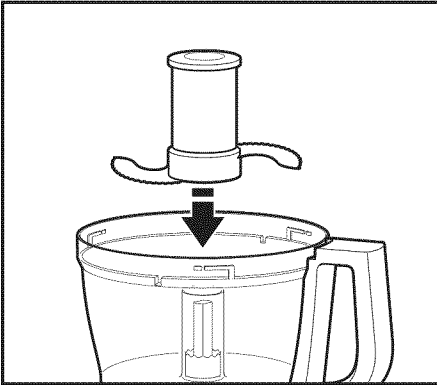

3. Push to lock: Press down firmly on the multipurpose blade until it is down as far as it will go. The multipurpose blade features an internal seal that fits tightly over the center of the work bowl.



4. Install the work bowl cover, being sure it locks into place.

Installing the Mini-Bowl and Mini-Blade

1. Place the mini-bowl inside the work bowl over the power shaft. Rotate the mini-bowl until the tabs on the top edge of the bowl drop into the indents on the top of the work bowl.

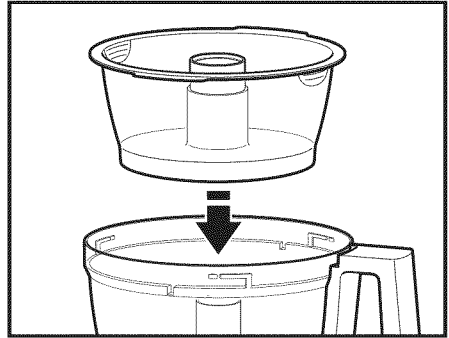

2. Insert the drive adapter into the mini-blade, and place on the power shaft. It may be necessary to rotate the blade until it falls into place. Press down firmly to lock it into place.

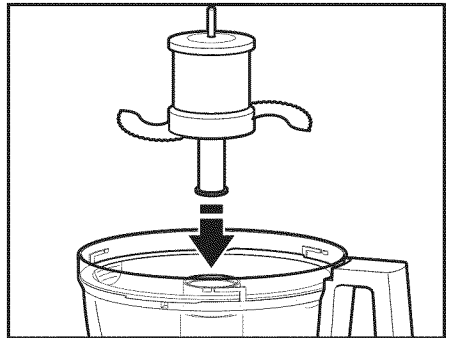

3. Install the work bowl cover, being sure it locks into place.
4. To remove the mini-bowl after processing, remove the mini-blade by pulling straight up on the cap. Then lift the bowl straight up and out, using the two finger grips located along the top edge of the bowl.

Using the 3-in-1 Feed Tube

The 3-in-1 feed tube features a 3-piece food pusher. Use the entire food pusher to process large items, or use the inner portions to create medium-sized or small feed tubes to process smaller items.

To slice or shred small items, insert the 3-piece food pusher into the feed tube, then lift out the small pusher to remove. Use the small feed tube and pusher to process small or slender items, like single carrots or celery stalks. When not using the small feed tube, be sure to lock the small pusher into place.

To slowly drizzle oil or other liquid ingredients into the work bowl, just fill the small pusher with the desired amount of liquid. A small hole in the bottom of the pusher will drizzle the liquid ingredient at a constant rate.

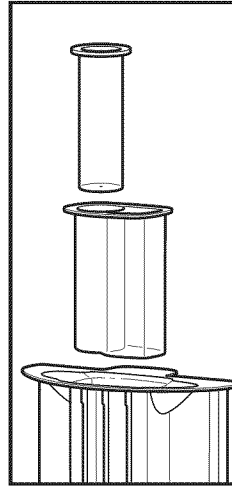

USING YOUR FOOD PROCESSOR

WARNING



Rotating Blade Hazard

Always use food pusher.

Keep fingers out of openings.

Keep away from children.

Failure to do so can result in amputation or cuts.

Before Use

Before operating the Food Processor, be sure the work bowl, blades, and work bowl cover are properly assembled on the Food Processor base (see "Setting Up Your Food Processor").

Maximum Liquid Level

This line on the work bowl indicates the maximum level of liquid that can be processed by the Food Processor.

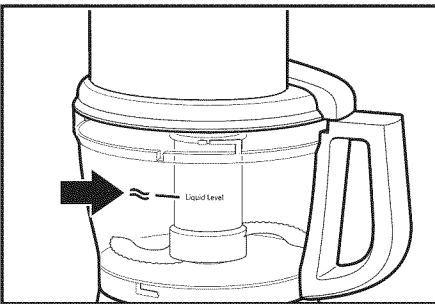

Using the Speed 1/Speed 2 Control

1. To turn on the Food Processor, press the Speed 1 or Speed 2 button. The Food Processor will run continuously and the indicator light will glow.
2. To stop the Food Processor, press the "O" (OFF) button. The indicator light will go out and the blade or disc will stop within a few seconds.
3. Wait until the blade or disc comes to a complete stop before removing the work bowl cover. Be sure to turn off the Food Processor before removing the work bowl cover, or before unplugging the Food Processor.

NOTE: If the Food Processor fails to operate, make sure the work bowl and cover are properly locked on the base (see "Setting Up Your Food Processor").

Using the Pulse Control

The pulse control allows precise control of the duration and frequency of processing. It's great for jobs which require a light touch. Just press and hold the PULSE Button to start processing at high speed, and release it to stop.

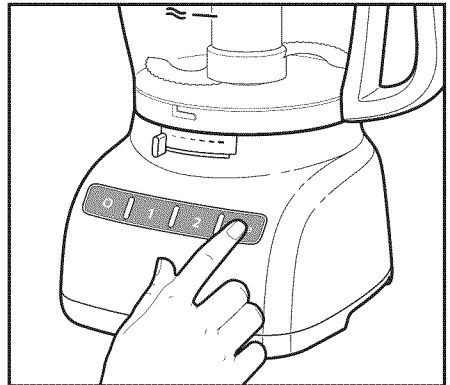

USING YOUR FOOD PROCESSOR

Removing Processed Foods

⚠️ WARNING

Cut Hazard
Handle blades carefully.
Failure to do so can result in cuts.

1. Press the "O" (OFF) Button.
2. Unplug the Food Processor before disassembling.

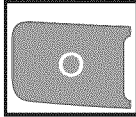

3. Turn the work bowl cover to the left and remove.

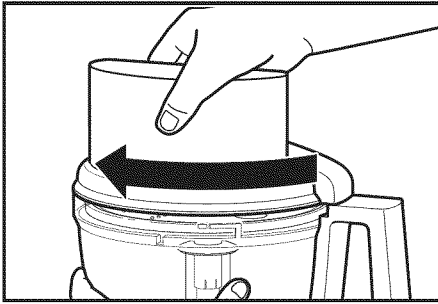

4. If using a disc, remove it before removing the bowl. Holding the disc by the 2 finger grips, lift it straight up. Remove the adapter.

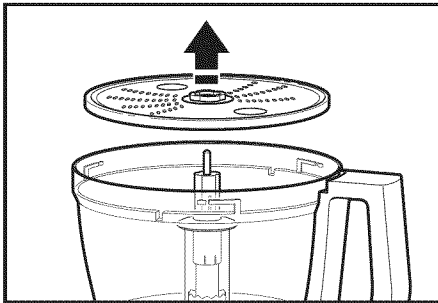

5. If using the mini-bowl, grasp and remove the bowl using the finger grips located along the top edge of the bowl.

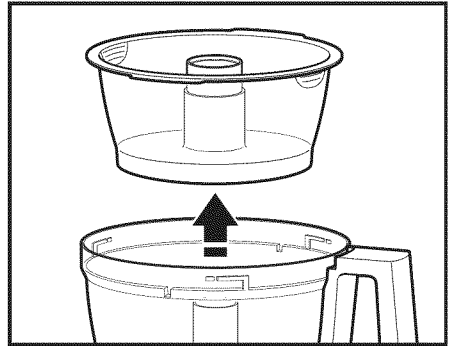

6. Turn the work bowl to the left to unlock it from the base. Lift to remove.

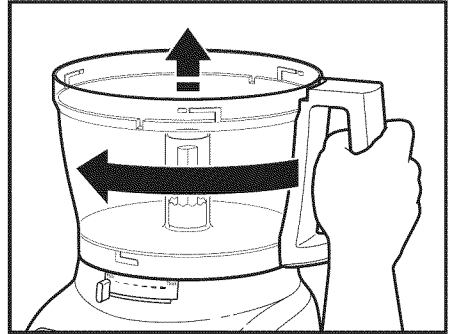

7. The multipurpose blade can be removed from the work bowl before the contents are emptied. You may also leave the blade locked in place. Then remove food from the bowl and blade with a spatula.

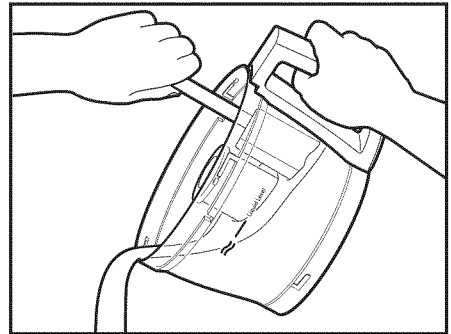

CARE AND CLEANING

⚠️ WARNING

Cut Hazard

Handle blades carefully.

Failure to do so can result in cuts.

1. Press the "O"(OFF) Button.
2. Unplug the Food Processor before Cleaning.
3. Wipe the base and cord with a warm, sudsy cloth, and wipe clean with a damp cloth. Dry with a soft cloth. Do not use abrasive cleansers or scouring pads.
4. Please note these BPA-free bowls require special handling. If you choose to use a dishwasher instead of hand washing, please follow these guidelines.
 - All parts are top rack dishwasher safe.
 - Avoid laying the bowl on its side.
 - Use gentle dishwashing cycles such as Normal. Avoid high temperature cycles such as Sanitize, Steam, and Pot Scrubbing.
5. If washing the Food Processor parts by hand, avoid the use of abrasive cleansers or scouring pads. They may scratch or cloud the work bowl and cover. Thoroughly dry all parts after washing.

6. To prevent damage to the locking system, always store the work bowl and work bowl cover in the unlocked position when not in use.

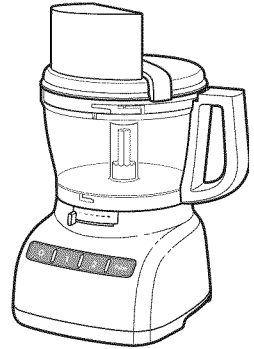

7. Wrap the power cord around the work bowl. Secure the plug by clipping it to the cord.
8. Disassembled discs, shafts, and blades should be stored in the provided storage case, and in a location out of the reach of children.

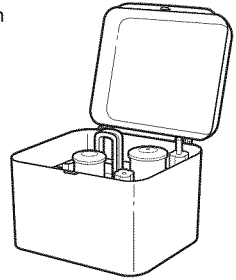

TIPS FOR GREAT RESULTS

⚠️ WARNING

Cut Hazard

Handle blades carefully.

Failure to do so can result in cuts.

Using the Multipurpose Blade



To chop fresh fruits or vegetables:

Peel, core, and/or remove seeds. Cut food in 2.5-3.75 cm (1 to 1½-inch) pieces. Process food to desired size, using Speed 1. Scrape sides of bowl, if necessary.

To puree cooked fruits and vegetables (except potatoes):

Add 60 ml (¼ cup) liquid from recipe per 235 ml (1 cup) of food. Process food, using short pulses, until finely chopped. Then process continuously until reaching desired texture. Scrape sides of bowl, if necessary.

To prepare mashed potatoes:

Shred hot cooked potatoes using the shredding disc. Exchange shredding disc for multipurpose blade. Add softened butter, milk, and seasonings. Pulse 3 to 4 times, 2 to 3 seconds each time, until smooth and milk is absorbed. Do not over process.

To chop dried (or sticky) fruits:

The food should be cold. Add 60 ml (¼ cup) flour from recipe per 120 ml (½ cup) dried fruit. Process fruit, using short pulses, until reaching desired texture.

TIPS FOR GREAT RESULTS

To finely chop citrus peel:

With sharp knife, peel colored portion (without white membrane) from citrus. Cut peel in small strips. Process until finely chopped.

To mince garlic or to chop fresh herbs or small quantities of vegetables:

With processor running, add food through the feed tube. Process until chopped. For best results, make sure work bowl and herbs are very dry before chopping.

To chop nuts or make nut butters:

Process up to 710 ml (3 cups) of nuts to desired texture, using short pulses, 1 to 2 seconds each time. For a coarser texture, process smaller batches, pulsing 1 or 2 times, 1 to 2 seconds each time. Pulse more often for finer texture. For nut butters, process continuously until smooth. Store in refrigerator.

NOTE: Processing nuts and other hard foods may scratch the surface finish on the inside of the bowl.

To chop cooked or raw meat, poultry or seafood:

The food should be very cold. Cut in 2.5 cm (1-inch) pieces. Process up to 455 g (1 pound) at a time to desired size, using short pulses, 1 to 2 seconds each time. Scrape sides of bowl, if necessary.

To make bread, cookie, or cracker crumbs:

Break food into 3.75-5 cm (1½ to 2-inch) pieces. Process until fine. For larger pieces, pulse 2 to 3 times, 1 to 2 seconds each time. Then process until fine.

To melt chocolate in a recipe:

Combine chocolate and sugar from recipe in work bowl. Process until finely chopped. Heat liquid from recipe. With processor running, pour hot liquid through the feed tube. Process until smooth.

To grate hard cheeses, such as Parmesan and Romano:

Never attempt to process cheese that cannot be pierced with the tip of a sharp knife. You can use the multi-purpose blade to grate hard cheeses. Cut cheese in 2.5 cm (1-inch) pieces. Place in work bowl. Process, using short pulses, until coarsely chopped. Process continuously until finely grated. Pieces of cheese can also be added through the feed tube while the processor is running.

! WARNING



Rotating Blade Hazard

Always use food pusher.

Keep fingers out of openings.

Keep away from children.

Failure to do so can result in amputation or cuts.

Using a Slicing or Shredding Disc



To slice or shred fruits or vegetables that are long and relatively small in

diameter, such as celery, carrots, and bananas:

Cut food to fit wide mouth feed tube vertically or horizontally, and pack feed tube securely to keep food positioned properly. Do not exceed the Max Fill line. Process using even pressure with wide food pusher.

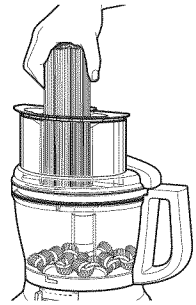

Or use the small feed tube in the two-piece food pusher. Position food vertically in the tube and use the small food pusher to process food.

To slice or shred fruits and vegetables that are round, such as onions, apples, and green peppers:

Peel, core, and remove seeds. Cut in halves or quarters to fit feed tube. Position in feed tube. Process using even pressure with food pusher.

TIPS FOR GREAT RESULTS

To slice or shred fruits and vegetables that are small, such as strawberries, mushrooms, and radishes:

Position food vertically or horizontally in layers within the feed tube. Fill feed tube in order to keep food positioned properly. Process, using even pressure. Or use the small feed tube in the two-piece food pusher. Position food vertically in the tube and use the small food pusher to process food.

To slice uncooked meat or poultry, such as stir-fry meats:

Cut or roll food to fit feed tube. Wrap and freeze food until hard to the touch, 30 minutes to 2 hours, depending on thickness of food. Check to be sure you can still pierce food with the tip of a sharp knife. If not, allow to thaw slightly. Process using even pressure with food pusher.

To slice cooked meat or poultry, including salami, pepperoni, etc.:

Food should be very cold. Cut in pieces to fit feed tube. Process food using firm, even pressure with food pusher.

 **To shred spinach and other leaves:** Stack leaves. Roll up and stand up in feed tube.

Process using even pressure with food pusher.

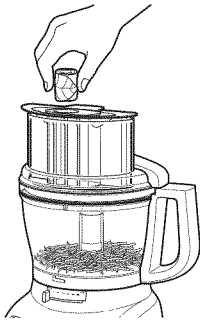

To shred firm and soft cheeses:

Firm cheese should be very cold. For best results with soft cheeses, such as mozzarella, freeze 10 to 15 minutes before processing. Cut to fit feed tube. Process using even pressure with food pusher.

 **To cut julienne, or match stick, strips of vegetables and fruits using the julienne disc (on select models):**

Cut food to fit feed tube horizontally for longer pieces or vertically for smaller pieces. Position food in feed tube to guide the food. Process using even pressure with food pusher.

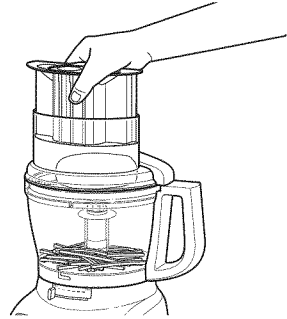

Using the Dough Blade

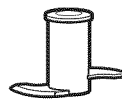

The dough blade is specially designed for mixing and kneading yeast dough quickly and thoroughly. For the best results, do not knead recipes which use more than 475 - 710 ml (2-3 cups) of flour.

Helpful Hints

- To avoid damage to the blade or motor, do not process food that is so hard or firmly frozen that it cannot be pierced with the tip of a sharp knife. If a piece of hard food, such as a carrot, becomes wedged or stuck on the blade, stop the processor and remove the blade. Gently remove food from the blade.
- Do not overfill work bowl or mini-bowl. For thin mixtures, fill work bowl up to 1/2 to 2/3 full. For thicker mixtures, fill work bowl up to 3/4 full. For liquids, fill up to the maximum level as described on page 17. When chopping, the work bowl should be no more than 1/3 to 1/2 full. Use the mini-bowl for up to 235 ml (1 cup) of liquid or 155 g (1/2 cup) solids.
- Position slicing discs so the cutting surface is just to the right of the feed tube. This allows the blade a full rotation before contacting the food.

TIPS FOR GREAT RESULTS

- To capitalize on the speed of the processor, drop ingredients to be chopped through the feed tube while the processor is running.
- Different foods require varying degrees of pressure for best shredding and slicing results. In general, use light pressure for soft, delicate foods (strawberries, tomatoes, etc.), moderate pressure for medium foods (zucchini, potatoes, etc.), and firmer pressure for harder foods (carrots, apples, hard cheeses, partially frozen meats, etc.).
- Soft and medium-hard cheese may spread out or roll up on the shredding disc. To avoid this, shred only well-chilled cheese.
- Sometimes slender foods, such as carrots or celery, fall over in the feed tube, resulting in an uneven slice. To minimize this, cut food in several pieces and pack the feed tube with the food. For processing small or slender items, the small feed tube in the two piece food pusher will prove especially convenient.

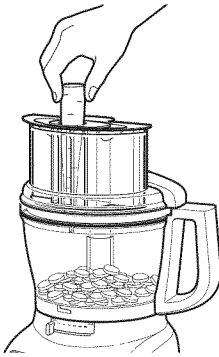

- When preparing a cake or cookie batter or quick bread, use the multipurpose blade to cream fat and sugar first. Add dry ingredients last. Place nuts and fruit on top of flour mixture to prevent overchopping. Process nuts and fruits, using short pulses, until blended with other ingredients. Do not overprocess.
- When shredded or sliced food piles up on one side of the bowl, stop the processor and redistribute the food using a spatula.
- When food quantity reaches the bottom of a slicing or shredding disc, remove the food.

- A few larger pieces of food may remain on top of the disc after slicing or shredding. If desired, cut these by hand and add to mixture.
- Use the spatula to remove ingredients from the work bowl.



- Organize processing tasks to minimize processing bowl cleanup. Process dry or firm ingredients before liquid ingredients.
- To clean ingredients from the multipurpose blade easily, just empty the work bowl, replace the lid, and pulse 1 to 2 seconds to spin the blade clean.
- After removing the work bowl cover, place it upside down on the counter. This will help keep the counter clean.
- Your Food Processor is not designed to perform the following functions:
 - Grind coffee beans, grains, or hard spices
 - Grind bones or other inedible parts of food
 - Liquefy raw fruits or vegetables
 - Slice hard-cooked eggs or unchilled meats.
- If any plastic parts should discolor due to the types of food processed, clean them with lemon juice.

TROUBLESHOOTING

If your Food Processor should malfunction or fail to operate, check the following:

Food Processor doesn't run:

- Make sure that the bowl and lid are properly aligned and locked in place and the large food pusher is inserted in the feed tube.
- When using the large feed tube opening, make sure that food is not above the Max Fill line on the feed tube.

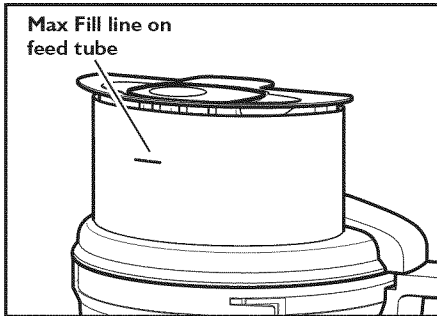

- Press only one button at a time. The Food Processor will not operate if more than one button is pressed at the same time.
- Is the Food Processor plugged in?
- Is the fuse in the circuit to the Food Processor in working order? If you have a circuit breaker box, be sure the circuit is closed.
- Unplug the Food Processor, then plug it back into the outlet.
- If the Food Processor is not at room temperature, wait until it reaches room temperature and retry.

Food Processor not shredding or slicing properly:

- Make sure the raised-blade side of the disc is positioned face up on the common adapter.
- If using the adjustable slicing blade, make sure it is set to the correct thickness.
- Make sure ingredients are suitable for slicing or shredding. See "Tips for Great Results."

If the work bowl cover won't close when using the disc:

- Make sure the disc is installed correctly, with the raised nub on top, and is positioned properly on the drive adapter.

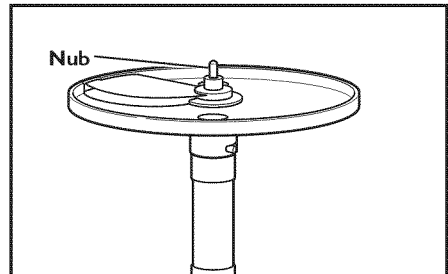

KitchenAid

Whirlpool S.A.
Unidade de Eletrodomesticos
Atendimento ao Consumidor
Rua Olympia Semeraro n° 675
Jardim Santa Emilia CEP 04183-901
Sao Paulo - SP - Caixa postal 5171
Capitals e regioes metropolitanas: 4004 1759
Demais localidades: 0800 722 1759

© 2015 KitchenAid. All rights reserved.
Specifications subject to change without notice.
© 2015. Todos os direitos reservados.
Especificacoes sujeitas a alteracao sem previo aviso.
© 2015. 保留所有的权利。
© 2015. 모든 권한 보유.

W10508883E

03/15