

Operator's Manual

CRAFTSMAN®

NEXTEC

12-Volt Lithium-Ion Cordless Multi-Tool

Model No. 320.61199

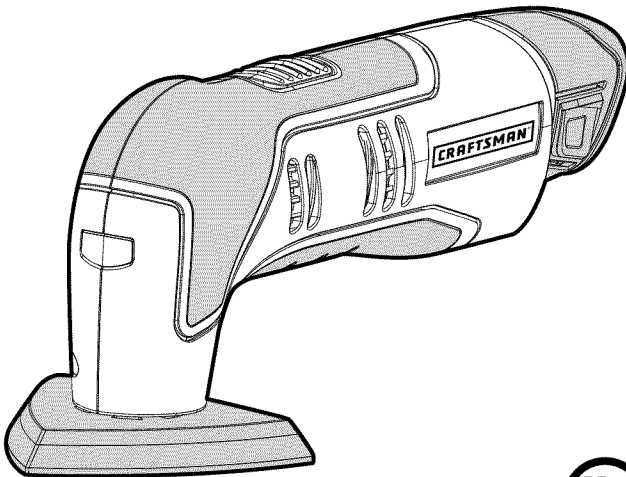

Powered by an
ENERGY STAR®
qualified battery
charger for a
better environment



⚠ WARNING: To reduce the risk of injury,
the user must read and understand the
Operator's manual before using this product.

Charge battery Before first use

- **WARRANTY**
- **SAFETY**
- **ASSEMBLY**
- **OPERATION**
- **MAINTENANCE**
- **ESPAÑOL**

**Sears Brands Management Corporation, Hoffman Estates, IL
60179 U.S.A.**

www.craftsman.com

TABLE OF CONTENTS

Warranty	page 2
Safety Symbols	pages 4-5
Safety Instructions	pages 6-12
Description	pages 12-13
Assembly	pages 13-14
Operation	pages 14-17
Application Tools	Pages 18-29
Maintenance	Pages 30-31
Troubleshooting	page 31
Parts List	page 32-34

CRAFTSMAN ONE YEAR LIMITED WARRANTY

FOR ONE YEAR from the date of purchase, this product is warranted against any defects in material or workmanship. With proof of purchase, defective product will be replaced free of charge. For warranty coverage details to obtain free replacement, visit the web site: www.craftsman.com

This warranty does not cover sandpaper, rasps or blades, which are expendable parts that can wear out from normal use within the warranty period. This warranty is void if this product is ever used while providing commercial services or if rented to another person.

This warranty gives you specific legal rights, and you may also have other rights which vary from state to state.

Sears Brands Management Corporation, Hoffman Estates, IL 60179

INTRODUCTION

SAVE THESE INSTRUCTIONS

This cordless Multi-Tool has many features for making its use more pleasant and enjoyable. Safety, performance, and dependability have been given top priority in the design of this product making it easy to maintain and operate.

⚠ DANGER: People with electronic devices, such as pacemakers, should consult their physician(s) before using this product. Operation of electrical equipment in close proximity to a heart pacemaker could cause interference or failure of the pacemaker.

⚠ WARNING: Some dust created by power sanding, sawing, grinding, drilling and other construction activities contains chemicals known to the state of California to cause cancer, birth defects or other reproductive harm. Some examples of these chemicals are:

- Lead from lead-based paints,
- Crystalline silica from bricks and cement and other masonry products, and
- Arsenic and chromium from chemically-treated lumber.

Your risk from these exposures varies, depending on how often you do this type of work. To reduce your exposure to these chemical: work in a well ventilated area, and work with approved safety equipment, such as those dust masks that are specially designed to filter out microscopic particles.

SAFETY SYMBOLS

The purpose of safety symbols is to attract your attention to possible dangers. The safety symbols and the explanations with them deserve your careful attention and understanding. The symbol warnings do not, by themselves, eliminate any danger. The instructions and warnings they give are no substitutes for proper accident prevention measures.

⚠ WARNING: Be sure to read and understand all safety instructions in this manual, including all safety alert symbols such as “DANGER,” “WARNING,” and “CAUTION,” before using this tool. Failure to following all instructions listed below may result in electric shock, fire, and/or serious personal injury.

SYMBOL SIGNAL MEANING

SAFETY ALERT SYMBOL: Indicates **DANGER, WARNING, OR CAUTION;** may be used in conjunction with other symbols or pictographs.

⚠ DANGER: Indicates a hazardous situation which, if not avoided, will result in death or serious injury.

⚠ WARNING: Indicates a hazardous situation which, if not avoided, could result in death or serious injury.

⚠ CAUTION: Indicates a hazardous situation which, if not avoided, could result in minor or moderate injury.

Damage Prevention and Information Messages

These inform the user of important information and/or instructions that could lead to equipment or other property damage if they are not followed. Each message is preceded by the word “**NOTICE**”, as in the example below:

NOTICE: Equipment and/or property damage may result if these instructions are not followed.











⚠ WARNING: To ensure safety and reliability, all repairs should be performed by a qualified service technician.



⚠ WARNING: The operation of any power tool can result in foreign objects being thrown into your eyes, which can result in severe eye damage. Before beginning power tool operation, always wear safety goggles or safety glasses with side shields and a full-face shield when needed. We recommend a Wide Vision Safety Mask for use over eyeglasses or standard safety glasses with side shields. Always use eye protection which is marked to comply with ANSI Z87.1

SAVE THESE INSTRUCTIONS

Some of these following symbols may be used on this tool. Please study them and learn their meaning. Proper interpretation of these symbols will allow you to operate the tool better and safer.

SYMBOL	NAME	DESIGNATION/EXPLANATION
V	Volts	Voltage
A	Amperes	Current
Hz	Hertz	Frequency (cycles per second)
W	Watt	Power
min	Minutes	Time
	Alternating Current	Type of current
	Direct Current	Type or a characteristic of current
n_0	No Load Speed	Rotational speed, at no load
	Class II Construction	Double-insulated construction
.../min	Per Minute	Revolutions, strokes, surface speed, orbits, etc., per minute
	Wet Conditions Alert	Do not expose to rain or use in damp locations.
	Read The Operator's Manual	To reduce the risk of injury, user must read and understand operator's manual before using this product.
	Eye Protection	Always wear safety goggles or safety glasses with side shields and a full face shield when operating this product.
	Safety Alert	Precautions that involve your safety.
	No-Hands Symbol	Failure to keep your hands away from the blade will result in serious personal injury.
	No-Hands Symbol	Failure to keep your hands away from the blade will result in serious personal injury.
	No-Hands Symbol	Failure to keep your hands away from the blade will result in serious personal injury.
	No-Hands Symbol	Failure to keep your hands away from the blade will result in serious personal injury.
	Hot Surface	To reduce the risk of injury or damage, avoid contact with any hot surface.

SAFETY INSTRUCTIONS

GENERAL POWER TOOL SAFETY WARNINGS

⚠ WARNING: Read all safety warnings and instructions. Failure to follow the warnings and instructions listed below may result in electric shock, fire, and/or serious personal injury.

Save all warnings and instructions for future reference.

The term “power tool” in all warnings listed below refers to corded power tools or battery-operated (cordless) power tools.

WORK AREA SAFETY

- **Keep your work area clean and well lit.** Cluttered or dark areas invite accidents.
- **Do not operate power tools in explosive environments, such as in the presence of flammable liquids, gases, or dust.** Power tools create sparks, which may ignite the dust or fumes.
- **Keep children and bystanders away while operating a power tool.** Distractions may cause you to lose control.

ELECTRICAL SAFETY

- **Power tool plugs must match the outlet. Never modify the plug in any way. Do not use any adapter plugs with grounded power tools.** Unmodified plugs and matching outlets will reduce the risk of electric shock.
- **Avoid body contact with grounded surfaces, such as pipes, radiators, ranges, and refrigerators.** There is an increased risk of electric shock if your body is grounded.
- **Do not expose power tools to rain or wet conditions.** Water entering a power tool will increase the risk of electric shock.
- **Do not abuse the cord. Never use the cord for carrying, pulling, or unplugging the power tool. Keep the cord away from heat, oil, sharp edge, or moving parts.** Damaged or entangled cords increase the risk of electric shock.
- **When operating a power tool outdoors, use an extension cord suitable for outdoor use.** Use of a cord suitable for outdoor use reduces the risk of electric shock.
- **If operating a power tool in a damp location is unavoidable, use a ground fault circuit interrupter (GFCI) protected supply.** Use of a GFCI reduces the risk of electric shock.

- Use only the battery and with the chargers listed:

BATTERY PACK	CHARGERS
320.11221	320.10006 320.14300 320.29497

PERSONAL SAFETY

- **Stay alert, watch what you are doing and use common sense when operating a power tool. Do not use the tool while tired or under the influence of drugs, alcohol, or medication.** A moment of inattention while operating power tools may result in serious personal injury.
- **Use personal protective equipment. Always wear eye protection.** Protective equipment such as a dust mask, non-skid safety shoes, hard hat, or hearing protection, used for appropriate conditions, will reduce personal injuries.
- **Prevent unintentional starting. Ensure that the switch is in the OFF position before connecting to a power source and/or battery, picking up or carrying the tool.** Carrying power tools with your finger on the switch or energizing power tools that have the switch turned on invites accidents.
- **Remove any adjusting key or wrench before turning the power tool on.** A wrench or a key left attached to a rotating part of the power tool may result in personal injury.
- **Do not overreach. Keep proper footing and balance at all times.** This enables better control of the power tool in unexpected situations.
- **Dress properly. Do not wear loose clothing or jewelry. Keep your hair, clothing and gloves away from moving parts.** Loose clothes, jewelry or long hair can be caught in moving parts.
- **If devices are provided for the connection of dust extraction and collection facilities, ensure that these are connected and properly used.** Use of these devices can reduce dust-related hazards.

POWER TOOL USE AND CARE

- **Do not force the power tool. Use the correct power tool for your application.** The correct power tool will do the job better and more safely at the rate for which it was designed.
- **Do not use the power tool if the switch does not turn it on and off.** Any power tool that cannot be controlled with the switch is dangerous and must be repaired.
- **Disconnect the plug from the power source and/or the battery from the power tool before making any adjustments, changing accessories, or storing power tools.** Such preventive safety measures reduce the risk of starting the power tool accidentally.

- **Store idle power tools out of the reach of children and do not allow persons unfamiliar with the power tool or these instructions to operate the power tool.** Power tools are dangerous in the hands of untrained users.
- **Maintain power tools. Check for misalignment or binding of moving parts, breakage of parts and any other condition that may affect the power tool operation. If damaged, have the power tool repaired before use.** Many accidents are caused by poorly maintained power tools.
- **Keep cutting tools sharp and clean.** Properly maintained cutting tools with sharp cutting edges are less likely to bind and are easier to control.
- **Use the power tool, accessories, tool bits, etc., in accordance with these instructions, taking into account the working conditions and the work to be performed.** Use of the power tool for operations different from those intended could result in a hazardous situation.

BATTERY TOOL USE AND CARE

- **Recharge only with the charger specified by the manufacturer.** A charger that is suitable for one type of battery pack may create a risk of fire when used with another battery pack.
- **Use power tools only with specifically designated battery packs.** Use of any other battery packs may create a risk of injury and fire.
- **When the battery pack is not in use, keep it away from other metal objects, such as paper clips, coins, keys, nails, screws, or other small metal objects that can make a connection from one terminal to another.** Shorting the battery terminals together may cause burns or a fire.
- **Under abusive conditions, liquid may be ejected from the battery; avoid contact. If contact accidentally occurs, flush with water. If liquid contacts eyes, seek medical help.** Liquid ejected from the battery may cause irritation or burns.

SERVICE

- **Have your power tool serviced by a qualified repair person using only identical replacement parts.** This will ensure that the safety of the power tool is maintained.
- **Follow instructions in the Maintenance section of this manual.** Use of unauthorized parts or failure to follow Maintenance instructions may create a risk of shock or injury.

SPECIFIC SAFETY RULES FOR CORDLESS MULTI-TOOL

- Never use your Multi-Tool to perform sanding or separating operations in wet conditions.
- Always wear eye protection.
- Always wear ear protection during extended periods of operation.
- Always wear a dust mask if the operation is dusty.
- Wear protective gloves when changing application accessories. Application accessories become hot after prolonged usage.
- Always inspect for and remove all nails, screws, staples, etc. before sanding.
- Always check walls and ceilings to avoid hidden power cables and pipes. A metal detector (available separately) is very helpful for this purpose.
- Whenever possible, use clamping devices or other suitable means to secure the workpiece to a firm surface.
- When working with the machine, always hold it firmly with both hands and provide for a secure stance. The power tool is guided more securely with both hands.
- Keep your workplace clean. Blends of materials are particularly dangerous. Dust from light alloys can burn or explode.
- Avoid unintentionally switching on the tool. Ensure that the on/off switch is in the OFF position before inserting the battery pack. Do not carry the power tool with your finger on the on/off switch or insert the battery pack into power tools that have the switch on.
- Do not open the battery. Danger of short-circuiting.
- Do not scrape wet or dampened materials (e.g. wallpaper) or on moist surfaces. Penetration of water into the machine increases the risk of an electric shock.
- Do not treat the surface to be worked with solvent-containing fluids. Materials being heated by the scraping can cause toxic vapors to develop.
- Exercise extreme caution when handling the scraper accessory. The accessory is very sharp; danger of injury.
- Only use application accessories in good condition. Do not use them if they are torn or worn.
- Only use application accessories in good condition. Do not use them if they are torn or worn.
- Do not restart a cutting operation in the workpiece. To resume a cutting operation: while keeping the tool from contacting the workpiece, allow the tool reach full speed and then carefully guide the cutting accessory into the cut.
- Keep your hands away from the cutting area. Do not reach under the material being cut.

- Hold power tools by their insulated gripping surfaces when performing an operation where the cutting tool may contact hidden wiring or its own cord. Contact with a “live” wire will make exposed metal parts of the tool “live” and shock the operator.



⚠ WARNING: Wear ear protection. Exposure to noise can cause hearing loss.

SAFETY RULES FOR CHARGER

⚠ WARNING: Read and understand all instructions. Failure to follow all instructions listed below may result in electric shock, fire, and/or serious personal injury.

⚠ WARNING: Before using the battery charger, read all instructions and cautionary markings in this manual and on the battery charger, the battery, and the product using the battery to prevent misuse of the products and possible injury or damage.

⚠ CAUTION: To reduce the risk of electric shock or damage to the charger and battery, charge only those lithium-ion rechargeable batteries specifically designated on your charger's label. Other types of batteries may burst, causing personal injury or damage.

- Do not use the charger outdoors or expose it to wet or damp conditions. Water entering the charger will increase the risk of electric shock.
- Use of an attachment not recommended or sold by the battery-charger manufacturer may result in a risk of fire, electric shock, or injury.
- Do not abuse the cord or charger. Never use the cord to carry the charger. Do not pull the charger cord to disconnect the plug from receptacle. Damage to the cord or charger could occur and create an electric shock hazard. Replace damaged cords immediately.
- Make sure that the cord is located so that it will not be stepped on, tripped over, come in contact with sharp edges or moving parts, or otherwise be subjected to damage or stress. This will reduce the risk of accidental falls, which could cause injury and damage to the cord and which could then result in electric shock.
- Keep the cord and charger from heat to prevent damage to housing or internal parts.
- Do not allow gasoline, oils, petroleum-based products, etc. to come in contact with plastic parts. These materials contain chemicals that can damage, weaken, or destroy plastic.

- An extension cord should not be used unless absolutely necessary. Use of an improper extension cord could result in a risk of fire and electric shock. If an extension cord must be used, make sure that:

The pins on plug of extension cord are the same number, size and shape as those of the plug on charger.

The cord is properly wired and in good electrical condition

The size is large enough for AC ampere rating of charger as specified below:

The Cord Length (Feet)	25'	50'	100'
Cord Size (AWG)	16	16	16

NOTICE: AWG = American Wire Gauge

- Do not operate the charger with a damaged cord or plug, as this could cause shorting and electric shock. If damaged, have the charger repaired or replaced by an authorized service technician at a Sears Service Center.
- Do not operate the charger if it has received a sharp blow, been dropped, or has otherwise been damaged in any way. Take it to an authorized service technician at a Sears Service Center for an electrical check to determine if the charger is in good working order.
- Do not disassemble the charger. Take it to an authorized service technician at a Sears Service Center when service or repair is required. Incorrect reassembly may result in a risk of electric shock or fire.
- Unplug the charger from the electrical outlet before attempting any maintenance or cleaning to reduce the risk of electric shock.
- Disconnect charger from the power supply when not in use. This will reduce the risk of electric shock or damage to the charger if metal items should fall into the opening. It will also help prevent damage to the charger during a power surge.
- Risk of electric shock. Do not touch the uninsulated portion of output connector or uninsulated battery terminal.
- Save these instructions. Refer to them frequently and use them to instruct others who may use this tool. If you lend this tool to someone else, also lend these instructions to them to prevent misuse of the product and possible injury.

IMPORTANT SAFETY INSTRUCTIONS

Save these instructions. This manual contains important safety and operating instructions for 12V Multi-Tool 320.61199.

Before using the Multi-Tool, read all instructions and cautionary markings on the battery charger, the battery and the product using the battery, as well as the operator's manuals for these products.

⚠ WARNING: When using electric appliances, basic precautions should always be followed, including the following.

- a) To reduce the risk of injury, close supervision is necessary when an appliance is used near children.
- b) Only use attachments recommended or sold by manufacturer.
- c) Do not use outdoors.
- d) For a portable appliance – To reduce the risk of electrical shock, do not put the Multi-Tool and Battery Pack in water or other liquid. Do not place or store appliance where or can fall or be pulled into a tub or sink.

DESCRIPTION

KNOW YOUR MULTI-TOOL (Fig. 1)

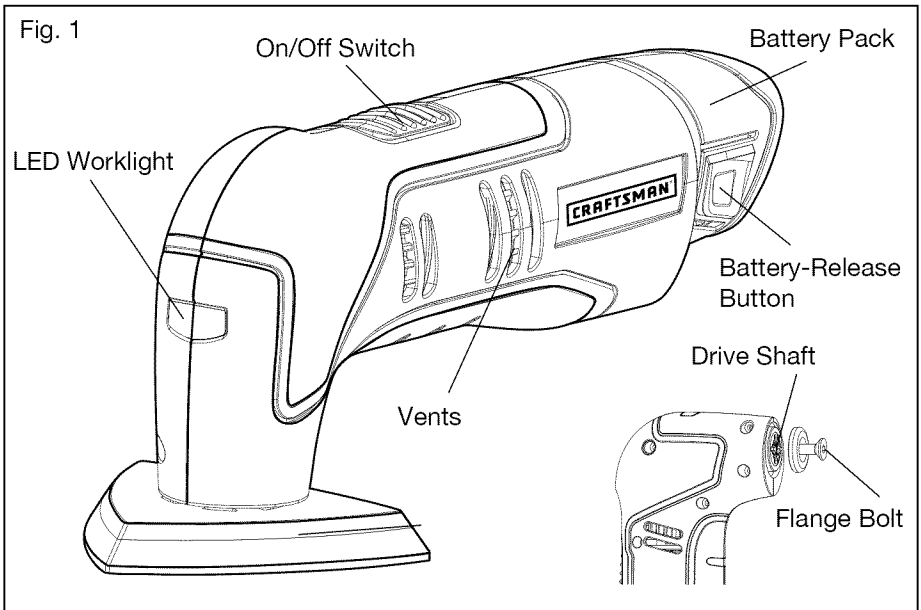

PRODUCT SEPCIFICATION	
Motor	12 Volt DC
Tool Weight (with battery)	1.8 lbs
Oscillation Rate	15000/Min
Oscillation Angle	±1.4 degrees
Battery Type	Lithium-Ion
Battery Voltage	12 Volt DC
Charger Input	120-Volts, 60 Hz AC only
Optimum Charging Temperature	32°F (0° C) -104°F (40°C)

⚠ WARNING: The safe use of this product requires an understanding of the information on the tool and in this operator's manual, as well as knowledge of the project you are attempting. Before using this product, familiarize yourself with all operating features and safety rules.

ASSEMBLY

⚠ WARNING: If any parts are broken or missing, do not attempt to plug in the power cord or operate the tool until the broken or missing parts are replaced. Failure to do so could result in possible serious injury.

⚠ WARNING: Do not attempt to modify this tool or create accessories not recommended for use with this tool. Any such alteration or modification is misuse and could result in a hazardous condition leading to possibly serious injury.

⚠ WARNING: To prevent accidental starting that could cause serious personal injury, always remove the battery pack from the tool when assembling parts.

UNPACKING

This product has been shipped completely assembled.







- Carefully remove the tool and accessories from the box. Make sure that all items listed in the packing list are included.
- Inspect the tool carefully to make sure that no breakage or damage occurred during shipping.
- Do not discard the packing material until you have carefully inspected and satisfactorily operated the tool.

PACKING LIST

Multi-Tool, straight edge flush cut blade, circular saw blade, hardened steel scraping blade, carbide circular adhesive removal blade, carbide triangular rasp, sanding plate and 9 pcs sandpaper, hex key, vacuum adaptor, operator's manual.

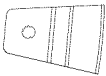
SELECTING THE APPLICATION ACCESSORY

⚠ WARNING: If any part is broken or missing, do not attempt to plug in the power cord or operate the tool until the broken or missing part is replaced. Failure to do so could result in possible serious injury.

ACCESSORY		MATERIALS
	Carbide Circular Blade	Grout, Plaster, Porous Concrete and Masonry
	Carbide Triangular Rasp	Hardened adhesives, Thinset, Wood, Masonry
	Scraper Blade	Paint & Varnish, Bonded Carpet, Soft Adhesives, Vinyl Flooring, wood and other floor coverings.
	Circular Saw Blade	Wood, Plastic, Drywall, Non-Ferrous Metals, thin Sheet Metal and other materials
	Flush Cut Blade	Wood, Plastic, Drywall, Soft Metals and other Materials
	Sanding Plate and Sandpaper	Bare or painted wood, plaster, and other surfaces, depending on sandpaper grit

OPERATION

LOW-BATTERY INDICATOR

If the LED worklight begins to rapidly and continuously flash when the switch on the tool is depressed, the battery-pack power has run out, and the battery pack should be recharged.

Unlike other battery pack types, Lithium-Ion battery packs deliver fade-free power for their entire run time. The tool will not experience a slow, gradual loss of power as you work. To signal that the battery pack is at the end of its run time and needs to be charged, the power to the tool will drop quickly.

NOTICE: The LED may also flash due to an overload or high temperature (see BATTERY PROTECTION).

BATTERY PROTECTION

The battery circuitry protects the battery pack from extreme temperature, over discharge, and over-charge. To protect the battery from damage and prolong its life, the battery pack circuitry will turn off the battery pack if it becomes overloaded or if the temperature becomes too high during use. This may happen in situations involving extremely high torque, binding, and stalling. This intelligent system will shut down your battery pack if its operating temperature exceeds 176°F (80°C) and will begin normal operation when it returns to 32°F (0°C) - 122°F (50°C).

The LED worklight will begin flash slowly if the battery circuitry detects a momentary overload.

NOTICE: The battery can automatically reset. If the LED continues to flash rapidly, it is indicating that the charge is substantially diminished. Place the battery into the charger for charging. (See LOW BATTERY INDICATOR, above.)

NOTICE: A significantly reduced run time after fully charging the battery pack indicates that the battery is near the end of its usable life and must be replaced.

COLD WEATHER OPERATION

This Lithium-Ion battery pack will provide optimal performance in temperatures between 32°F (0°C) and 104°F (40°C). When the battery pack is very cold, it may “pulse” for the first minute of use to warm itself. Put the battery pack on a tool and use the tool in a light application. After about a minute, the battery pack will have warmed itself and will operate normally.

WHEN TO CHARGE THE BATTERY PACK

It is not necessary to run down the battery pack charge before recharging. The Lithium-Ion battery can be charged at any time and will not develop a “memory” when charged after only a partial discharge.

Remove the battery pack from the tool when convenient for you and your job. “Top off” the battery pack charge by charging it for a time before starting a big job or long period of use.

Due to Lithium-Ion fade-free properties, the only time it is necessary to charge the Lithium-Ion battery pack is when the pack has reached the end of its charge. To signal the end of charge, power to the tool will drop quickly. Charge the battery pack as needed.

TO ATTACH BATTERY PACK (Fig. 2)

1. Make sure that the tool is “OFF.”
2. Align the raised rib on the battery pack with the grooves in the tool, and then attach the battery pack.

NOTICE: Make sure that the latch on the battery pack snaps into place and that the battery pack is secured to the tool before beginning operation.

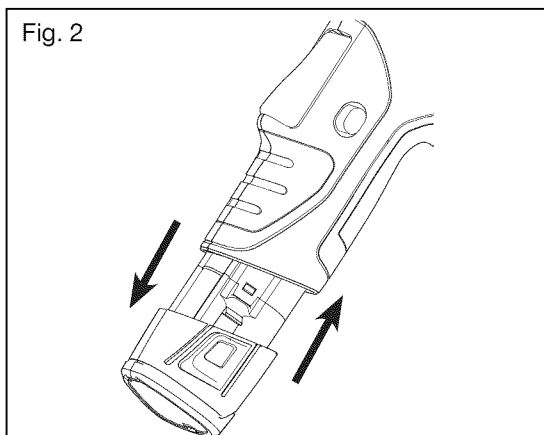

TO DETACH BATTERY PACK (Fig. 2)

1. Make sure that the tool is “OFF.”
2. Depress the battery-release buttons located on the both sides of the battery pack to release the battery pack.
3. Pull the battery pack out and remove it from the tool.

CAUTION: When placing the battery pack in the tool, be sure that the raised rib on battery pack aligns with the groove inside the tool and that the latches snap into place properly. Improper assembly of the battery pack can cause damage to internal components.

WARNING: Battery tools are always in operating condition; therefore, the on/off switch should always be in the “OFF” position when not in use or carrying the tool at your side.

ON/OFF SWITCH (Fig. 3)

To turn the tool ON, push the on/off switch forward. To turn it OFF, push the switch backward.

LED WORKLIGHT (Fig. 4)

The LED worklight, located on the front of the tool, will illuminate when the on/off switch is in the forward (ON) position. This provides additional light on the surface of the workpiece for operation in lower-light conditions. The LED worklight will turn off when the switch is slid backwards (OFF).

VACUUM ADAPTOR (Fig. 5)

Always connect the vacuum adaptor when sanding.

Remove the application tool before mounting the vacuum adaptor. To improve dust extraction from the working area, insert the dust-extraction adaptor into the rear of the tool, and connect the adaptor to a dust-extraction system or a suitable vacuum cleaner.

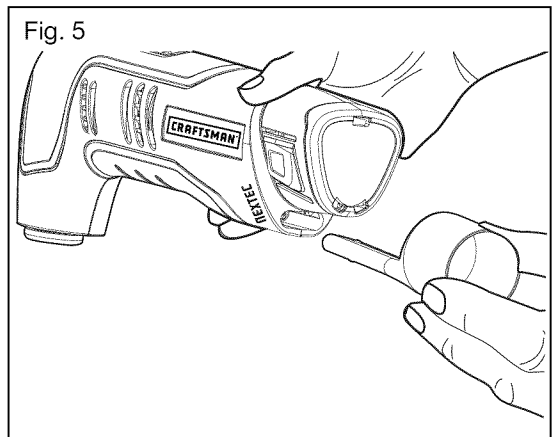
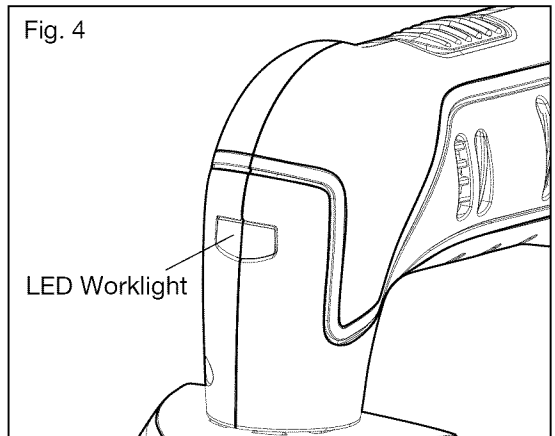
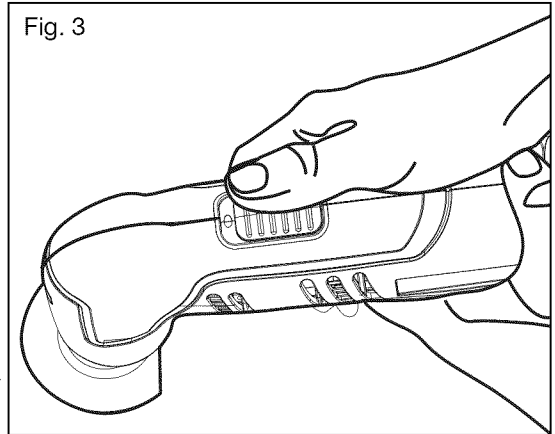

APPLICATION TOOLS

ATTACHING THE APPLICATION TOOL (Fig. 6, 7, 8, 9)

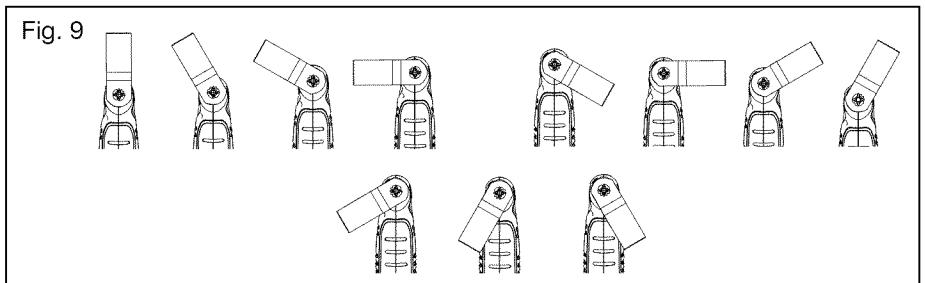
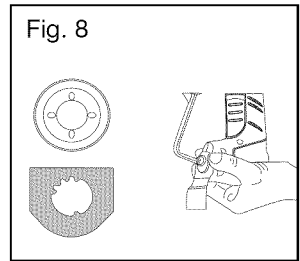
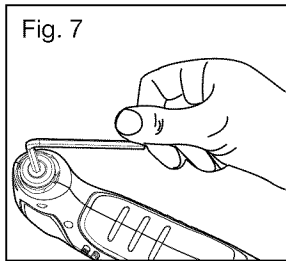
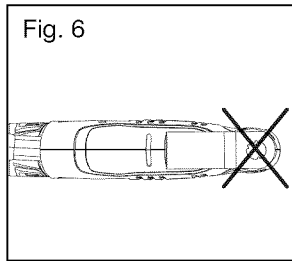

⚠ WARNING: Failure to remove the battery pack from the tool when assembling parts, making adjustments, or changing accessories could result in accidental starting causing possibly serious injury.

⚠ CAUTION: For all work or when changing application tools, always wear protective gloves. The sharp edges of the application tools will cause personal injury. Application tools can be very hot while working.

⚠ WARNING: Check that the application tools are correctly attached. Incorrect or insecurely fastened application tools can come loose during operation and cause a hazard.

⚠ WARNING: Do not attach the circular saw blade or the straight edge cutting blade facing backwards (Fig. 6), as operation in this position may cause serious injury.

1. Remove the battery pack from the Multi-Tool.
2. Loosen the flange bolt with the hex key provided (Fig. 7).
3. Ensure that the inner threads and the drive shaft are clean.
4. Align the grooves on the application tool with the four raised ribs on the drive shaft; put the application tool onto the drive shaft (Fig. 8).
5. With your gloved hand holding the blade, put on and tighten the flange bolt using the hex key.

NOTICE: Attach the application tool at the desired orientation for the task at hand. The shaft and the tools are configured so that the application tool can be attached every 30° around the shaft, from 0° to 330° (Fig. 9).

SANDPAPER KIT (67655) DESCRIPTION (Fig. 10)

- 9 pieces sandpaper (3 pieces each 60, 120 and 180 grit).
- Always apply to the compatible sanding plate (supplied with your Nextec Multi-tool 61199).
- Sandpaper kit is also compatible with the Bosch PMF180E and GOP 10.8VLi.

Fig. 10

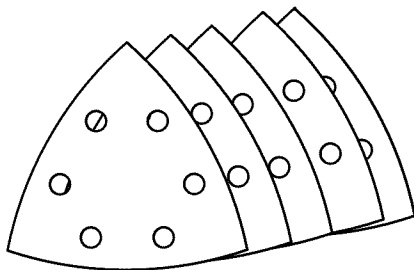

TO INSTALL THE SANDPAPER (Fig. 11)

⚠ WARNING: Check that the sanding plate and sandpaper are correctly attached. An incorrect or insecurely fastened application tool can come loose during operation and cause a hazard.

1. Follow the directions for Attaching the Application Tool to attach the sanding plate to the Multi-Tool.
2. Align the sandpaper with the sanding plate and use your hand to press it firmly onto the sanding plate.
3. Press the sandpaper firmly against a smooth surface for a short period, then switch on the tool. The burr will form a non-slip bond with the outer edge of the sandpaper felt. This will avoid premature wear.
4. If one point has become worn, pull off the sandpaper, turn it 120° and place it on the sanding plate again.

Fig. 11

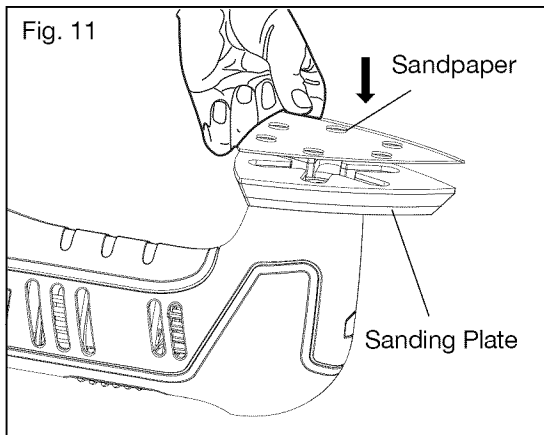

SANDING (Fig. 12)

⚠ WARNING: Do not touch the gear box after prolonged use; it could be very hot.

- The removal rate and the sanding pattern are determined by the choice of sanding sheet and the work surface.
 - Apply uniform sanding pressure to extend the life of the sanding sheets.
 - Intensifying the sanding pressure does not lead to an increase of the sanding capacity, but instead it increases wear on the machine and the sanding sheet.
 - Use only the tip or an edge of the sanding sheet for precise sanding of edges, corners and hard to reach areas.
 - When selectively sanding on one spot, the sanding sheet can heat up considerably. Remove the tool from the surface periodically to permit the sanding sheet to cool down.
 - A sanding sheet that has been used for metal should not be used for other materials.
 - Use only original Sears sanding accessories 67655.
 - For sanding, always connect dust extraction.
1. For Rough sanding use 40-80 grit paper.
 2. For Smooth sanding use 120-180 grit.

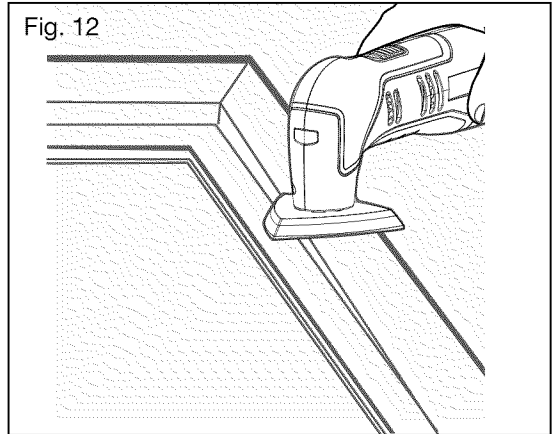

SAWING WITH THE CIRCULAR SAW BLADE (67651) DESCRIPTION (Fig. 13)

- High speed steel circular cutting blade.
- Designed for cutting wood, plastic, drywall, non-ferrous metals, thin sheet metal and other materials.
- The circular saw blade is also compatible with the Fein Multi-Master tool.

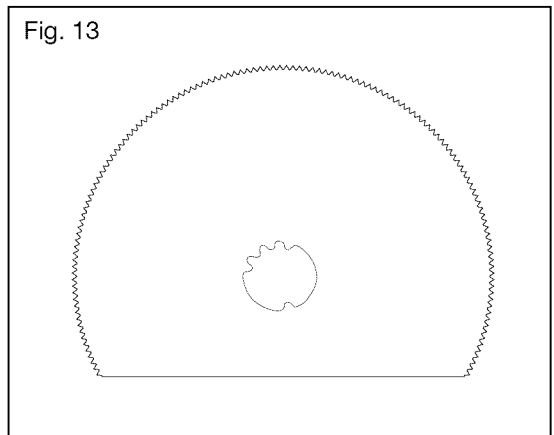

TO INSTALL THE CIRCULAR SAW BLADE

⚠ CAUTION: Wear protective gloves.

⚠ WARNING: Use sharp, undamaged saw blades only. Deformed, blunt saw blades or saw blades that are otherwise damaged can break.

⚠ WARNING: When sawing light building materials, observe the precautions and the recommendations of the material suppliers.

⚠ WARNING: Plunge cuts may only be applied to soft materials, such as wood, gypsum plaster boards, etc.

⚠ WARNING: The sawing teeth are very sharp. Do not touch during mounting and application.

⚠ WARNING: Do not attach the circular cutting blade facing backwards (Fig. 14), which may hurt the user.

1. Remove the battery pack from your multi-tool.
2. Loosen the flange bolt with the hex key provided (Fig. 15).
3. Ensure that the inner threads and the drive shaft are clean.
4. Align the grooves on the circular cutting blade with the four raised ribs on the drive shaft; put the blade onto the drive shaft (Fig. 16).
5. With your gloved hand holding the blade, put on and tighten the flange bolt using the hex key.

Fig. 14

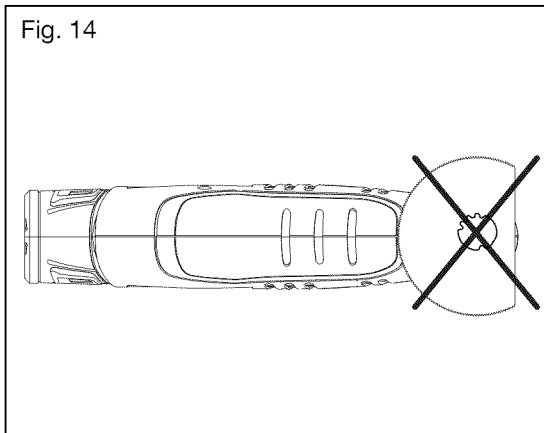

Fig. 15

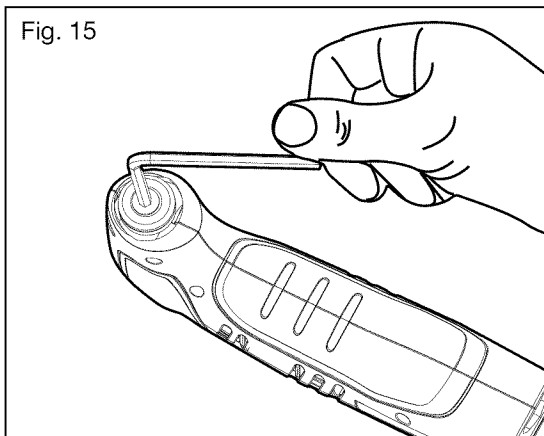
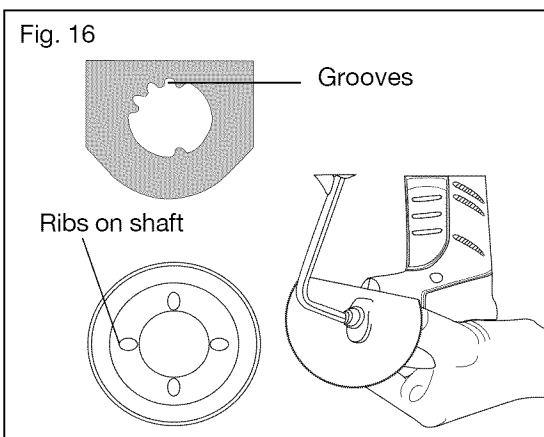

Fig. 16



NOTICE: The ribs on the shaft and the grooves in the accessory tools permit a firm connection of the accessory tools in increments of 30° around the shaft (Fig. 17) Apply the application tool in the orientation appropriate to the task at hand.

CUTTING WITH THE CIRCULAR SAW BLADE(Fig. 18)

1. Insert the battery pack into the multi-tool.
2. Securely clamp the workpiece if necessary.
3. Draw the cutting lines on the workpiece.
4. Apply the blade to the workpiece.
5. Switch on the tool and apply appropriate pressure to make the cut.

CARBIDE CIRCULAR BLADE (67650) DESCRIPTION (Fig. 19)

The Carbide Circular Blade is designed to cut out the grout around wall tiles. It can also be used to cut plaster, porous concrete and masonry.

- Carbide-tipped, circular grout disc.
- Designed for grout, plaster, masonry or porous concrete removal around the wall tiles.
- Compatible with the Nextec Multi-Tool and Fein Multi-Master.

Fig. 17

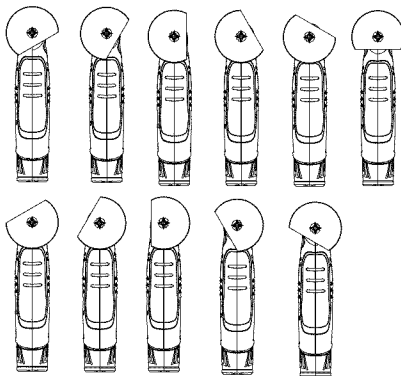

Fig. 18

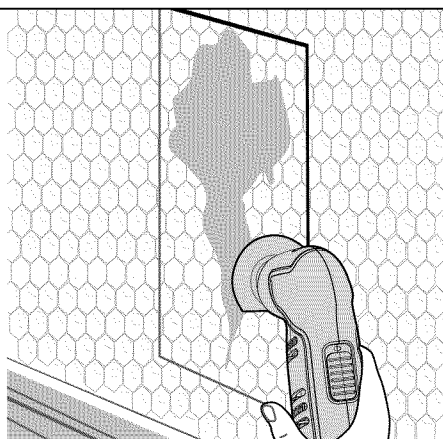
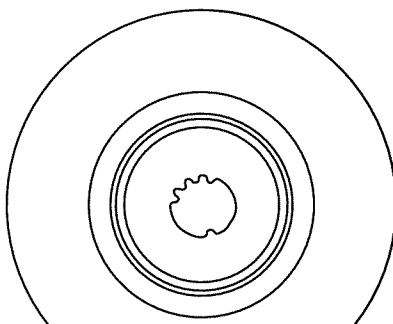

Fig. 19



TO INSTALL THE CARBIDE CIRCULAR BLADE

⚠ Caution: Wear protective gloves.

1. Remove the battery pack from your multi-tool.
2. Loosen the flange bolt with the hex key provided (Fig. 20).
3. Ensure that the inner threads and the drive shaft are clean.
4. Align the grooves on the circular grout disc with the four raised ribs on the drive shaft; put the disc onto the drive shaft (Fig. 21).
5. With your gloved hand holding the disc, put on and tighten the flange bolt using the hex key.

NOTICE: The ribs on the shaft and the grooves in the accessory tools permit a firm connection of the accessory tools in increments of 30° around the shaft (Fig. 22) Apply the application tool in the orientation appropriate to the task at hand.

Fig. 20

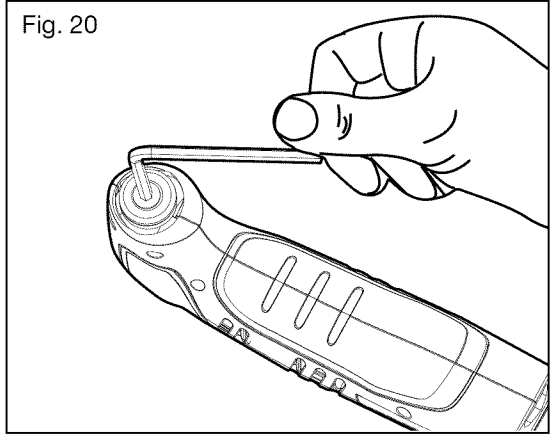

Fig. 21

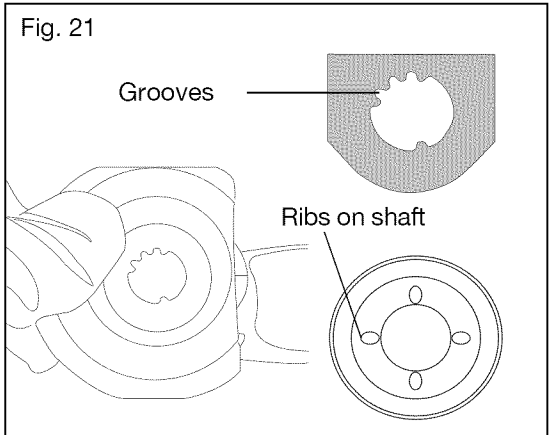
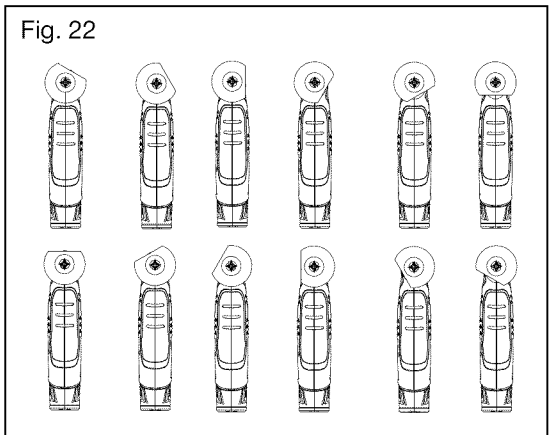
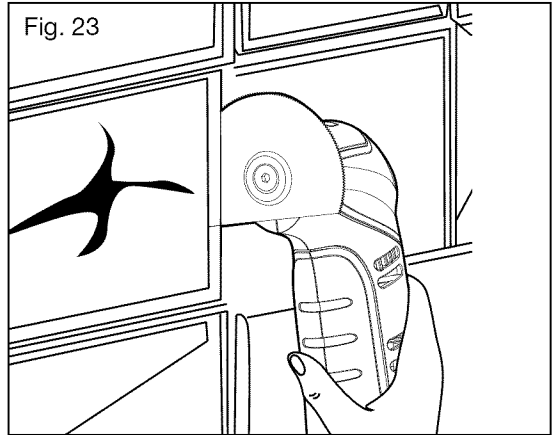

Fig. 22



CUTTING WITH THE CARBIDE CIRCULAR BLADE (Fig. 23)

1. Insert the battery pack into the multi-tool.
2. Draw the cutting lines on the workpiece.
3. Place the carbide circular blade against the workpiece at a 90° angle.
4. Switch on the tool, cut out the grout around the wall tile, then use a hand chisel to remove the tile.



NOTICE: When separating wall tiles, take into consideration that the application tools/ accessories wear heavily when used for longer periods of time.

SCRAPER BLADE (67652) DESCRIPTION (Fig. 24)

- Steel scraping blade designed for paint & varnish, bonded carpet, soft adhesives, vinyl flooring, wood and other floor coverings.
- Scraper blade is also compatible with the Fein Multi-Master tool.

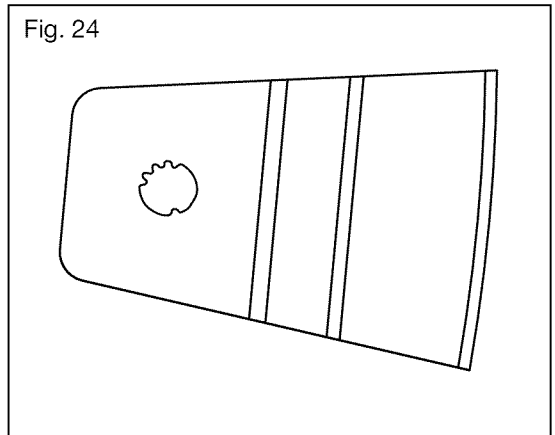

TO INSTALL THE SCRAPER BLADE

⚠ Caution: Wear protective gloves.

⚠ CAUTION: For all work or when changing application tool, always wear protective gloves. The sharp edges of the application tool will cause personal injury. Application tool can be very hot while working.

⚠ WARNING: Check that the application tool is correctly attached. Incorrect or insecurely fastened application tool can come loose during operation and cause a hazard.

1. Remove the battery pack from your multi-tool.
2. Loosen the flange bolt with the hex key provided (Fig. 25).
3. Ensure that the inner threads and the drive shaft are clean.
4. Align the grooves on the scraper blade with the four raised ribs on the drive shaft; put the blade onto the drive shaft (Fig. 26).
5. With your gloved hand holding the blade, put on and tighten the flange bolt using the hex key.

NOTICE: The ribs on the shaft and the grooves in the accessory tools permit a firm connection of the accessory tools in increments of 30° around the shaft (Fig. 27) Apply the application tool in the orientation appropriate to the task at hand.

Fig. 25

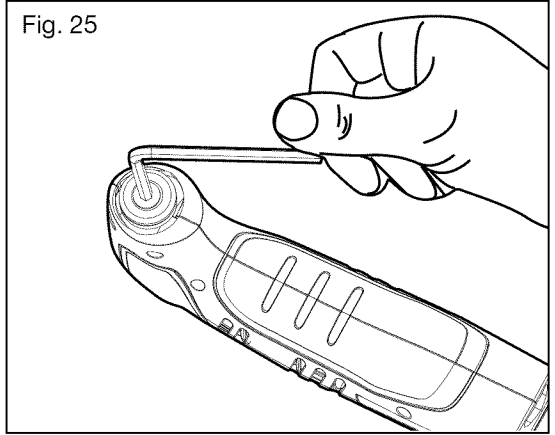

Fig. 26

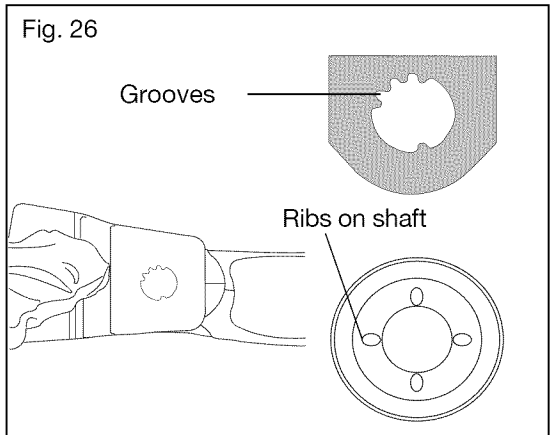
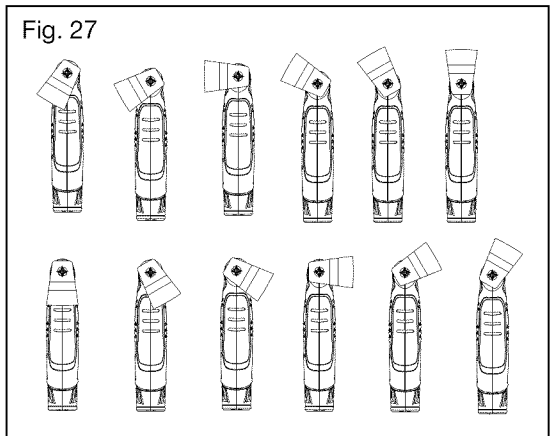

Fig. 27



USING THE SCRAPER BLADE (Fig. 28)

1. Insert the battery pack into the multi-tool.
2. To scrape, put the tool on the workpiece at a flat angle (not more than 20°), and apply only light pressure so as to not cut into the surface.
3. To cut and remove carpet, place the Scraper Blade vertically on the workpiece, switch the tool on, and cut the carpet. Then place the scraper blade between the carpet and the floor to the coverings and adhesive residue off.

Fig. 28

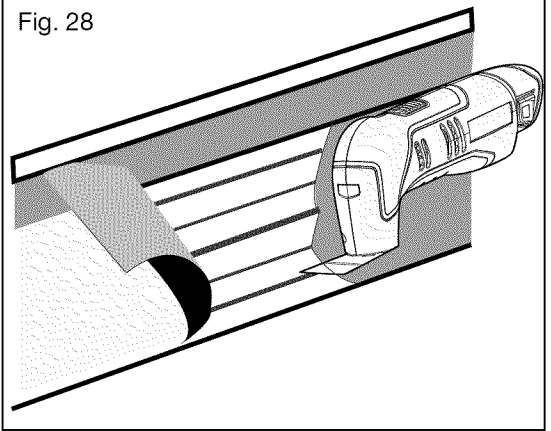
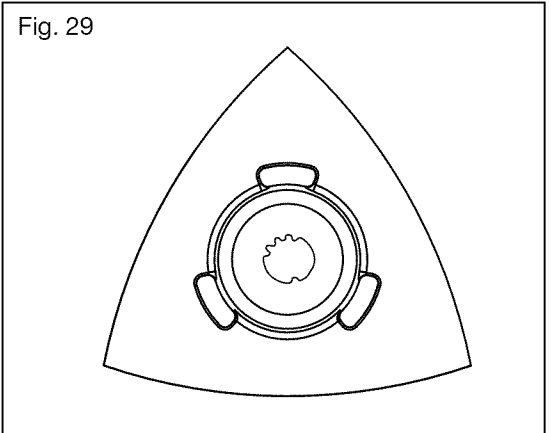

Fig. 29



CARBIDE TRIANGULAR RASP (67654) DESCRIPTION (Fig. 29)

- Carbide tipped triangular grout rasp.
- Designed for grout, masonry, thinset, wood and removal of hardened adhesives on the wall tiles.
- Triangular rasp is also compatible with the Fein Multi-Master tool.

Fig. 30

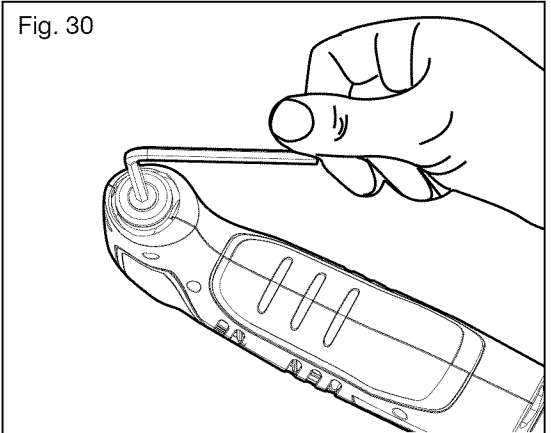

TO INSTALL THE CARBIDE TRIANGULAR RASP

⚠ Caution: Wear protective gloves.

1. Remove the battery pack from your multi-tool.
2. Loosen the flange bolt with the hex key provided (Fig. 30).

3. Ensure that the inner threads and the drive shaft are clean.
4. Align the grooves on the carbide triangular rasp with the four raised ribs on the drive shaft; put the disc onto the drive shaft (Fig. 31).
5. With your gloved hand holding the disc, put on and tighten the flange bolt using the hex key.

NOTICE: The ribs on the shaft and the grooves in the accessory tools permit a firm connection of the accessory tools in increments of 30° around the shaft (Fig. 32). Apply the application tool in the orientation appropriate to the task at hand.

USING THE CARBIDE TRIANGULAR RASP (Fig. 33)

1. Insert the battery pack into the multi-tool.
2. Draw the cutting lines on the workpiece.
3. Put the rasp flat against the workpiece and apply appropriate pressure.
4. Switch on the tool, remove any hardened adhesive or grout on the surface of the wall tiles.

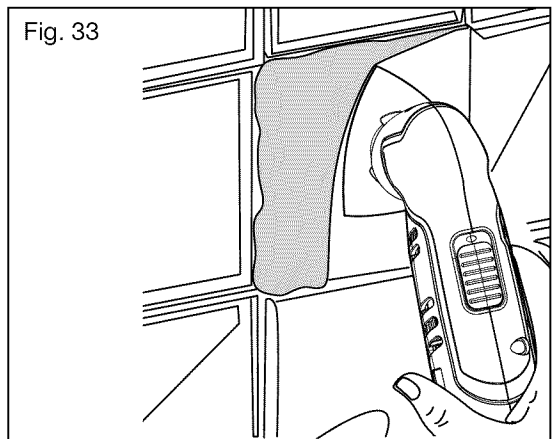
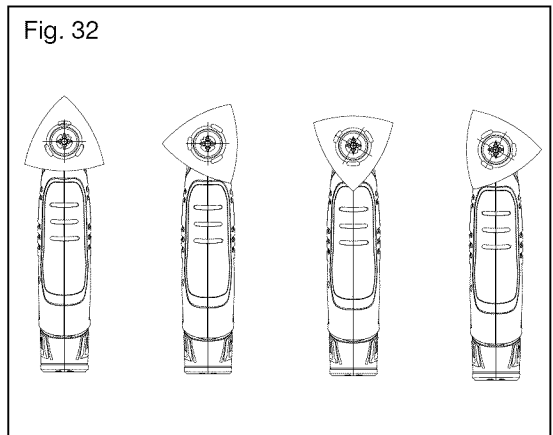
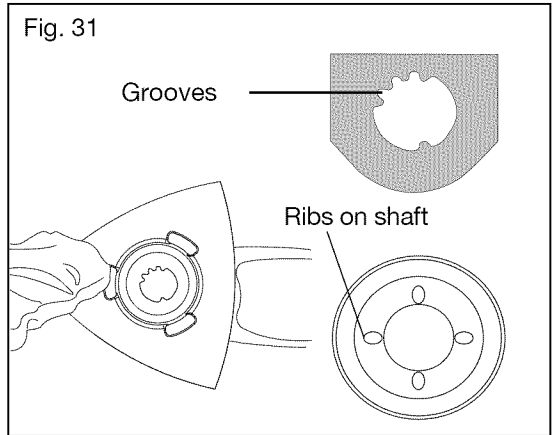

FLUSH CUT BLADE (67653) DESCRIPTION (Fig. 34)

- Bi-metal, straight-edge, flush-cut blade.
- Designed for cutting wood, plastic, drywall, soft metal and other materials.
- Can plunge and saw with a slight pendulum action in wood.
- Flush Cut blade is also compatible with the Fein Multi-Master tool.

Fig. 34

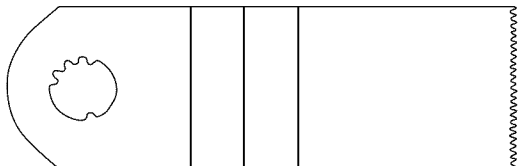

TO INSTALL THE FLUSH CUT BLADE

⚠ CAUTION: Wear protective gloves.

⚠ WARNING: Do not attach the flush-cut blade facing backwards (Fig. 35), which may hurt the user.

1. Remove the battery pack from your multi-tool.
2. Loosen the flange bolt with the hex key provided (Fig. 36.)
3. Ensure that the inner threads and the drive shaft are clean.

Fig. 35

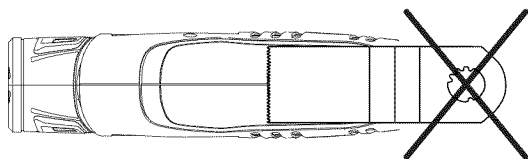
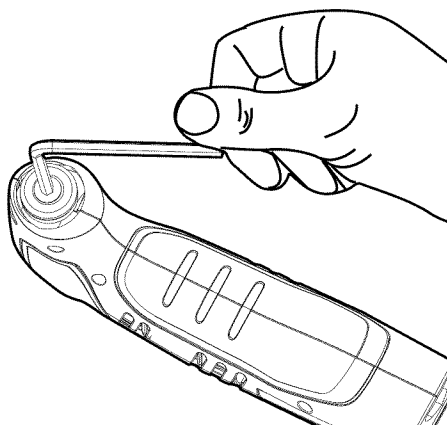

Fig. 36



4. Align the grooves on the flush-cut blade with the four raised ribs on the drive shaft; put the blade onto the drive shaft (Fig. 37).
5. With your gloved hand holding the blade, put on and tighten the flange bolt using the hex key.

NOTICE: The ribs on the shaft and the grooves in the accessory tools permit a firm connection of the accessory tools in increments of 30° around the shaft (Fig. 38) Apply the application tool in the orientation appropriate to the task at hand.

USING THE FLUSH CUT BLADE (Fig. 39)

1. Insert the battery pack into the multi-tool.
2. Clamp the workpiece securely.
3. Draw the cutting lines on the workpiece.
4. Put the blade along the line.
5. Switch on the tool, and apply with appropriate pressure until the blade cuts to the depth needed according to the scale on the blade.

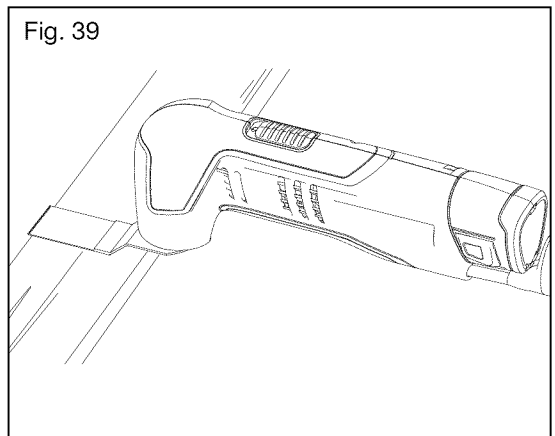
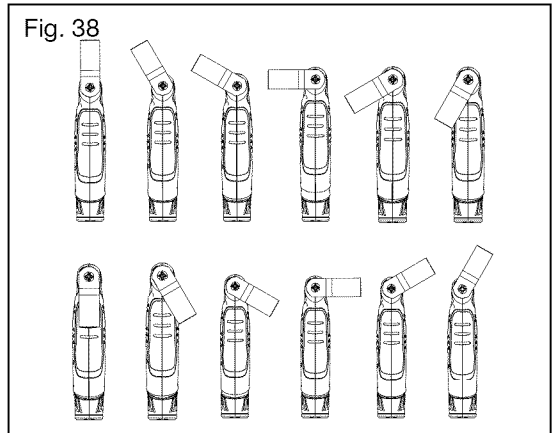
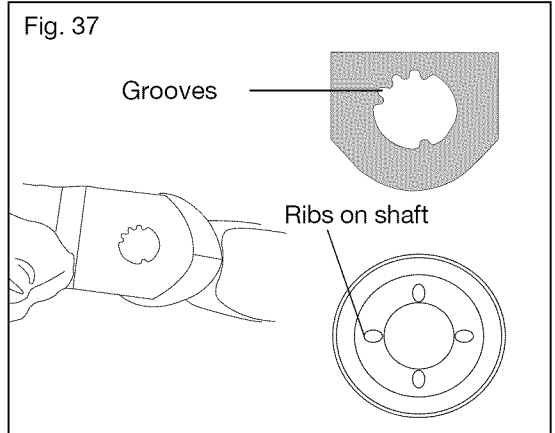

MAINTENANCE

⚠ WARNING: To avoid serious personal injury, always remove the battery pack from the tool when cleaning or performing any maintenance.

⚠ WARNING: When servicing, use only identical Craftsman replacement parts. Use of any other parts may create a hazard or cause product damage.

⚠ WARNING: It is not recommended to use compressed dry air as cleaning method of the tool. If cleaning with compressed air is the only method to apply, always wear safety goggles or safety glasses with side shields when using compressed air to clean the tool. If the operation is dusty, also wear a dust mask.

GENERAL MAINTENANCE

Avoid using solvents when cleaning plastic parts. Most plastics are susceptible to damage from various types of commercial solvents and may be damaged by their use. Use clean cloths to remove dirt, dust, oil, grease, etc.

⚠ WARNING: Do not at any time let brake fluids, gasoline, petroleum-based products, penetrating oils, etc. to come in contact with plastic parts. Chemicals can damage, weaken or destroy plastic which may result in serious personal injury.

⚠ WARNING: When servicing, use only identical Craftsman replacement parts. Use of any other parts may create a hazard or cause product damage. To ensure safety and reliability, all repairs should be performed by a qualified service technician at a Sears Service Center.

BATTERIES:

The battery pack is equipped with Lithium-Ion rechargeable batteries. The duration of use from each charge will depend on the type of work performed.

The batteries in this tool have been designed to provide maximum trouble-free life. Like all batteries, they will eventually wear out. Do not disassemble the battery pack or attempt to replace the batteries. Handling of the batteries, especially when wearing rings and jewelry, could result in a serious burn.

To obtain the longest possible battery life, read and understand the operator's manual.

- It is good practice to unplug the Charger/Adaptor and remove the Lithium-Ion battery pack when not in use.

For Lithium-Ion battery pack storage longer than 30 days:

- Store the Lithium-Ion battery pack where the temperature is below 80°F (26°C) and free of moisture.
- Store Lithium-Ion battery packs in a 30%-50% charged condition.
- Every six months of storage, fully charge the Lithium-Ion battery pack.
- Exterior may be cleaned with a cloth or soft non-metallic brush.

BATTERY PACK REMOVAL AND PREPARATION FOR RECYCLING

To preserve natural resources, please recycle or dispose of batteries properly. This product contains lithium-ion batteries. Local, state, or federal laws may prohibit disposal of lithium-ion batteries in ordinary trash. Consult your local waste authority for information regarding available recycling and/or disposal options.



⚠ WARNING: Upon removal of the battery pack for disposal or recycling, cover the battery pack's terminals with heavy-duty adhesive tape. Do not attempt to destroy or disassemble battery pack or remove any of its components. Lithium-Ion batteries must be recycled or disposed of properly. Also, never touch both terminals with metal objects and/or body parts as short circuit may result. Keep away from children. Failure to comply with these warnings could result in fire and/or serious injury.

TROUBLESHOOTING

PROBLEM	CAUSE	SOLUTION
The tool does not work	Battery is depleted	Charge the battery
Motor overheating	Be sure cooling vents are free from dust and obstacles	Clean, clear vents. Do not cover with hand during operation

PARTS LIST

12 VOLT LITHIUM-ION CORDLESS MULTI-TOOL MODEL NUMBER 320.61199

The Model Number will be found on the Nameplate attached to the handle of the Multi-Tool. Always mention the Model Number when ordering parts for this tool.

To order parts, call 1-800-469-4663.

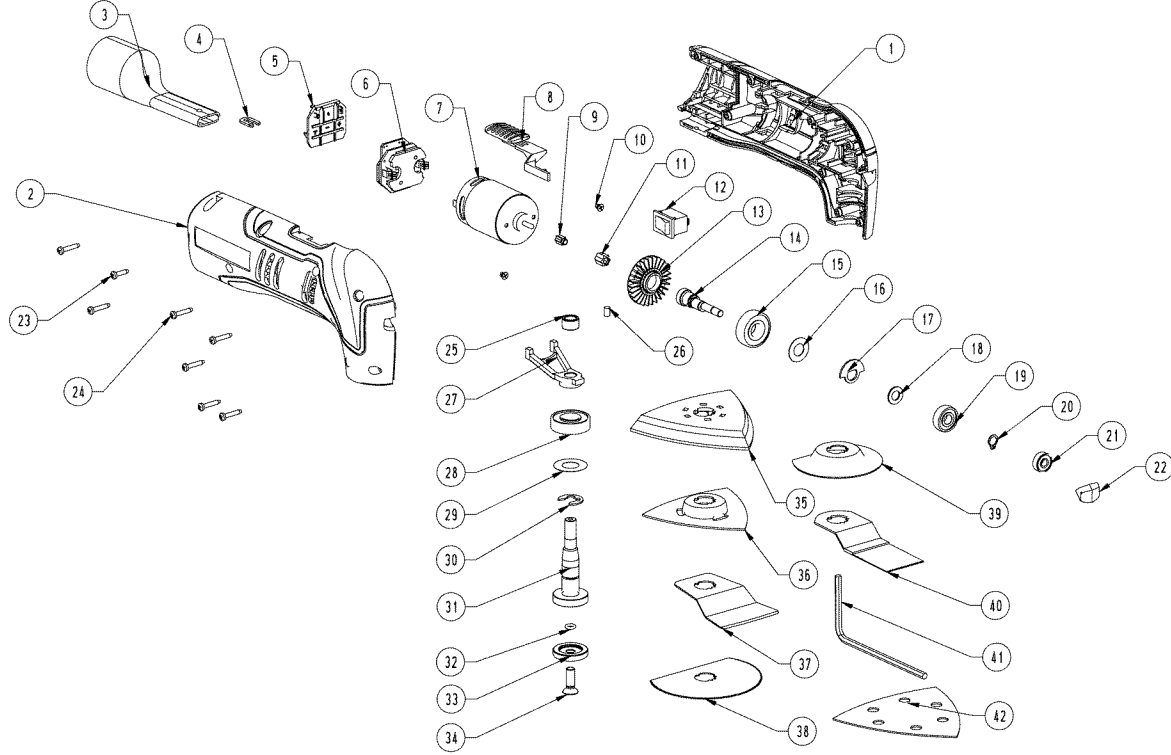

PARTS LIST

12 VOLT LITHIUM-ION CORDLESS MULTI-TOOL MODEL NUMBER 320.61199

The Model Number will be found on the Nameplate attached to the handle of the Multi-Tool. Always mention the Model Number when ordering parts for this tool.

To order parts, call 1-800-469-4663.

No	Part No	Part Name	QTY
1	3320775000	Left Housing	1
2	3320774000	Right Housing	1
3	3124550000	Vacuum Adapter	1
4	3704254000	Handle Hoop	1
5	3402298000	Contact Receptacle ASSY	1
6	4890548000	PCB Assembly	1
7	2730009000	DC Motor	1
8	3124551000	Switch Actuator	1
9	3551431000	Connector	1
10	5620062000	Screw	2
11	3125163000	Spring Connector	1
12	4870385000	Rocker Switch	1
13	3125160000	Fan	1
14	3551430000	Eccentric Shaft	1
15	5700048000	Ball Bearing	1
16	5650216000	Plain Washer	1
17	3704682000	Counterweight	1
18	3700352000	Washer	1
19	5700205000	Ball Bearing	1
20	5660144000	Circlips For Shaft	1
21	5700197000	Ball Bearing	1
22	3124549000	LED Cover	1
23	5610012000	Tapping Screw	1
24	5610013000	Tapping Screw	7

No	Part No	Part Name	QTY
25	5700040000	Oil Impreging Bearing	1
26	3121038000	Rubber Stick	1
27	3420911000	Lever	1
28	5700014000	Ball Bearing	1
29	5650044000	Plain Washer	1
30	5660010000	E Ring	1
31	3551273000	Spindle	1
32	5690018000	O Ring	1
33	5650300000	Washer	1
34	5620416000	Hexagon Socket Screw	1
35	3320814000	Base Plate Set	1
36	3810456000	Carbide Triangular RASP	1
37	3810453000	Scraper Blade	1
38	3810454000	Circular Saw Blade	1
39	3810452000	Carbide Circular Blade	1
40	3810455000	Flush Cut Blade	1
41	5680164000	Inner Hexagon Spanner	1
42	2820442000	Sanding Papers-9pcs	1

NOTICE

