

PRO-FORM[®]

390 E

Model No. 831.23943.5

Serial No. _____

Write the serial number in the space above for reference.

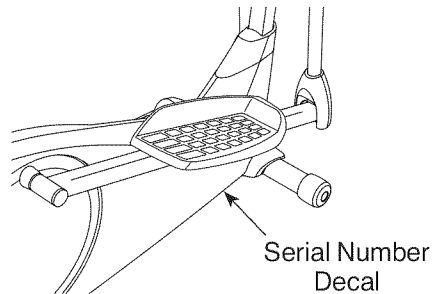

- Assembly
- Operation
- Maintenance
- Part List and Drawing

Sears, Roebuck and Co.
Hoffman Estates, IL 60179

CAUTION

Read all precautions and instructions in this manual before using this equipment. Keep this manual for future reference.

ELLIPTICAL EXERCISER

User's Manual

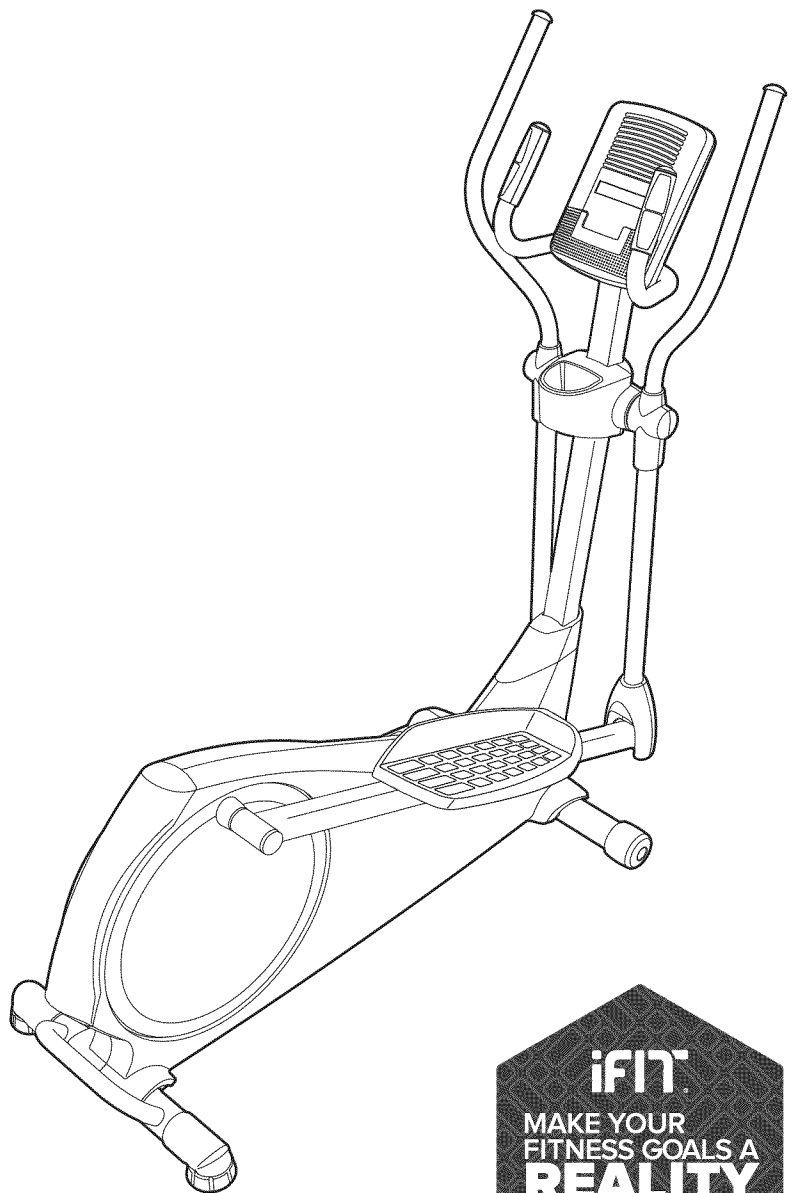

TABLE OF CONTENTS



WARNING DECAL PLACEMENT	2
IMPORTANT PRECAUTIONS	3
BEFORE YOU BEGIN	4
PART IDENTIFICATION CHART	5
ASSEMBLY	6
HOW TO USE THE ELLIPTICAL	14
MAINTENANCE AND TROUBLESHOOTING	18
EXERCISE GUIDELINES	20
PART LIST	21
EXPLODED DRAWING	22
HOW TO CONTACT CUSTOMER CARE	Back Cover
90 DAY FULL WARRANTY	Back Cover

WARNING DECAL PLACEMENT

This drawing shows the location(s) of the warning decal(s). **If a decal is missing or illegible, call 1-888-533-1333 and request a free replacement decal. Apply the decal in the location shown.**
Note: The decal(s) may not be shown at actual size.

WARNING

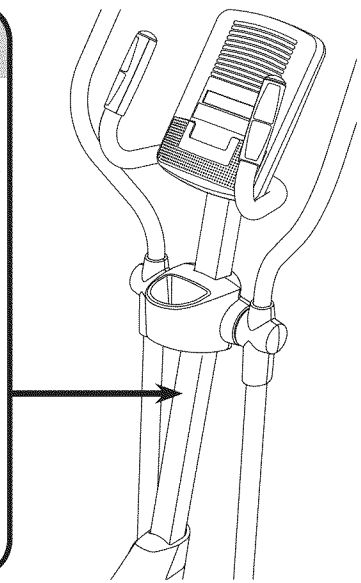
- Misuse of this machine may result in serious injury.
- Read user's manual prior to use and follow all warnings and instructions.
- Do not allow children on or around machine.
- Pedals continue to spin when you stop pedaling.
- Spinning pedals can cause injury.
- Reduce pedal speed in a controlled manner.
- User weight must not exceed 250 pounds.
- Replace label if damaged, illegible, or removed.



IMPORTANT PRECAUTIONS

⚠ WARNING: To reduce the risk of serious injury, read all important precautions and instructions in this manual and all warnings on your elliptical before using your elliptical. Sears assumes no responsibility for personal injury or property damage sustained by or through the use of this product.

1. It is the responsibility of the owner to ensure that all users of the elliptical are adequately informed of all precautions.
2. Before beginning any exercise program, consult your physician. This is especially important for persons over age 35 or persons with pre-existing health problems.
3. The elliptical is not intended for use by persons with reduced physical, sensory, or mental capabilities or lack of experience and knowledge, unless they are given supervision or instruction about use of the elliptical by someone responsible for their safety.
4. Use the elliptical only as described in this manual.
5. The elliptical is intended for home use only. Do not use the elliptical in a commercial, rental, or institutional setting.
6. Keep the elliptical indoors, away from moisture and dust. Do not put the elliptical in a garage or covered patio, or near water.
7. Place the elliptical on a level surface, with at least 3 ft. (0.9 m) of clearance in the front and rear of the elliptical and 2 ft. (0.6 m) on each side. To protect the floor or carpet from damage, place a mat under the elliptical.
8. Inspect and properly tighten all parts each time the elliptical is used. Replace any worn parts immediately.
9. Keep children under age 13 and pets away from the elliptical at all times.
10. The elliptical should not be used by persons weighing more than 250 lbs. (113 kg).
11. Wear appropriate clothes while exercising; do not wear loose clothes that could become caught on the elliptical. Always wear athletic shoes for foot protection while exercising.
12. Hold the handlebars or the upper body arms when mounting, dismounting, or using the elliptical.
13. The heart rate monitor is not a medical device. Various factors may affect the accuracy of heart rate readings. The heart rate monitor is intended only as an exercise aid in determining heart rate trends in general.
14. The elliptical does not have a freewheel; the pedals will continue to move until the flywheel stops. Reduce your pedaling speed in a controlled way.
15. Keep your back straight while using the elliptical; do not arch your back.
16. Over exercising may result in serious injury or death. If you feel faint, if you become short of breath, or if you experience pain while exercising, stop immediately and cool down.

BEFORE YOU BEGIN

Thank you for purchasing the PROFORM® 390 E elliptical. The 390 E elliptical provides an array of features designed to make your workouts at home more effective and enjoyable.

For your benefit, read this manual carefully before you use the elliptical. If you have questions after reading this manual, please see the back cover of this

manual. To help us assist you, note the product model number and serial number before contacting us. The model number and the location of the serial number decal are shown on the front cover of this manual.

Before reading further, please familiarize yourself with the parts that are labeled in the drawing below.

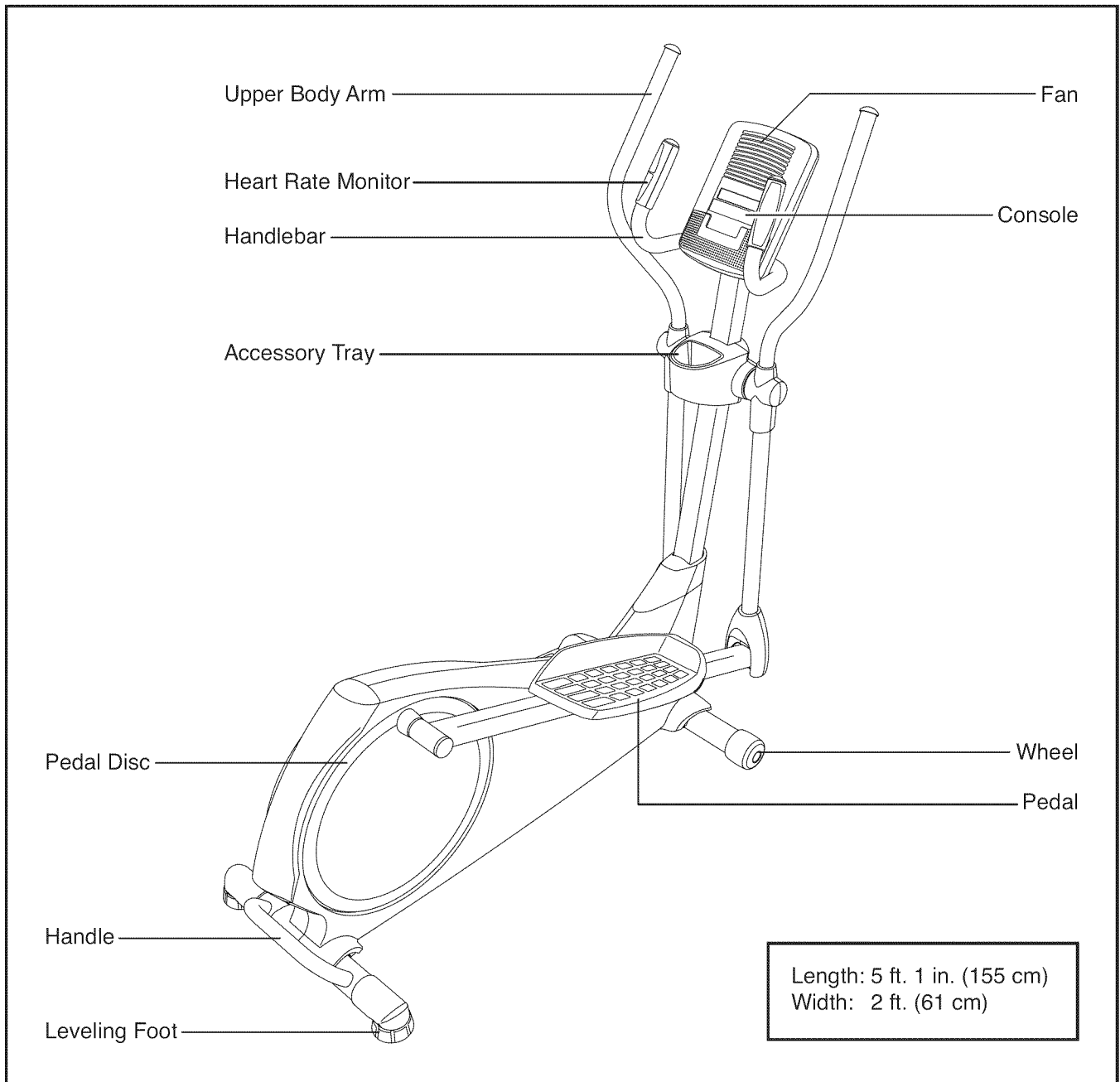

PART IDENTIFICATION CHART

Use the drawings below to identify the small parts needed for assembly. The number in parentheses below each drawing is the key number of the part, from the PART LIST near the end of this manual. The number following the key number is the quantity needed for assembly. **Note: If a part is not in the hardware kit, check to see if it has been preassembled. Extra parts may be included. If a part is missing, call 1-888-533-1333.**

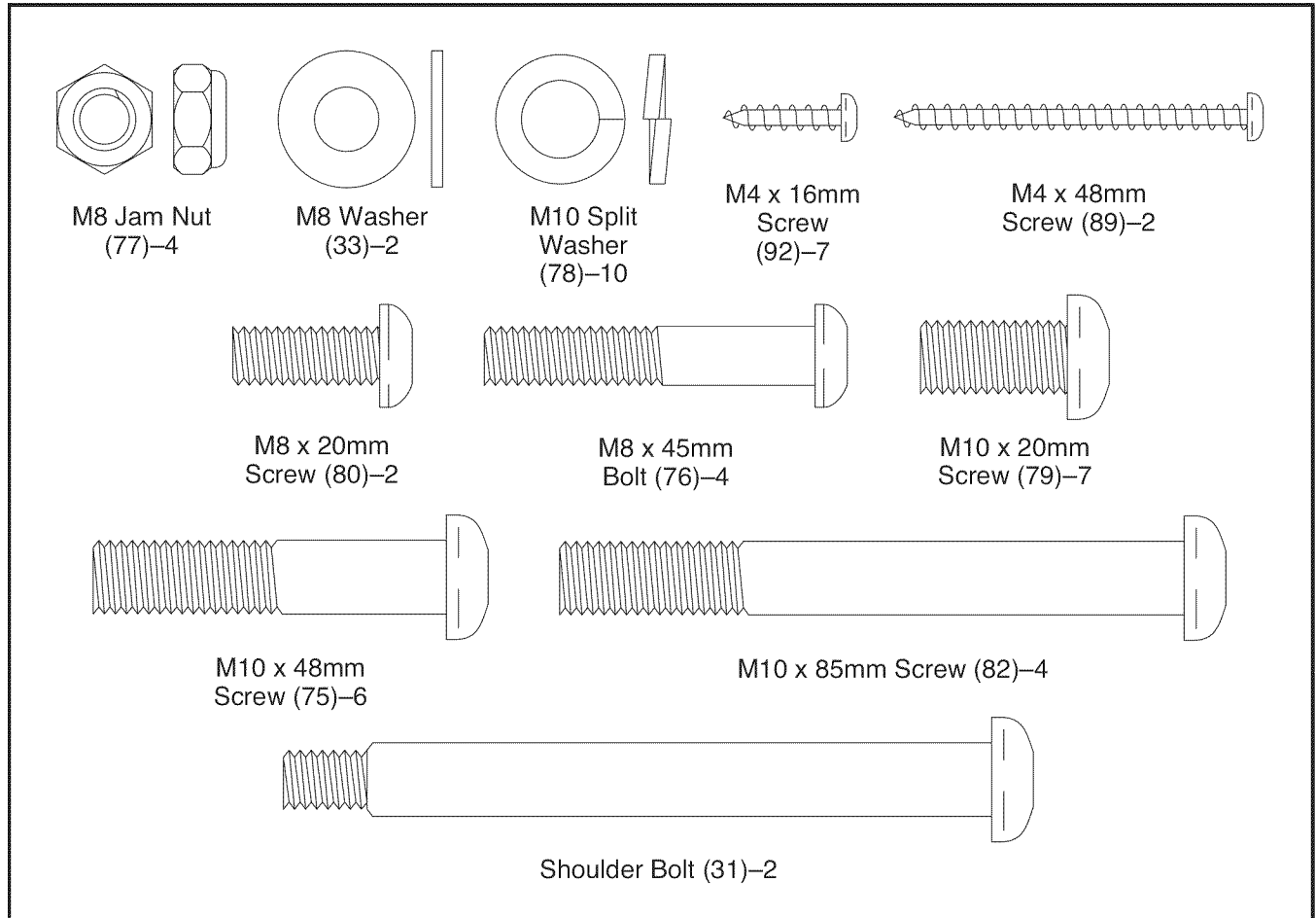

ASSEMBLY

- Assembly requires two persons.
- Place all parts in a cleared area and remove the packing materials. Do not dispose of the packing materials until you finish all assembly steps.
- Left parts are marked “L” or “Left” and right parts are marked “R” or “Right.”
- To identify small parts, see page 5.

- In addition to the included tool(s), assembly requires the following tool(s):

one Phillips screwdriver



Assembly may be easier if you have a set of wrenches. To avoid damaging parts, do not use power tools.

1. **Go to www.proformservice.com/registration on your computer and register your product.**

- activates your warranty
- saves you time if you ever need to contact Customer Care
- allows us to notify you of upgrades and offers

Note: If you do not have Internet access, call 1-888-533-1333 and register your product.

2. While a second person lifts the rear of the Frame (1), attach the Rear Stabilizer (70) to the Frame with two M10 x 85mm Screws (82).

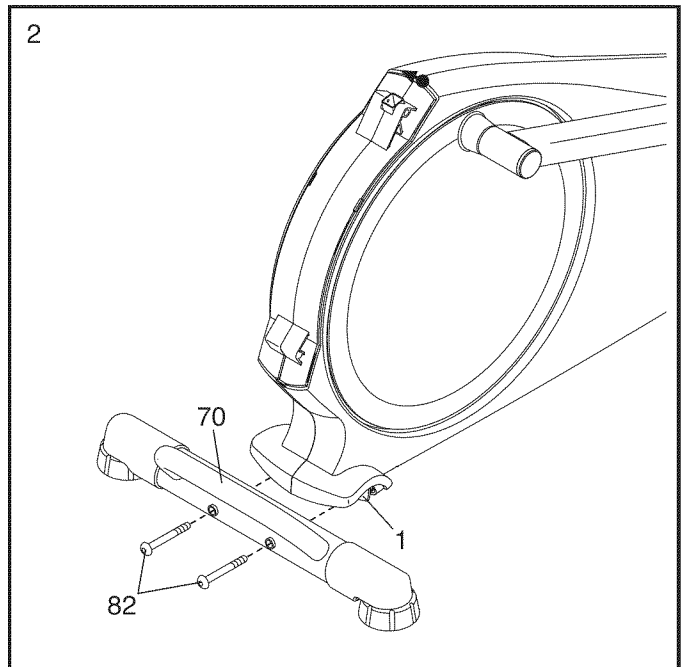
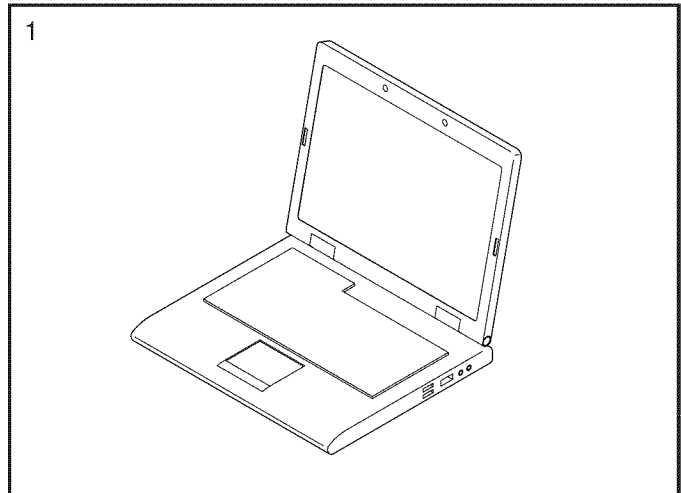

3. Orient the Front Stabilizer (73) so that the sticker is facing away from the front of the Frame (1).

While a second person lifts the front of the Frame (1), attach the Front Stabilizer (73) to the Frame with two M10 x 85mm Screws (82).

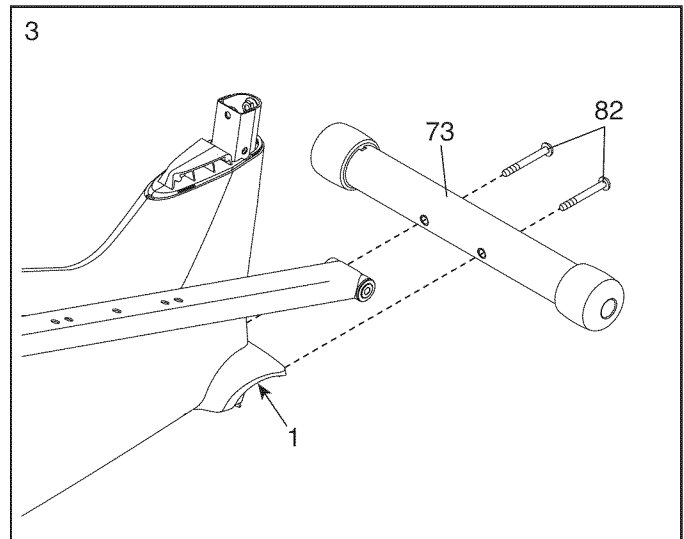

4. Orient the Upright (2) and the Top Shield Cover (37) as shown. Slide the Top Shield Cover upward onto the Upright.

Have a second person hold the Upright (2) near the Frame (1).

See the inset drawing. Locate the wire tie in the Upright (2). Tie the lower end of the wire tie to the Main Wire (42). Next, pull the upper end of the wire tie upward out of the top of the Upright.

Tip: To prevent the Main Wire (42) from falling into the Upright (2), secure the Main Wire with a wire tie.

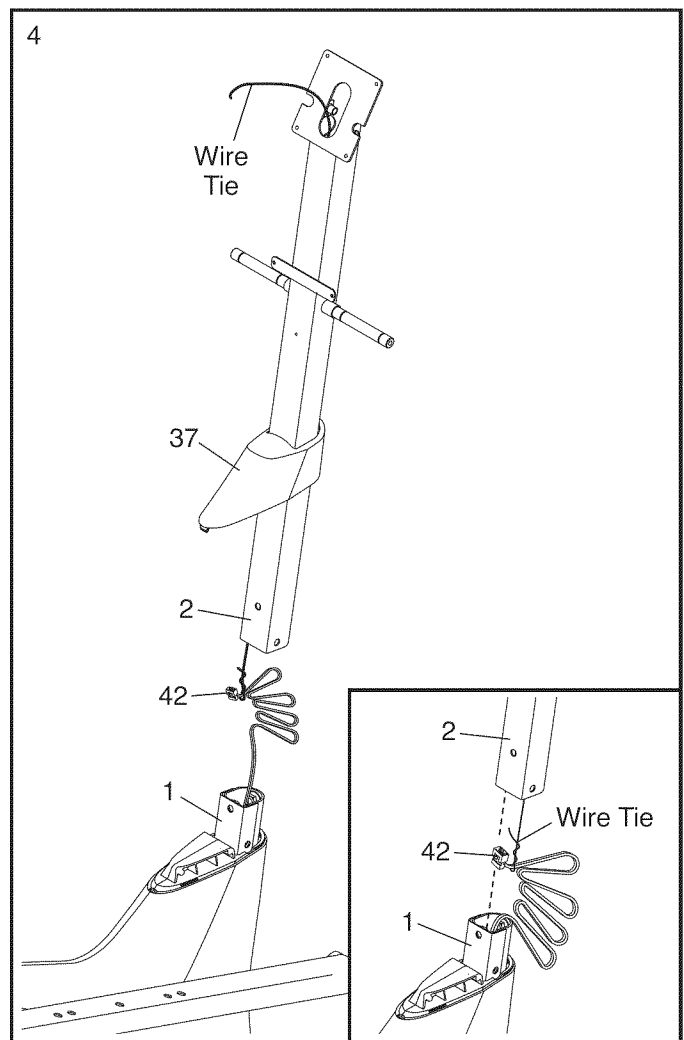

5. Slide the Upright (2) onto the Frame (1). **Tip: Have a second person hold the Top Shield Cover (37) out of the way.**

Tip: Avoid pinching the Main Wire (42). Attach the Upright (2) with four M10 x 20mm Screws (79) and four M10 Split Washers (78); **start all the Screws, and then tighten them.**

Then, slide the Top Shield Cover (37) downward and press it into the Frame (1).

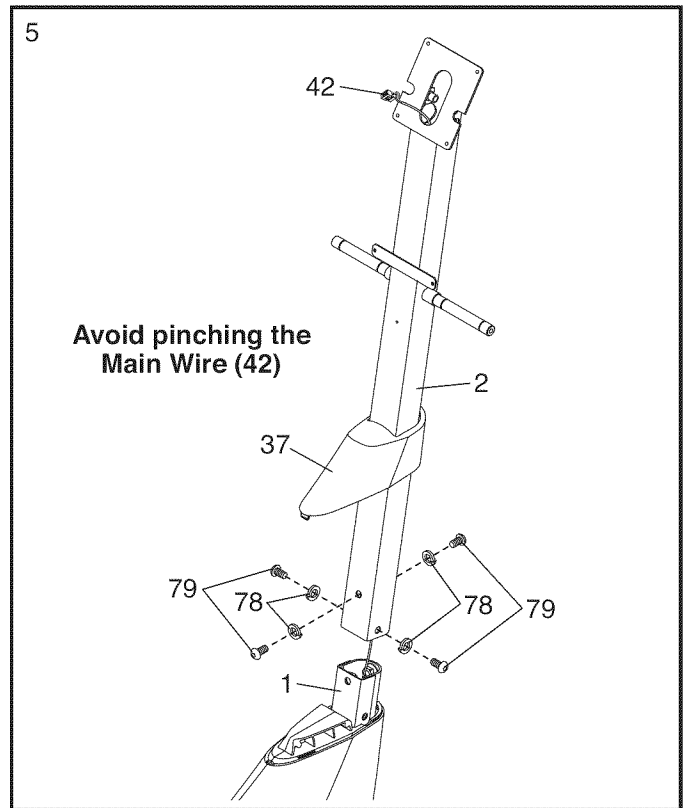

6. **See the upper drawing.** To avoid pinching or damaging the Pulse Wires (28) while you assemble the Handlebar (39), perform the following actions:

Insert the end of the left Pulse Wire (28) into the left side of the Handlebar (39).

Then, insert the end of the right Pulse Wire (28) into the right side of the Handlebar (39).

See the lower drawing. Have a second person hold the Handlebar (39) in place around the Upright (2).

Tip: Avoid pinching the wires. Attach the Handlebar (39) to the Upright (2) with three M10 x 20mm Screws (79); **start all the Screws, and then tighten them.**

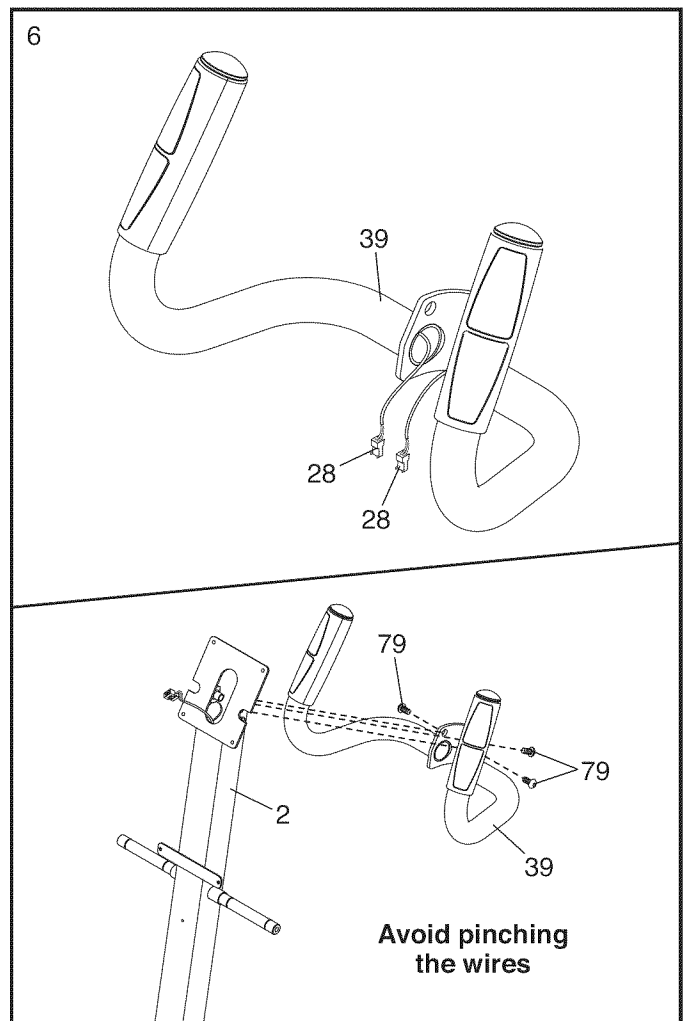

7. The Console (4) can use four D batteries (not included); alkaline batteries are recommended. Do not use old and new batteries together or alkaline, standard, and rechargeable batteries together. **IMPORTANT: If the Console has been exposed to cold temperatures, allow it to warm to room temperature before you insert batteries. Otherwise, you may damage the console displays or other electronic components.** Remove the screws and the battery covers, and insert batteries into the battery compartments. **Make sure to orient the batteries as shown by the diagram inside the battery compartment.** Then, reattach the battery covers.

To purchase an optional power adapter, call the telephone number on the cover of this manual. To avoid damaging the console, use only a manufacturer-supplied regulated power adapter. Plug one end of the power adapter into the receptacle on the frame of the elliptical; plug the other end into an outlet installed in accordance with all local codes and ordinances.

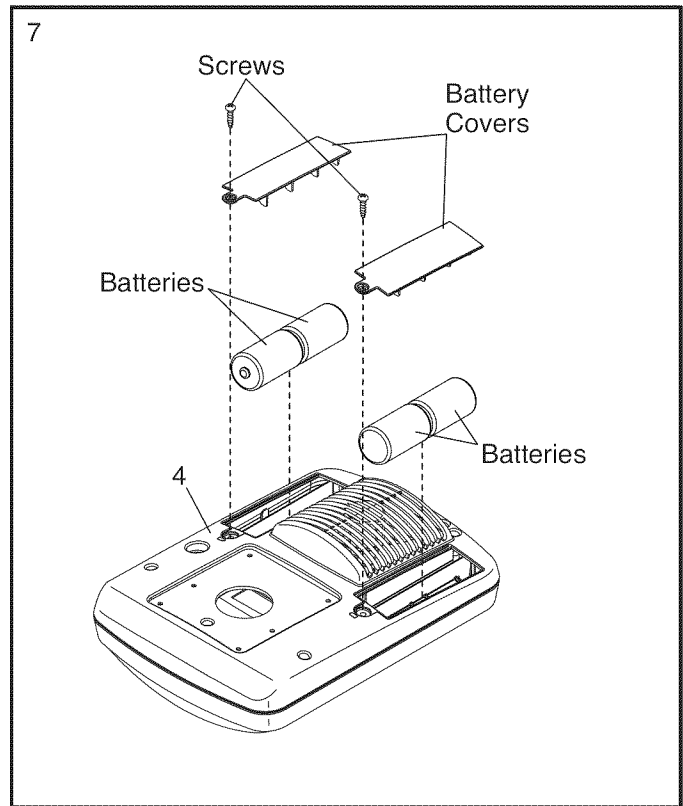

8. Untie and discard the wire tie attached to the Main Wire (42).

Locate the Pulse Wires (28) inside the left and right sides of the Handlebar (39) and pull them upward out of the Upright (2).

While a second person holds the Console (4) near the Upright (2), connect the wires on the Console to the Main Wire (42) and to the Pulse Wires (28).

Insert the excess wires into the Upright (2).

Tip: Avoid pinching the wires. Attach the Console (4) to the Upright (2) with four M4 x 16mm Screws (92); **start all the Screws, and then tighten them.**

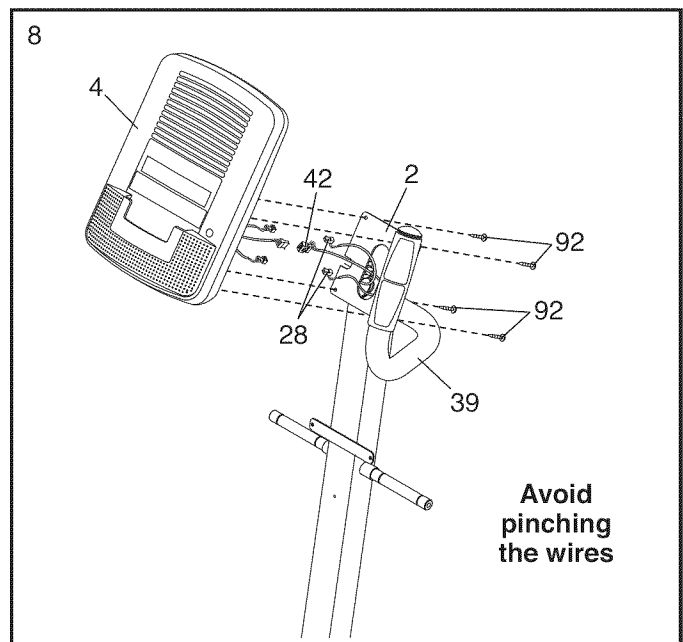

9. Attach the Console Cover (32) to the back of the Console (4) with two M4 x 48mm Screws (89).

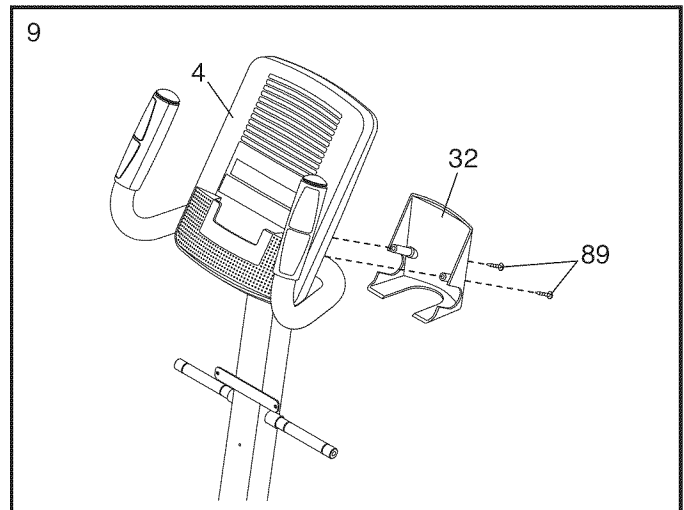

10. Identify the Left and Right Upper Body Arms (8, 9), and orient them as shown.

Orient the Left Upper Body Arm (8) and an Upper Body Leg (6) as shown. **Make sure that the hexagonal holes are in the indicated location.**

Insert the Left Upper Body Arm (8) into the Upper Body Leg (6).

Attach the Left Upper Body Arm (8) with two M8 x 45mm Bolts (76) and two M8 Jam Nuts (77). **Make sure that the Jam Nuts are in the hexagonal holes. Do not tighten the Bolts yet.**

Attach the Right Upper Body Arm (9) to the other Upper Body Leg (6) in the same way.

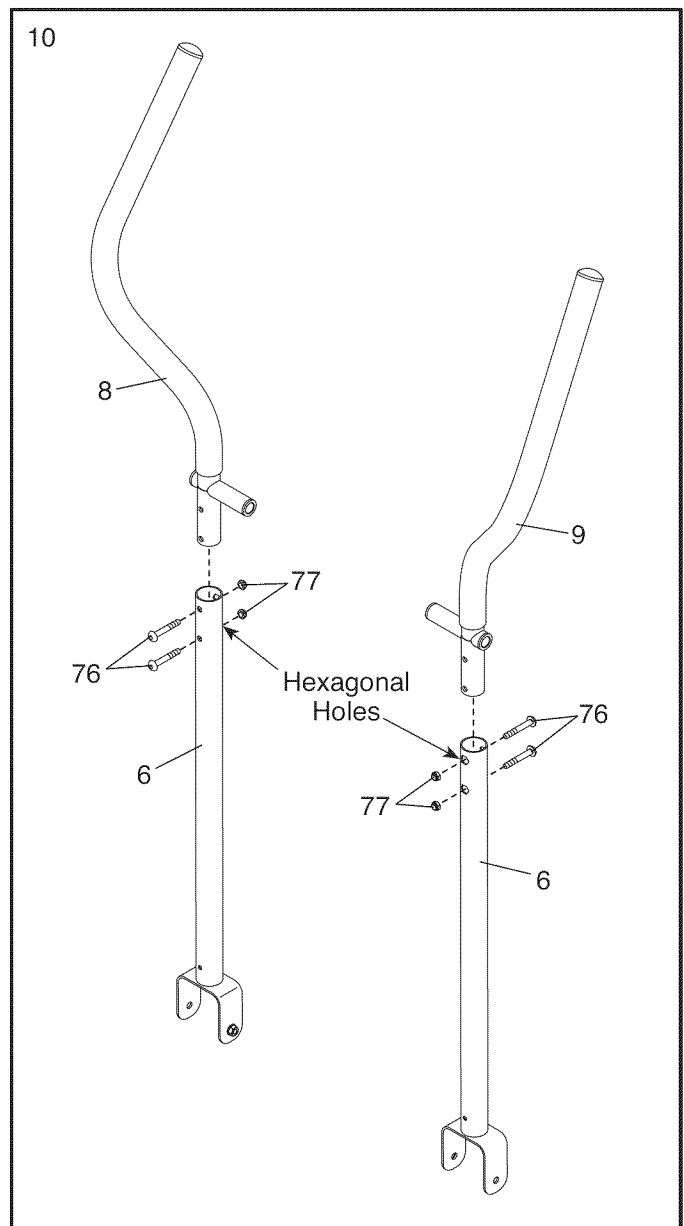

11. Using a plastic bag to keep your fingers clean, apply a generous amount of the included grease to the axles on the Upright (2).

Orient the Left and Right Upper Body Arms (8, 9) as shown, and slide them onto the left and right sides of the Upright (2).

Attach each Upper Body Arm (8, 9) with an M8 x 20mm Screw (80) and an M8 Washer (33).

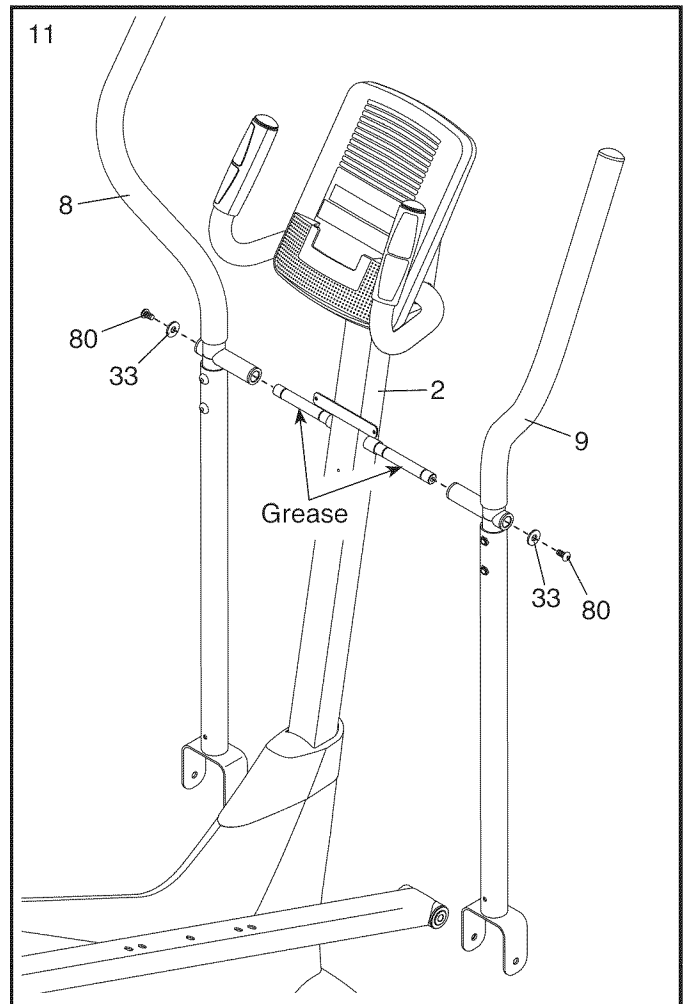

12. Apply a small amount of grease to a Shoulder Bolt (31).

While a second person holds the front end of the Right Pedal Arm (49) inside the bracket on the right Upper Body Leg (6), insert the Shoulder Bolt (31) through the right Upper Body Leg and the Right Pedal Arm.

Tighten the Shoulder Bolt (31) into the welded nut on the right Upper Body Leg (6).

Repeat this step to attach the Left Pedal Arm (not shown) to the left Upper Body Leg (6).

Then, tighten the M8 x 45mm Bolts (76).

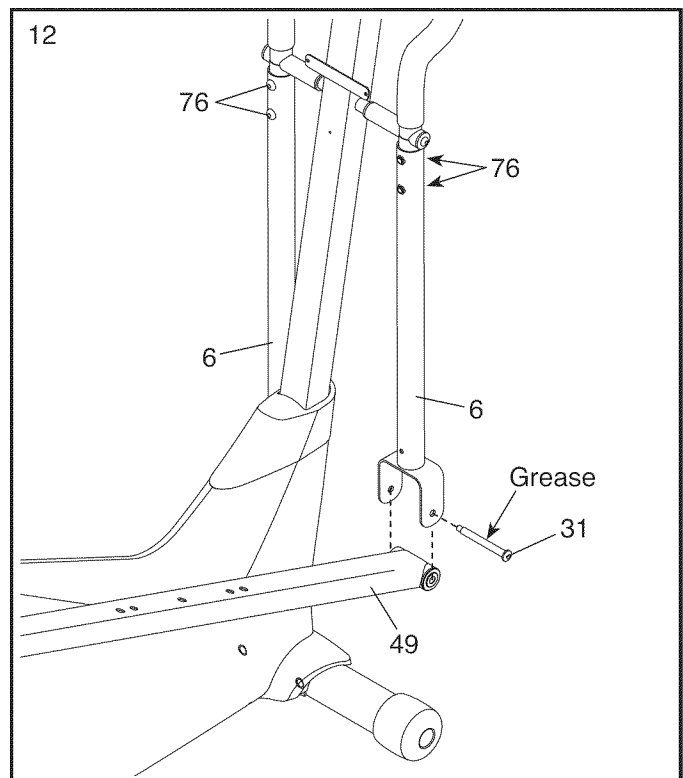

13. **See the inset drawing.** Identify a Pivot Cover A (19), which has hooks, and a Pivot Cover B (22), which has tabs.

Press the Pivot Cover A (19) and the Pivot Cover B (22) together around the Right Upper Body Arm (9).

Repeat this step on the other side of the elliptical.

Tip: Make sure that the Pivot Covers (19, 22) are positioned as shown.

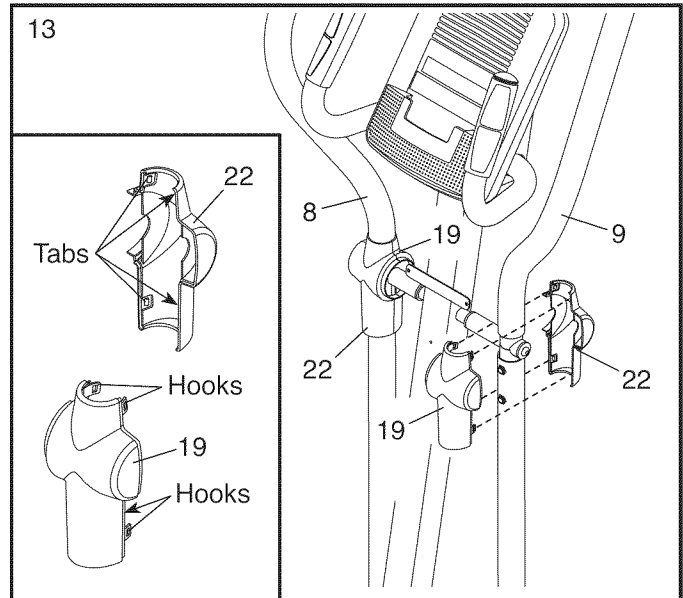

14. Attach the Rear Upright Cover (3) to the Upright (2) with three M4 x 16mm Screws (92).

Next, orient the Front Upright Cover (16) so that the indicated arrow is pointing upward.

Press the Front Upright Cover (16) into the Rear Upright Cover (3).

Then, press the Water Bottle Holder (5) into the Rear Upright Cover (3).

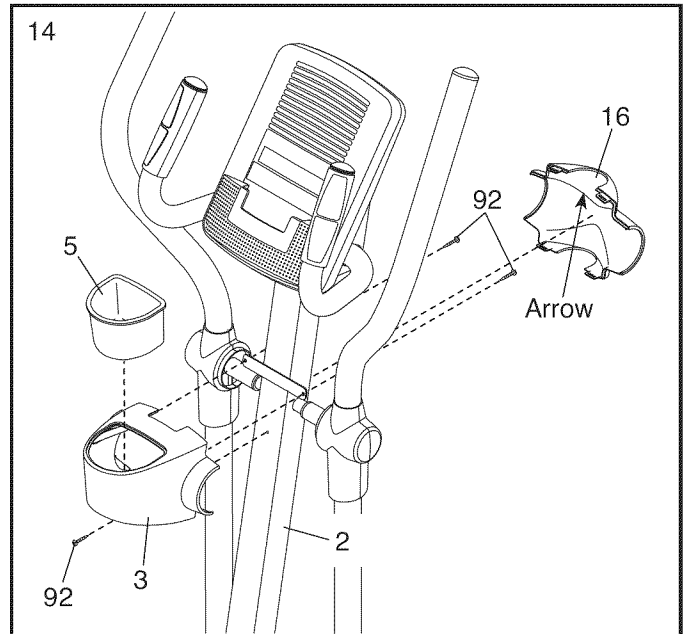

15. Press a Front Leg Cover (20) and a Rear Leg Cover (21) together around the right Upper Body Leg (6).

Repeat this step on the other side of the elliptical.

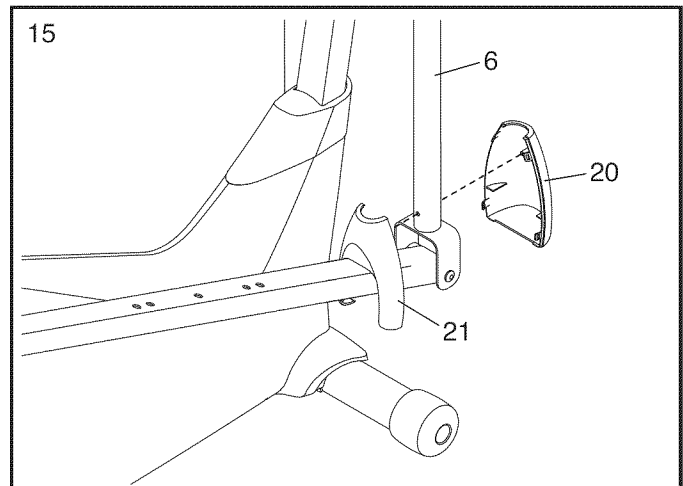

16. Identify the Right Pedal (13), and orient it as shown.

Attach the Right Pedal (13) to the Right Pedal Arm (49) with three M10 x 48mm Screws (75) and three M10 Split Washers (78); **start all the Screws, and then tighten them. Make sure to use the center hole and the two outer holes to attach the Right Pedal.**

Attach the Left Pedal (not shown) to the Left Pedal Arm (not shown) in the same way.

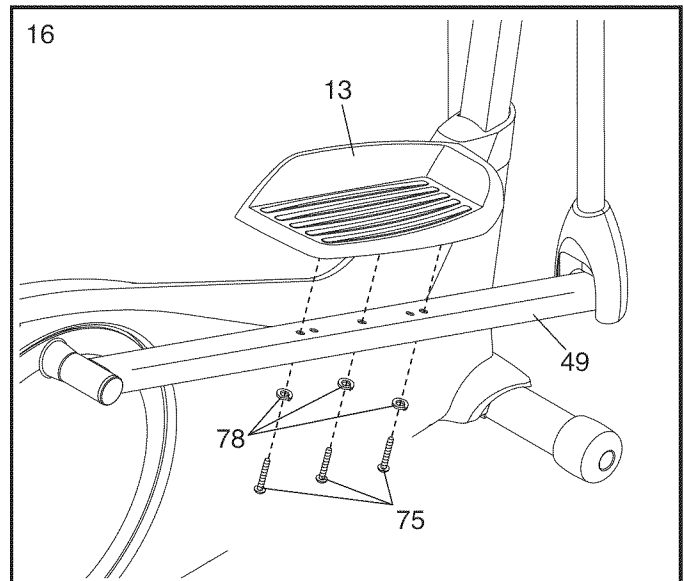

17. Press the Rear Shield Cover (59) onto the Left and Right Shields (44, 45).

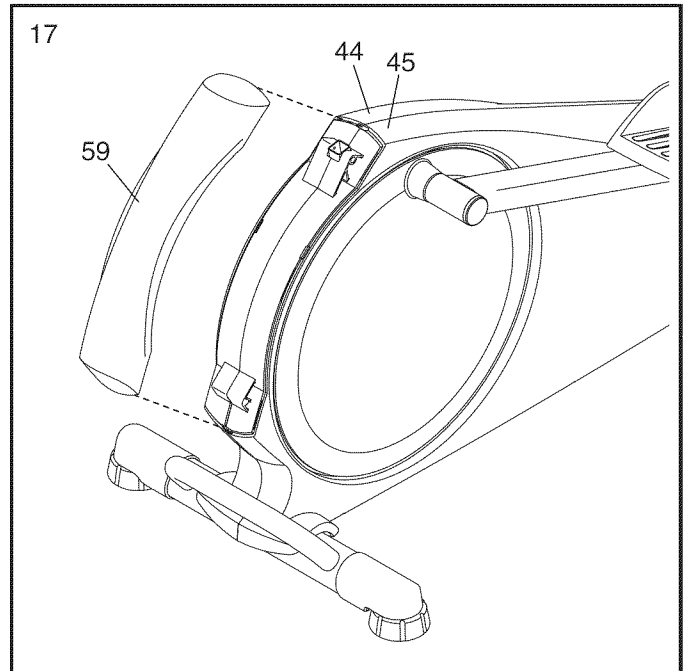

18. **Make sure that all parts are properly tightened before you use the elliptical.** Extra parts may be included. Place a mat beneath the elliptical to protect the floor.

HOW TO USE THE ELLIPTICAL

HOW TO MOVE THE ELLIPTICAL

Due to the size and weight of the elliptical, moving it requires two persons. Stand in front of the elliptical, hold the upright, and place one foot against one of the front wheels. Pull on the upright and have a second person lift the handle until the elliptical will roll on the wheels. Carefully move the elliptical to the desired location, and then lower it to the floor.

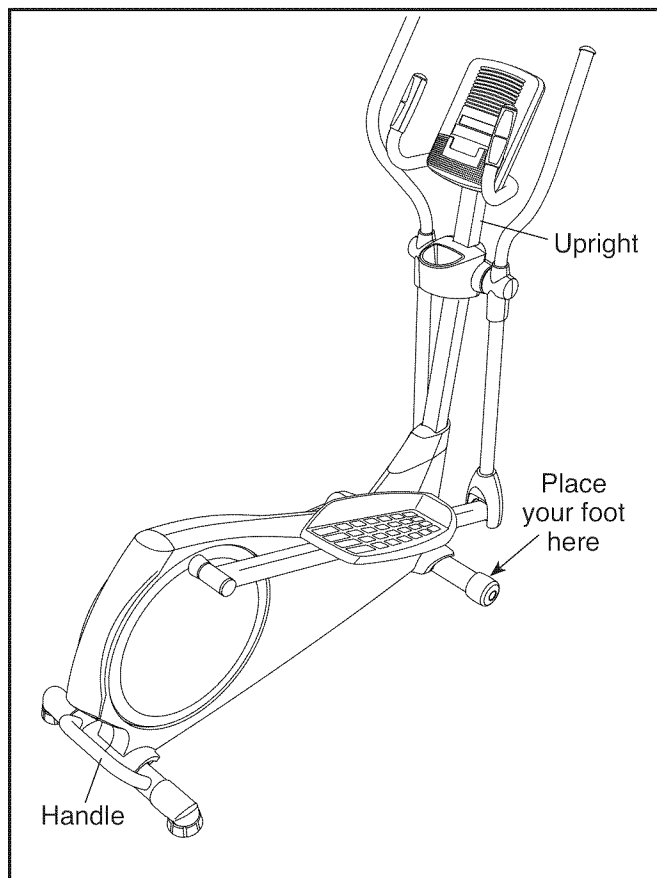

HOW TO EXERCISE ON THE ELLIPTICAL

To mount the elliptical, hold the handlebars or the upper body arms and step onto the pedal that is in the lowest position. Then, step onto the other pedal.

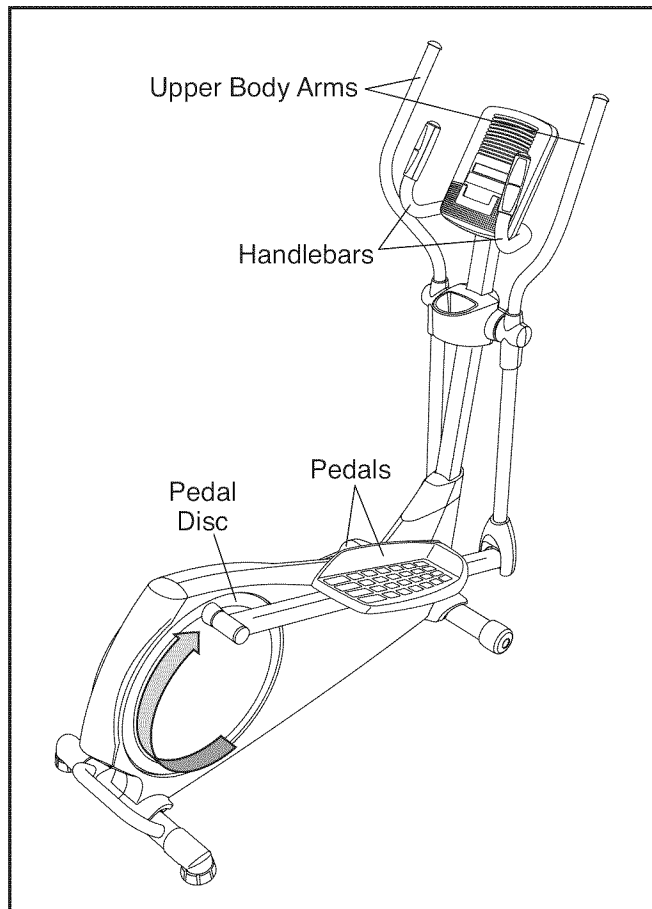

HOW TO LEVEL THE ELLIPTICAL

If the elliptical rocks slightly on your floor during use, turn one or both of the leveling feet beneath the rear stabilizer until the rocking motion is eliminated.

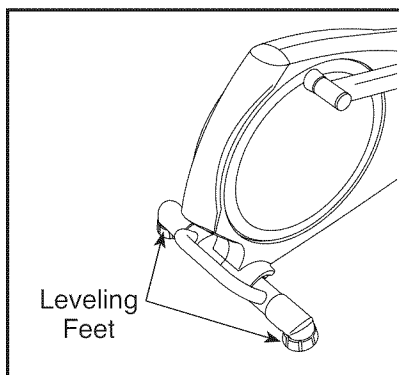

Push the pedals until they begin to move with a continuous motion. **Note: The pedal discs can turn in either direction. It is recommended that you move the pedal discs in the direction shown by the arrow; however, for variety, you can turn the pedal discs in the opposite direction.**

To dismount the elliptical, wait until the pedals come to a complete stop. **Note: The elliptical does not have a free wheel; the pedals will continue to move until the flywheel stops.** When the pedals are stationary, step off the highest pedal first. Then, step off the lowest pedal.

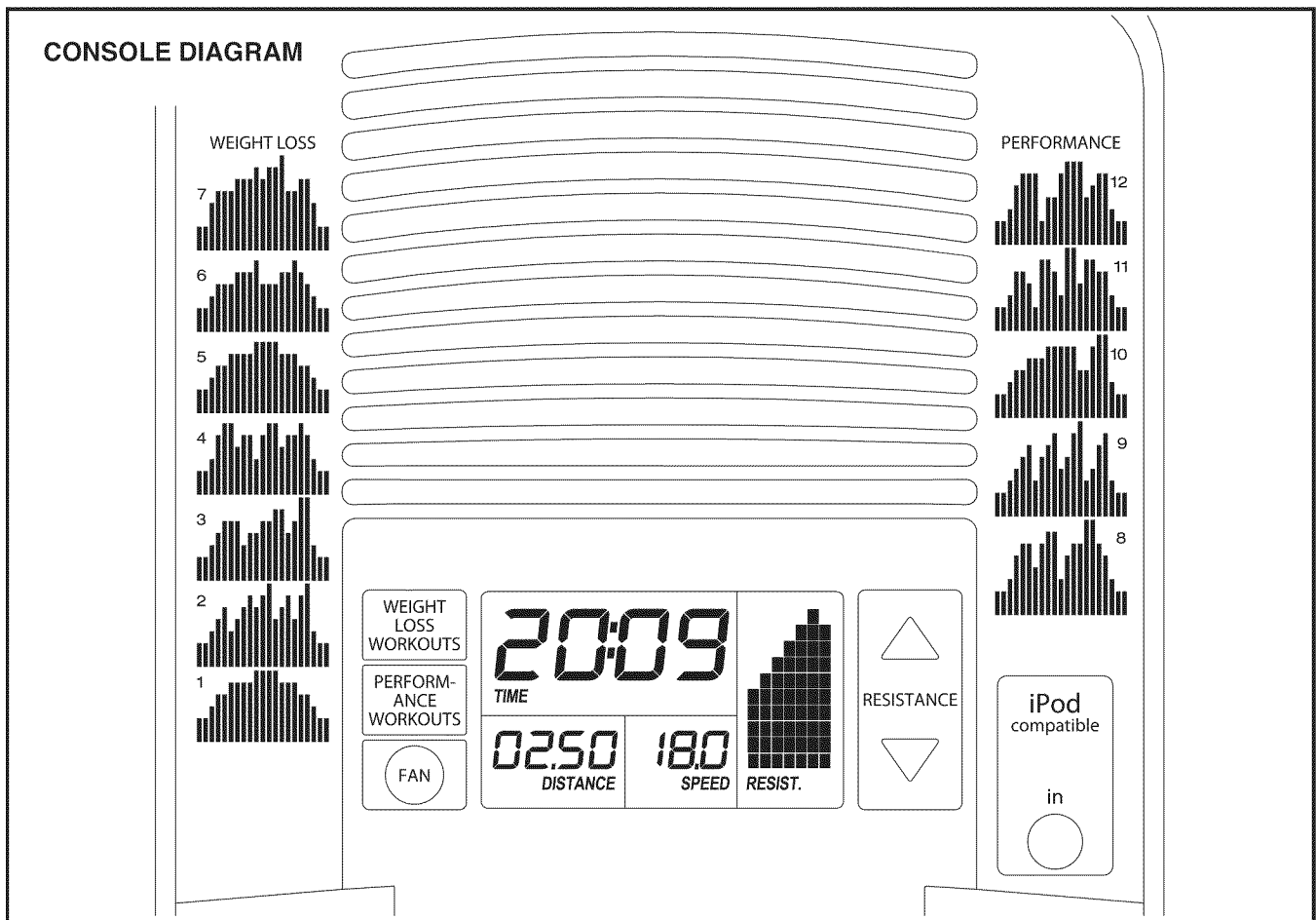

FEATURES OF THE CONSOLE

The advanced console offers an array of features designed to make your workouts more effective and enjoyable.

When you use the manual mode of the console, you can change the resistance of the pedals with the touch of a button. As you exercise, the console will provide continuous exercise feedback. You can even measure your heart rate using the handgrip heart rate monitor.

The console offers twelve preset workouts—seven weight loss workouts and five performance workouts. Each preset workout automatically changes the resistance of the pedals as it guides you through an effective workout.

You can even connect your MP3 player or CD player to the console sound system and listen to your favorite music or audio books while you exercise.

To use the manual mode, see page 16. **To use a preset workout**, see page 17. **To use the sound system**, see page 17.

Note: Before using the console, make sure that batteries are installed (see assembly step 7 on page 9). If there is a sheet of plastic on the display, remove the plastic.

HOW TO USE THE MANUAL MODE

1. Turn on the console.

Press any button or begin pedaling to turn on the console.

When you turn on the console, the display will light. A tone will sound and the console will be ready for use.

2. Select the manual mode.

When you turn on the console, the manual mode will be selected.

If you have selected a workout, reselect the manual mode by pressing the Weight Loss Workouts or the Performance Workouts button repeatedly until zeros appear in the displays.

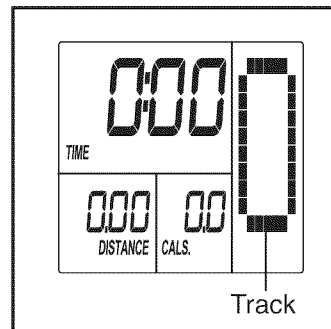

3. Begin pedaling and change the resistance of the pedals as desired.

As you pedal, change the resistance of the pedals by pressing the Resistance increase and decrease buttons.

Note: After you press the buttons, it will take a moment for the pedals to reach the selected resistance level.

4. Follow your progress with the displays.

The upper display—This display will show the elapsed time and the resistance level of the pedals each time the resistance level changes.

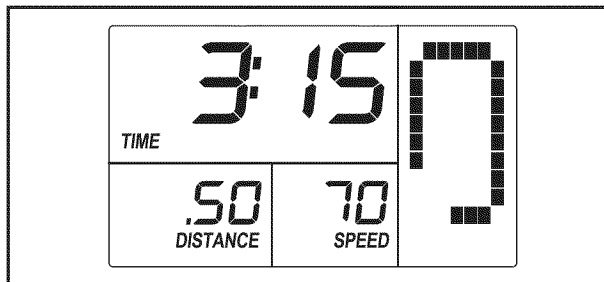

Note: During a workout, the display will show the time remaining in the workout.

The lower left display—This display will show the distance (total number of revolutions) that you have pedaled.

The lower right display—This display will show your pedaling speed in revolutions per minute (rpm) and the approximate number of calories you have burned.

The lower right display will also show your heart rate when you use the handgrip heart rate monitor (see step 5).

The right display—This display will show a track that represents 1/4 mile (400 m). As you exercise, indicators will appear in succession around the track until the entire track appears. The track will then disappear and the indicators will again begin to appear in succession.

5. Measure your heart rate if desired.

If there are sheets of plastic on the metal contacts on the handgrip heart rate monitor, remove the plastic. In addition, make sure that your hands are clean. To

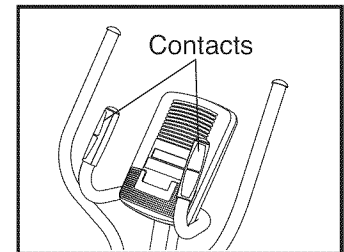

measure your heart rate, hold the handgrip heart rate monitor with your palms resting against the contacts. **Avoid moving your hands or gripping the contacts tightly.**

When your pulse is detected, a heart-shaped symbol will flash in the display and then your heart rate will be shown. For the most accurate heart rate reading, hold the contacts for at least 15 seconds.

If your heart rate is not shown, make sure that your hands are positioned as described. Be careful not to move your hands excessively or to squeeze the contacts tightly. For optimal performance, clean the contacts using a soft cloth; **never use alcohol, abrasives, or chemicals to clean the contacts.**

6. Turn on the fan if desired.

The fan has high and low speed settings. Press the Fan button repeatedly to select a fan speed or to turn off the fan.

Note: If the pedals do not move for about 30 seconds, the fan will turn off automatically.

7. When you are finished exercising, the console will turn off automatically.

If the pedals do not move for several seconds, a series of tones will sound, the console will pause, and the time will flash in the display.

If the pedals do not move for several minutes, the console will turn off and the display will be reset.

HOW TO USE A PRESET WORKOUT

1. Turn on the console.

See step 1 on page 16.

2. Select a preset workout.

To select a preset workout, press the Weight Loss Workouts or the Performance Workouts button repeatedly until the name of the desired workout appears in the upper display.

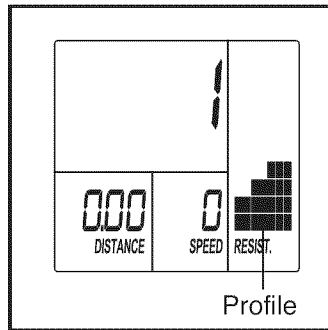

When you select a preset workout, the duration of the workout will appear in the upper display and a profile of the resistance levels of the workout will scroll across the center display.

Note: Complete profiles of the preset workouts are printed on the sides of the console.

3. Begin pedaling to start the workout.

Each workout is divided into 30 one-minute segments. One resistance level is programmed for each segment. Note: The same resistance level may be programmed for consecutive segments.

During the workout, the workout profile will show your progress (see the drawing above). The flashing segment of the profile represents the current segment of the workout. The height of the flashing segment indicates the resistance level for the current segment.

At the end of each segment of the workout, a series of tones will sound and the next segment of the profile will begin to flash. If a different resistance level is programmed for the next segment, the resistance level will flash in the display for a

few seconds to alert you. The resistance of the pedals will then change.

If the resistance level for the current segment is too high or too low, you can manually override the setting by pressing the Resistance buttons. However, when the current segment ends, the pedals will automatically adjust to the resistance level for the next segment.

If you stop pedaling for several seconds, a series of tones will sound and the workout will pause.

To restart the workout, simply resume pedaling. The workout will continue until the last segment of the profile flashes and the last segment of the workout ends.

Note: If you continue to pedal after the workout is completed, the display will continue to show exercise feedback; however, the display will not show the elapsed time until you select the manual mode or a new workout.

4. Follow your progress with the display.

See step 4 on page 16.

5. Measure your heart rate if desired.

See step 5 on page 16.

6. Turn on the fan if desired.

See step 6 on page 16.

7. When you are finished exercising, the console will turn off automatically.

See step 7 on this page.

HOW TO USE THE SOUND SYSTEM

To play music or audio books through the console sound system while you exercise, plug a 3.5 mm male to 3.5 mm male audio cable (not included) into the jack on the console and into a jack on your MP3 player, CD player, or other personal audio player; **make sure that the audio cable is fully plugged in. Note: To purchase an audio cable, see your local electronics store.**

Next, press the play button on your personal audio player. Adjust the volume level using the volume increase and decrease buttons on the console or the volume control on your personal audio player.

MAINTENANCE AND TROUBLESHOOTING

MAINTENANCE

Regular maintenance is important for optimal performance and to reduce wear. Inspect and properly tighten all parts each time the elliptical is used. Replace any worn parts immediately.

To clean the elliptical, use a damp cloth and a small amount of mild soap. **IMPORTANT: To avoid damage to the console, keep liquids away from the console and keep the console out of direct sunlight.**

CONSOLE TROUBLESHOOTING

Most console problems are the result of low batteries. See assembly step 7 on page 9 for replacement instructions.

If the handgrip heart rate monitor does not function properly, see step 5 on page 16.

HOW TO ADJUST THE DRIVE BELT

If you can feel the pedals slip while you are pedaling, even when the resistance is adjusted to the highest level, the drive belt may need to be adjusted.

To adjust the drive belt, you must remove the left pedal, the top shield cover, the rear shield cover, and the left shield.

First, **see step 16 on page 13** and remove the left pedal.

Next, **see step 17 on page 13** and remove the rear shield cover.

Then, **see step 5 on page 8** and release the top shield cover from the shields. Slide the top shield cover upward.

See the upper drawing at the right. Remove the M4 x 16mm Screws (92) from the Left Shield (44) and then gently move the Left Shield outward over the Left Pedal Arm (14).

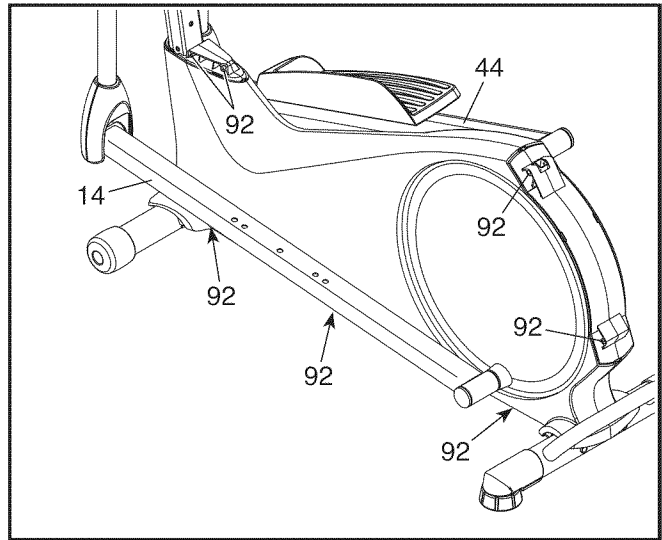

Next, loosen the Pivot Screw (88). Then, tighten the Drive Belt Adjustment Screw (72) until the Drive Belt (46) is tight.

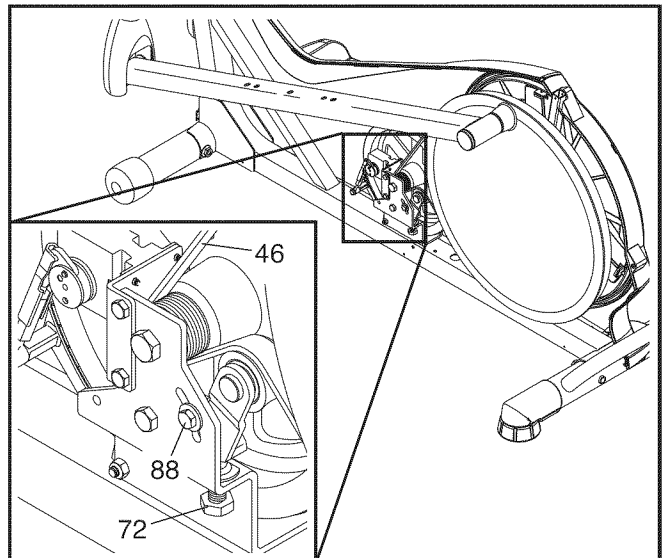

When the Drive Belt (46) is tight, tighten the Pivot Screw (88).

Then, reattach the left shield, the rear shield cover, the top shield cover, and the left pedal.

HOW TO ADJUST THE REED SWITCH

If the console does not display correct feedback, the reed switch should be adjusted.

To adjust the reed switch, you must remove the right disc cover and the right pedal disc.

Using a standard screwdriver, remove the right Disc Cover (18).

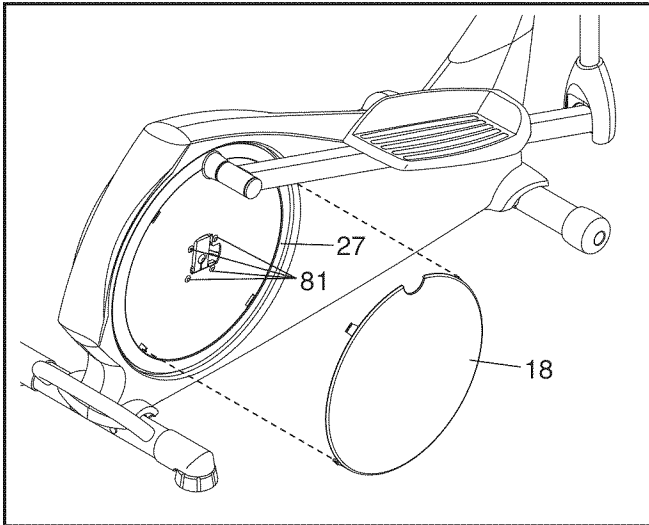

Then, remove the M8 x 12mm Screws (81) from the Right Pedal Disc (27), and gently rotate the Right Pedal Disc out of the way.

Locate the Reed Switch (58). Loosen, but do not remove, the M4 x 16mm Screw (92).

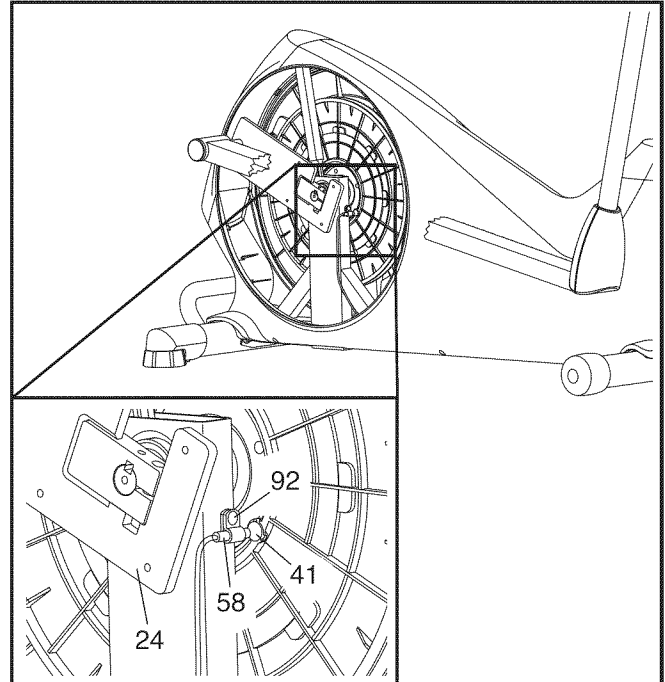

Next, rotate the Crank Assembly (24) until a Magnet (41) is aligned with the Reed Switch (58). Slide the Reed Switch slightly toward or away from the Magnet. Then, retighten the M4 x 16mm Screw (92).

Rotate the Crank Assembly (24) for a moment. Repeat these actions until the console displays correct feedback.

When the reed switch is correctly adjusted, reattach the right pedal disc and the right disc cover.

EXERCISE GUIDELINES

⚠️ WARNING: Before beginning this or any exercise program, consult your physician. This is especially important for persons over age 35 or persons with pre-existing health problems.

The heart rate monitor is not a medical device. Various factors may affect the accuracy of heart rate readings. The heart rate monitor is intended only as an exercise aid in determining heart rate trends in general.

These guidelines will help you to plan your exercise program. For detailed exercise information, obtain a reputable book or consult your physician. Remember, proper nutrition and adequate rest are essential for successful results.

EXERCISE INTENSITY

Whether your goal is to burn fat or to strengthen your cardiovascular system, exercising at the proper intensity is the key to achieving results. You can use your heart rate as a guide to find the proper intensity level. The chart below shows recommended heart rates for fat burning and aerobic exercise.

165	155	145	140	130	125	115	♥
145	138	130	125	118	110	103	♥
125	120	115	110	105	95	90	♥
<hr/>							
20	30	40	50	60	70	80	

To find the proper intensity level, find your age at the bottom of the chart (ages are rounded off to the nearest ten years). The three numbers listed above your age define your “training zone.” The lowest number is the heart rate for fat burning, the middle number is the heart rate for maximum fat burning, and the highest number is the heart rate for aerobic exercise.

Burning Fat—To burn fat effectively, you must exercise at a low intensity level for a sustained period of time. During the first few minutes of exercise, your body uses carbohydrate calories for energy. Only after the first few minutes of exercise does your body begin to use stored fat calories for energy. If your goal is to burn fat, adjust the intensity of your exercise until your heart rate is near the lowest number in your training zone. For maximum fat burning, exercise with your heart rate near the middle number in your training zone.

Aerobic Exercise—If your goal is to strengthen your cardiovascular system, you must perform aerobic exercise, which is activity that requires large amounts of oxygen for prolonged periods of time. For aerobic exercise, adjust the intensity of your exercise until your heart rate is near the highest number in your training zone.

WORKOUT GUIDELINES

Warming Up—Start with 5 to 10 minutes of stretching and light exercise. A warm-up increases your body temperature, heart rate, and circulation in preparation for exercise.

Training Zone Exercise—Exercise for 20 to 30 minutes with your heart rate in your training zone. (During the first few weeks of your exercise program, do not keep your heart rate in your training zone for longer than 20 minutes.) Breathe regularly and deeply as you exercise; never hold your breath.

Cooling Down—Finish with 5 to 10 minutes of stretching. Stretching increases the flexibility of your muscles and helps to prevent post-exercise problems.

EXERCISE FREQUENCY

To maintain or improve your condition, complete three workouts each week, with at least one day of rest between workouts. After a few months of regular exercise, you may complete up to five workouts each week, if desired. Remember, the key to success is to make exercise a regular and enjoyable part of your everyday life.

PART LIST

Model No. 23943.5 R0915A

Key No.	Qty.	Description	Key No.	Qty.	Description
1	1	Frame	52	1	Idler
2	1	Upright	53	1	C-magnet
3	1	Rear Upright Cover	54	1	Resistance Motor
4	1	Console	55	1	Motor Bracket
5	1	Accessory Tray	56	1	Adjustment Arm
6	2	Upper Body Leg	57	1	Clamp
7	1	Resistance Wheel	58	1	Reed Switch/Wire
8	1	Left Upper Body Arm	59	1	Rear Shield Cover
9	1	Right Upper Body Arm	60	1	Key
10	2	Foam Grip	61	1	M8 Locknut
11	2	Upper Cap	62	1	M6 x 16mm Screw
12	1	Left Pedal	63	2	Shoulder Screw
13	1	Right Pedal	64	1	Flywheel Axle
14	1	Left Pedal Arm	65	1	C-magnet Bolt
15	2	Pedal Bracket	66	1	Idler Bolt
16	1	Front Upright Cover	67	1	Key Screw
17	4	Pivot Bushing	68	1	Crank Arm Screw
18	2	Disc Cover	69	4	Resistance Motor Screw
19	2	Pivot Cover A	70	1	Rear Stabilizer
20	2	Front Leg Cover	71	2	Motor Bracket Screw
21	2	Rear Leg Cover	72	1	Drive Belt Adjustment Screw
22	2	Pivot Cover B	73	1	Front Stabilizer
23	4	Bushing Set	74	1	M6 Locknut
24	1	Crank	75	6	M10 x 48mm Screw
25	1	Right Crank Arm	76	4	M8 x 45mm Bolt
26	1	Left Pedal Disc	77	6	M8 Jam Nut
27	1	Right Pedal Disc	78	10	M10 Split Washer
28	2	Pulse Wire	79	7	M10 x 20mm Screw
29	4	Bearing	80	2	M8 x 20mm Screw
30	2	Pedal Arm Cap	81	8	M8 x 12mm Screw
31	2	Shoulder Bolt	82	4	M10 x 85mm Screw
32	1	Console Cover	83	1	M5 x 7mm Screw
33	4	M8 Washer	84	10	#10 x 16mm Screw
34	1	Adjustment Block	85	2	M8 x 18mm Hex Screw
35	1	M5 Washer	86	1	Pulley
36	1	Small Snap Ring	87	1	M3.5 x 12mm Screw
37	1	Top Shield Cover	88	1	Pivot Screw
38	2	Crank Bearing	89	2	M4 x 48mm Screw
39	1	Handlebar	90	1	M4 x 16mm Ground Screw
40	2	Eddy Mech Spacer	91	2	Adjustment Nut
41	2	Magnet	92	21	M4 x 16mm Screw
42	1	Main Wire	93	2	Pulse Sensor/Wire
43	2	M6 Washer	94	1	Flywheel Bearing
44	1	Left Shield	95	4	M8 x 15mm Screw
45	1	Right Shield	96	1	Left Crank Arm
46	1	Drive Belt	97	1	Crank Arm Spacer
47	2	Leveling Foot	98	4	M8 x 10mm Screw
48	2	Stabilizer Cap	99	2	Snap Ring
49	1	Right Pedal Arm	*	—	User's Manual
50	2	Wheel	*	—	Assembly Tool
51	1	Flywheel	*	—	Grease Packet

Note: Specifications are subject to change without notice. For information about ordering replacement parts, see the back cover of this manual. **If a part is missing, call 1-888-533-1333.** *These parts are not illustrated.

EXPLODED DRAWING A

Model No. 23943.5 R0915A

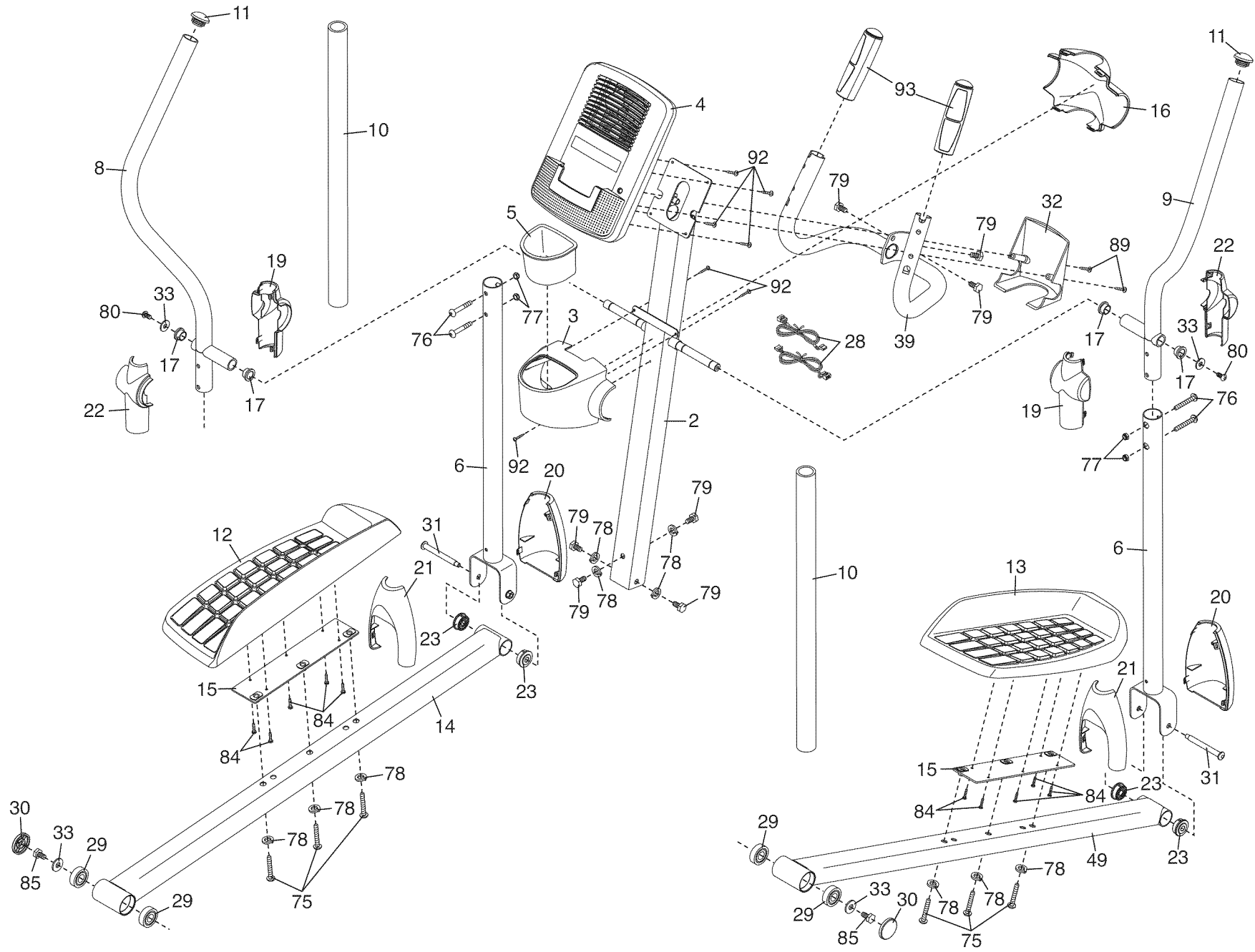

EXPLODED DRAWING B

Model No. 23943.5 R0915A

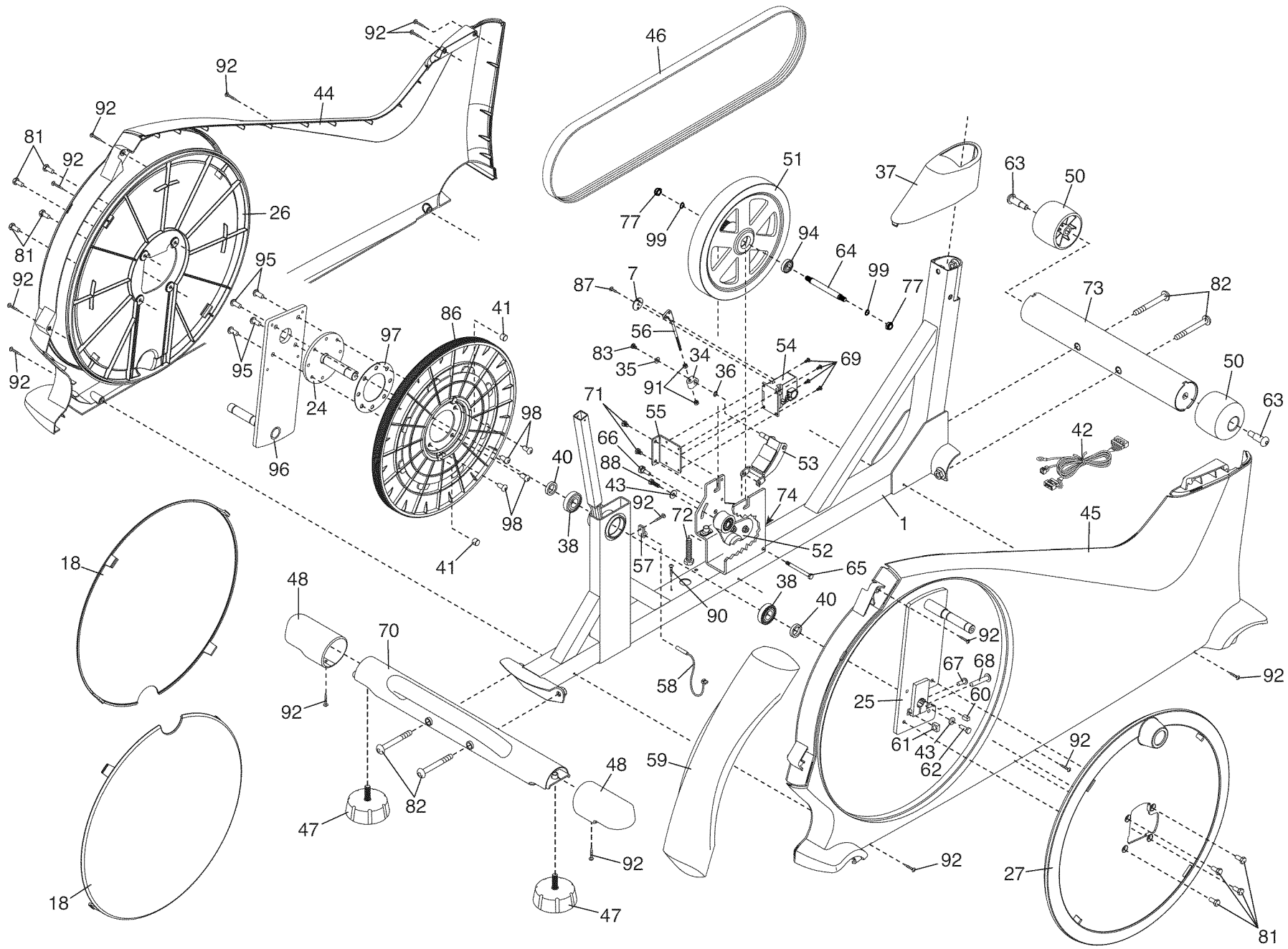

23

Get it fixed, at your home or ours!

Your Home

For repair—**in your home**—of **all** major brand appliances, lawn and garden equipment, or heating and cooling systems, **no matter who made it, no matter who sold it!**

For the replacement parts, accessories, and user's manuals that you need to do-it-yourself.

For Sears professional installation of home appliances and items like garage door openers and water heaters.

1-800-4-MY-HOME® (1-800-469-4663)

Call anytime, day or night (U.S.A. and Canada)

www.sears.com

www.sears.ca

Our Home

For repair of carry-in items like vacuums, lawn equipment, and electronics, call or go on-line for the location of your nearest **Sears Parts & Repair Center.**

1-800-488-1222 Call anytime, day or night (U.S.A. only)

www.sears.com

To purchase a protection agreement (U.S.A.) or maintenance agreement (Canada) on a product serviced by Sears:

1-800-827-6655 (U.S.A.)

1-800-361-6665 (Canada)

Para pedir servicio de reparación a domicilio, y para ordenar piezas:

1-888-SU-HOGAR® (1-888-784-6427)



® Registered Trademark / ™ Trademark / ™ Service Mark of Sears Brands, LLC
® Marca Registrada / ™ Marca de Fábrica / ™ Marca de Servicio de Sears Brands, LLC

90 DAY FULL WARRANTY

If this Sears Elliptical Exerciser fails due to a defect in material or workmanship within 90 days of the date of purchase, call 1-800-4-MY-HOME® (1-800-469-4663) to arrange for free repair (or replacement if repair proves impossible). The frame is warranted for 5 years.

This warranty does not apply when the Elliptical Exerciser is used commercially or for rental purposes.

This warranty gives you specific legal rights, and you may also have other rights which vary from state to state.

Sears, Roebuck and Co., Hoffman Estates, IL 60179