

Use & Care Guide

Manual de Uso y Cuidado

Guide d'utilisation et d'entretien

English / Español / Français

Models/Modelos/Modèles: 253.12112*, 12402*, 12502*, 12512*, 12702*, 12810*,
12812*, 12912*, 21042*, 21242*, 21742*, 22040*,
22042*, 22442*, 22452*, 22742*, 12822*

Kenmore®

Freezer

Congelador
Congélateur

P/N A01062004 (1507)

Sears Brands Management Corporation

Hoffman Estates, IL 60179 U.S.A.

www.kenmore.com

www.sears.com

Sears Canada Inc.

Toronto, Ontario, Canada M5B 2C3

www.sears.ca



Record Model/ Serial Numbers

Please read and save these instructions

This Use & Care Guide provides specific operating instructions for your model. Use your unit only as instructed in this guide. These instructions are not meant to cover every possible condition and situation that may occur. Common sense and caution must be practiced when installing, operating, and maintaining any appliance.

Please record your model and serial numbers below for future reference. This information is found on the serial plate located inside the appliance compartment.

Model Number: 253. _____

or _____

Serial Number: _____

Purchase Date: _____

IMPORTANT

Use only soap and water to clean serial plate.

Table of Contents

Record Model/Serial Numbers.....	2
Important Safety Instructions.....	2
Warranty Information.....	4
Master Protection Agreements.....	5
First Steps.....	6
Energy-Saving Tips.....	8
Setting the Temperature Control.....	8
Optional Features.....	9
Care & Cleaning.....	10
Power/Freezer Failure.....	12
Before You Call.....	13

Safety Precautions

Do not attempt to install or operate your unit until you have read the safety precautions in this manual. Safety items throughout this manual are labeled with a Danger, Warning, or Caution based on the risk type.

Important Safety Instructions

Definitions

 This is the safety alert symbol. It is used to alert you to potential personal injury hazards. Obey all safety messages that follow this symbol to avoid possible injury or death.

DANGER

DANGER indicates an imminently hazardous situation which, if not avoided, will result in death or serious injury.

WARNING

WARNING indicates a potentially hazardous situation which, if not avoided, could result in death or serious injury.

CAUTION

CAUTION indicates a potentially hazardous situation which, if not avoided, may result in minor or moderate injury.

IMPORTANT

Indicates installation, operation, or maintenance information which is important but not hazard-related.

WARNING

Please read all safety instructions before using your new appliance.

For Your Safety

- Do not store or use gasoline or other flammable liquids in the vicinity of this or any other appliance. Read product labels for warnings regarding flammability and other hazards.
- Do not operate the unit in the presence of explosive fumes.
- Remove and discard any spacers used to secure the shelves during shipping. Small objects are a choke hazard to children.
- Remove all staples from the carton. Staples can cause severe cuts and also

Important Safety Instructions

destroy finishes if they come in contact with other appliances or furniture.

Child Safety

Destroy or recycle the carton, plastic bags, and any exterior wrapping material immediately after the unit is unpacked. Children should **never** use these items to play. Cartons covered with rugs, bedspreads, plastic sheets or stretch wrap may become airtight chambers and can quickly cause suffocation.

Proper Disposal of your Appliance

Risk of child entrapment

Child entrapment and suffocation are not problems of the past. Junked or abandoned appliances are still dangerous – even if they will sit for “just a few days.” If you are getting rid of your appliance, please follow the instructions below to help prevent accidents.

Before you throw away your old unit:

- Remove door.
- Leave shelves in place so children may not easily climb inside.
- Have refrigerant removed by a qualified service technician.

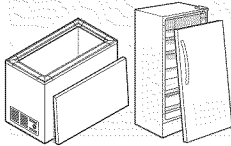

IMPORTANT

Your old unit may have a cooling system that used CFCs or HCFCs (chlorofluorocarbons or hydrochlorofluorocarbons). CFCs and HCFCs are believed to harm stratospheric ozone if released to the atmosphere. Other refrigerants may cause harm to the environment if released to the atmosphere. If you are throwing away your old unit, make sure the refrigerant is removed for proper disposal by a qualified technician. If you intentionally release refrigerant, you may be subject to fines and imprisonment under the provisions of environmental legislation.



WARNING

These guidelines must be followed to ensure that safety mechanisms in this unit will operate properly.

Electrical information

- The appliance must be plugged into its own dedicated 115 Volt, 60 Hz., AC only electric outlet. The power cord of the appliance is equipped with a three-prong grounding plug for your protection against electrical shock hazards. It must be plugged directly into a properly grounded three-prong receptacle. The receptacle must be installed in accordance with local codes and ordinances. Consult a qualified electrician. Do not use an extension cord or adapter plug.
- Immediately repair or replace any power cord that becomes frayed or damaged.
- Never unplug the appliance by pulling on the power cord. Always grip the plug firmly, and pull straight out from the receptacle to prevent damaging the power cord.
- Unplug the appliance before cleaning and before replacing a light bulb to avoid electrical shock.
- Performance may be affected if the voltage varies by 10% or more. Operating the unit with insufficient power can damage the motor. Such damage is not covered under the warranty.
- Do not plug the unit into an outlet controlled by a wall switch or pull cord to prevent the appliance from being turned off accidentally.
- Avoid connecting unit to a Ground Fault Circuit Interruptor (GFCI).

Grounding type wall receptacle

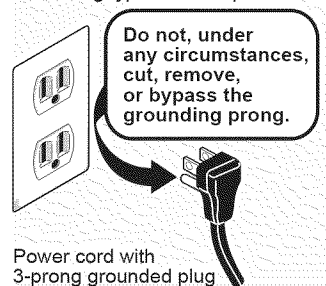

Power cord with 3-prong grounded plug

Warranty Information

KENMORE LIMITED WARRANTY

FOR ONE YEAR from the date of sale this appliance is warranted against defects in material or workmanship when it is correctly installed, operated and maintained according to all supplied instructions.

WITH PROOF OF SALE, a defective appliance will receive free repair or replacement at option of seller.

For warranty coverage details to obtain free repair or replacement, visit the web page: www.kenmore.com/warranty

This warranty applies for only 90 DAYS from the sale date in the United States, and is void in Canada, if this appliance is ever used for other than private household purposes.

This warranty covers ONLY defects in material and workmanship, and will NOT pay for:

1. Expendable items that can wear out from normal use, including but not limited to filters, belts, bags or screw-in base light bulbs.
2. A service technician to clean or maintain this appliance, or to instruct the user in correct appliance installation, operation and maintenance.
3. Service calls to correct appliance installation not performed by Sears authorized service agents, or to repair problems with house fuses, circuit breakers, house wiring, and plumbing or gas supply systems resulting from such installation.
4. Damage to or failure of this appliance resulting from installation not performed by Sears authorized service agents, including installation that was not in accord with electrical, gas or plumbing codes.
5. Damage to or failure of this appliance, including discoloration or surface rust, if it is not correctly operated and maintained according to all supplied instructions.
6. Damage to or failure of this appliance, including discoloration or surface rust, resulting from accident, alteration, abuse, misuse or use for other than its intended purpose.
7. Damage to or failure of this appliance, including discoloration or surface rust, caused by the use of detergents, cleaners, chemicals or utensils other than those recommended in all instructions supplied with the product.
8. Damage to or failure of parts or systems resulting from unauthorized modifications made to this appliance.
9. Service to an appliance if the model and serial plate is missing, altered, or cannot easily be determined to have the appropriate certification logo.

Disclaimer of implied warranties; limitation of remedies

Customer's sole and exclusive remedy under this limited warranty shall be product repair or replacement as provided herein. Implied warranties, including warranties of merchantability or fitness for a particular purpose, are limited to one year on the appliance and five years on the sealed system, or the shortest period allowed by law. Seller shall not be liable for incidental or consequential damages. Some states and provinces do not allow the exclusion or limitation of incidental or consequential damages, or limitation on the duration of implied warranties of merchantability or fitness, so these exclusions or limitations may not apply to you.

This warranty applies only while this appliance is used in the United States or Canada*.

This warranty gives you specific legal rights, and you may also have other rights which vary from state to state.

* In-home repair service is not available in all Canadian geographical areas, nor will this warranty cover user or servicer travel and transportation expenses if this product is located in a remote area (as defined by Sears Canada Inc.) where an authorized servicer is not available.

Sears Brands Management Corporation, Hoffman Estates, IL 60179
Sears Canada Inc., Toronto, Ontario, Canada M5B 2C3

Master Protection Agreements

Congratulations on making a smart purchase. Your new Kenmore® product is designed and manufactured for years of dependable operation. But like all products, it may require preventive maintenance or repair from time to time. That's when having a Master Protection Agreement can save you money and aggravation.

The Master Protection Agreement also helps extend the life of your new product. Here's what the Agreement* includes:

- ☑ **Parts and labor** not just for repairing defects, but to help keep products operating properly **under normal use**. Our coverage goes **well beyond the product warranty**. No deductibles, no functional failure excluded from coverage— **real protection**.
- ☑ **Expert service** by a force of more than **10,000 authorized Sears service technicians**, which means someone you can trust will be working on your product.
- ☑ **Unlimited service calls and nationwide service**, as often as you want us, whenever you want us.
- ☑ **"No-lemon" guarantee** – replacement of your covered product if four or more product failures occur within twelve months.
- ☑ **Product replacement** if your covered product can't be fixed.
- ☑ **Annual Preventive Maintenance Check** at your request – no extra charge.
- ☑ **Fast help by phone** – we call it **Rapid Resolution** – phone support from a Sears representative on all products. Think of us as a "talking owner's manual."
- ☑ **Power surge protection** against electrical damage due to power fluctuations.
- ☑ **\$250 Food Loss Protection** annually for any food spoilage that is the result of mechanical failure of any covered refrigerator or freezer.
- ☑ **Rental reimbursement** if repair of your covered product takes longer than promised.
- ☑ **25% discount** off the regular price of any non-covered repair service and related installed parts.

Once you purchase the Agreement, a simple phone call is all that it takes for you to schedule service. You can call anytime day or night, or schedule a service appointment online.

The Master Protection Agreement is a risk free purchase. If you cancel for any reason during the product warranty period, we will provide a full refund. Or, a prorated refund anytime after the product warranty period expires. Purchase your Master Protection Agreement today!

Some limitations and exclusions apply. For prices and additional information in the U.S.A. call 1-800-827-6655.

*** Coverage in Canada varies on some items. For full details call Sears Canada at 1-800-361-6665.**

Sears Installation Service

For Sears professional installation of home appliances, garage door openers, water heaters, and other major home items, in the U.S.A. or Canada call **1-800-4-MY-HOME®**.

First Steps

This Use & Care Guide provides general installation and operating instructions for your model. We recommend using a service or kitchen contracting professional to install your appliance. Use the unit only as instructed in this Use & Care Guide.

Before starting the appliance, follow these important first steps.

Location

- Choose a place that is near a grounded, non-GFCI, electrical outlet. Do Not use an extension cord or an adapter plug.
- For the most efficient operation, the unit should be located where surrounding temperatures will not exceed 110°F (43°C). Temperatures of 32°F (0°C) and below will NOT affect operation. Additional compressor heaters are not recommended.
- Allow space around the unit for good air circulation. Leave a 3 inch (75 mm) space on all sides of the appliance for adequate circulation.

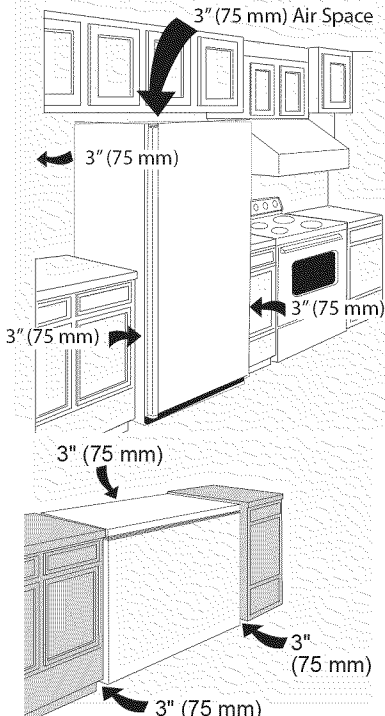

NOTE

The exterior walls of the appliance may become quite warm as the compressor works to transfer heat from the inside. Temperatures as much as 30°F warmer than room temperature can be expected. For this reason it is particularly important in hotter climates to allow enough space for air circulation around your unit.

Leveling

The unit must have all bottom corners resting firmly on a solid floor. The floor must be strong enough to support a fully loaded appliance.

NOTE

It is **Very Important** for your appliance to be level in order to function properly. If the unit is not leveled during installation, the door may be misaligned and not close or seal properly, causing cooling, frost, or moisture problems.

To Level Upright Models:

After discarding crating screws, use a carpenter's level to level the unit from front-to-back. Adjust the plastic leveling feet in front, ½ bubble higher, so that the door closes easily when left halfway open.

To Level Chest Models:

If needed, add metal or wood shims between foot pads and floor.

Cleaning (Prior to use)

- Wash any removable parts, the appliance interior, and exterior with mild detergent and warm water. Wipe dry. **Do not use harsh cleaners on these surfaces.**
- Do not use razor blades or other sharp instruments, which can scratch the appliance surface when removing adhesive labels. Any glue left from the tape can be removed with a mixture of warm water and mild detergent, or touch the residue with the sticky side of tape already removed. **Do not remove the serial plate.**

First Steps



CAUTION

To allow door to close and seal properly, **DO NOT** let food packages extend past the front of shelves.

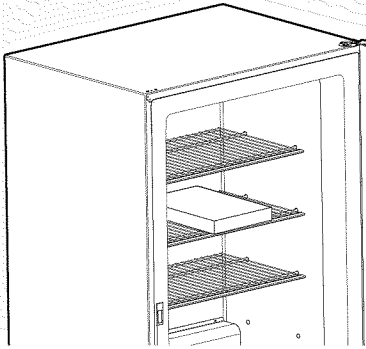

To install the handle clips to the basket:

1. Place the basket on a firm, flat surface.
2. With the narrow side of the handle clip on the inside of the basket, snap the handle clip to the recessed area in the basket.

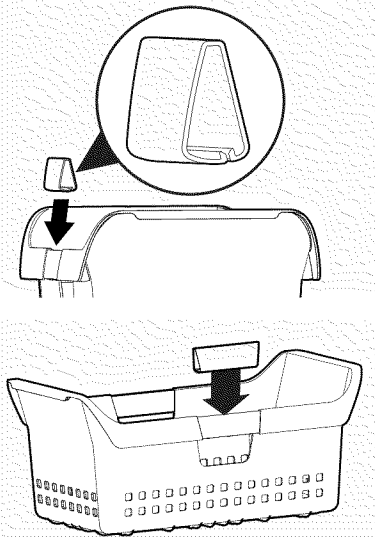

3. Once the inside surface snaps in place, continue the process by rolling the handle clip slightly outward and pressing down firmly to snap onto the outside surface. If installed incorrectly, the handle clip will not lay flat.

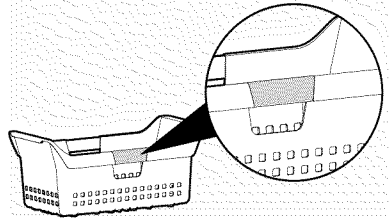

Door Removal If door must be removed:

1. Gently lay the unit on its back, on a rug or blanket.
2. Remove 2 base screws and base panel.
3. Remove wire from clips on bottom of cabinet if required.
4. Unplug connector, if required, by holding the cabinet connector in place and pulling the door connector out.
5. Remove bottom hinge screws.
6. Remove plastic top hinge cover.
7. Remove screws from top hinge.
8. Remove top hinge from cabinet.
9. Remove door and bottom hinge from cabinet.
10. To replace door reverse the above order, and securely tighten all screws to prevent hinge slippage.

Energy Saving Tips



- The appliance should be located in the coolest area of the room, away from heat producing appliances or heating ducts, and out of direct sunlight.
- Let hot foods cool to room temperature before placing in the unit. Overloading the appliance forces the compressor to run longer. Foods that freeze too slowly may lose quality or spoil.
- Be sure to wrap foods properly, and wipe containers dry before placing them in the unit. This cuts down on frost build-up inside.
- Shelves should not be lined with aluminum foil, wax paper, or paper toweling. Liners interfere with cold air circulation, making the unit less efficient.
- Organize and label food to reduce door openings and extended searches. Remove as many items as needed at one time, and close the door as soon as possible.

Setting the Temperature Control

Cool Down Period

- For safe food storage, allow 4 hours for the appliance to cool down completely. The unit will run continuously for the first several hours. Foods that are already frozen may be placed in the appliance after the first few hours of operation. Unfrozen foods should **NOT** be loaded into the unit until the freezer has operated for 4 hours.
- When loading the appliance, freeze only 3 pounds of fresh food per cubic foot of space at one time. Distribute packages to be frozen evenly throughout the unit. It is not necessary to turn the control knob to a colder setting while freezing food.

Temperature Control

Electromechanical Temperature Control (some chest and upright models)

The electromechanical temperature control is located inside the appliance on upright models, and on the left exterior wall on chest models. The temperature is factory preset to provide satisfactory food storage temperatures. However, the temperature control is adjustable to provide a range of temperatures for your personal satisfaction. To adjust the temperature setting, turn the temperature control knob clockwise or counterclockwise. Allow several hours for the temperature to stabilize between adjustments.

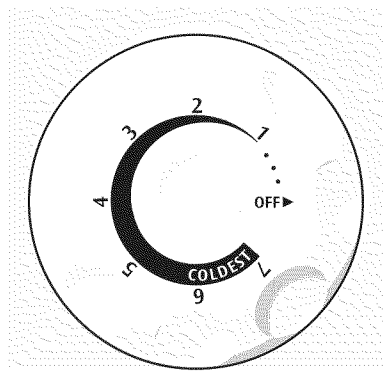

Optional Features

NOTE

Your appliance may have some, or all of the features listed below. Become familiar with these features, and their use and care.

Security Lock with Pop-Out Key

This security lock fastens the door snugly, ensuring stored food is secure. To lock or unlock the freezer, push the key into the lock and turn. The key pops out of the lock after it has been turned.

Blue Defrost Button (some chest

IMPORTANT

It is time to defrost and clean the freezer when the blue defrost button is completely covered with frost.

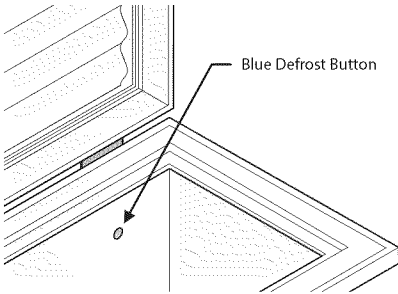

Temp Alarm

This feature is designed to provide a warning if the inside temperature reaches an unsafe level. The temperature feature operates on household electricity. It will not function if household electricity is interrupted.

To silence the alarm, press the set button next to the ALARM OFF indicator on the display or any key on the control panel.

Interior Light

The light comes on automatically when the door is opened. To replace the light bulb, turn the temperature control to OFF and unplug the electrical cord. Replace the old bulb with a bulb of the same wattage.

Adjustable Interior Shelves (some upright models)

Multi-position adjustable interior shelves can be moved to any position for larger or smaller packages. The shipping spacers that stabilize the shelves for shipping may be removed and discarded.

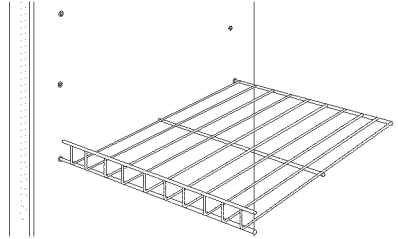

Smart Basket™ System (some chest models)

This basket helps organize odd-shaped items. To reach other packages in the freezer, slide the basket aside or lift out.

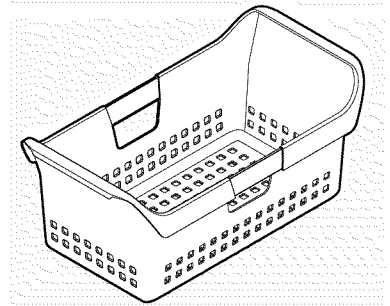

Care & Cleaning



CAUTION

Damp objects stick to cold metal surfaces. Do not touch interior metal surfaces with wet or damp hands.

Some upright freezers are frost-free and defrost automatically, but should be cleaned occasionally.

Between Defrostings

To avoid frequent defrosting, occasionally use a plastic scraper to remove frost. Scrape with a pulling motion. Never use a metal instrument to remove frost.

Defrosting



CAUTION

Freezer must be unplugged (to avoid electrical hazard) from power source when defrosting unit.

It is important to defrost and clean the freezer when $\frac{1}{4}$ to $\frac{1}{2}$ inch of frost has accumulated. Frost may tend to accumulate faster on the upper part of the freezer due to warm, moist air entering the freezer when the door is opened. Remove food and leave the door open when defrosting the freezer.

To Defrost Upright Models with Defrost Drain:

- Remove the drain plug on the inside floor of the freezer by pulling it straight out.
- To access external drain tube on models with a base panel, first remove the two screws from the base panel. Locate the drain tube near the left center under the freezer.
- Place a shallow pan under the drain tube. Defrost water will drain out. Check the pan occasionally so water does not overflow (see figure 1).

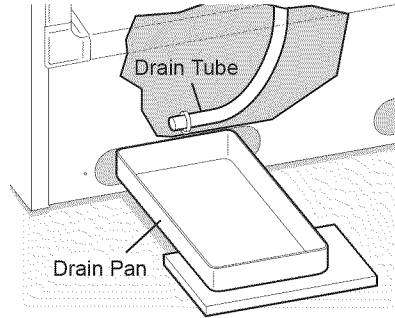

Figure 1

- A $\frac{1}{2}$ inch garden hose adapter can be used to drain the freezer directly into a floor drain. If your model is not equipped with an adapter, one can be purchased at most hardware stores.
- Replace the drain plug when defrosting and cleaning are completed. If the drain is left open, warm air may enter the freezer.

To Defrost Chest Models with Defrost Drain:

- Place a shallow pan beneath the drain outlet. Pull out the outside drain plug (see figure 2). A $\frac{1}{2}$ inch garden hose adapter can be used to drain the freezer directly into a floor drain (see figure 3). If your model is not equipped with an adapter, one can be purchased at most hardware stores.

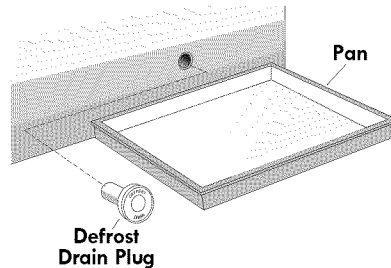

Figure 2

Care & Cleaning

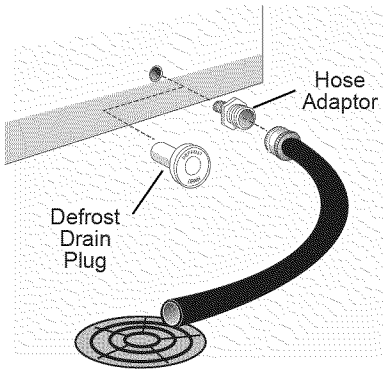

Figure 3

- Pull out the drain plug inside the freezer (see figure 4). Defrost water will drain out. Check pan occasionally so water does not overflow.

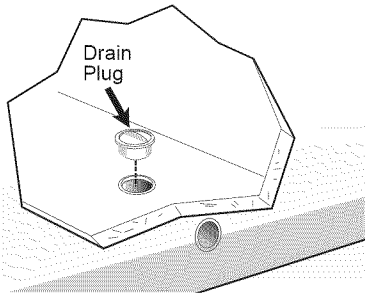

Figure 4

- Replace the drain plugs when defrosting and cleaning are completed. If the drain is left open, warm air may enter the freezer.

To Defrost Models without Defrost Drain:

- Place towels or newspapers on the freezer bottom to catch the frost. The frost will loosen and fall.
- Remove the towels and/or newspapers.
- If the frost is soft, remove it by using a plastic scraper. If the frost is glazed and hard, fill deep pans with hot water and place them on the freezer bottom.
- Close the freezer door/lid. Frost should soften in about fifteen (15) minutes.
- Repeat this procedure is necessary.

Cleaning the Inside

After defrosting, wash inside surfaces of the freezer with a solution of 2 tbsp. (25 g) of baking soda in 1 qt. (1 l) warm water. Rinse and dry. Wring excess water out of the sponge or cloth when cleaning in the area of the controls, or any electrical parts.

Wash the removable parts and door basket with the baking soda solution mentioned above, or mild detergent and warm water. Rinse and dry. **Never** use metallic scouring pads, brushes, abrasive cleaners, or alkaline solutions on any surface. Do not wash removable parts in a dishwasher.

Cleaning the Outside

Wash the cabinet with warm water and mild liquid detergent. Rinse well and wipe dry with a clean soft cloth.



WARNING

If leaving the freezer lid open while on vacation, make certain that children cannot get into the freezer and become entrapped.

To Defrost Chest Models with Defrost Drain:

- Place a shallow pan or the Divider/ Drain Pan (if equipped) beneath the drain outlet. Pull out the outside drain plug (see figure 1). A ½ inch garden hose adaptor can be used to drain the freezer directly into a floor drain (see figure 2). If your model is not equipped with an adaptor, one can be purchased at most hardware stores.
- Remove the drain plug inside the freezer by turning counterclockwise (see figure 3). Defrost water will drain out. Check pan occasionally so water does not overflow.
- Replace the drain plugs when defrosting and cleaning are completed. If the drain is left open, warm air may enter the freezer.

Care & Cleaning

To Defrost Models without Defrost Drain:

- Place towels or newspapers on the freezer bottom to catch the frost. The frost will loosen and fall.

Vacation and Moving Tips

Short Vacations: Leave the freezer operating during vacations of less than three weeks.

Long Vacations: If the freezer will not be used for several months:

- Remove all food and unplug the power cord.
- Clean and dry the interior thoroughly.
- Leave the freezer door open slightly, blocking it open if necessary, to prevent odor and mold growth.

Moving: When moving the freezer, follow these guidelines to prevent damage:

- Disconnect the power cord plug from the wall outlet.
- Remove foods, then defrost, and clean the freezer.
- Secure all loose items such as base panel, baskets, and shelves by taping them securely in place to prevent damage.
- In the moving vehicle, secure freezer in an upright position to prevent movement. Also protect outside of freezer with a blanket, or similar item.

Power/Freezer Failure

NOTE

Do not open freezer door unnecessarily if freezer is off for several hours.

If a power failure occurs, frozen foods will stay frozen for at least 24 hours if the freezer is kept closed. If the power failure continues, pack seven or eight pounds of dry ice into the freezer every 24 hours. Look in the Yellow Pages under Dry Ice, Dairies, or Ice Cream manufacturers for local dry ice suppliers. Always wear gloves and use caution when handling dry ice.

If the freezer has stopped operating, see "Appliance Does Not Run" in the Troubleshooting Guide. If you cannot solve the problem, call an authorized servicer mediately. If the freezer remains off for several hours, follow the directions above for the use of dry ice during a power failure. If necessary, take the food to a local locker plant until the freezer is ready to operate. Look in the Yellow Pages under "Frozen Food Locker Plants".

Before You Call

TROUBLESHOOTING GUIDE	Before calling for service, review this list. It may save you time and expense. This list includes common occurrences that are not the result of defective workmanship or materials in this appliance.	
CONCERN	POTENTIAL CAUSE	COMMON SOLUTION
APPLIANCE OPERATION		
Appliance does not run.	<ul style="list-style-type: none"> • Appliance is plugged into a circuit that has a ground fault interrupt. • Temperature control is in the OFF position. • Appliance may not be plugged in or plug may be loose. • House fuse blown or tripped circuit breaker. • Power outage. 	<ul style="list-style-type: none"> • Use another circuit. If you are unsure about the outlet, have it checked by a certified technician. • See Setting the Temperature Control Section. • Ensure plug is tightly pushed into outlet. • Check/replace fuse with a 15-amp time-delay fuse. Reset circuit breaker. • Check house lights. Call local electric company.
Appliance runs too much or too long.	<ul style="list-style-type: none"> • Room or outside weather is hot. • Appliance has recently been disconnected for a period of time. • Large amounts of warm or hot food have been stored recently. • Door is opened too frequently or too long. • Door may be slightly open. • Temperature Control is set too low. • Gasket is dirty, worn, cracked, or poorly fitted. 	<ul style="list-style-type: none"> • It's normal for the appliance to work harder under these conditions. • It takes 24 hours for the appliance to cool down completely. • Warm food will cause appliance to run more until the desired temperature is reached. • Warm air entering the appliance causes it to run more. Open doors less often. • See "DOOR PROBLEMS" in Before You Call. • Turn control knob to a warmer setting. Allow several hours for the temperature to stabilize. • Clean or change gasket (See "Care and Cleaning Tips"). Worn, cracked or poorly fitting gaskets should be replaced.
Interior temperature is too cold.	<ul style="list-style-type: none"> • The unit is in Express Chill mode. 	<ul style="list-style-type: none"> • Exit Express chill mode by entering into the options menu on the control panel and pressing the "set" button once the indicator is highlighted next to "Express Chill"
Interior temperature is too warm.	<ul style="list-style-type: none"> • Temperature Control is set too warm. • Door is kept open too long or is opened too frequently. • Door may not be seating properly. • Large amounts of warm or hot food may have been stored recently. • Appliance has recently been disconnected for a period of time. 	<ul style="list-style-type: none"> • Turn control to a colder setting. Allow several hours for the temperature to stabilize. • Warm air enters the appliance every time the door is opened. Open the door less often. • See "DOOR PROBLEMS" in Before You Call. • Wait until the appliance has had a chance to reach its selected temperature. • Appliance requires 24 hours to cool down completely.

Before You Call

CONCERN	POTENTIAL CAUSE	COMMON SOLUTION
<p>External surface temperature is warm.</p>	<ul style="list-style-type: none"> • The external walls can be as much as 30°F warmer than room temperature. 	<ul style="list-style-type: none"> • This is normal while the compressor works to transfer heat from inside the cabinet.
SOUND AND NOISE		
<p>Louder sound levels whenever appliance is on.</p>	<ul style="list-style-type: none"> • Modern appliances have increased storage capacity and more stable temperatures. They require a high efficiency compressor. 	<ul style="list-style-type: none"> • This is normal. When the surrounding noise level is low, you might hear the compressor running while it cools the interior.
<p>Longer sound levels when compressor comes on.</p>	<ul style="list-style-type: none"> • Appliance operates at higher pressures during the start of the ON cycle. 	<ul style="list-style-type: none"> • This is normal. Sound will level off or disappear as appliance continues to run.
<p>Popping or cracking sound when compressor comes on.</p>	<ul style="list-style-type: none"> • Metal parts undergo expansion and contraction, as in hot water pipes. 	<ul style="list-style-type: none"> • This is normal. Sound will level off or disappear as appliance continues to run.
<p>Bubbling or gurgling sound, like water boiling.</p>	<ul style="list-style-type: none"> • Refrigerant (used to cool appliance) is circulating throughout the system. 	<ul style="list-style-type: none"> • This is normal.
<p>Vibrating or rattling noise.</p>	<ul style="list-style-type: none"> • Appliance is not level. It rocks on the floor when it is moved slightly. • Floor is uneven or weak. Appliance rocks on floor when it is moved slightly. • Appliance is touching the wall. 	<ul style="list-style-type: none"> • Level the unit. Refer to “Leveling” in the First Steps Section. • Ensure floor can adequately support appliance. Level the appliance by putting wood or metal shims under part of the appliance. • Re-level the appliance or move appliance slightly. Refer to “Leveling” in First Steps.
WATER/MOISTURE/FROST INSIDE APPLIANCE		
<p>Moisture forms on inside walls.</p>	<ul style="list-style-type: none"> • Weather is hot and humid, which increases internal rate of frost build-up. • Door may not be seating properly. • Door is kept open too long, or is opened too frequently. 	<ul style="list-style-type: none"> • This is normal. • See “DOOR PROBLEMS” in Before You Call. • Open the door less often.
WATER/MOISTURE/FROST OUTSIDE APPLIANCE		
<p>Moisture forms on outside of walls.</p>	<ul style="list-style-type: none"> • Door may not be seating properly, causing the cold air from inside the freezer to meet warm moist air from outside. 	<ul style="list-style-type: none"> • See “DOOR PROBLEMS” in Before You Call.

Before You Call

CONCERN	POTENTIAL CAUSE	COMMON SOLUTION
ODOR IN APPLIANCE		
Odor in appliance	<ul style="list-style-type: none"> • Interior needs to be cleaned. • Foods with strong odors are in the appliance. 	<ul style="list-style-type: none"> • Clean interior with sponge, warm water, and baking soda. Replace air filter. • Cover the food tightly.
DOOR PROBLEMS		
Door will not close.	<ul style="list-style-type: none"> • Appliance is not level. It rocks on the floor when it is moved slightly. • Floor is uneven or weak. Appliance rocks on floor when it is moved slightly. 	<ul style="list-style-type: none"> • This condition can force the cabinet out of square and misalign the door. Refer to “Leveling” in First Steps. • Ensure floor can adequately support freezer. Level the floor by using wood or metal shims under the appliance or brace floor supporting the appliance.
LIGHT IS NOT ON		
Light is not on.	<ul style="list-style-type: none"> • The light is burned out or LED light is damaged. • No electric current is reaching the appliance. • Control system has disabled lights because one or both doors were left open too long. • Control is in Sabbath mode (Sb is displayed on control). 	<ul style="list-style-type: none"> • Follow directions in “Interior Light” in the Optional Features section. • See “Appliance does not run” in Before You Call. • Close and reopen door(s) to enable lights. • Depress MODE key and CONTROL LOCK key for 3 seconds.