

INSTALLATION, OPERATION & MAINTENANCE

CONDENSATE NEUTRALIZING SOLUTION
INSTALLATION - OPERATION - MAINTENANCE

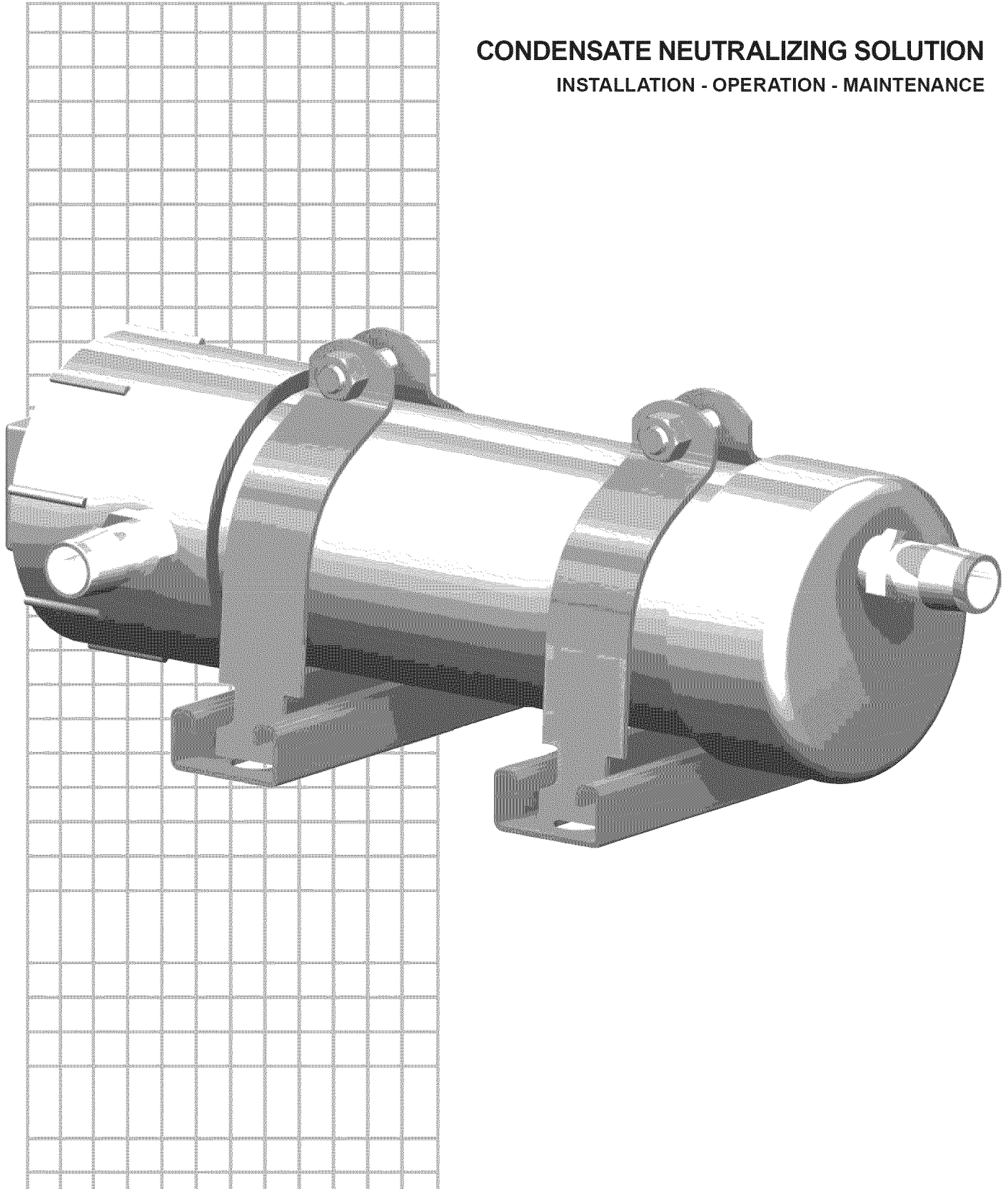

Condensate Neutralizing Solution – Installation, Operation & Maintenance

Overview

Condensate Neutralizing Solution (CNS) increase pH (reduce acidity).

CNS residential and commercial flue-side neutralizing tubes are designed to raise the pH level of the condensate discharged by high-efficiency boilers and water heaters.

Each change of 1.0 in pH is a 10-times reduction (or increase) in concentration. The pH of condensate is increased by approximately 1.0 to 3.0 after passing through CNS tubes. (This is a change in concentration of from 10 to 30 times.)

What is pH?

The pH measurement of a fluid is an indicator of the acidity or alkalinity. Neutral fluids have pH of 7.0. Acid fluids have pH below 7.0. And alkaline fluids have pH above 7.0 (up to 14.0). The pH can be easily measured using litmus paper contained in a pool PH test kit.

Condensate from condensing boilers and water heaters is typically around 4.0 (slightly acidic). The condensate needs to be increased (made more neutral) to prevent possible damage to cast iron soil pipe, ABS pipe, septic tanks, plants, wastewater treatment plants and other materials handling waste water.

Figure 1 CNS Tubes – features and dimensions

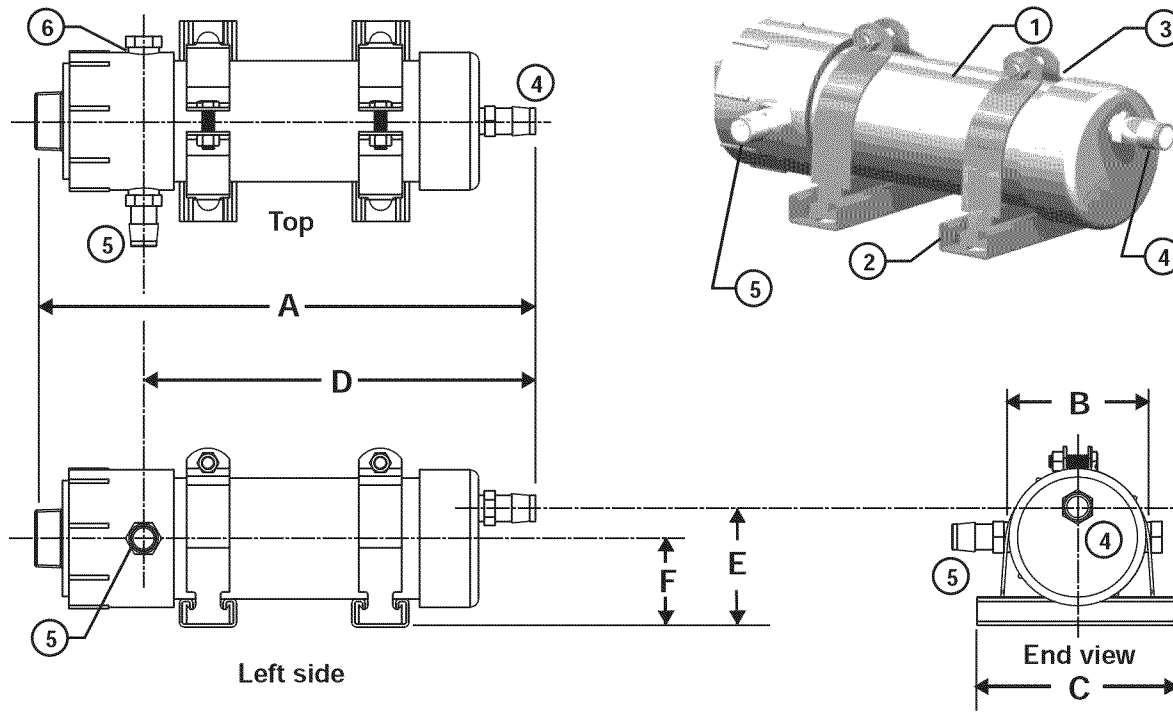

Features		Ratings & Dimensions (in inches)									
Item	Description	Model	MBH	GPH	A	B	C	D	E	F	
1	PVC tubing filled with 1/2" and 3/4" aggregate calcium carbonate	CNS-2	200	2	15	2 3/4	3 7/8	N/A	2 1/4	2 1/4	
2	Channel strut mounts	CNS-6	600	6	14 1/4	4	6	10 3/4	3 1/2	2 1/2	
3	Galvanized strut clamps, bolts and nuts	CNS-10	1,000	10	19	4	6	16 1/8	3 1/2	2 1/2	
4	Condensate outlet hose barb fitting	3/4" hose barb x 1/2" NPT	CNS-20	2,000	20	19 1/2	5	6	16 1/8	4 1/2	3 3/8
5	Condensate inlet hose barb fitting		CNS-30	3,000	30	24 1/2	5	6	21	4 1/2	3 3/8
6	Plugged – alternate location for condensate inlet hose barb fitting										

Applying CNS tubes

Condensate can be collected from flueways and boiler/water heater condensate trap outlets. Use 1 CNS per condensate drain tube for each connection. DO NOT combine condensate lines from flueways with those from boiler/water heater condensate traps. Match the CNS to the Boiler/Water Heater MBH ratings

(see Ratings and Dimensions chart). Locate the CNS tube below the condensate connection and slightly above the floor drain or inlet to a condensate pump reservoir (if used).

Follow the guidelines in this manual, the boiler/water heater manual and all applicable local codes when installing, using and maintaining CNS tubes.

Condensate Neutralizing Solution – Installation, Operation & Maintenance

Installation

<p>WARNING</p> <ul style="list-style-type: none"> Application — Flue gas condensing boilers, water heaters, and breeching condensate drains only. DO NOT exhaust flue gases through CNS tubes, they are not rated for boiler or water heater flue gases. Operating CNS tubes as exhaust vents can cause injury or death from carbon monoxide. DO NOT combine vent condensate drain lines and boiler/water heater condensate lines. Use a separate CNS tube for each application. CNS tubes must be installed below system P-traps, boiler, water heater, and breeching condensate drains. 	<ul style="list-style-type: none"> Gas traps must be installed between the boiler, vent drains, and water heater condensate outlet and the inlet of all CNS tubes. Before operating the boiler or water heater fill the CNS tube and traps with tap water. NEVER operate with tubes or P-traps dry. Tubes should be recharged yearly (every 2,000 operating hours), or when pH level moves below 6. Failure to comply with these guidelines could result in severe personal injury, death or substantial property damage.
--------------------------------------------------------------------------------------------------------------------------------------------------------------------------------------------------------------------------------------------------------------------------------------------------------------------------------------------------------------------------------------------------------------------------------------------------------------------------------------------------------------------------------------------------------------------------------------------------------------------------------------------	------------------------------------------------------------------------------------------------------------------------------------------------------------------------------------------------------------------------------------------------------------------------------------------------------------------------------------------------------------------------------------------------------------------------------------------------------------------------------------------------------------------------------------------------------------------------------

Figure 2 CNS tube application with floor drain, typical

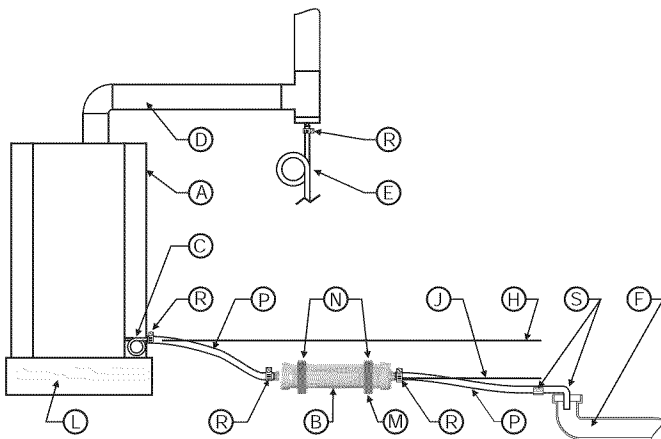
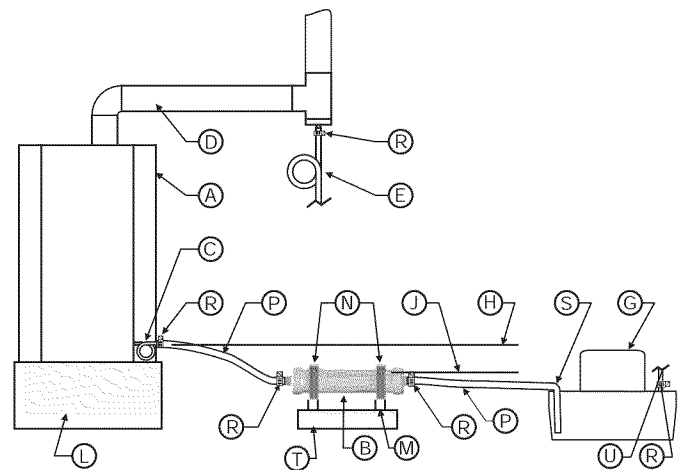

Figure 3 CNS tube application with condensate pump, typical



Legend

- A. Condensing boiler or water heater
- B. CNS tube
- C. Boiler/water heater condensate trap connection
- D. Boiler/water heater vent
- E. Vent condensate trap, when used — Install a trap as shown. Connect the tubing to a separate CNS tube. DO NOT combine with the water heater condensate line.
- F. Floor drain or sump
- G. Condensate pump
- H. Bottom of boiler/water heater condensate outlet — MUST be ABOVE bottom of CNS tube condensate outlet
- J. Bottom of CNS tube condensate outlet
- L. Mounting pad or structural platform, when required to elevate boiler condensate drain as needed
- M. Unistrut bases — bolt to floor, wall or mounting pad
- N. Unistrut clamps — secure tube in position and clamp securely — NOTE that the condensate outlet must be oriented UP, with the condensate inlet into the side.
- P. Plastic tubing or PVC pipe — When using PVC pipe, remove the CNS inlet and outlet hose barb fittings and replace with threaded PVC fittings. Include unions in the piping to allow removal of the CNS tube for inspection and service. — Secure pipe or tubing in place. — Protect with a shield if necessary if routed through traffic areas.

- R. Use hose clamps at all connections when using plastic tubing. (Not applicable for boilers)
- S. Condensate drain termination at floor drain or condensate pump reservoir inlet — secure in place with clamps. — Follow instructions for condensate pump.
- T. Elevate the CNS tube on a structural base if necessary for the outlet to be raised.
- U. Route discharge line from condensate pump assembly per instructions supplied by pump manufacturer.

Installation sequence

1. Securely fasten the two unistrut bases (item M) to floor or wall.
2. Mount tubes (item B) across bases and secure with the two unistrut clamps (item N).
3. Connect plastic tubes or PVC piping from appliance or breeching drains to P-traps (if required) and then from P-trap outlet to either one of the two CNS tube inlets.
4. Connect the CNS tube outlet to house drain or condensate pump.
5. Use Teflon tape on all threaded plastic fittings.
6. NOTE — Always contact the local authority in regards to any requirements concerning flue gas condensate handling codes.

Condensate Neutralizing Solution – Installation, Operation & Maintenance

Maintenance

Inspect monthly

Installer — Instruct the building owner to make a monthly inspection of the CNS tube and all condensate connections. The owner must notify a qualified technician if any problems are noticed.

Recharge annually or every 2,000 operating hours

Installer — Have the building owner schedule an annual (or every 2,000 operating hours) recharge of the CNS tube.

 **WARNING**

- Before operating the boiler or water heater fill the CNS tube and traps with tap water.
- NEVER operate with tubes or P-traps dry.

- Tubes should be recharged yearly (every 2,000 operating hours), or when pH level moves below 6.
- Failure to comply with these guidelines could result in severe personal injury, death or substantial property damage.