

OWNER'S MANUAL

MODEL NOS.

625.348471

625.348491

Caution:
Read and Follow
All Safety Rules and
Operating Instructions
Before First Use of
This Product.

If you have questions when
installing, operating or main-
taining your softener, and
when setting the timer, call
this toll-free number...

1-800-426-9345

SAVE THIS MANUAL



Demand Water Softeners

- ◆ Warranty
- ◆ Start Up / Setting Timer
- ◆ How It Works
- ◆ Care Of
- ◆ Specifications
- ◆ Repair Parts

Use plastic bag and tie provided, to hang manuals nearby
the softener for future reference.

Sears, Roebuck and Co., Hoffman Estates, IL 60179 USA

WARRANTY

SEARS RESIDENTIAL WATER SOFTENER

FULL ONE YEAR WARRANTY ON WATER SOFTENER

For one year from the date of purchase, when this water softener is installed and maintained in accordance with our instructions, Sears will repair, free of charge, defects in material or workmanship in this water softener.

FULL TEN YEAR WARRANTY AGAINST LEAKS

For ten years from the date of purchase, Sears will furnish and install a new current model water softener tank or salt storage drum, free of charge, if either the tank or drum develop a leak.

TO OBTAIN WARRANTY SERVICE, SIMPLY CONTACT THE NEAREST SEARS SERVICE CENTER THROUGHOUT THE UNITED STATES. This warranty applies only while this product is in use in the United States.

This warranty gives you specific legal rights, and you may have other rights which vary from state to state.

Sears, Roebuck and Co., D/817 WA, Hoffman Estates, IL 60179

If you want your water softener professionally installed, talk to your Sears Salesman. He will arrange for a prompt, quality installation by Sears Authorized Installers.

SEARS INSTALLATION POLICY

All installation labor arranged by Sears shall be performed in a neat, workmanlike manner in accordance with generally accepted trade practices. Further, all installations shall comply with all local laws, codes, regulations, and ordinances. Customer shall also be protected, during installation, by insurance relating to Property Damage, Workman's Compensation and Public Liability.

SEARS INSTALLATION WARRANTY

In addition to any warranty extended to you on the Sears merchandise involved, which warranty becomes effective the date the merchandise is installed, should the workmanship of any Sears arranged installation prove faulty within one year, Sears will, upon notice from you, cause such faults to be corrected at no additional cost to you.

FACTS AND FIGURES TO KEEP

Fill in the blanks below and keep this book in a safe place so you always have these facts.

Water Softener Model No. † _____

Serial Number _____

Date Installed _____

Water Hardness _____ Grains Per Gallon

Iron Content _____ Parts Per Million

*pH _____ Taste And/Or Odor _____

Water Pressure _____ Pounds/Square Inch

Water Flow Rate _____ Gallons Per Minute

† The model number is on the rating decal, located on the rim, under the salt hole cover.

TABLE OF CONTENTS

	PAGE NO.
SECTION 1 SOFTENER START UP	
A. SAFETY GUIDES	4
B. CHECK LIST OF STEP-BY-STEP GUIDES TO INSTALL	5
C. PROGRAM THE TIMER	6-7
D. SANITIZING THE WATER SOFTENER	8
E. FILL THE STORAGE TANK WITH SALT	9
SECTION 2 HOW YOUR WATER SOFTENER WORKS	
A. FACE PLATE TIMER FEATURES	10
B. SOFT WATER SERVICE AND REGENERATION	11-13
SECTION 3 CARE OF YOUR SOFTENER	
A. SALT: REFILLING STORAGE TANK, SALT BRIDGE	14
B. KEEPING THE WATER SOFTENER CLEAN	15
C. KEEP THE SOFTENER FROM FREEZING	16
D. HELPFUL HINTS CHECKLIST	17
SECTION 4 OTHER THINGS TO KNOW	
A. DIMENSIONS/SPECIFICATIONS	18
SECTION 5 SERVICE TECH INFORMATION	
A. TROUBLESHOOTING	19-22
B. ROTARY VALVE SERVICE	23
C. WATER FLOW THROUGH THE SOFTENER VALVE	24-26
SECTION 6 REPAIR PARTS	29-31

1A. SAFETY GUIDES

▲ Read all steps, guides and rules carefully before installing and using your new water softener. Follow all steps exactly to correctly install. Failure to follow them could cause personal injury or property damage. Reading this book will also help you to get all of the benefits from your water softener.

▲ Your water softener will remove hardness minerals and “clear water” iron from water, up to the limits shown on page 18. It will not remove other types of iron, acids, tastes and odors, etc. It will not purify polluted water or make it safe to drink.

▲ Protect the softener and piping from freezing. Damage from freezing voids the softener warranty. See page 16.

CAUTIONS

PLEASE READ AND COMPLY WITH THE FOLLOWING GUIDES TO PREVENT DAMAGE TO THE SOFTENER OR OTHER PROPERTY, PERSONAL INJURY, OR POSSIBLE FATAL SHOCK.

▲ THIS SOFTENER WORKS ON 24 VOLTS ONLY. BE SURE TO USE THE TRANSFORMER INCLUDED, AND PLUG IT INTO A 120V OUTLET.

▲ Unplug the transformer right away if the power cable should become damaged or frayed. Make repairs before plugging back into the power outlet.

▲ Always unplug the softener from electrical power before removing outer valve covers.

1B. CHECK LIST OF ALL STEP-BY-STEP GUIDES TO INSTALL

Refer to the Installation Manual, part no. 7159931, for step-by-step guides.

To be sure you have done all the steps to install the softener, read the following list. Page numbers referred to are in the *Installation Manual*.

- ✓ Is the house **water supply flow** going **into** the softener valve **INLET**? Trace piping to be sure. See pages 10 and 11.
- ✓ Is the plumbing bypass valve (or 3 valves) set for soft water **service**? Bypass valve(s) should always remain in soft water service position. Position in "bypass" only if needed for softener repairs. See page 18.
- ✓ Is the valve drain hose connected to the drain fitting the right way? Does the drain hose run to the drain point without sharp bends or kinks that could stop or reduce water flow? See page 16.
- ✓ Is the softener power cable connected to the transformer, and is the transformer plugged into **an inside**, 120V-60Hz electrical outlet? See page 20.
- ✓ Be sure to restart the water heater. See page 20.

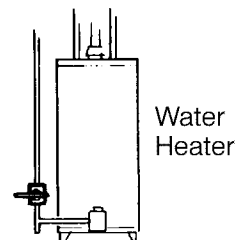
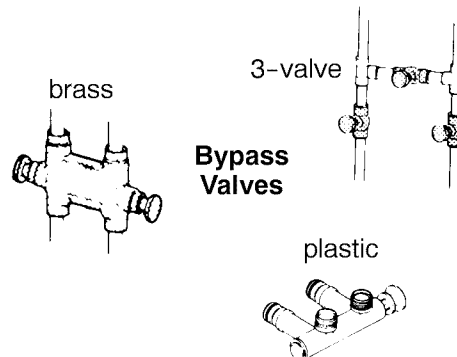
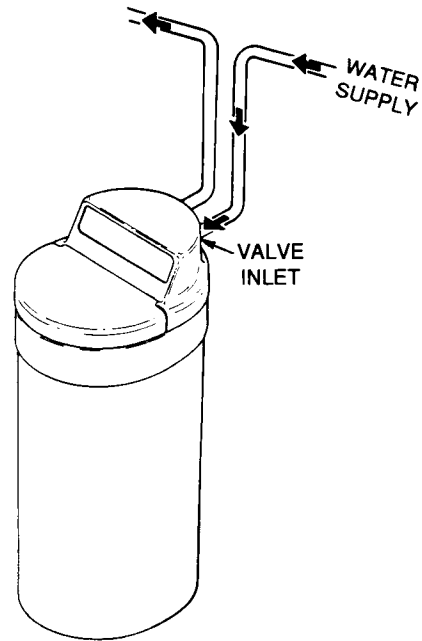

Note, for installations in the State of Massachusetts: **Plumbing codes of Massachusetts shall be adhered to. Consult with your licensed plumber.**

1C. PROGRAM THE TIMER

FIG. 1

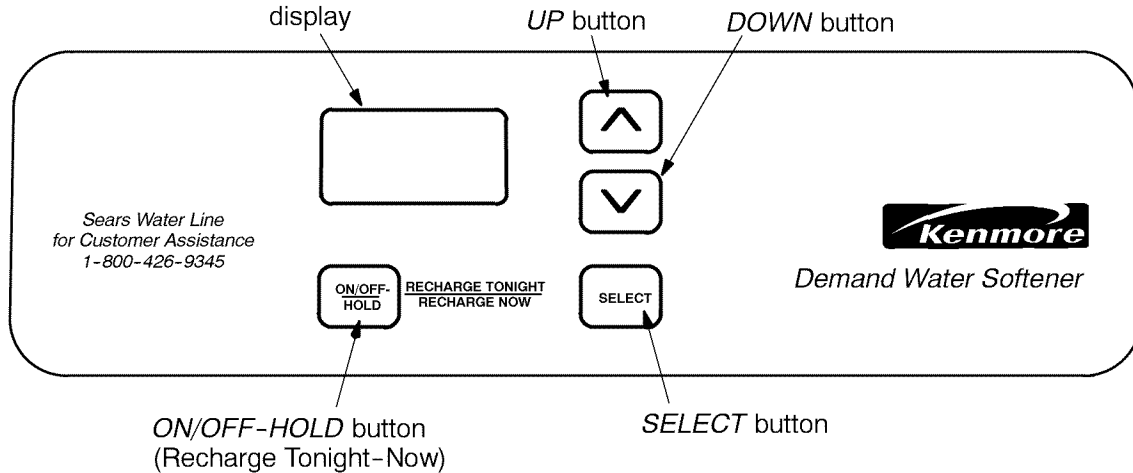

When the transformer is plugged in, a model code shows in the face plate display for the first few seconds. The model code for your water softener is **SR22**, as shown in the following drawing. The model code is followed by a test number (example: S3.0). After the test number, 12:00 AM begins to flash. PRESENT TIME and RECHARGE TONIGHT show at the bottom of the display.

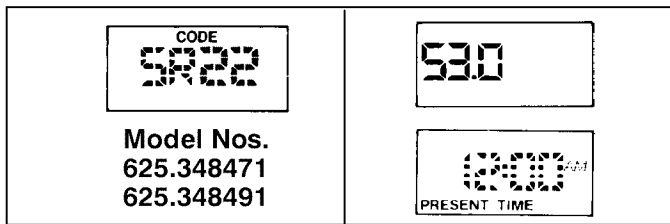

NOTE:

If SR - - is flashing in the display, press the UP button (FIG. 1) until SR22 shows, as needed for your model. **Be sure to set the correct code.** Then, press the SELECT button to display the flashing 12:00 AM. **If other than SR22 shows**, when the transformer is first plugged in, please see page 17 to reset.

SOUND "BEEPER": A "beeper" sounds while pressing buttons for timer set-up. One beep signals a change in the face plate display. Repeated beeps means the timer will not accept a change from the button you have pressed, telling

you to use another button. For example, in setting the hardness (step 2), the beeper sounds repeatedly when the display reaches 1 using the DOWN button, or the highest hardness setting using the UP button.

1. SET PRESENT TIME OF DAY:

NOTE:

If the words PRESENT TIME do not show in the display, press the SELECT button (FIG. 1) until they do.

■ Press the UP/DOWN buttons to set the present time. Press UP to move the display ahead; press DOWN to move the time backward.

If the present time is between noon and midnight, be sure PM shows.



If the present time is between midnight and noon, be sure AM shows.



NOTE:

Each press of the UP or DOWN buttons changes the time by 1 minute. Pressing and holding the buttons changes the time 32 minutes each second.

1C. PROGRAM THE TIMER

2. SET WATER HARDNESS NUMBER:

■ Press the SELECT button once to display 15 (flashing) and HARDNESS.

The grains per gallon (gpg) hardness of your water supply is on your water analysis report. Be sure to enter water test results on page 2, for future reference.



NOTE:

If your water supply contains iron, compensate for it by adding to the water hardness number. For example, assume your water is 15 gpg hard and contains 2 ppm iron. Add 5 to the hardness number for each 1 ppm of iron. In this example, you would use 25 for your hardness number.

$$\begin{array}{r} 15 \text{ gpg hardness} \\ 2 \text{ ppm iron} \times 5 = 10 \\ \text{(times)} \quad \quad \quad \underline{+10} \\ \hline 25 \text{ HARDNESS NUMBER} \end{array}$$

■ Press the UP / DOWN buttons to set your water hardness number in the display. The DOWN button moves the display to 1. The UP button moves the display to the highest setting (see maximum setting for your model in the specifications).

NOTE:

Each press of the UP/DOWN button changes the display by 1 between 1 and 25. Between 25 and the highest number, the display changes 5 at a time...25, 30, 35, etc. Continuous pressure on the UP or DOWN button changes the display twice each second.

3. SET RECHARGE (REGENERATION) TIME:

■ Press the SELECT button once to display 2:00 AM (flashing) and RECHARGE TIME.

At the 2:00 AM RECHARGE TIME setting, the softener begins regeneration (see pages 11 and 12) at 2:00 AM, ending no later than 4:00 AM. This is a good time in most households because water is not being used (see AUTOMATIC BYPASS, page 13).



If a different RECHARGE TIME setting would be better for your household, do the following.

■ Press the UP / DOWN buttons to set the desired RECHARGE starting hour. Be sure to observe the AM-PM as you did when setting the time of day.

NOTE:

Each press of the UP/DOWN buttons changes the display 1 hour. Continuous pressure on the UP or DOWN button changes the display twice each second.

■ Press the SELECT button once again, to return the present time (steady) of day and RECHARGE TONIGHT in the display.



IF YOU NEED HELP PROGRAMMING THE TIMER, CALL TOLL FREE,
NUMBER 1-800- 426- 9345.

SEE PAGE 10 FOR OTHER FACE PLATE TIMER FEATURES.

1D. SANITIZING THE WATER SOFTENER

Care is taken at the factory to keep your water softener clean and sanitary. Materials used to make the softener will not infect or contaminate your water supply, and will not cause bacteria to form or grow. However, during shipping, storage, installing and operating, bacteria could get into the softener. For this reason, sanitizing as follows is suggested when installing.

1. Lift the salt hole cover and use a pail or hose to fill the salt storage tank with at least 3 gallons of water.

2. Remove the brinewell cover and pour about 3/4 ounce (1 to 2 tablespoons) of common 5.25% household bleach into the softener brinewell. Clorox, Linco, BoPeep, White Sail, Eagle, etc., are brand names of bleach readily available.

3. Press the **ON/OFF-HOLD** button and *hold for 3 seconds* to start a recharge. This first recharge does several things.

- It draws the bleach into and through the softener to sanitize it.
- It fills the salt tank to the water level needed.
- It gets all the air out of the resin tank.
- It makes the resin bed (see page 11) ready for soft water service.

NOTES:

This recharge takes about 2 hours.

You can **sanitize** the softener *with or without salt* in the storage tank.

FIG. 2 ADD WATER

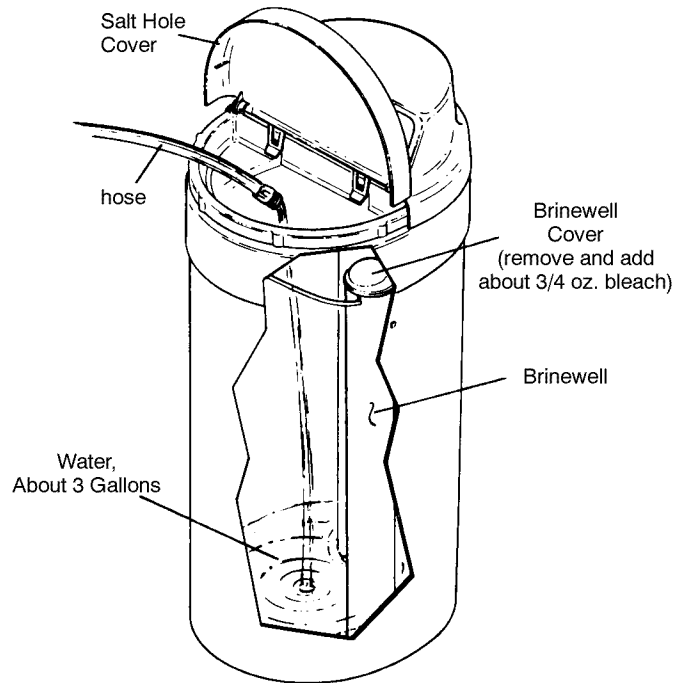

Recommended by the Water Quality Association. On some water supplies, the water softener may need periodic disinfecting. Sanitize with or without salt in the storage tank.

1E. FILL THE STORAGE TANK WITH SALT

Brine (salt dissolved in water) is needed for each and every regeneration. The water for making brine is metered into the salt storage tank by the softener. However, **you must keep the tank filled with salt.**

Fill the tank with NUGGET or PELLET water softener salt. **DO NOT** use rock salts, as they have dirt and sediments that will stop the softener from working.

Before filling, be sure the brinewell cover is in place on the top of the brinewell. Salt storage capacity is shown on page 18.

NOTE:

In humid areas, it is best to fill the storage tank half-full, and to refill it more often. Salt bridging (see page 14) occurs more often when conditions are humid.

Water softening salt with iron removing additives — Some salts have an additive to help the softener handle iron in the water supply. Although this additive may help to keep the softener resin clean, it may also release corrosive fumes that will weaken and shorten the life of some softener parts.

FIG. 3 ADD SALT

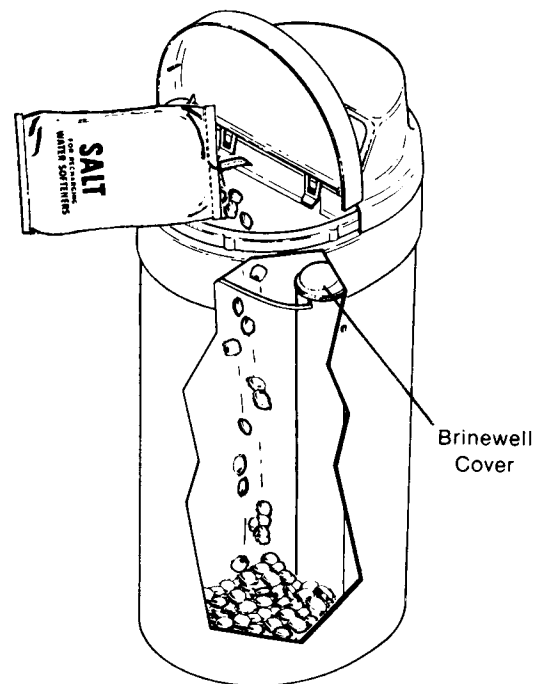

Sodium Information: Water softeners using sodium chloride for regeneration add sodium to the water. Persons who are on sodium restricted diets should consider the added sodium as part of their overall sodium intake.

For example, if your water supply is 15 grains hard, you would have to drink 3 quarts of softened water to consume 335 milligrams of sodium. That is equivalent to eating 2-1/2 slices of white bread.

Persons who are concerned about their drinking water should consider a Sears Drinking Water System that will remove or reduce in excess of 90% of the sodium and other drinking water contaminants.

YOU HAVE NOW FINISHED THE WATER SOFTENER START-UP. AFTER THE SANITIZING RECHARGE, ON PAGE 8, THE SOFTENER WILL BE GIVING YOU SOFT WATER.

2A. FACE PLATE TIMER FEATURES

EXTRA RECHARGE

Sometimes, a manually started regeneration (recharge) may be desired, or needed. Two examples are:

- You have used more water than usual (guests visiting) and you may run out of soft water before the next timer started regeneration.
- You did not refill the softener with salt before it was gone.

You can start a regeneration right away, or you can set the timer to regenerate at the next 2:00 AM (or other preset recharge time). Do the following.

RECHARGE NOW

■ Press the ON/OFF—HOLD button and *hold for 3 seconds*. RECHARGE NOW begins to flash in the display, and the softener enters the fill cycle of regeneration right away. This regeneration will last for about 2 hours. Then, you will have soft water again.



RECHARGE TONIGHT

■ Press and release (**do not hold**) the ON/OFF-HOLD button. RECHARGE TONIGHT flashes in the display, and the softener begins regeneration at the next preset recharge time. If you decide to cancel the regeneration before it has started, press and release the ON/OFF-HOLD button once more to turn off the flashing RECHARGE TONIGHT.



PROGRAM MEMORY

If electrical power to the softener goes off, the time display is blank but the face plate timer keeps the correct time for about 6 hours. When electrical power comes on again, you have to reset the present time **only** if the display is flashing. The HARDNESS and RECHARGE TIME never require resetting unless a change is desired.

Even if the timer is incorrect after a long power outage, the softener works as it should to keep you water soft. However, regenerations may occur at the wrong time of day until you reset the timer to the correct time of day.

ERROR CODE

An error code could appear in the face plate display if a problem occurs in the softener electronics. If you see an error code instead of the time of day, please call you local Sears Service Department for service.

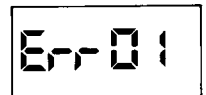

IF YOU NEED HELP ON THE USE OF THE TIMER FEATURES, CALL TOLL FREE, NUMBER 1-800- 426-9345.

2B. SOFT WATER SERVICE AND REGENERATION

SERVICE

When the softener is giving you soft water, it is called "Service". During service, hard water comes from the house main water pipe into the softener. Inside the softener resin tank is a bed made up of thousands of tiny, plastic resin beads (FIG. 4). As hard water passes through the bed, each bead attracts and holds the hardness minerals. This is called ion-exchanging. It is much like a magnet attracting and holding metals. Water without the hardness minerals (soft water) flows out of the softener and into the house soft water pipes.

After a period of time, the resin beads become coated with hardness minerals and they have to be cleaned. This cleaning is called regeneration or recharge. Regeneration is started at 2:00 a.m. by the electronic timer (see page 13). It takes place in 5 stages or cycles. These are:

- | | | | |
|---|-------------|---|------------|
| 1 | FILL | 4 | BACKWASH |
| 2 | BRINING | 5 | FAST RINSE |
| 3 | BRINE RINSE | | |

FIG. 4 WATER FLOW THROUGH THE SOFTENER IN SERVICE

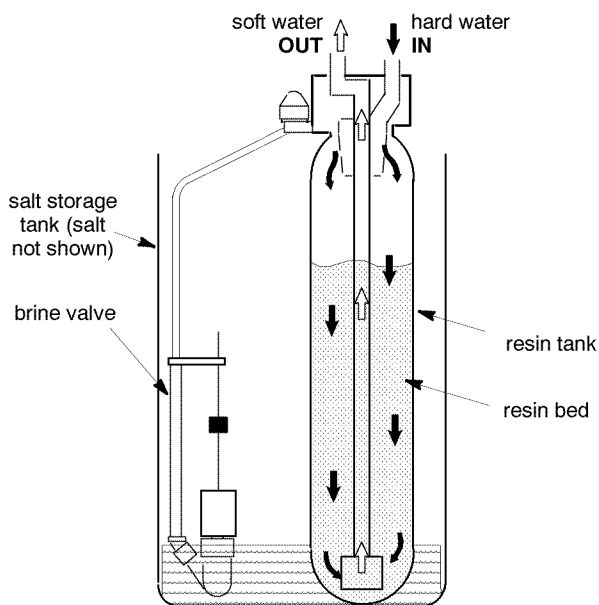

REGENERATION

1 **FILL:** Salt, dissolved in water, is called brine. Brine is needed to clean the hardness minerals from the resin beads. To make the brine, water flows into the salt storage area during the fill stage as shown in FIG. 5. Fill cycle length depends on how much soft water making capacity you have used since the last regeneration. As you use more water, fill time increases so more brine is made. The greater amount of brine cleans more hardness minerals from the resin bed.

FIG. 5 WATER FLOW THROUGH THE SOFTENER IN FILL

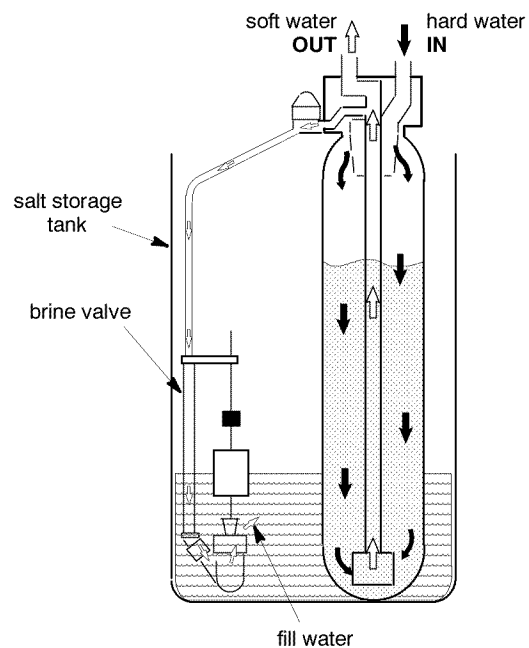

2B. SOFT WATER SERVICE AND REGENERATION

② **BRINING:** During brining, the brine is moved from the salt storage area, into the resin tank. Inside the resin tank, brine cleans hardness minerals from the resin beads and they are discharged out the drain. How much brine is needed to clean the resin depends on:

- the amount of resin in the softener,
- how fast the brine goes through the bed.

The nozzle and venturi (FIG. 6) make suction to take brine from the salt tank and put it into the resin tank. They keep the brine flow down to a very slow rate to get the best resin cleaning with the least salt.

③ **BRINE RINSE:** After all of the brine goes into the resin tank, the brine valve closes. Water keeps flowing the same way it did during brining except the brine flow has stopped. Hardness minerals and brine flush from the resin tank to the drain. Brining and brine rinse together vary in the length of time they take, relative to the fill cycle length.

FIG. 6 WATER FLOW THROUGH THE SOFTENER IN BRINING AND BRINE RINSE

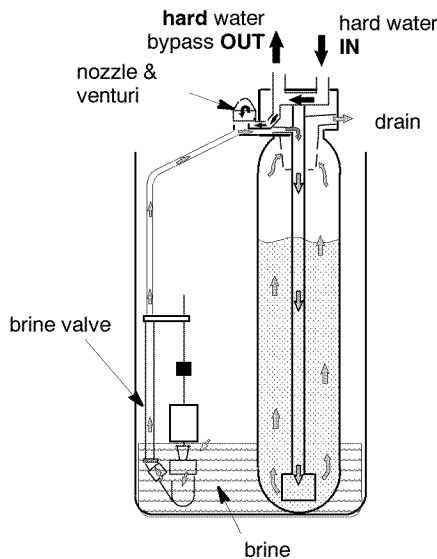

④ **BACKWASH:** During backwash, water flows UP through the resin tank (FIG. 7) at a fast rate to flush iron minerals, dirt and sediments from the bed and to the drain. The bed lifts and expands for good cleaning.

FIG. 7 WATER FLOW THROUGH THE SOFTENER IN BACKWASH

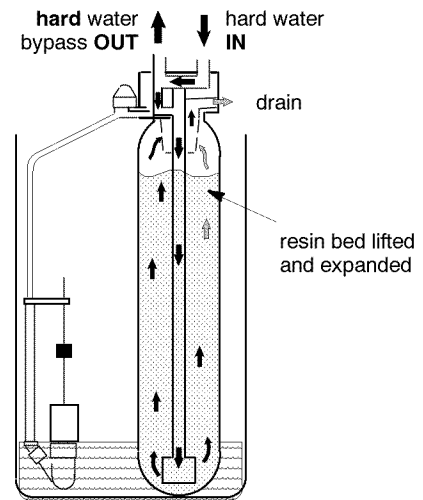

⑤ **FAST RINSE:** Backwash is followed by a fast flow of water down through the resin tank. The fast flow packs the resin bed and gets it ready for return to service (FIG. 8).

After fast rinse, the softener returns to service. Hard water goes into the resin tank where the resin bed again takes out the hardness minerals. Soft water goes to the house soft water pipes.

FIG. 8 WATER FLOW THROUGH THE SOFTENER IN FAST RINSE

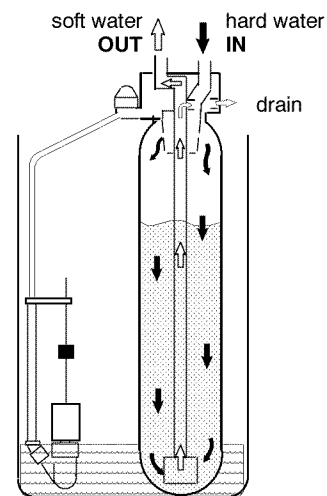

2B. SOFT WATER SERVICE AND REGENERATION

AUTOMATIC BYPASS

During the brining, brine rinse and backwash cycles of regeneration, **hard** water goes through the softener valve and to the house pipes. If a faucet is opened, hard water is there for your needs. However, you should not use **HOT** water, if possible, because the water heater will refill with hard water. The softener regenerates from 2:00 AM to about 4:00 AM, (you can change this time... see page 7). In most homes, 2-4 AM is a time when not much water is used, if any.

If you get up early in the morning and you can hear the softener regenerating, change the time setting. Set the recharge start time to 12:00 AM or 1:00 AM (page 7). Then regeneration will start and end that much earlier and your water heater will not refill with hard water if a hot faucet is opened.

ELECTRONICS

Two main parts of the softener's electronics are ① a WATER METER, and ② a COMPUTER.

① WATER METER — The water meter is in the softener valve outlet. As water flows through the meter, it sends electric pulses to the computer. The computer changes the pulses to a measure in gallons of water.

② COMPUTER — The computer is part of the timer circuit board. It is programmed to know the softener's capacity (how many grains of hardness minerals it will take out of the water before a regeneration is needed). When starting the softener, page 7, you set it for the grains per gallon (gpg) hardness of the water.

To find a regeneration pattern best for your needs, the computer uses: (1) water usage from the meter, (2) hardness setting, (3) softener capacity, and (4) time since the last regeneration. The computer always adjusts this pattern to your water using habits. It works to provide you with soft water for the longest time, at the most efficient salt usage.

Softening capacity is used as hard water goes through the softener and hardness minerals are removed. When the computer determines that only enough capacity remains to provide soft water up to the next regeneration starting time (2:00 AM, or as otherwise set), it will schedule a regeneration. *RECHARGE TONIGHT* displays until the regeneration begins. When the regeneration begins, *TONIGHT* goes off and *RECHARGE NOW* flashes during the 2 hour regeneration.

3A. SALT...REFILLING STORAGE TANK/BREAKING A SALT BRIDGE

WHEN TO REFILL WITH SALT: Check the salt level a few weeks after you install the softener and every week after that. **Refill when the storage tank is about 1/3 full.** Never let the softener use all the salt before refilling. Without salt, you will soon have hard water.

IMPORTANT:

You will have a loss in softening capacity and may get partly hard water if less than 10 inches of salt is in the storage tank.

PLEASE SEE PAGE 9 FOR SALT FILLING DIRECTIONS.

SALT BRIDGE

Sometimes, a hard crust or salt bridge forms in the salt storage tank. It is usually caused by high humidity or the wrong kind of salt. When the salt bridges, an empty space forms between the water and salt. Then salt will not dissolve (melt) in the water to make brine. Without brine, the resin bed does not regenerate and you will have hard water.

If the storage tank is full of salt, it is hard to tell if you have a salt bridge. Salt is loose on top, but the bridge is under it. The following is the best way to check for a salt bridge.

Salt should be loose all the way to the bottom of the tank. Hold a broom handle, or like tool, up to the softener as shown in FIG. 9. Make a pencil mark on the handle, 1" or 2" below the top height of the rim, as shown. Then, carefully push it straight down into the salt. If a hard object is felt before the pencil mark gets to the top of the tank, it's most likely a salt bridge. Carefully push into the bridge in a few places to break it. **Do not try to break the salt bridge by pounding on the outside of the salt tank. You may damage the tank.**

If the wrong kind of salt was the cause of the bridge, take it out. Then fill the tank with nugget or pellet salt only.

FIG. 9 SALT BRIDGE

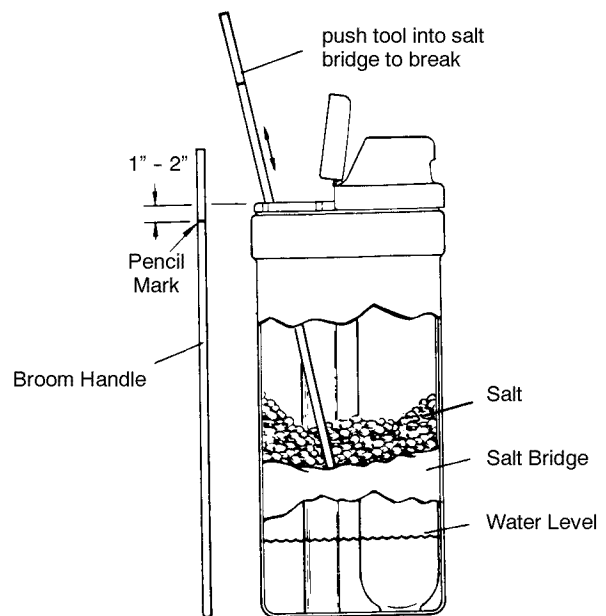

3B. KEEPING THE WATER SOFTENER CLEAN

COVERS

To keep your new Sears water softener looking nice, apply a coat of paste wax and repeat once a year. When dusty, wipe it with a damp cloth to keep it sparkling.

NOZZLE AND VENTURI

A clean nozzle and venturi (FIG. 10) is a must for the softener to work right. This small unit moves brine from the salt storage tank to the resin tank during regeneration. If it becomes plugged with sand, silt, dirt, etc., the softener will not work and you will get hard water.

To get to the nozzle and venturi, remove the softener top cover. Be sure the softener is in service cycle (no water pressure at nozzle and venturi). Then, holding the housing tightly with 1 hand, turn the cap off. **Do not lose the large o-ring seal.** Lift out the screen support and screen, then the nozzle and venturi. Wash and rinse the parts in warm water until clean. If needed, use a small brush to remove iron or dirt. Also check and clean the gasket.

Carefully replace all parts in the correct order. Lubricate the o-ring seal with silicone grease or Vaseline and place in position. Install and tighten the cap, **by hand only. Do not over-tighten and break the cap or housing.**

IRON FROM THE RESIN BED

Your water softener takes hardness minerals (calcium and magnesium) out of the water. Also, it can control some "clear water" iron. See maximum allowed in the specifications on page 18. With clear water iron, water from a faucet is clear when first put into a glass. After 15 to 30 minutes, the water begins to cloud or turn rust colored. A water softener **will not** remove any iron which makes the water cloudy or rusty as it comes from the faucet (called red water iron). **To take red water iron out of water, or over the**

NOTE:

Never use cleaners having ammonia or abrasives. They may scratch and dull the surface.

FIG. 10 CLEANING THE NOZZLE & VENTURI

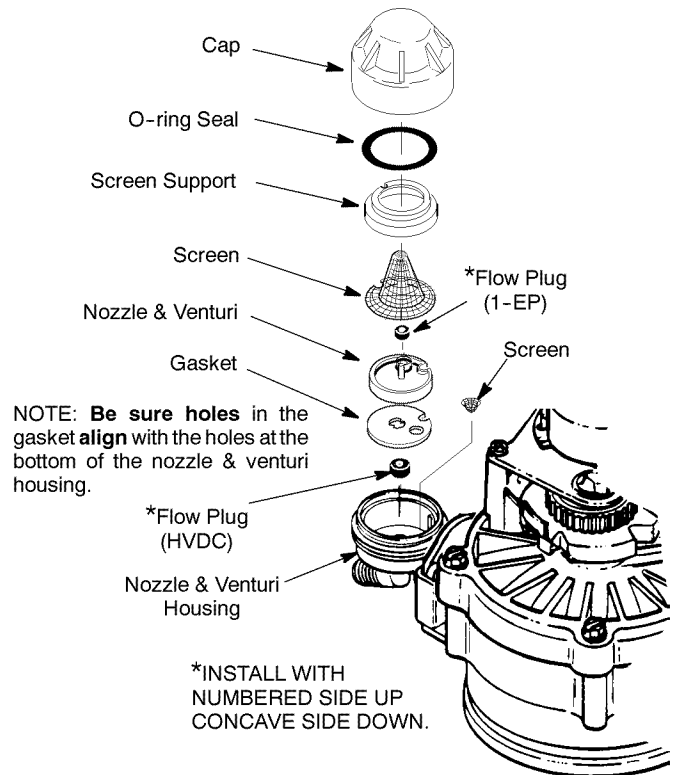

maximum of clear water iron, an iron filter or other equipment is needed. Your local Sears store has trained people to help you with iron water problems.

If your water supply has clear water iron, even though less than the maximum allowed, regular resin bed cleaning is needed. Sears has resin bed cleaner, Stock No. 42-34426 for this. Clean the bed at least every 6 months. If iron appears in the soft water before 6 months, clean more often. Printed instructions are on the resin bed cleaner bottle.

IF YOU HAVE QUESTIONS ABOUT CLEANING AND MAINTAINING YOUR SOFTENER,
CALL TOLL FREE, NUMBER 1-800-426-9345.

3C. KEEP THE SOFTENER FROM FREEZING

If the softener is installed where it could freeze (summer cabin, lake home, etc.), you must drain all water from it to stop possible freeze damage. To drain the softener:

1. Close the shut-off valve on the house main water pipe, near the water meter or pressure tank.
2. Open a faucet in the soft water pipes to vent pressure in the softener.
3. If a single bypass valve is installed, move the stem into bypass. See FIG. 12 on page 18. In a 3-valve bypass system, close the inlet and outlet valve and open the bypass valve. If you want water in the house pipes again, reopen the shut-off valve on the main water pipe.
4. Unplug the transformer at the wall outlet.
5. Remove the salt hole cover and the main cover. Take off both drain hoses.
6. Carefully remove the large holding clips at the softener inlet and outlet (see Key No. 61, on page 30). Separate the softener from the adaptors or bypass valve.
7. Remove the brinewell cover and disconnect the brine valve tubing at the nozzle and venturi assembly (see page 23). Lift the brine valve out of the brinewell. Tip the brine valve upside down to drain out water.

FIG. 11 DRAIN WATER FROM THE SOFTENER

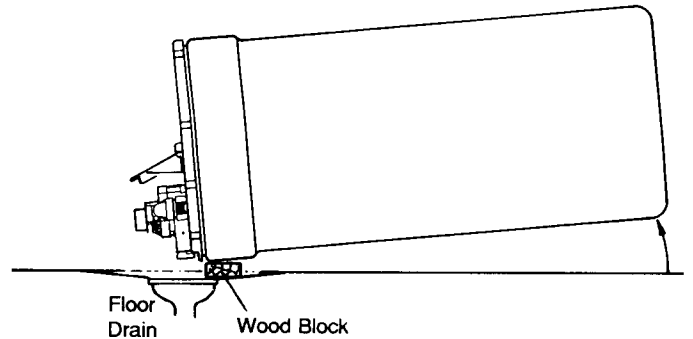

8. Looking at FIG. 11, lay a piece of 2 inch thick board near the floor drain. Move the softener close to the drain. **Slowly and carefully**, tip it over until the rim rests on the wood block with the inlet and outlet over the drain. **Do not allow the softener's weight to rest on the inlet and outlet fittings or they will break.**
9. Tip the bottom of the softener up a few inches and hold *until all water has drained*. Leave the softener laying like this until you are ready to use it. Plug the inlet and outlet with rags to keep dirt, bugs, etc. out.

3D. HELPFUL HINTS CHECKLIST

... TO HELP YOU SAVE MONEY

If your water softener fails to work, make the following easy checks. Often, you will find what's wrong yourself and you won't have to call and wait for service. If, after making the checks, your softener still does not work right, call your Sears Service Department, or call toll free, number 1-800-426-9345 for telephone assistance.

NOTE:

1. Also read ERROR CODE, page 10.

2. If an error code is **not** displayed, press and *hold* the SELECT button until (example: 000- -) shows in the display. Then, press SELECT again and *hold* until an SR code appears. It must show **SR 22** for Model Nos. 625.348471 and 625.348491. If any other SR number shows, the softener computer is working on incorrect input and this would probably be the cause of the problem. To set SR 22, press either the UP or DOWN button. Then, press SELECT to return a flashing 12:00 AM display, and reset the timer on page 6.

You can find the model number of your water softener on the rating decal, on the brine tank rim. See page 28.

PROBLEM	CAUSE	CORRECTION
No soft water	Faucet or fixture may be plumbed to hard water	From the outlet of the water softener, trace the water flow paths in your house pipes. If soft water is not directed to a faucet or fixture where it is wanted, consult a plumber. To conserve salt, the installer may have isolated some fixtures (outside faucets, toilets, etc.) from soft water.
	No salt (or salt bridged) in the storage tank	Refill with salt, or break the salt bridge (page 14). Press ON/OFF-HOLD (RECHARGE NOW) button and hold for 3 seconds to start a regeneration (see page 10).
	Transformer unplugged at the wall outlet, or power cable leads loose, fuse blown, circuit breaker popped, or circuit switched off.	Check for loss of power due to any of these and correct. With the power back on, look at the time display and read PROGRAM MEMORY, page 10.
	Manual bypass valve(s) in bypass position	Look at FIG. 12 on page 18. Move the stem in a single valve to service. In a 3-valve bypass, open the inlet and outlet valves, and be sure to fully close the bypass valve.
	Dirty, plugged or damaged nozzle & venturi	Take apart and clean or replace damaged parts (see page 15).
	Valve drain hose plugged	The drain hose must not have kinks, sharp bends, or be raised too high above the softener (see page 16 in your installation manual).
Water hard sometimes	Hardness number setting too low	Press and release the SELECT button until HARDNESS shows in the display. Read the hardness number in the display and be sure the same grains per gallon number is shown on your water analysis report. See page 7 to reset. Press and release the SELECT button until the present time shows in the display.
	Using hot water when softener is regenerating	Avoid using hot water during this time because the water heater refills with hard water (see Automatic Bypass, page 13).
	Increase in the grains of hardness in your water supply	Ask your Sears retail or catalog store for a new water analysis. Then make a new hardness number setting (page 7).

4A. DIMENSIONS/SPECIFICATIONS

FIG. 12 BYPASS VALVES

Bypass valve(s) should always remain in soft water service position. Position in "bypass" only if needed for softener repairs.

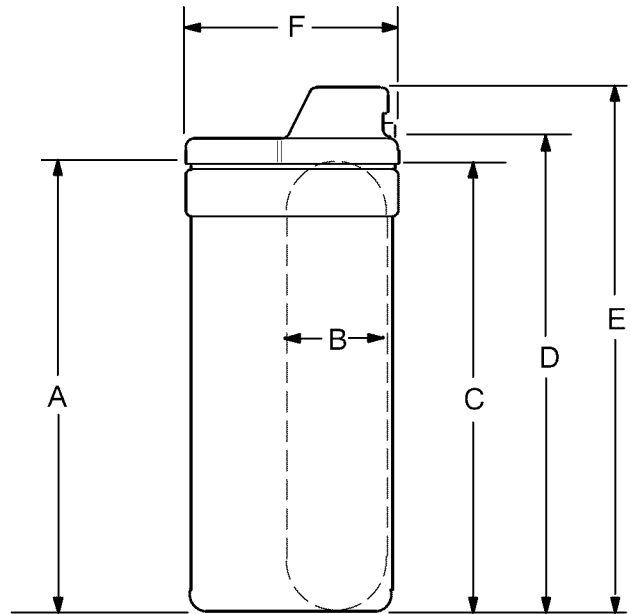
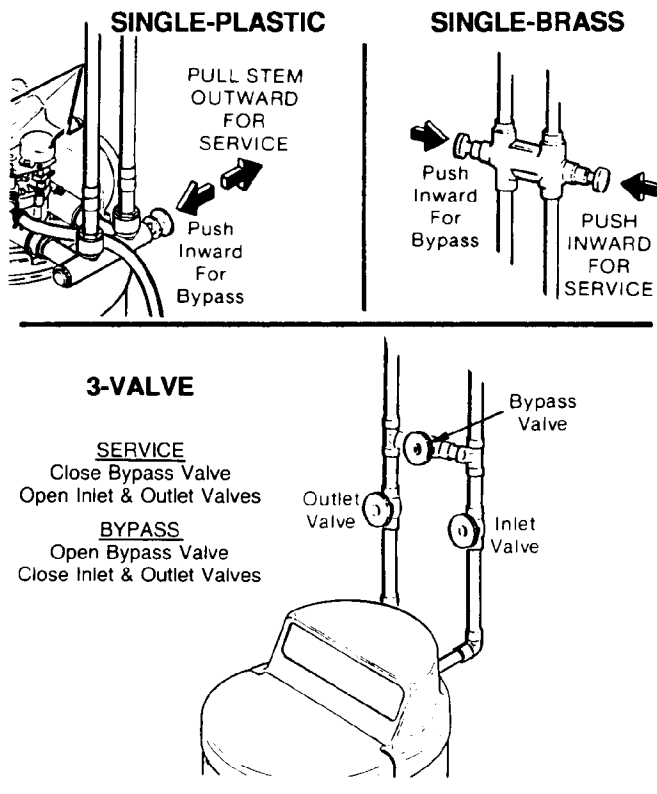

		INCHES	CM
A	Salt Tank Height	40-1/4	102.2
B	Resin Tank Diameter (nominal)	8	20.3
C	Resin Tank Height (nominal)	40	101.6
D	Inlet-Outlet Height	41-1/2	105.4
E	Overall Height	46	116.8
F ¹	Length	19-1/2	49.5
F ²	Width	16-1/2	41.9
—	Distance between inlet-outlet center lines	3-3/8	8.6

MODEL NOS. 625.348471 AND 625.348491, TIMER SR CODE – SR22

NOTE:

Please see the rating decal for water softener operating capacity, salt usage and service flow rate/pressure loss performance specifications. Performance specifications are validated by the Water Quality Association (WQA). The rating decal is located on the rim, under the salt hole cover (see page 28).

WATER SUPPLY TO WATER SOFTENER

MINIMUM WATER SYSTEM FLOW (gpm)	3
MINIMUM – MAXIMUM WATER PRESSURE (psi)	20-120
MAXIMUM WATER TEMPERATURE (°F)	120
MAXIMUM WATER HARDNESS (gpg)	90*
MAXIMUM "CLEAR WATER" IRON (ppm) – 625.348471 and 625.348491	4

SALT FOR WATER SOFTENER

TYPE OF SALT NEEDED	Nugget/Pellet
ALTERNATE TYPE OF SALT	Pure, evaporated, compacted water softener salt
STORAGE CAPACITY (pounds)	200

*Do not exceed this number when setting hardness in step 2, page 7. The maximum setting available is 95.

OTHERS

TYPE OF ION EXCHANGE MATERIAL (resin)	High Capacity
AMOUNT OF RESIN (cu.ft.) – 625.348471 and 625.348491	.70
REGENERATION, or RECHARGE CYCLE TIME (min.)	
FILL	2–8
BRINING/BRINE RINSE	103
BACKWASH	7
FAST RINSE	3
TOTAL REGENERATION TIME	115–121

gpm = gallons per minute
gpg = grains per gallon

psi = pounds per square inch
ppm = parts per million

5A. TROUBLESHOOTING

Keep this manual with your water softener. If repairs are needed, the service technician must have the information on the following pages. For telephone assistance, call toll free, 1-800-426-9345.

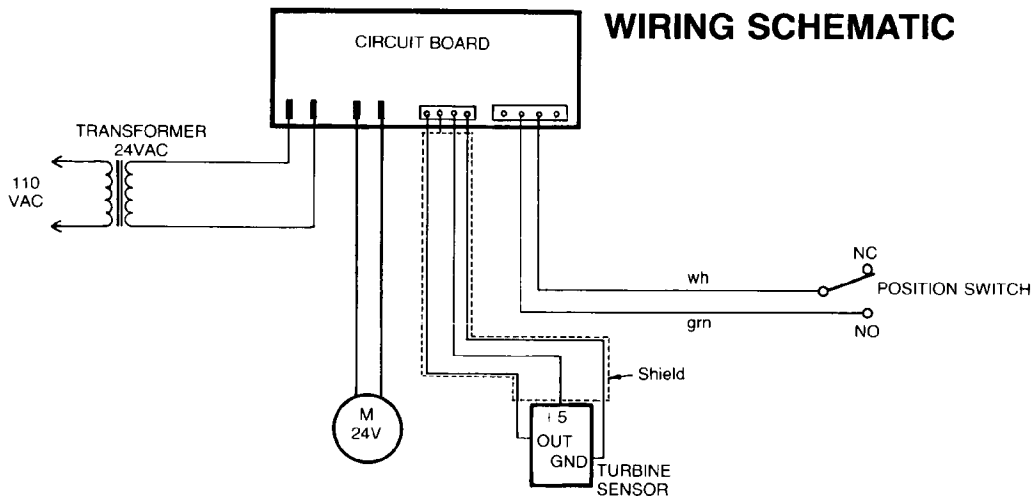

FACEPLATE

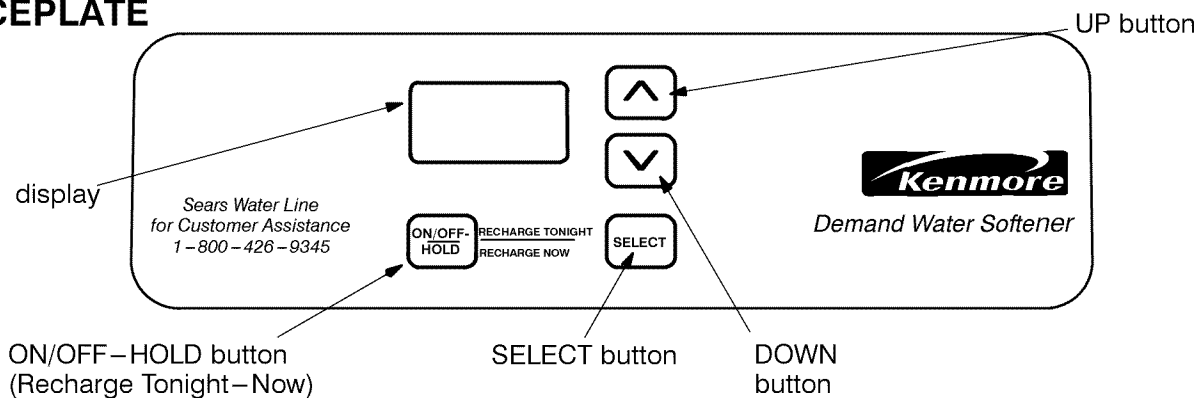

ALWAYS MAKE THESE INITIAL CHECKS FIRST

- Does the time display show the correct time of day?
 - If display is blank, check power source to the softener.
 - If time is flashing, power was off for over 6 hours. The softener resumes normal operation but regenerations occur at the wrong time.
 - If an error code (Example: Err 03) shows in the face plate display, go to *Automatic Electronic Diagnostics*.
- Plumbing bypass valve(s) must be in Full Service position.
- The inlet and outlet pipes must connect to the softener valve inlet and outlet respectively.
- Is the transformer plugged into a "live", grounded wall outlet, and is the power cable fastened securely?
- The valve drain hose must be free of kinks and sharp bends, and not elevated over 8 ft. above the floor.

REMOVE THE TOP COVER AND SALT TANK COVER

- Is there salt in the storage tank?
- Is the brine tubing connected? (See water flow diagrams).
- Is the brine valve float set right? (See page 22).
- Press the SELECT button 2 times to display the hardness setting. Be sure it is the correct setting for the household's water supply. (Make a hardness test of the raw water and compare with the hardness setting. Also test a soft water sample to verify if a problem exists.) Press SELECT twice more to return the time of day display.

If you do not find the problem after making initial checks, do the *Manual Initiated Electronic Diagnostics*, and the *Manual Advance Regeneration Check*.

5A. TROUBLESHOOTING

AUTOMATIC ELECTRONIC DIAGNOSTICS

The face plate computer has a self-diagnostic function for the electrical system (except input power and water meter). The computer monitors the electronic components and circuits for correct operation. If a malfunction occurs, an error code appears in the face plate display.



The chart below shows the error codes that could appear, and the possible defects for each code.

While an error code appears in the display, all face plate buttons are inoperable except the SELECT button. The SELECT button remains operational so the service person can make the Manual Initiated Electronic Diagnostics to further isolate the defect, and check the water meter.

CODE	POSSIBLE DEFECT	
	MOST LIKELY ←	→ LESS LIKELY
Err 01 Err 02 Err 03 Err 04	motor inoperative / wiring harness or connection to switch / position switch / valve defect causing high torque	
Err 05	face plate	

PROCEDURE FOR REMOVING ERROR CODE FROM FACE PLATE: 1. Unplug transformer 2. Correct defect 3. Plug-in transformer 4. Wait for 6 minutes. The error code will return if the defect was not corrected.

MANUAL INITIATED ELECTRONIC DIAGNOSTICS

- To enter diagnostics, press and hold the SELECT button until 000 - - shows in the display.

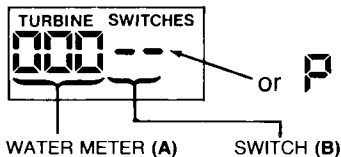

- The first 3 digits indicate water meter operation as follows:

000 (steady) = Soft water not in use, and no flow through the meter.

— OPEN A NEARBY SOFT WATER FAUCET —

000 to 199 (continual) = Repeats display for each gallon of water passing through the meter.

If you don't get a reading in the display, with the faucet open, pull the sensor from the valve outlet port. Pass a small magnet back and forth in front of the sensor. You should get a reading in the display. If you get a reading, unhook the *in* and *out* plumbing and check the turbine for binding.

...

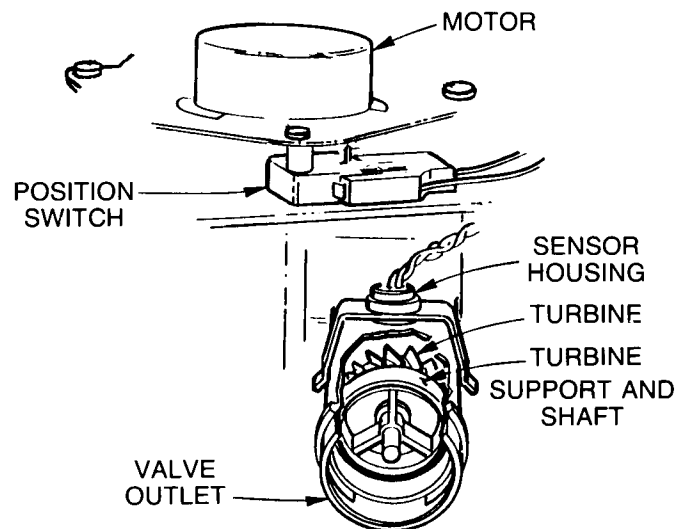

- The letter (P) and dash (or dashes) indicate POSITION switch operation. If the letter appears, the switch is closed. If the dash shows, the switch is open.

Use the ON/OFF-HOLD (Recharge Now) button to manually advance the valve into each cycle and check correct switch operation.

5A. TROUBLESHOOTING

CORRECT SWITCH DISPLAYS	VALVE CYCLE STATUS
- -	Valve in service, fill, brining, back-wash or fast rinse position
- P	Valve rotating from one position to another

C. While in this diagnostic screen, the following information is available and may be beneficial for various reasons. This information is retained by the computer from the first time electrical power is applied to the face plate.

-- Press to display the number of days this face plate has had electrical power applied.

-- Press to display the number of regenerations initiated by this face plate since the SR code number was entered.

2. Press the SELECT button and hold 3 seconds until...

SR 22 shows.
Model Nos. 625.348471
and 625.348491

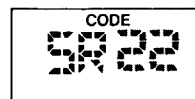

This code identifies the softener nominal capacity size. If the wrong number shows, the softener will operate on incorrect programming. Do the following as needed.

Return the present time display: Press the SELECT button.

Change the SR number: To display the correct SR number, press the UP or DOWN button. Press SELECT, and *reset the timer*.

NOTE:

If the face plate is left in a diagnostic display (or a flashing display when setting times or hardness), present time automatically returns if a button is not pressed within 4 minutes.

FACE PLATE REPLACEMENT: Be sure the valve is in service position (observe valve cycle indicator) when replacing the face plate.

If, after installing and programming the replacement face plate, the valve **is not** in service position, do the following to assure correct cycle orientation, or timing, between the face plate and valve.

Use the MANUAL ADVANCE procedures, page 22. With the RECHARGE NOW button, advance through the recharge cycles until the valve stops in service position, and RECHARGE no longer flashes in the timer.

NOTE: The valve motor may automatically drive through several valve positions while searching for service. If an error code occurs, unplug the transformer, then plug in again

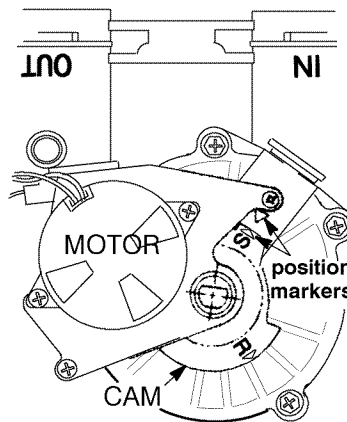

5A. TROUBLESHOOTING

MANUAL ADVANCE REGENERATION CHECK

This check verifies proper operation of the valve motor, brine tank fill, brine draw, regeneration flow rates, and other controller functions. **Always make the initial checks, and the manual initiated diagnostics.**

NOTE: The face plate display must show a steady time (not flashing).

1. Press the ON/OFF-HOLD button and *hold in for 3 seconds*. RECHARGE NOW begins to flash as the softener enters the fill cycle of regeneration. Remove the brinewell cover and, using a flashlight, observe fill water entering the tank.
 - A. If it **does not** enter the tank, look for an obstructed nozzle, venturi, fill flow plug, brine tubing, or brine valve riser pipe.

CYCLE FLOW RATES (GALLONS PER MIN.)	
FILL (flow to salt storage tank)	0.3 (1.1 liters)
BRINING	.16 (.6 liters)
BRINE RINSE	.11 (.4 liters)
BACKWASH	1.8 (6.8 liters)
FAST RINSE	1.8 (6.8 liters)

} (flow to drain)

2. After observing fill, press the ON/OFF-HOLD button to move the softener into brining. A slow flow of water to the drain will begin. Verify brine draw from the brine tank by shining a flashlight into the brinewell and observing a noticeable drop in the liquid level.

NOTE: Be sure a salt bridge is not preventing water with salt contact.

- A. If the softener does not draw brine:
 - nozzle and/or venturi dirty or defective.
 - nozzle and venturi not seated properly on gasket.
 - restricted drain (check drain fitting and hose).
 - defective nozzle and venturi seal.
 - other inner valve defect (rotor seal, rotor & disc, wave washer, etc.).

NOTE: If water system pressure is low, an elevated drain hose may cause back pressure, stopping brine draw.

3. Again press ON/OFF-HOLD to move the softener into backwash. Look for a fast flow of water from the drain hose.
 - A. An obstructed flow indicates a plugged top distributor, backwash flow plug, or drain hose.
4. Press ON/OFF-HOLD to move the softener into fast rinse. Again look for a fast drain flow. Allow the softener to rinse for a few minutes to flush out any brine that may remain in the resin tank from the brining cycle test.
5. To return the softener to service, press ON/OFF-HOLD.

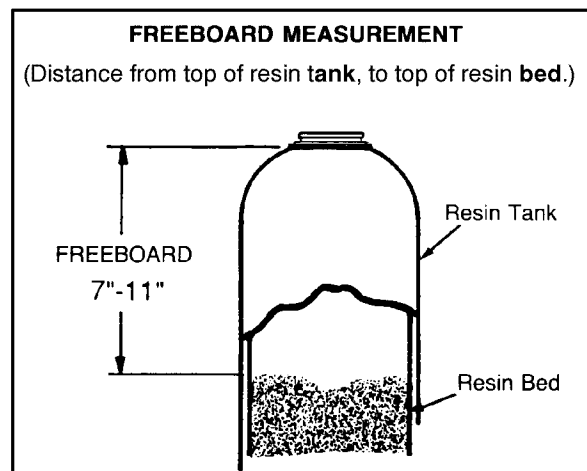
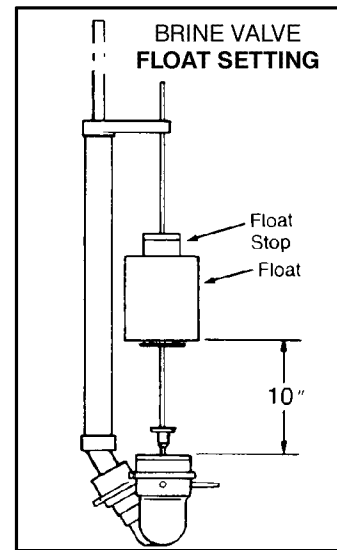

5B. ROTARY VALVE SERVICE

Before working on the valve, **turn off the water supply and disconnect from electrical power.**

TO RELIEVE PRESSURE

- **3 VALVE BYPASS:** Close the inlet valve and open a soft water faucet. Then close the outlet valve and open the bypass valve.

- **SEARS SPECIAL BYPASS:** Slide the bypass valve stem to bypass position. Loosen the 3 hex head screws (see A in drawing) toward the backside of the valve to allow pressure water to bleed out. Catch the water with a rag.

DISASSEMBLY

To remove a part or group of parts, refer to the valve drawing. A common screwdriver or nut driver, Phillips screwdriver and pliers are the only tools needed to completely disassemble.

SERVICING THE VALVE

Inspect all o-rings, seals and gaskets for wear or defects.

Inspect the bottom surface of the rotor and disc for scratches, chips or wear.

NOTE: If replacement is needed, be sure to use the current replacement part.

ASSEMBLY

Be sure all parts are in place and in the proper position. Lubricate ALL o-rings and seals with FDA approved silicone grease. To install the rotor seal, first place the seal into the valve groove, rounded side down (see cross-section). Apply a light coating of silicone grease to the seal's crossing ribs. Then, carefully center the wear strip on the seal, and push it downward onto the seal.

Install the nozzle and venturi seal and drain seal. Assemble 2 o-rings and the wave washer onto the rotor and disc. Then center the rotor and disc, in the valve body, on the rotor seal.

Lower the cover onto the valve body and rotor shaft. Then install the cover holding screws. **Before tightening the screws, install the valve cam and gear. Then, turn the rotor (CLOCKWISE ONLY) to SERVICE position.** Tighten the screws using a

criss-cross pattern. If a torque wrench is available, torque to 30-40 inch pounds.

Lubricate the gear on the motor, and the valve cam gear with Molykote grease, or other high quality gear lubricant.

Be sure to orient the switch as shown, with the lever toward the cam.

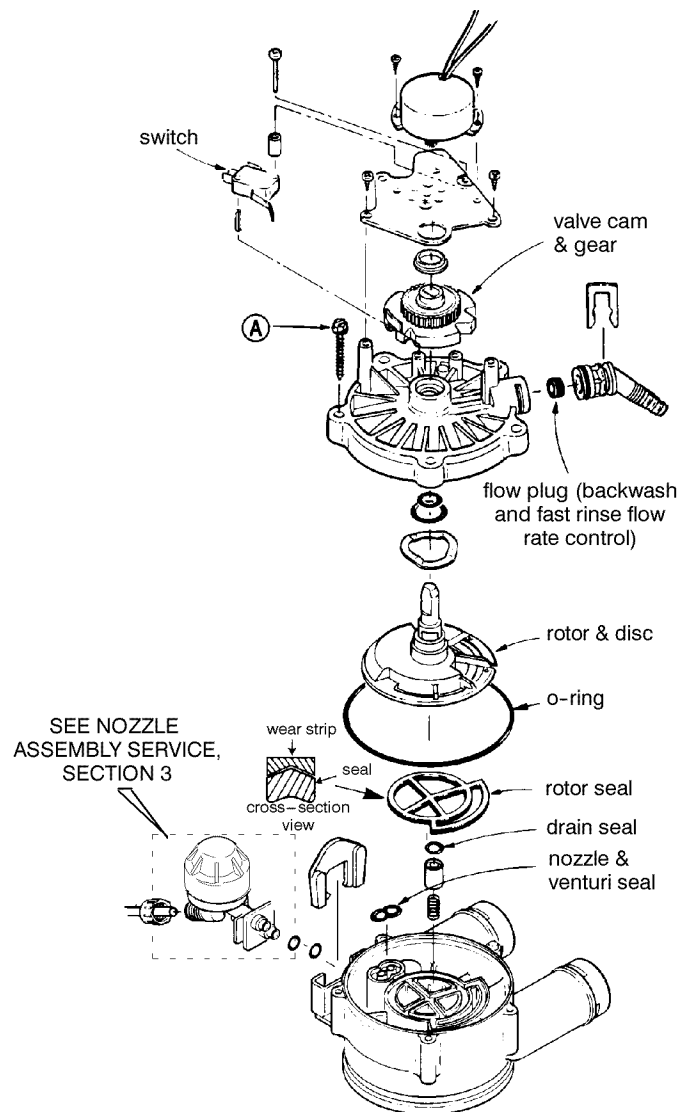

5C. WATER FLOW THROUGH THE SOFTENER VALVE

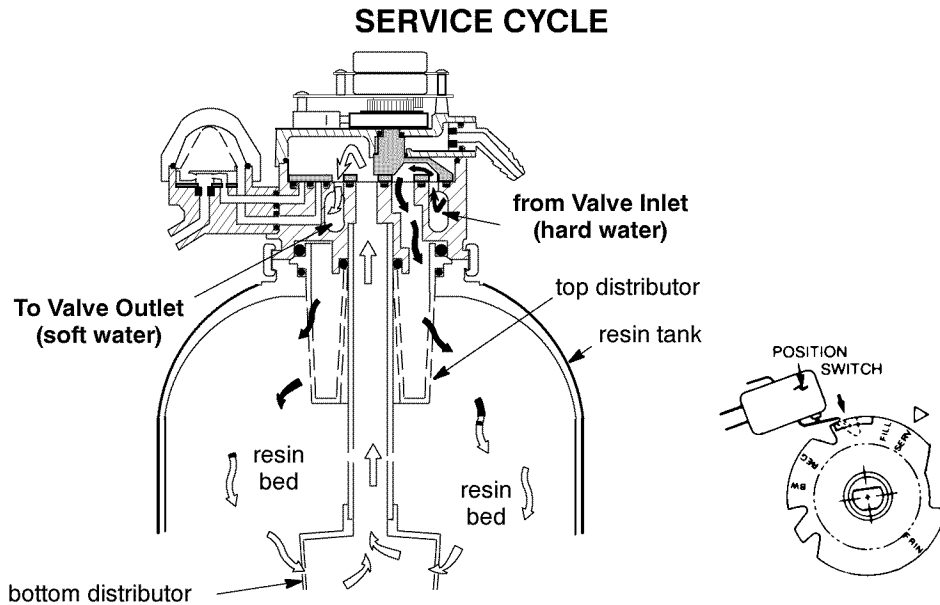

Hard water enters the valve inlet port. Internal valve porting routes the water down and out the top distributor, into the resin tank. Hard water is softened as it passes through the resin bed, then enters the bottom distributor. Soft water flows back into the valve and out the valve outlet, to the house soft water pipes.

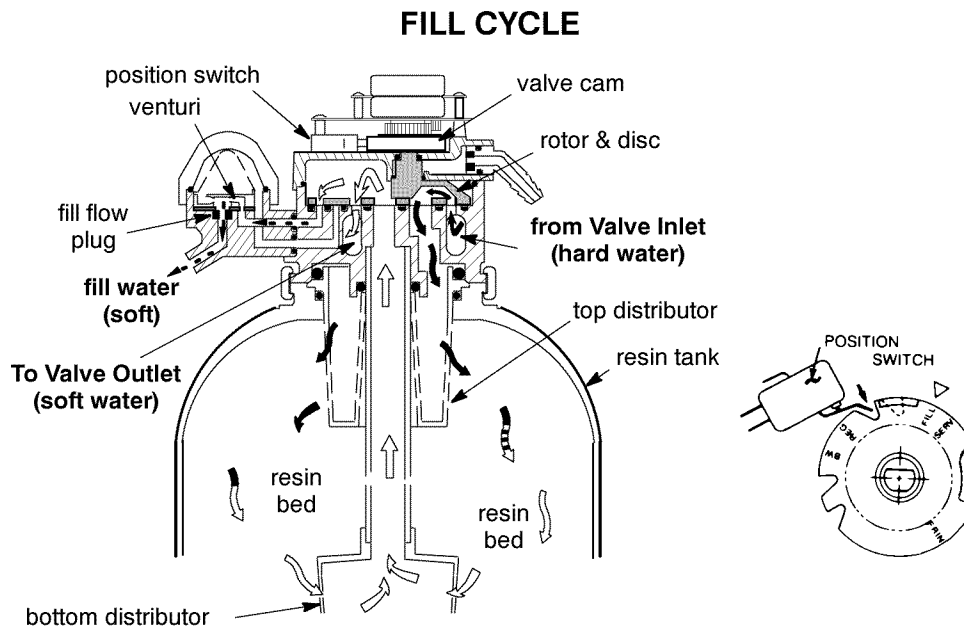

To begin a regeneration, the electroic timer energizes the circuit to the valve motor. The valve motor rotates the rotor and disc and the valve cam until the position switch lever drops, to open the motor circuit and position the valve in FILL. As the rotor and disc rotates, the port opens for SOFT water fill through the venturi. Fill flow continues to the brine valve, and into the salt storage tank. Soft water is still available to the house lines.

5C. WATER FLOW THROUGH THE SOFTENER VALVE

BRINING AND BRINE RINSE CYCLES

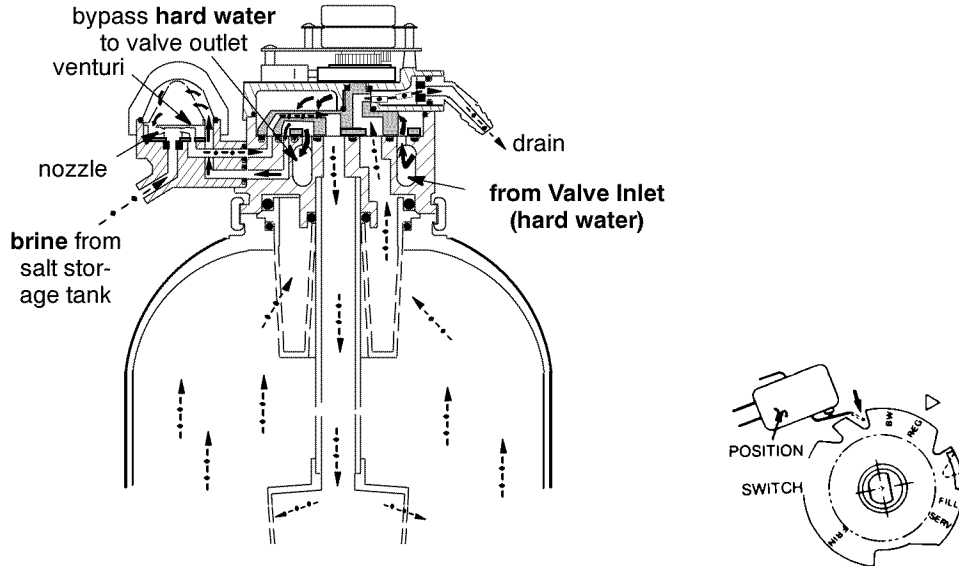

After fill, timer/switch action allows the motor to turn the rotor and disc into BRINING position. Water flow is directed to the nozzle. Suction, created by the nozzle and venturi, draws brine from the salt storage tank and injects it into the resin bed via the bottom distributor. Flow continues out the top distributor and to the drain. Hard water is available at the valve outlet.

When the brine valve closes to end brine draw, water flow continues in the same directions to slowly RINSE brine from the resin bed and to the drain.

BACKWASH CYCLE

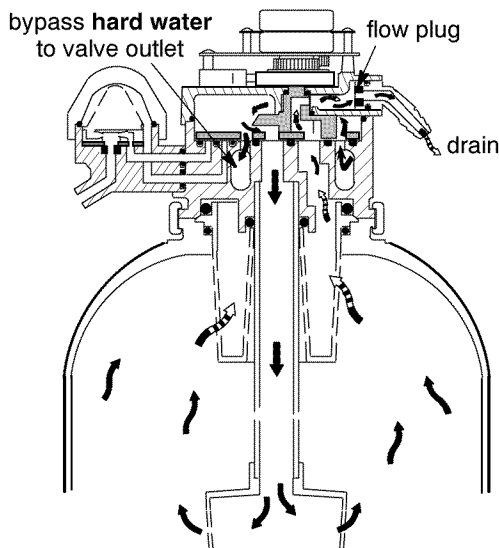

Timer/switch action again allows the motor to turn the rotor & disc to place the valve in BACKWASH, stopping water flow to the nozzle. Water is routed down and out the bottom distributor, up through the bed, and out the top distributor to the drain. The fast flow (controlled by a flow plug in the drain fitting) flushes dirt, sediments, iron deposits, remaining brine and hardness to the drain.

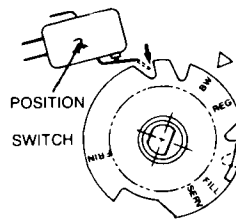

5C. WATER FLOW THROUGH THE SOFTENER VALVE

FAST RINSE CYCLE

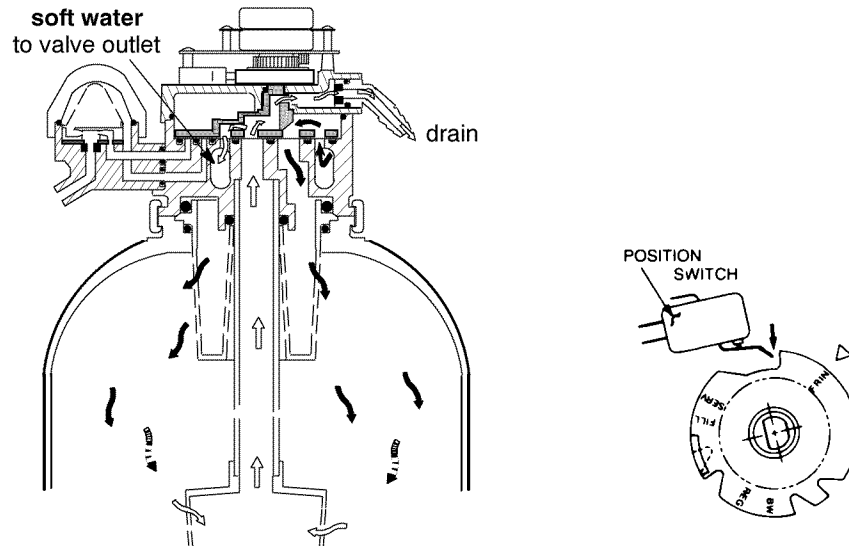

During FAST RINSE, the rotor & disc is positioned so water flow enters the resin tank through the top distributor, and exits through the bottom distributor, to the drain.

The electronic timer again energizes the motor to return the valve to *service*. As the valve rotates, the position switch lever drops to open the circuit. The valve remains positioned in service until the electronic timer initiates the next regeneration.

NOTES

SEARS WATER SOFTENERS MODEL NOS. 625.348471 AND 625.348491

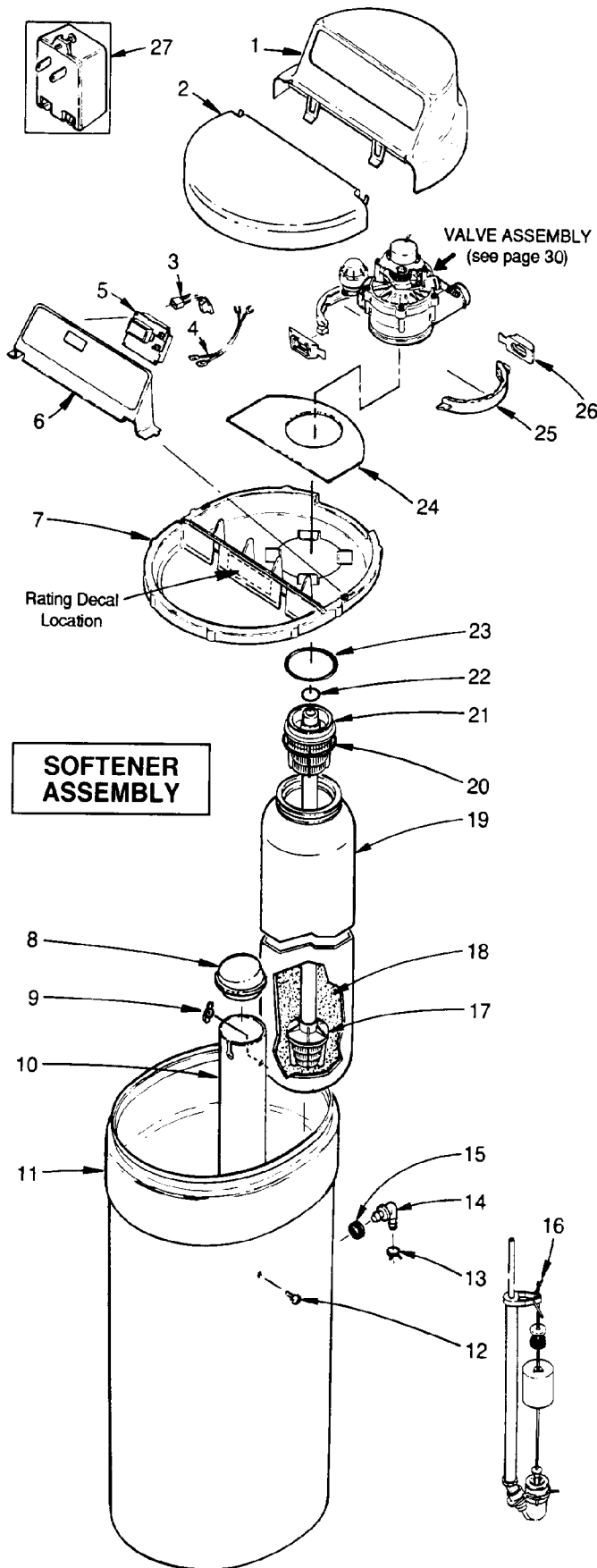

KEY NO.	PART NUMBER	DESCRIPTION
1	7137604	Cover (main)
2	7137612	Salt Hole Cover
3	7118333	Wire Harness (switch)
4	7132840	Power Cord (transformer)
5	7144960	Timer Repl. (PWA)
6	7137620	Face Plate (order req'd decal)
	7170466	Face Plate Decal, Mod 625.348471
	7170458	Face Plate Decal, Mod 625.348491
7	7137599	Rim
8	7137727	Brinewell Cover
9	7082150	Wing Nut, 1/4"
10	7100819	Brinewell
11	7144619	Salt Storage Tank
12	7148875	Screw, Plastic, 1/4" x 5/8"
13	0900431	Tube Clamp ●▲
14	1103200	Tube Adaptor ●▲
15	9003500	Grommet ●▲
16	7116488	Brine Valve Assy. (also see pg. 29)
17	7105047	Replacement Distributor
18	0501744	Resin
19	7092155	Resin Tank (Incl. Key No. 18)
20	7170270	O-Ring, 2-3/4" x 3"
21	7077870	Top Distributor
22	7170254	O-Ring, 13/16" x 1-1/16"
23	7170296	O-Ring, 2-7/8" x 3-1/4"
24	7141001	Vapor Barrier
25	7176292	Clamp Section (2 req.)
26	7088033	Clamp Retainer (2 req.)
27	7095373	Transformer, 24V-10VA ●▲
◆	7159931	Installation manual
◆	7198985	Owners Manual

◆ not illustrated

●▲ Included in parts bags. See page 31.

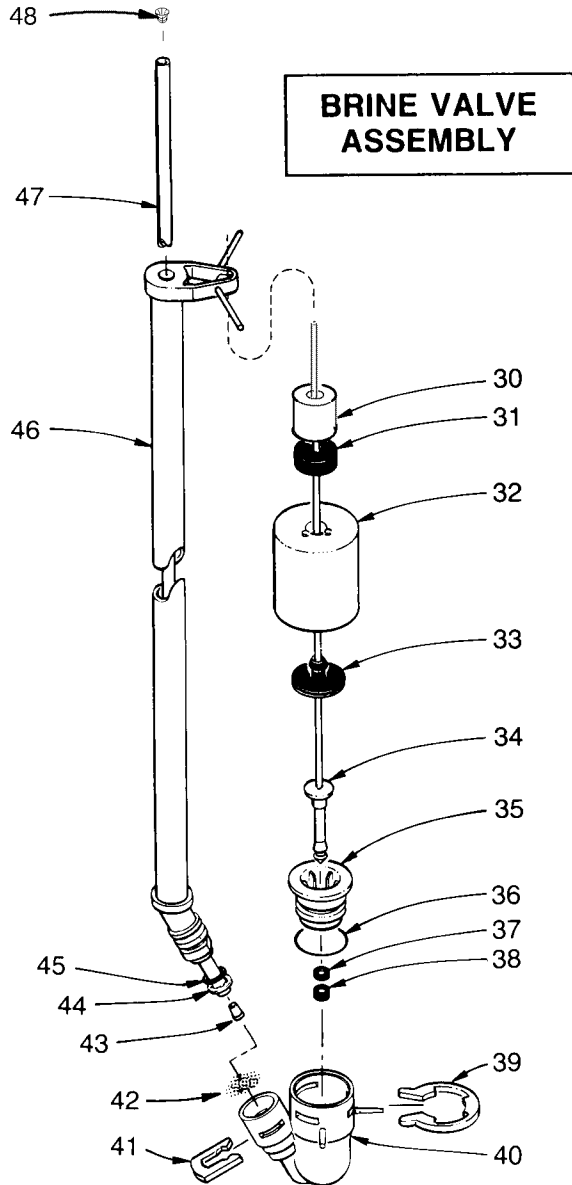

SEARS WATER SOFTENERS MODEL NOS. 625.348471 AND 625.348491

KEY NO.	PART NUMBER	DESCRIPTION
30	7168647	Ceramic Weight
31	0513860	Float Stop
32	7097202	Float (Includes Key No. 33)
33	0516947	Float Seal
34	7093216	Float Rod & Stem
35	7092278	Guide Cap
36	7170288	O-Ring 15/16 x 1-3/16
37	0516211	Seal
38	0516924	Retainer, Bottom Seal
39	7116713	Clip
40	7092252	Brine Valve Body
41	7080653	Clip
42	7131365	Screen
43	7094979	Insert
44	7092294	Retaining Ring
45	7176161	O-Ring, 5/16 x 9/16
46	7095470	Brine Tube
47	7113016	Tubing Assy. (Incl. Key Nos. 43, 44 & 45)
48	7171349	Cone Screen
49	7112997	Ground Clamp Kit ●▲

●▲ Included in parts bag. See page 31.

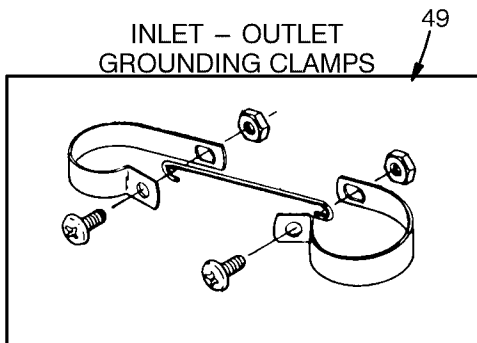

SEARS WATER SOFTENERS MODEL NOS. 625.348471 AND 625.348491

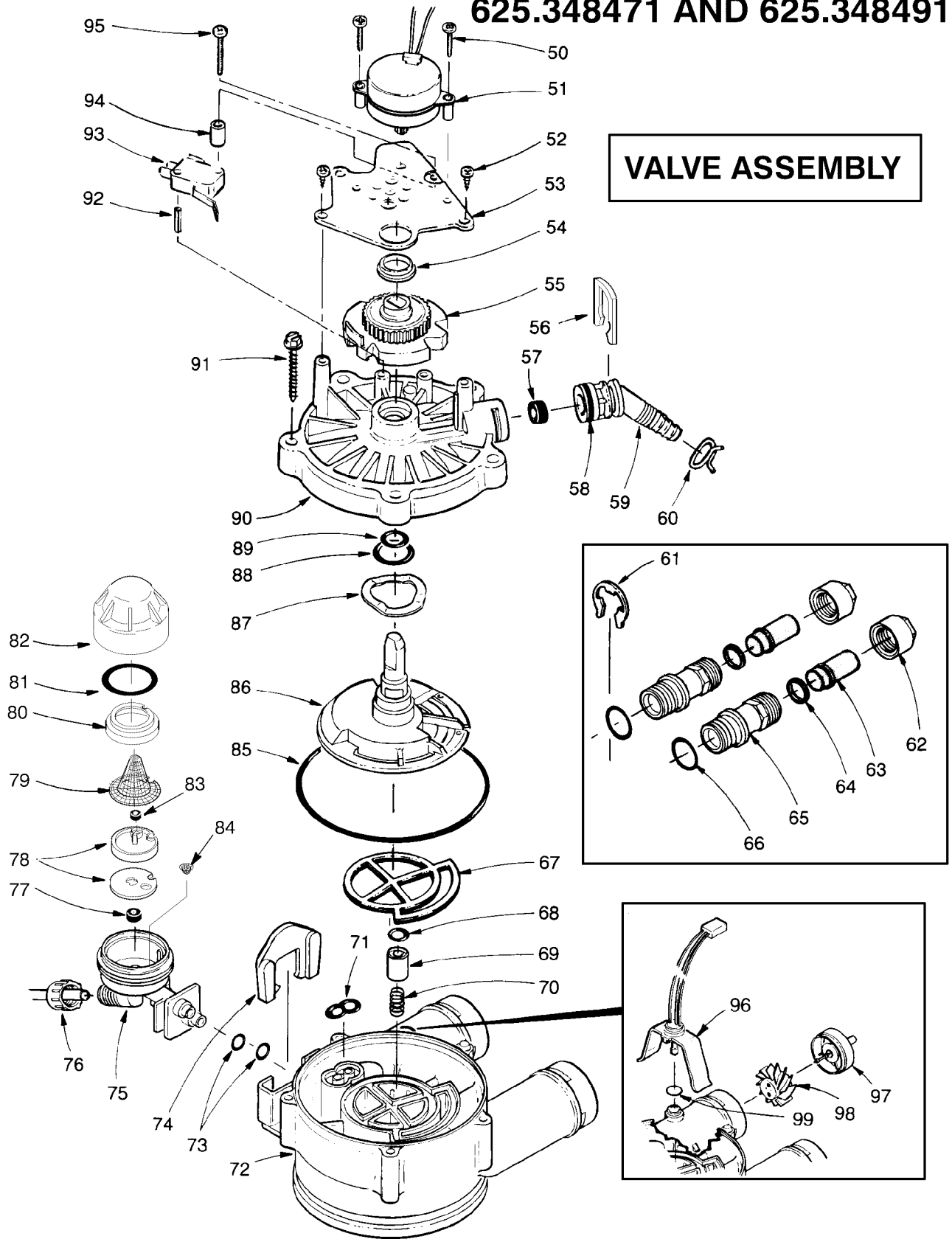

SEARS WATER SOFTENERS MODEL NOS. 625.348471 AND 625.348491 PARTS LIST

KEY NO.	PART NUMBER	DESCRIPTION
50	7131755	Screw, #6-20 x 7/8 (2 req.)
51	7133008	Motor (incl. 2 ea. of Key No. 50)
52	0900857	Screw, #6-20 x 3/8 (2 req.)
53	7117808	Motor Plate
54	0503288	Bearing
55	7113927	Cam and Gear
56	7142942	Clip (Drain)
57	0501228	Flow Plug
58	7170327	O-Ring, 5/8 x 13/16
59	7024160	Drain Hose Adaptor
60	0900431	Tubing Clamp ●▲
61	7116713	Clip (2 req.) ●▲
62	0507369	Installation Nut (2 req.) ▲
63	0507615	Installation Tube (2 req.) ▲
64	7170335	Washer (2 req.) ▲
◆	42-3441	Install. Kit (incl. Key Nos.62–64) ①
65	2207800	Installation Adaptor (2 req.) ●②
66	7170288	O-Ring, 15/16 x 1-3/16 (2 req.) ●②
67	7134224	Rotor Seal
68	7170204	O-Ring, 3/8 x 9/16
69	7092642	Plug (Drain Seal)
70	7129889	Spring
71	7081764	Seal (Nozzle & Venturi)
72	7082053	Valve Body
73	7170319	O-Ring, 1/4 x 3/8 (2 req.)
74	7081201	Retainer (Nozzle & Venturi)
75	7081104	Nozzle & Venturi Housing
76	1202600	Nut - Ferrule
77	1148800	Flow Plug, .3 gpm
78	7187772	Nozzle and Venturi — Gasket Kit
—	7163663	Gasket (only)

① PART OR ASSEMBLY INCLUDED WITH MODEL NO. 625.348491 ONLY.

② PARTS INCLUDED WITH MODEL NO. 625.348471 ONLY.

KEY NO.	PART NUMBER	DESCRIPTION
79	7146043	Screen
80	7167659	Screen Support
81	7170262	O-Ring, 1-1/8" x 1-3/8"
82	7081188	Cap
83	0521829	Flow Plug, .1 gpm
84	7095030	Cone Screen
85	7170246	O-Ring, 3-3/8 x 3-5/8
86	7199232	Rotor & Disc
87	7082087	Wave Washer
88	7170212	O-Ring, 3/4 x 15/16
89	7170238	O-Ring, 7/16 x 5/8
90	7085263	Valve Cover
91	7074123	Screw, #10-14 x 2 (5 req.)
92	7077472	Expansion Pin
93	7030713	Switch
94	7117816	Spacer
95	7070412	Screw, #4-24 x 1-1/8 (flat head)
96	7234414	Sensor Housing
97	2204101	Turbine Support and Shaft
98	7117858	Turbine
99	9000803	O-Ring
◆	7187065	Nozzle & Venturi Assy. (incl. Key Nos. 75, and 77 through 84)
◆	7147112	Parts Bag, Model No. 625.348471 (included parts marked with a ●, pages 28, 29 & 31) — order manuals separately, if needed.
◆	7144821	Parts Bag, Model No. 625.348491 (included parts marked with a ▲, pages 28, 29 & 31) — order manuals separately, if needed.
◆	7129716	Seal Kit (incl. Key Nos. 67, 68, 71, 85, 88 and 89)
◆	42-3433	Drain Tube, 3/8" I.D. x 20' ①

◆ not illustrated

BYPASS INSTALLATION VALVE MODEL NO. 625.34372

KEY NO.	PART NUMBER	DESCRIPTION
100	0502206	Retainer Ring
101	7129863	Bypass Body
102	7105013	O-Ring, 13/16 x 1 (4 req.)
103	7130911	Stem
104	7170288	O-Ring, 15/16 x 1-3/16 (2 req.)
◆	42-3437	Bypass Valve (Complete) ▲①

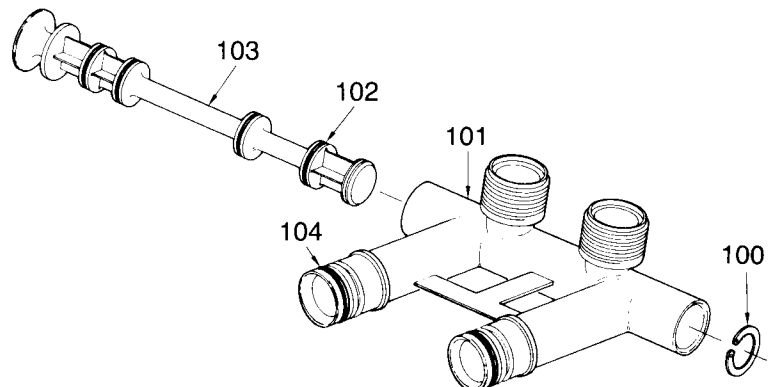

OWNER'S MANUAL

MODEL NOS.
625.348471
625.348491

The model number of your water softener is found on the rating decal. This decal is on the rim, under the salt cover.

When requesting service or ordering parts, always provide the following information:

- ◆ Product Type
- ◆ Model Number
- ◆ Part Number
- ◆ Part Description



Demand Water Softeners

For the repair or replacement parts you need
delivered directly to your home

Call 7 am - 7 pm, 7 days a week

1 - 800 - 366 - PART

(1 - 800 - 366 - 7278)

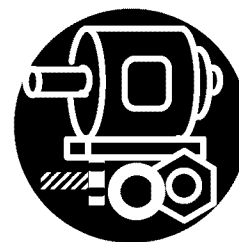

For in-home major brand repair service

Call 24 hours a day, 7 days a week

1 - 800 - 4 - REPAIR

(1 - 800 - 473 - 7247)



For the location of a
Sears Parts and Repair Center in your area

Call 24 hours a day, 7 days a week

1 - 800 - 488 - 1222



For information on purchasing a Sears
Maintenance Agreement, or to inquire
about an existing Agreement

Call 9 am - 5 pm, Monday - Saturday

1 - 800 - 827 - 6655



SEARS
REPAIR SERVICES

America's Repair Specialists

Sears, Roebuck and Co., Hoffman Estates, IL 60179 U.S.A.

7198985 (Rev. B 05/30/01)