

Use & Care Guide

Manual de Uso y Cuidado

English / Español

Models/Modelos: 790.46913

Kenmore Pro[®]

Electric Warmer Drawer

Cajón Calentador

P/N 318201033A (1411)

Sears Brands Management Corporation

Hoffman Estates, IL 60179 U.S.A.

www.kenmore.com

www.sears.com



Table of Contents

Warmer Drawer Warranty	2	Setting Warmer Drawer control	5-6
IMPORTANT SAFETY INSTRUCTIONS	3-4	General Care & Cleaning.....	7-8
Product Record	4	Before You Call.....	8
Serial Plate Location	4	Protection Agreements.....	9
Before setting Warmer Drawer Control	5	Sears Service.....	10
		Español.....	11

KENMORE PRO LIMITED WARRANTY

WITH PROOF OF SALE, the following warranty coverage applies when this appliance is correctly installed, operated and maintained according to all supplied instructions. To arrange for warranty service, call: 1-800-4-MY-HOME® (1-800-469-4663).

FOR ONE YEAR from the date of sale this appliance is warranted against defects in material or workmanship. A defective appliance will receive free repair or replacement at option of seller.

FOR TWO YEARS from the date of sale, a free replacement part will be supplied for a ceramic cooktop that fails due to thermal shock or for a ceramic cooktop heating element that is defective. After the first year from the sale date you are responsible for the labor cost of part installation.

All warranty coverage applies for only 90 DAYS from the sale date if this appliance is ever used for other than private household purposes.

This warranty covers ONLY defects in material and workmanship, and will NOT pay for:

1. Cracks in a ceramic glass cooktop that are not a result of thermal shock.
2. Stains and scratches on a ceramic glass cooktop resulting from accident or improper operation or maintenance.
3. Discoloration of cooktop surfaces resulting from normal use.
4. Expendable items that can wear out from normal use, including but not limited to filters, belts, bags or screw-in base light bulbs.
5. A service technician to clean or maintain this appliance, or to instruct the user in correct appliance installation, operation and maintenance.
6. Service calls to correct appliance installation not performed by Sears authorized service agents, or to repair problems with house fuses, circuit breakers, house wiring, and plumbing or gas supply systems resulting from such installation.
7. Damage to or failure of this appliance resulting from installation not performed by Sears authorized service agents, including installation that was not in accord with electrical, gas or plumbing codes.
8. Damage to or failure of this appliance, including discoloration or surface rust, if it is not correctly operated and maintained according to all supplied instructions.
9. Damage to or failure of this appliance, including discoloration or surface rust, resulting from accident, alteration, abuse, misuse or use for other than its intended purpose.
10. Damage to or failure of this appliance, including discoloration or surface rust, caused by the use of detergents, cleaners, chemicals or utensils other than those recommended in all instructions supplied with the product.
11. Damage to or failure of parts or systems resulting from unauthorized modifications made to this appliance.
12. Service to an appliance if the model and serial plate is missing, altered, or cannot easily be determined to have the appropriate certification logo.

Disclaimer of implied warranties; limitation of remedies

Customer's sole and exclusive remedy under this limited warranty shall be product repair or replacement as provided herein. Implied warranties, including warranties of merchantability or fitness for a particular purpose, are limited to one year on the appliance and two years on a ceramic cooktop and heating elements, or the shortest period allowed by law. Seller shall not be liable for incidental or consequential damages. Some states and provinces do not allow the exclusion or limitation of incidental or consequential damages, or limitation on the duration of implied warranties of merchantability or fitness, so these exclusions or limitations may not apply to you.

This warranty applies only while this appliance is used in the United States.

This warranty gives you specific legal rights, and you may also have other rights which vary from state to state.

Sears Brands Management Corporation, Hoffman Estates, IL 60179

IMPORTANT SAFETY INSTRUCTIONS

Read all instructions before using this appliance.

This manual contains important safety symbols and instructions. Please pay attention to these symbols and follow all instructions given.

⚠ WARNING This symbol will help alert you to situations that may cause serious bodily harm, death or property damage.

⚠ CAUTION This symbol will help alert you to situations that may cause bodily injury or property damage.

- Remove all tape and packaging before using the appliance. Destroy the carton and plastic bags after unpacking the appliance. Never allow children to play with packaging material.
- Proper Installation—Be sure your appliance is properly installed and grounded by a qualified technician in accordance with the National Electrical Code ANSI/NFPA No. 70—latest edition in the U.S. A., or CSA C22.1, Part 1 in Canada, and local code requirements. Install only per installation instructions provided in this manual.
Sears Parts & Repair is the recommended repair service for this appliance. Know how to disconnect the electrical power to the drawer at the circuit breaker or fuse box in case of an emergency.
- User Servicing—Do not repair or replace any part of the appliance unless specifically recommended in the manuals. All other servicing should be done only by a qualified technician to reduce the risk of personal injury and damage to the appliance.
- Never modify or alter the construction of a drawer by removing panels, wire covers, locking plates, or any other part of the product.

⚠ WARNING Stepping, leaning or sitting on the door or drawer can result in serious injuries and may also cause damage to the warmer drawer. Do not allow children to climb or play around the drawer. An open drawer, when hot, may cause burns.

⚠ WARNING Do not use the warmer drawer for storage.

- Storage in or on Appliance—Flammable materials should not be stored in the drawer. This includes paper, plastic and cloth items, such as cookbooks, plasticware and towels, as well as flammable liquids. Do not store explosives, such as aerosol cans, on or near the warmer drawer. Flammable materials may explode and result in fire or property damage.
- Do not leave children alone. Children should not be left alone or unattended in the area where an appliance is in use. They should never be allowed to sit or stand on any part of the appliance.
- **DO NOT TOUCH INTERIOR SURFACES OF THE WARMER DRAWER.** Surfaces may be hot even though they are dark in color. During and after use, do not touch, or let clothing or other flammable materials touch these areas until they have had sufficient time to cool.
- Wear Proper Apparel—Loose-fitting or hanging garments should never be worn while using the appliance. Do not let clothing or other flammable materials contact hot surfaces.
- Use Only Dry Potholders—Moist or damp potholders on hot surfaces may result in burns from steam. Do not let the potholders touch hot heating elements. Do not use a towel or other bulky cloth instead of a potholder.

⚠ WARNING Do Not Use Water or Flour on Grease Fires. Smother the fire with a pan lid, or use baking soda, a dry chemical or foam-type extinguisher.

- Do Not Heat Unopened Food Containers—Build-up of pressure may cause the container to burst and result in injury.

⚠ WARNING

- | | |
|---|--|
| <ul style="list-style-type: none">• All Warmer Drawers can tip.• Injury to persons could result.• Install anti-tip device packed with warmer drawer.• See Installation Instructions. | <p>To reduce the risk of tipping of the Warmer Drawer, the drawer must be secured by properly installed anti-tip locking provided with the drawer. To check if the locking plates are installed properly, grasp the handle of the open drawer and see if the drawer will slide out of the opening. Refer to the installation instructions for proper locking plate installation.</p> |
|---|--|

IMPORTANT SAFETY INSTRUCTIONS

- **IMPORTANT**—Do not attempt to operate the warmer drawer during a power failure. If the power fails, always turn the control off. If the drawer is not turned off and the power resumes, the drawer may begin to operate again. Food left unattended could spoil.

⚠ WARNING Never use your appliance for warming or heating the room.

IMPORTANT INSTRUCTIONS FOR USING YOUR WARMER DRAWER

- **Protective Liners**—Do not use aluminum foil to line warmer drawer. Any other use of protective liners or aluminum foil may result in poor performance or damage to the appliance. Only use aluminum foil as recommended for baking if used as a cover placed on the food.
- **Glazed Cooking Utensils**—Only certain types of glass, glass/ceramic, ceramic, earthenware, or other glazed utensils are suitable for use without breaking due to the sudden change in temperature. Check the manufacturer's recommendations.
- **Use Care When Opening Warmer Drawer**—Stand to the side of the unit when opening the door of a hot drawer. Let hot air or steam escape before you remove or replace food in the warmer drawer.
- **Placement of Warmer Drawer Racks**—Always place rack in desired location while drawer is cool. If rack must be moved while hot, use

extreme caution. Use potholders and grasp the rack with both hands to reposition. Do not let potholders contact the hot element or interior of the warmer drawer. Remove all utensils from the rack before removing rack.

IMPORTANT INSTRUCTIONS FOR CLEANING YOUR WARMER DRAWER

- **Clean the drawer regularly to keep all parts free of grease that could catch fire.** Do not allow grease to accumulate. Greasy deposits could catch fire.
- **Kitchen cleaners/aerosols**—Always follow the manufacturer's recommended directions for use. Be aware that excess residue from cleaners and aerosols may ignite causing damage and/or injury.
- **Do not cover the broiler grid or oven bottom with aluminum foil.** Exposed fat and grease could ignite.
- **Protective liners**—Do not use aluminum foil to line bottom. Only use aluminum foil as recommended in this manual. Improper installation of these liners may result in risk of electric shock, or fire.

IMPORTANT SAFETY NOTICE

The California Safe Drinking Water and Toxic Enforcement Act requires the Governor of California to publish a list of substances known to the state to cause cancer, birth defects or other reproductive harm, and requires businesses to warn customers of potential exposure to such substances.

SAVE THESE INSTRUCTIONS

Product Record

In this space below, record the date of purchase, model and serial number of your product. You will find the model and serial number printed on the serial plate.

Model No. 790

Serial No. _____

Date of purchase _____

Save these instructions and your sales receipt for future reference.

Please carefully read and save these instructions

This Use & Care Manual contains general operating instructions for your Warmer Drawer and feature information for several models. Your product may not have all the described features. The graphics shown are representative. The graphics on your appliance may not look exactly like those shown. Common sense and caution must be practiced when installing, operating and maintaining any appliance.

Serial Plate Location

You will find the model and serial number printed on the serial plate. The serial plate is located along the interior right side trim and visible when the warmer drawer is opened.

Remember to record the serial number for future reference.

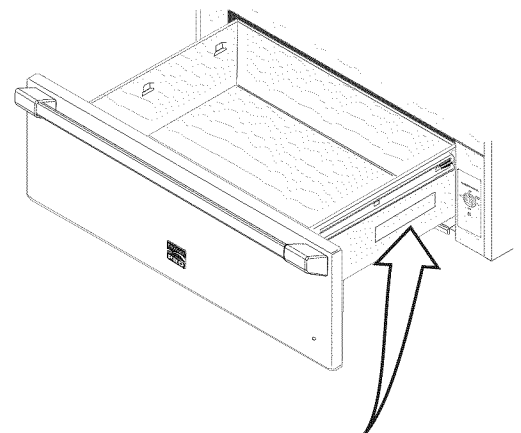

Serial Plate Location

Before Setting Warmer Drawer Control

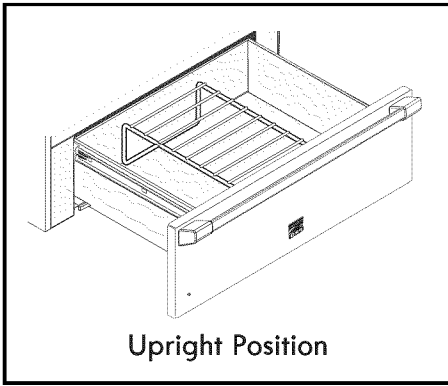

Arranging Warmer Drawer Rack Positions

Set the warmer drawer rack in the vertical position as shown below.

The rack can be used in 2 ways:

- In the **upright position** to allow low profile food items to be placed both under and on top of the rack (for example, rolls or biscuits on top of the rack and a casserole dish under).
- In the **downward position** for placement of light weight food items and empty dishware (for example, rolls or pastries and dinner plates).

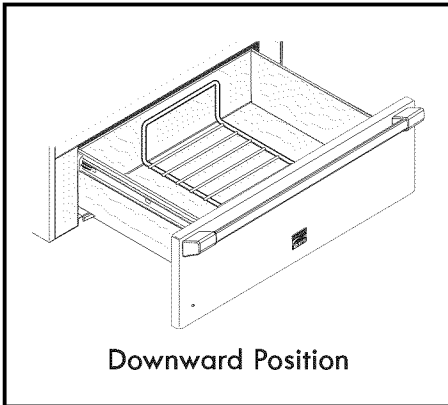

Setting Warmer Drawer Control

To Operate the Warmer Drawer

The purpose of the warmer drawer is to keep hot cooked foods at serving temperature. Always start with hot food. It is not recommended to heat cold food in the warmer drawer.

All food placed in the warmer drawer should be covered with a lid or aluminum foil to maintain moisture and softness. Do not cover crisp foods. **Do not use plastic wrap to cover food. Plastic may melt onto the drawer and be very difficult to clean.**

Use only dishware, utensils and cookware recommended for oven use in the warmer drawer.

Always use potholders or oven mitts when removing food from the warmer drawer as cookware and plates will be hot.

Indicator Light

The indicator light is located below the thermostat control knob. It turns on when the control is set, and stays on until the control is turned off. Make sure indicator light is off when removing food from drawer.

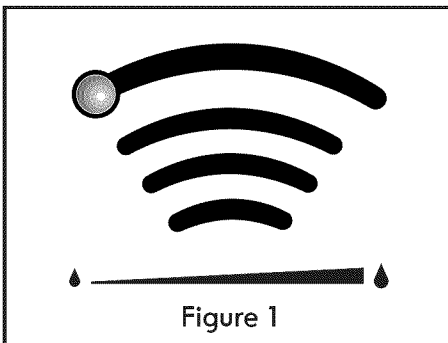

Warmer Drawer Humidity Controller Feature

This feature may be used to control humidity in the Warmer Drawer. The control knob is located on the inner front panel of the Warmer Drawer.

For dry heat: Slide the humidity control knob in the direction of less moist (Figure 1). This allows more of the moist heat to escape and provides a dryer environment for the food in the Warmer Drawer.

For moist heat: Slide the humidity control knob in the direction of more moist (Figure 2). This will help keep the food in the Warmer Drawer from drying out. Both heat and moisture will be applied to the Warmer Drawer cavity.

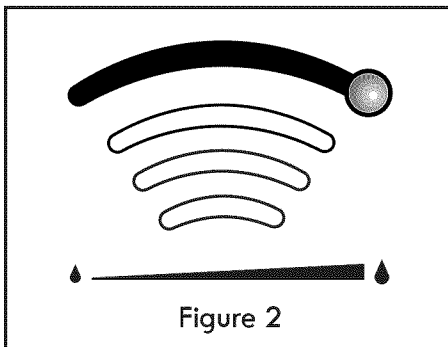

Note: For some types of servings you may want to store previously prepared food in a "dry heat" environment. For frequent controller adjustments, slide the control knob to any desired position.

Setting Warmer Drawer Control

Use the warmer drawer to keep hot foods hot such as: vegetables, gravies, meats, casseroles, biscuits and rolls, pastries and heated dinner plates.

The warmer drawer is equipped with a catch which may require a small amount of force when opening and closing the drawer.

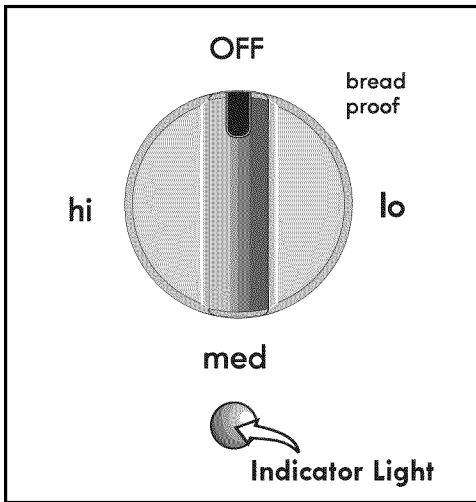

Warmer Drawer Recommended Food Settings Chart

Food Item	Setting
Bacon	Hi
Biscuits	Med
Casseroles	Med
Eggs	Med
Empty Dinner Plates	Lo
Fish, Seafood	Med
Fried Foods	Hi
Gravies, creams, sauces	Med
Ham	Med
Hamburger Patties	Hi
Pancakes, Waffles	Hi
Pastries	Med
Pies	Med
Pizza	Hi
Pork Chops	Hi
Potatoes (baked)	Hi
Potatoes (mashed)	Med
Poultry	Hi
Roasts (Beef, Pork, Lamb)	Med
Rolls, soft	Lo
Rolls, hard	Med
Vegetables	Med

To Set the Temperature Control

The Temperature Control is located on the inside right panel of the warmer drawer. The temperature range is from 80°F to 210°F, and the temperature settings are approximate from LO to HI throughout the range. Set the control to LO, MED, HI or anywhere in between.

1. To set the temperature, push in and turn the control to the desired setting.
2. For best results, preheat the drawer before adding food. An empty drawer will reach the LO setting in about 12 minutes, the MED setting in about 15 minutes, and the HI setting in about 18 minutes.
3. When done warming, turn the temperature control to OFF.

Temperature Selection

Refer to the chart in the side column for recommended settings. If a particular food is not listed, start with the medium setting. If more crispness is desired, remove the lid or aluminum foil from the food. Most foods can be kept at serving temperatures by using the medium setting. When a combination of foods are to be kept warm (for instance, a meat with 2 vegetables and rolls), use the high setting.

Refrain from opening the warmer drawer while in use to eliminate loss of heat from the drawer. Open only for adding or removing food.

To Warm Serving Bowls and Plates

Heat bowls and plates on the LO setting. Place empty dishes on the rack to raise them off drawer bottom. To further heat dishes or to heat fine china, check with the manufacturer for maximum heat tolerance.

Auto-Shutdown

This unit is programmed to automatically shutdown after 4 hours it is left on. The element will stop warming the drawer, the indicator light will turn off and a beep will sound each 20 seconds until the control knob is turned to "OFF" position.

Preparing Bread Dough for the Warmer Drawer

The Warmer Drawer has a Bread Proof feature that can be used to help prepare bread dough. The recommended length of time to keep bread dough in the Warmer Drawer is about 45-60 minutes. Be sure however to follow the recipe's recommended times.

The unrisen bread dough should be placed in a large bowl since the dough will nearly double in volume. Place the Warmer Drawer Rack in the downward position. Before placing in the Warmer Drawer, cover the bowl with a moist cloth or use wax paper that has been coated with a non-stick type cooking spray.

NOTE: The bread proof function uses low warming temperature which may be lower than your room temperature. The drawer will not work as a cooling device and will not be able to lower the temperature of foods to less than room temperature.

General Cleaning

Cleaning Various Parts of Your Appliance

Before cleaning any part of the warmer drawer, be sure all controls are turned OFF and the warmer drawer is COOL. REMOVE SPILLOVERS AND HEAVY SOILING AS SOON AS POSSIBLE. REGULAR CLEANINGS NOW WILL REDUCE THE EXTENT AND DIFFICULTY OF MAJOR CLEANING LATER.

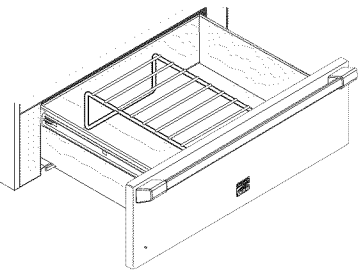
Surface	How to Clean
Glass Drawer Front Panel	You may use a glass cleaner on the outside glass of the drawer. DO NOT immerse the drawer in water. DO NOT spray or allow water or the glass cleaner to enter behind the drawer glass panel. DO NOT use oven cleaners, cleaning powders or any harsh abrasive cleaning materials on the outside of the drawer.
Plastic Control Knobs	To remove control knob, turn to the OFF position; grasp firmly and pull straight off the shaft. Clean with a cloth soaked in soapy water. Rinse with a clean water and a dishcloth. To replace knob after cleaning, line up the flat sides of both the knob and the shaft; then push the knob into place. Note: Humidity controller knob cannot be removed.
Stainless Steel	Clean stainless steel with hot, soapy water and a dishcloth. Rinse with clean water and a cloth. Do not use cleaners with high concentrations of chlorides or chlorines. Do not use harsh scrubbing cleaners. Only use kitchen cleaners that are especially made for cleaning stainless steel. Always be sure to rinse the cleaners from the surface as bluish stains may occur during heating that cannot be removed.
Porcelain Enamel Body Parts and Drawer Cavity	Gentle scouring with a soapy scouring pad will remove most spots. Rinse with a 1:1 solution of clear water and ammonia. If necessary, cover difficult spots with an ammonia-soaked paper towel for 30 to 40 minutes. Rinse with clean water and a damp cloth, and then scrub with a soap-filled scouring pad. Rinse and wipe dry with a clean cloth. Remove all cleaners or the porcelain may become damaged during future heating. DO NOT use spray oven cleaners.
Warmer Drawer Rack 	The rack may be removed for cleaning. If removed, clean by using a mild, abrasive cleaner following manufacturer's instructions. Rinse with clean water and dry.

General Cleaning (continued)

⚠ WARNING Turn the warmer drawer control knob to OFF before removing the drawer. **DO NOT** touch the warmer drawer element. The element may still be hot enough to cause burns, even if it is dark in color.

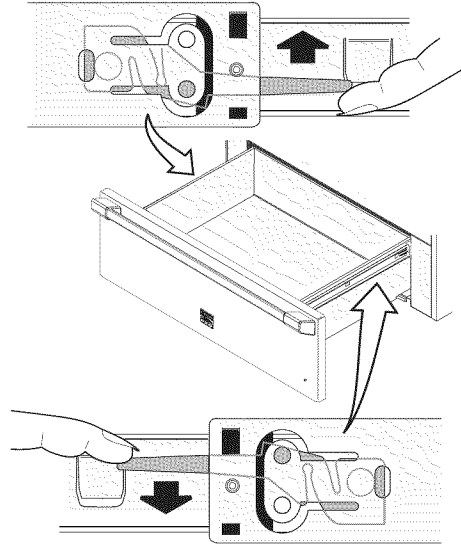

Warmer Drawer

To Remove and Replace Warmer Drawer

To Remove Warmer Drawer:

1. **⚠ WARNING** Turn power off before removing the warmer drawer.
2. Open the drawer to the fully opened position.
3. Locate the latches on both sides of the warmer drawer.
4. Pull up on the left glide latch and push down on the right glide latch.
5. Pull the drawer away from the appliance.
6. To clean warmer drawer, gently scour with a soapy scouring pad; this will remove most spots. Rinse with a 1:1 solution of clear water and ammonia. If necessary, cover difficult spots with an ammonia-soaked paper towel for 30 to 40 minutes. Rinse with clean water and a damp cloth. Remove all cleaners or the porcelain may become damaged during future heating. **DO NOT** use spray oven cleaners on the cooktop.

To Replace Warmer Drawer:

1. Align the glide latches on both sides of the drawer with the slots on the drawer.
2. Push the drawer back into the appliance.



⚠ WARNING Electrical Shock Hazard can occur and result in serious injury or death. Disconnect appliance from electric power before cleaning and servicing the warmer drawer.

Avoid Service Checklist

Before you call for service, review this list. It may save you time and expense. The list includes common occurrences that are not the result of defective workmanship or materials in this appliance.

OCCURRENCE	POSSIBLE CAUSE/SOLUTION
Drawer is not level.	Poor installation. Place a level on the cutout bottom. Make sure bottom is level. Be sure cutout bottom is strong and stable enough to adequately support drawer (and wall oven, if applicable).
Cannot move appliance easily. Appliance must be accessible for service.	Cabinets not square or are built in too tightly. Contact builder or installer to make appliance accessible.
Warmer drawer does not operate.	Make sure cord/plug is plugged tightly into outlet. Service wiring is not complete. Contact Sears or another qualified servicer. Power outage. Check house lights to be sure. Call your local electric company for service. An error at power up (or after a power failure) could happen if the control knob was left on the ON position. If a power failure should occur, be sure to set the control knob to the OFF position. This will reset the electronic controls. Once the control knob has been set to the OFF position, the electronic controls should return to normal operation.

MASTER PROTECTION AGREEMENTS

Congratulations on making a smart purchase. Your new Kenmore® product is designed and manufactured for years of dependable operation. But like all products, it may require preventive maintenance or repair from time to time. That's when having a Master Protection Agreement can save you money and aggravation.

The Master Protection Agreement also helps extend the life of your new product. Here's what the Agreement* includes:

- ☑ **Parts and labor** needed to help keep products operating properly **under normal use**, not just defects. Our coverage goes **well beyond the product warranty**. No deductibles, no functional failure excluded from coverage – **real protection**.
- ☑ **Expert service** by a force of more than **10,000 authorized Sears service technicians**, which means someone you can trust will be working on your product.
- ☑ **Unlimited service calls and nationwide service**, as often as you want us, whenever you want us.
- ☑ **«No-lemon» guarantee** – replacement of your covered product if four or more product failures occur within twelve months.
- ☑ **Product replacement** if your covered product can't be fixed.
- ☑ **Annual Preventive Maintenance Check** at your request – no extra charge.
- ☑ **Fast help by phone** – we call it **Rapid Resolution** – phone support from a Sears representative on all products. Think of us as a «talking owner's manual».
- ☑ **Power surge protection** against electrical damage due to power fluctuations.
- ☑ **\$250 Food Loss Protection** annually for any food spoilage that is the result of mechanical failure of any covered refrigerator or freezer.
- ☑ **Rental reimbursement** if repair of your covered product takes longer than promised.
- ☑ **25% discount** off the regular price of any non-covered repair service and related installed parts.

Once you purchase the Agreement, a simple phone call is all that it takes for you to schedule service. You can call anytime day or night, or schedule a service appointment online.

The Master Protection Agreement is a risk free purchase. If you cancel for any reason during the product warranty period, we will provide a full refund. Or, a prorated refund anytime after the product warranty period expires. Purchase your Master Protection Agreement today!

Some limitations and exclusions apply. For prices and additional information in the U.S.A. call 1-800-827-6655.

*** Coverage in Canada varies on some items. For full details call Sears Canada at 1-800-361-6665.**

Sears Installation Service

For Sears professional installation of home appliances, garage door openers, water heaters, and other major home items, in the U.S.A. or Canada call **1-800-4-MY-HOME®**.

Get it fixed, at your home or ours!

Your Home

For troubleshooting, product manuals and expert advice:



www.managemylife.com

For repair – **in your home** – of **all** major brand appliances, lawn and garden equipment, or heating and cooling systems, **no matter who made it, no matter who sold it!**

For the replacement parts, accessories and owner's manuals that you need to do-it-yourself.

For Sears professional installation of home appliances and items like garage door openers and water heaters.

1-800-4-MY-HOME[®] (1-800-469-4663)

Call anytime, day or night (U.S.A. and Canada)

www.sears.com www.sears.ca

Our Home

For repair of "carry-ins" like handheld lawn equipment or home electronics items, call anytime for the location of your nearest

Sears Parts & Repair Service Center

1-800-488-1222 (U.S.A.) **1-800-469-4663** (Canada)
www.sears.com www.sears.ca

To purchase a protection agreement on a product serviced by Sears:

1-800-827-6655 (U.S.A.) **1-800-361-6665** (Canada)

Para pedir servicio de reparación a domicilio, y para ordenar piezas:

1-888-SU-HOGAR[®]
(1-888-784-6427)
www.sears.com

Au Canada pour service en français:

1-800-LE-FOYER^{MC}
(1-800-533-6937)
www.sears.ca

The Sears logo, featuring the word "sears" in a lowercase, serif font with a textured, slightly distressed appearance.