

Bissell®

BigGreen Commercial™

BG10™

USER'S GUIDE

10N2 SERIES

- 2 Thank You
- 3 Safety Instructions
- 4 Product View
- 4 Assembly
- 5-6 Operations
- 6-8 Maintenance and Care
- 9 Troubleshooting
- 10 Replacement Parts
- 10 Accessories
- 11 Warranty
- 12 Customer Service

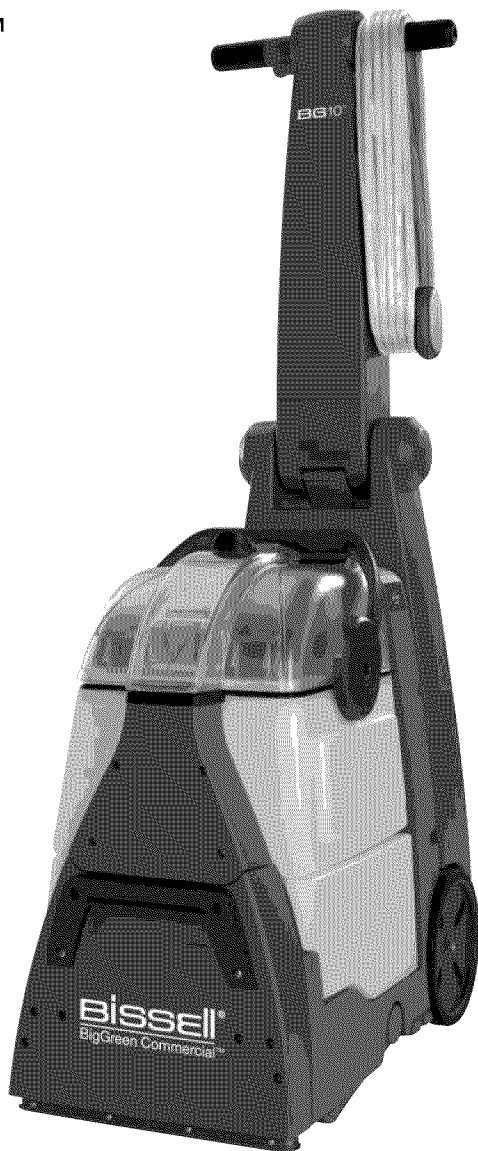

Thanks for buying a BISSELL Commercial Deep Cleaner

Thanks for buying a BISSELL Commercial Deep Cleaner-BG10. We're glad you purchased a BISSELL Commercial Deep Cleaner BG10. Everything we know about floor care went into the design and construction of this complete, high-tech commercial cleaning system.

Your BISSELL Commercial Deep Cleaner-BG10 is well made, and we back it with a limited one year warranty. We also stand behind it with a knowledgeable, dedicated Customer Service department, so, should you ever have a problem, you'll receive fast, considerate assistance.

My great-grandfather invented the floor sweeper in 1876. Today, BISSELL is a global leader in the design, manufacture, and service of high quality commercial products like your Commercial Deep Cleaner-BG10.

Thanks again, from all of us at BISSELL.

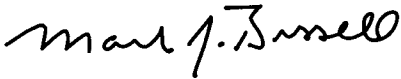
A handwritten signature in black ink that reads "Mark J. Bissell". The signature is written in a cursive, flowing style.

**Mark J. Bissell
Chairman, President & CEO**

IMPORTANT SAFETY INSTRUCTIONS

When using an electrical appliance, basic precautions should be observed, including the following:

READ ALL INSTRUCTIONS BEFORE USING YOUR COMMERCIAL DEEP CLEANER-BG10.

⚠ WARNING: To reduce the risk of fire, electric shock, or injury:

- Do not immerse.
- Use only on surfaces moistened by cleaning process.
- Always connect to a properly grounded outlet.
- See Grounding Instructions.
- Unplug from outlet when not in use and before conducting maintenance or troubleshooting.
- Do not leave machine when it is plugged in.
- Do not service machine when it is plugged in.
- Do not use with damaged cord or plug.
- If appliance is not working as it should, has been dropped, damaged, left outdoors, or dropped into water, have it repaired at an authorized Service Center.
- Use indoors only.
- Do not pull or carry by cord, use cord as a handle, close door on cord, pull cord around sharp corners or edges, run appliance over cord, or expose cord to heated surfaces.
- Unplug by grasping the plug, not the cord.
- Do not handle plug or appliance with wet hands.
- Do not put any object into appliance openings, use with blocked opening, or restrict air flow.
- Do not expose hair, loose clothing, fingers or body parts to openings or moving parts.
- Do not pick up hot or burning objects.
- Do not pick up flammable or combustible materials (lighter fluid, gasoline, kerosene, etc.) or use in the presence of explosive liquids or vapor.
- Do not use appliance in an enclosed space filled with vapors given off by oil base paint, paint thinner, some moth proofing substances, flammable dust, or other explosive or toxic vapors.
- Do not pick up toxic material (chlorine bleach, ammonia, drain cleaner, gasoline, etc.).
- Do not modify the 3-prong grounded plug.
- Do not allow to be used as a toy.
- Do not use for any purpose other than described in this user's guide.
- Do not unplug by pulling on the cord.
- Use only manufacturer's recommended attachments.
- Always install float before any wet pick up operation.
- Use only cleaning products formulated by BISSELL for use in this appliance to prevent internal component damage. See the cleaning fluid section of this guide.
- Keep openings free of dust, lint, hair, etc.
- Do not point attachment nozzle at people or animals
- Keep appliance on a level surface.

- Do not use without intake screen filter in place.
- Turn off all controls before unplugging.
- Unplug before attaching the TurboBrush®.
- Be extra careful when cleaning stairs.
- Close attention is necessary when used by or near children.

SAVE THESE INSTRUCTIONS.

THIS MODEL IS FOR COMMERCIAL USE.

GROUNDING INSTRUCTIONS

This appliance must be connected to a grounded wiring system. If it should malfunction or break down, grounding provides a safe path of least resistance for electrical current, reducing the risk of electrical shock. The cord for this appliance has an equipment-grounding conductor and a grounding plug. It must only be plugged into an outlet that is properly installed and grounded in accordance with all local codes and ordinances.

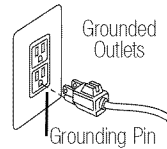

⚠ WARNING:

Improper connection of the equipment-grounding conductor can result in a risk of electrical shock. Check with a qualified electrician or service person if you aren't sure if the outlet is properly grounded. **DO NOT MODIFY THE PLUG.** If it will not fit the outlet, have a proper outlet installed by a qualified electrician. This appliance is designed for use on a nominal 120-volt circuit, and has a grounding attachment plug that looks like the plug in the drawing above. Make certain that the appliance is connected to an outlet having the same configuration as the plug. No plug adapter should be used with this appliance.

Product view

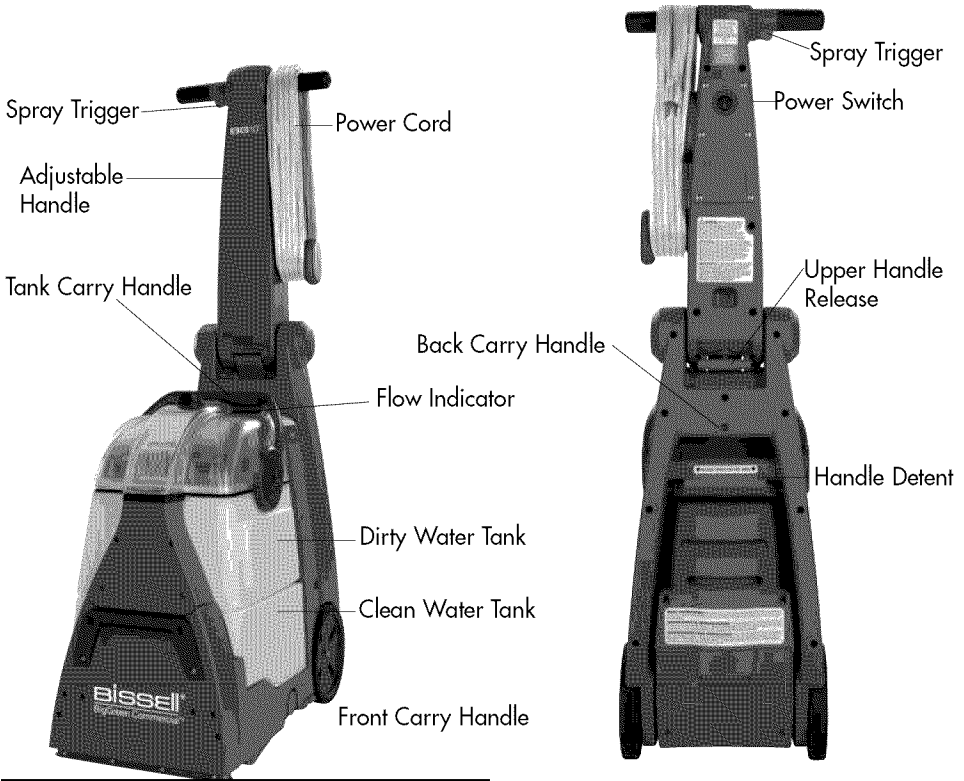

WARNING: To reduce the risk of fire and electric shock due to internal component damage, use only BISSELL cleaning fluids intended for use with the deep cleaner. Non-BISSELL cleaning solutions may harm the machine and void the warranty.

Cleaning fluid

Keep plenty of genuine BISSELL BigGreen Complete™ Formula on hand so you can clean and protect whenever it fits your schedule. Always use genuine BISSELL deep cleaning formulas. Non-BISSELL cleaning solutions may harm the machine and will void the warranty.

BISSELL BigGreenComplete™ Formula.



Assembly

Your BISSELL Commercial Deep Cleaner-BG10 comes with no assembly required!

Operations

Before you clean

1. Move furniture to another area if cleaning the entire room (optional.)
2. Vacuum area with a dry vacuum cleaner thoroughly before deep cleaning.
3. Plan your cleaning route to leave an exit path. It is best to begin cleaning in the corner farthest from your exit.

Carpet cleaning

1. Remove dirty water tank. Pull dirty water tank handle to upright position and lift up to remove dirty water tank.
2. Lift clean water tank from the base of machine.
 - A. Unscrew cap on top of the clean water tank. Fill tank to **FILL** line with clean, hot tap water.
 - B. Measure BISSELL formula using cap on tank. Fill cap to line twice for each full tank of water. Always use genuine BISSELL formulas to maximize cleaning and for the safety of your machine
 - C. Screw cap back onto clean water tank and place tank onto base of the machine.
3. Replace dirty water tank securely on top of the clean water tank and push handle back to lock into place.
4. Plug into a proper outlet and turn the power switch to the ON (I) position.
5. Detent handle by pushing down on the green lever on the back of the machine while pulling back.
6. **Cleaning strokes.** While pressing the trigger, make one slow forward wet pass and another back. Let the formula and DirtLifter PowerBrushes do the work for you.

Note: Your machine is equipped with a circuit breaker that will automatically shut off the brush if a large or loose object is caught in the brush roll. If that happens, be sure to unplug your machine, remove the foreign object and then plug machine in to reset the circuit breaker.

ATTENTION:
Some Berber carpets have a tendency to fuzz with wear. Repeated strokes in the same area with an ordinary vacuum or deep cleaner may aggravate this condition.

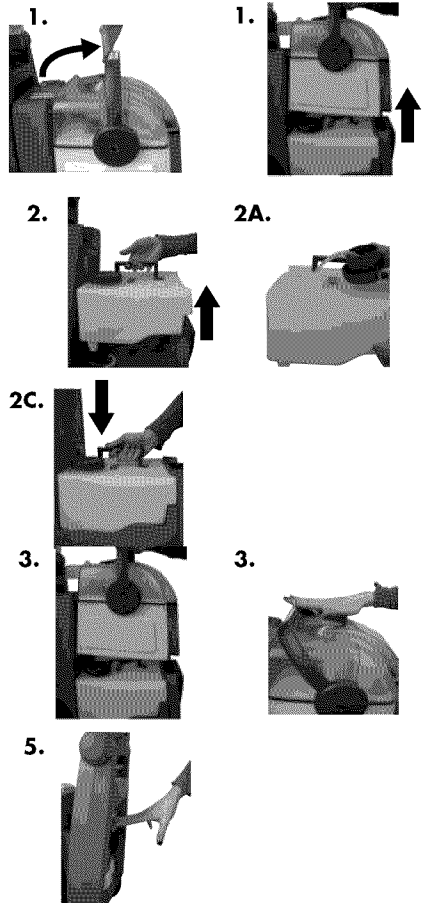

Operations

Carpet cleaning continued

7. **Cleaning strokes.** Release the trigger and make one slow forward and backward pass over the same area to remove any residual dirty water and aid in drying. Repeat cleaning passes until solution being pulled up appears clean. Continue passes without pressing the trigger until you can't see any more water being pulled up.
8. Remove the dirty water tank by pulling the handle to the upright position and lift up. Carry the tank like a bucket to a utility sink or outside where you will dispose of the dirty water.
9. Unlatch the top of the tank from the bottom by pushing the handle all the way forward and lifting the top off. Pour dirty water into the sink.
Note: You may notice hair and debris deposits on the carpet or in the tank that were loosened by the cleaning action (especially with newer carpets that have never been deep cleaned before). This debris should be picked up and thrown away.
10. Fill the clean water tank with clean hot tap water and follow instructions 2 - 7 to continue cleaning.

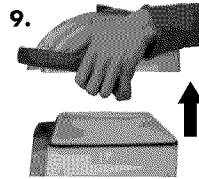
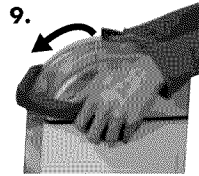
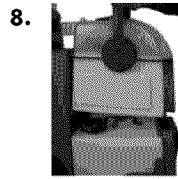

CAUTION:

Do not overwet. Take care not to run over loose objects or edges of area rugs. Stalling brush may result in premature belt failure.

Maintenance and care

Machine storage

Once your cleaning is complete, make sure both the dirty and clean water tanks are emptied, rinsed out and dried before the next use.

Note: Store cleaner in a protected, dry area. Since this product uses water, it must not be stored where there is a danger of freezing. Freezing will damage internal components and void the warranty.

Maintenance and care

Machine care

For best results, a few simple steps can assure your machine is well maintained after your cleaning is complete

1. Turn power OFF (0). Unplug the machine and wrap the power cord.
2. After emptying the clean and dirty water tanks, rinse them out with running hot tap water.
3. The top half of the dirty water tank can also be rinsed clean through the nozzle area.
4. After carpet is dry, vacuum again to remove hair and fuzz.



WARNING:

To reduce the risk of fire, electric shock, or injury, turn power OFF and disconnect plug from electrical outlet before performing maintenance or troubleshooting.

Belt removal and replacement

1. Turn off the machine and unplug it from the outlet.
2. Remove the dirty and clean water tanks from the base of the machine.
3. While standing behind the unit, lay the unit on its' side (cord side up)
4. Looking at the bottom of unit, find the back center of the brush carriage where the carriage latch is located. It is between the brush assembly and the front wheels.
5. Pull brush carriage towards you with one hand until it stops, then pinch the carriage latch with other hand while pulling the carriage towards you. The carriage should swing out to access belt cover.
6. Remove three screws from cover. Lift and remove to access brush carriage.
7. Turn the belt inward towards the large pulley while lifting out.
8. Place new belt over small pulley first and then slip the belt over the large pulley.
9. Replace the brush carriage and screws.
10. Push brush carriage back into place making sure the carriage latch locks back into place.

3.

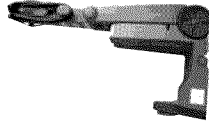

4.

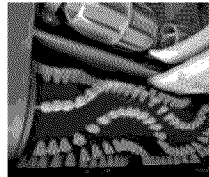

5.



6A.

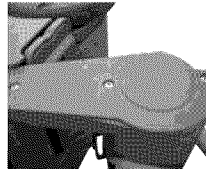

6B.



7.

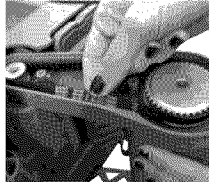

8.



9.

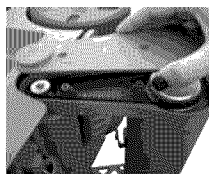

10.

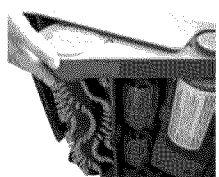

Maintenance and care

Brush removal and replacement

1. Turn OFF (O) the machine and unplug from the outlet.
2. Remove the dirty and clean water tanks from the base of the machine.
3. While standing behind the unit, lay the unit on its' side (cord side down).
4. Looking at the bottom of the unit, find the center of the brush carriage where the carriage latch is located. It is between the brush assembly and wheels.
5. Pull the brush carriage towards you with one hand until it stops. Pinch the carriage latch with the other hand while pulling the carriage towards you. The carriage should swing out to access brush end cover.
6. Remove three screws from endcap. Pull endcap off to release brush roll.
7. With cover removed, the brush comes out easily by tilting the loose end out of the carriage.
8. To replace the brush roll back into the unit, place the large open end of the brush onto the carriage and tilt opposite end back into place. (same image as 7, just change arrow direction)
9. With the brush sitting relatively straight up and down by itself, place endcap back on top and replace three screws.
10. Spin the brush by hand to make sure it turns freely with some minor resistance from the motor. Push brush carriage back into place with a light pull against the lock.

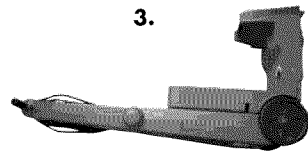

4.



5.

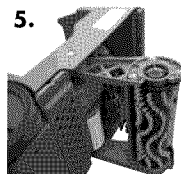

6A.

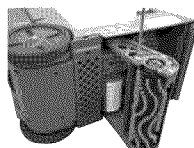

6B.

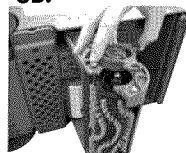

7.



8.



9.

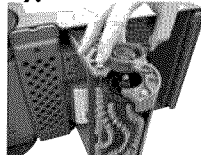

10B.



Troubleshooting



WARNING:

To reduce the risk of fire, electric shock, or injury, turn power OFF and disconnect plug from electrical outlet before performing maintenance or troubleshooting.

Reduce Spray or No Spray

Possible causes

1. Water tank may be empty
2. Tank may not be seated completely
3. Pump may have lost prime.
4. Debris filter on base is clogged

DirtLifter® PowerBrush does not turn

Possible causes

1. The belt is off or broken
2. The unit is in the upright position
3. Circuit breaker on machine may have tripped

Cleaner not picking up solution

Possible causes

1. Tanks may not be seated properly
2. Clean water tank is empty
3. Dirty water tank has picked up the maximum amount of dirty water the red float door has closed
4. Red float "door" in the tank may have closed as a result of bumping an object or moving machine back and forth too quickly
5. Front nozzle of machine is clogged
6. Upper body filter is clogged

Other maintenance or service not included in the manual should be performed by an authorized service representative.

Thank you for selecting a BISSELL product.

Please do not return this product to the store.

For any questions or concerns, BISSELL is happy to be of service. Contact us directly at 1-855-544-7336.

Remedies

1. Fill clean tank with hot tap water
2. Turn power OFF (0). Remove and reseat tank.
3. Turn power OFF (0) and then back ON (1). Wait one minute, then depress trigger
4. Use hand to remove debris

Remedies

1. Turn power OFF (0) and unplug unit from outlet. Follow instructions on page 14
2. Brushes only rotate when unit is reclined using the detent pedal
3. Turn the machine OFF (0) and unplug from outlet. Check to see if foreign object is caught in brush roll. Remove object. Plug machine in to reset circuit breaker

Remedies

1. Pick up both the clean and dirty water tanks and reseat them so they fit snugly on the unit
2. Check fluid levels in clean water tank and refill if necessary
3. Empty dirty water tank. Refill clean water tank with water and formula. Place both tanks back onto unit
4. Turn the machine OFF(0), allowing red float door to release into the open position,. Turn the unit back ON (1) to continue cleaning. Be sure your forward and backward strokes are completed at a slower pace
5. Use fingers to remove any debris from this area
6. Use fingers to remove any debris from this area

Replacement parts -

Item	Part No.	Part Name
1	203-7451	Float
2	203-7452	Dirty tank assembly
3	203-7453	Dirty tank gasket
4	203-7454	Clean tank assembly
5	203-7455	Clean tank cap assembly
6	203-7456	Nozzle gasket
7	203-7741	Nozzle assembly
8	203-7458	Brush
9	203-7459	Brush endcap
10	203-7460	Belt

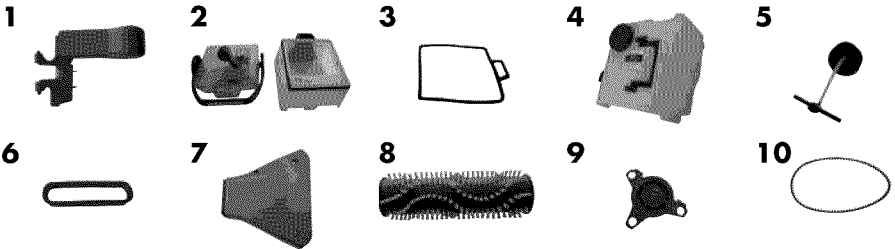

Accessories

Item	Part No.	Part Name
1	203-6651	3" Tough Stain Tool
2	203-6652	Powered TurboBrush® Hand Tool
3	203-6653	4" Upholstery Tool
4	203-6654	6" Stair Tool
5	203-6655	Spraying Crevice Tool
6	203-0116	2-in-1 Crevice Tool
7	203-7240	Tough Stain Tool
8	30G3	Hose assembly, 6" tool, bag
9	31B6	BISSELL BigGreen Complete™ Formula

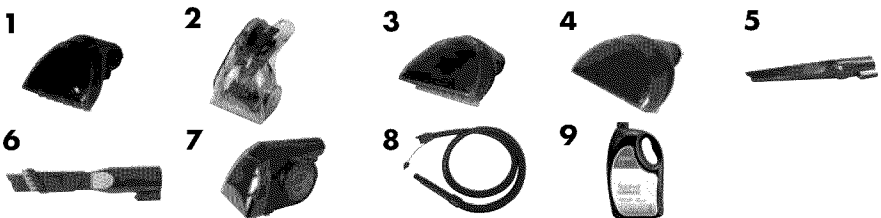

For a complete list of replacement parts and cleaning formulas, for your BISSELL Commercial deep cleaner please visit www.bissellcommercial.com or contact BISSELL Customer Service at 1.855.544.7336.

Warranty - BISSELL Commercial Deep Cleaner-BG10

This warranty gives you specific legal rights, and you may also have other rights which may vary from state to state. If you need additional instruction regarding this warranty or have questions regarding what it may cover, please contact BISSELL Customer Service by E-mail, telephone, or regular mail as described below.

Limited one Year Warranty

Subject to the *EXCEPTIONS AND EXCLUSIONS identified below, upon receipt of the product BISSELL Homecare, Inc. will repair or replace (with new or remanufactured components or products), at BISSELL's option, free of charge from the date of purchase by the original purchaser, for one year any defective or malfunctioning part.

See information below on "If your BISSELL product should require service".

This warranty does not apply to fans or routine maintenance components such as filters, belts, or brushes. Damage or malfunction caused by negligence, abuse, neglect, unauthorized repair, or any other use not in accordance with the user's guide is not covered.

If your BISSELL product should require service:

Contact BISSELL Customer Service to locate a BISSELL Authorized Service Center in your area.

If you need information about repairs or replacement parts, or if you have questions about your warranty, contact BISSELL Customer Service.

Website

www.bissellcommercial.com

Or Call:

BISSELL Customer Service

1-855-544-7336

Monday - Friday 8 a.m. - 5 p.m. ET

Or Write:

BISSELL Business Ventures, LLC.

PO Box 3606

Grand Rapids, MI 49501

ATTN: Customer Service

BISSELL BUSINESS VENTURES, LLC. IS NOT LIABLE FOR INCIDENTAL OR CONSEQUENTIAL DAMAGES OF ANY NATURE ASSOCIATED WITH THE USE OF THIS PRODUCT. BISSELL'S LIABILITY WILL NOT EXCEED THE PURCHASE PRICE OF THE PRODUCT.

Some states do not allow the exclusion or limitation of incidental or consequential damages, so the above limitation or exclusion may not apply to you.

*EXCEPTIONS AND EXCLUSIONS FROM THE TERMS OF THE LIMITED WARRANTY

THIS WARRANTY IS EXCLUSIVE AND IN LIEU OF ANY OTHER WARRANTIES EITHER ORAL OR WRITTEN. ANY IMPLIED WARRANTIES WHICH MAY ARISE BY OPERATION OF LAW, INCLUDING THE IMPLIED WARRANTIES OF MERCHANTABILITY AND FITNESS FOR A PARTICULAR PURPOSE, ARE LIMITED TO THE ONE YEAR DURATION FROM THE DATE OF PURCHASE AS DESCRIBED ABOVE.

Some states do not allow limitations on how long an implied warranty last so the above limitation may not apply to you.

BISSELL customer Service

For information about repairs or replacement parts, or questions about your warranty, call:

BISSELL Customer Service

1-855-544-7336

Monday - Friday 8 a.m. — 5 p.m. ET

Or write:

BISSELL Business Ventures, LLC.

PO Box 3606

Grand Rapids MI 49501

ATTN: Customer Service

Or visit the BISSELL website - **www.bissellcommercial.com**

When contacting BISSELL, have model number of cleaner available.

Please record your Model Number: _____

Please record your Purchase Date: _____

NOTE: Please keep your original sales receipt. It provides proof of purchase date in the event of a warranty claim. See Warranty on page 11 for details.

Bissell[®]
BigGreen Commercial[™]

©2011 BISSELL Business Ventures, LLC.
Grand Rapids, Michigan
All rights reserved. Printed in China
Part Number 120-4358
Rev 7/11
Visit our website at:
www.bissellcommercial.com