

GENERAC

Owner's Manual

RS5500 / RS7000E PowerDial™ Series Portable Generators

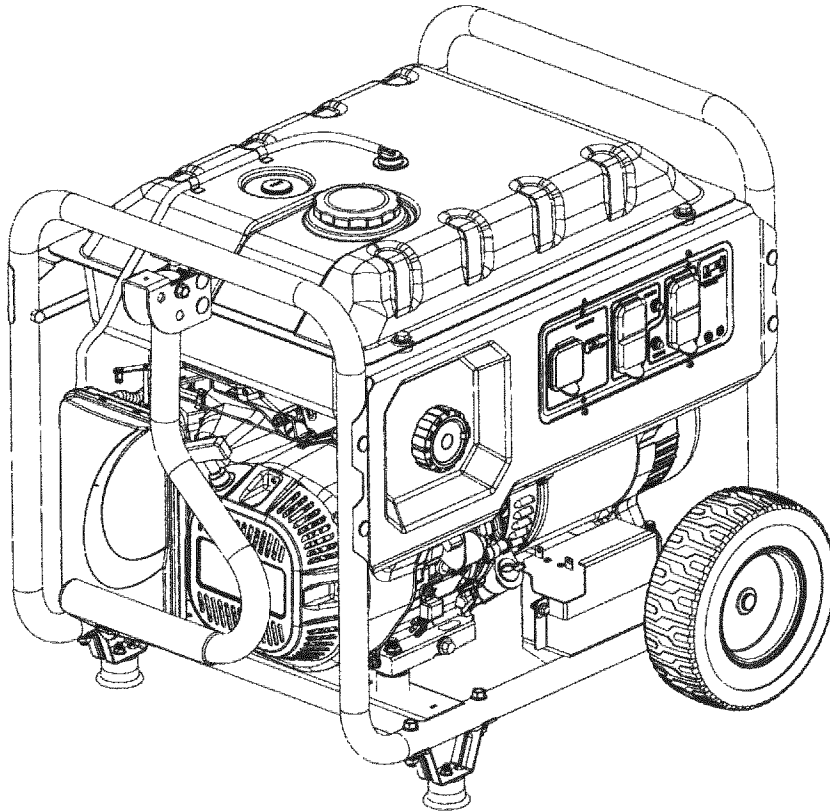

⚠ DANGER!

- ⚠ NOT INTENDED FOR USE IN CRITICAL LIFE SUPPORT APPLICATIONS.**
- ⚠ DEADLY EXHAUST FUMES! USE OUTSIDE, ONLY, FAR AWAY FROM WINDOWS, DOORS AND VENTS!**
- ⚠ SAVE THIS MANUAL. Provide this manual to any operator of the generator.**

Reference all appropriate documentation.
This manual should remain with the unit.

www.generac.com or 1-888-436-3722

WARNING!

California Proposition 65

Engine exhaust and some of its constituents are known to the state of California to cause cancer, birth defects, and other reproductive harm.

WARNING!

California Proposition 65

This product contains or emits chemicals known to the state of California to cause cancer, birth defects, and other reproductive harm.

Table of Contents

Unit Information	i
Frequently Asked Questions	ii
Section 1 - Safety	1
1.1 Read This Manual Thoroughly	1
1.2 Safety Rules	1
Section 2 - General Information	5
2.1 Unpacking	5
2.2 Assembly	5
2.3 Emissions Information	6
2.4 Product Specifications	7
2.5 Know The Generator	7
2.6 Before Starting the Generator	10
Section 3 - Operation	13
3.1 How To Use The Generator	13
3.2 Generator Loads	14
3.3 Wattage Reference Guide	14
3.4 Starting The Generator (Electric Start)	15
3.5 Starting The Generator (Manual/Recoil) Starting	15
3.6 Stopping The Generator	16
3.7 Restarting the Generator	16
3.8 Low Oil Level Shutdown System	16
Section 4 - Maintenance	17
4.1 General Recommendations	17
4.2 Generator Cleaning	17
4.3 Service Intervals	17
4.4 Generator Storage	22
Section 5 - Troubleshooting	23
5.1 Troubleshooting Guide	23
5.2 Replacement Service Parts	24

Unit Information

Use this page to record important information about your generator set.

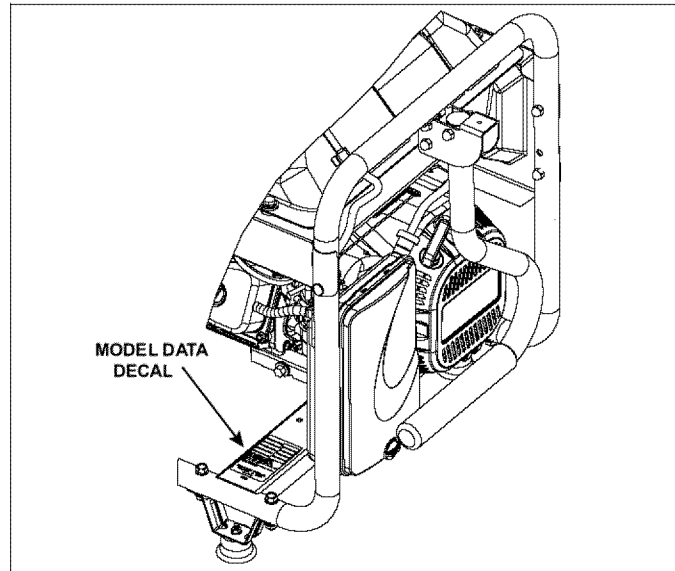

Record the information found on your unit data label on this page. The location of the unit data label is shown here.

When contacting an Authorized Service Dealer about parts and service, always supply the complete model number and serial number of the unit.

MODEL NO:	
SERIAL NO:	

Operation and Maintenance: Proper maintenance and care of the generator ensures a minimum number of problems and keep operating expenses at a minimum. It is the operator's responsibility to perform all safety checks, to make sure that all maintenance for safe operation is performed promptly, and to have the equipment checked periodically by an Authorized Service Dealer. Normal maintenance, service and replacement of parts are the responsibility of the owner/operator and, as such, are not considered defects in materials or workmanship within the terms of the warranty. Individual operating habits and usage may contribute to the need for additional maintenance or service.

When the generator requires servicing or repairs, contact an Authorized Service Dealer for assistance. Authorized service technicians are factory-trained and are capable of handling all service needs.

Frequently Asked Questions

This list of Frequently Asked Questions (FAQs) are the frequently asked questions that pertain to ALL Portable models. Some questions may not be applicable to the model(s) covered in this publication.

Please review the Safety Section of your product's Owners or Installation Manual before operating your portable generator.

FUEL INFORMATION

Q: What needs to be done to the fuel before extended storage?

A: Fuel that is not going to be used, even for short periods of time should be treated with fuel stabilizer to slow the rate of deterioration, gumming or varnish formation. Following the fuel stabilizer manufacturer's recommendations, treat the quantity of fuel remaining in the fuel tank. Open the fuel valve, start and operate the engine for 30 minutes. This circulates treated fuel through lines and carburetor. The fuel can be drained or left in the tank.

Q: Can I convert my portable generator to run on a different fuel besides gasoline?

A: We do not offer any type of fuel conversion kit for our portable generators. Aftermarket conversion kits are available on the Internet. However, if a customer decides to convert the fuel using an aftermarket kit, the warranty is void.

Q: Can I use any type of gasoline?

A: Regular unleaded gasoline, with an octane rating of 87 and no more than 10% ethanol, is preferred. Never use an E85 fuel or a mixture of oil and gasoline designated for two cycle engines. Utilizing a higher grade premium fuel will not yield any increase in power output or improved performance.

Q: The fuel capacity in my owner's manual seems incorrect.

A: The fuel capacity listed is the total interior volume for the fuel tank. Air space is required to allow for expansion of the gasoline during warmer temperatures. So the actual amount of gasoline that will fit in the tank is typically less than the stated fuel tank capacity.

Q: How do I drain the fuel?

A: Actually, treating the fuel for storage is a better option. The treated fuel can then be left in the tank. Fuel can be removed through the fill opening using an automotive style siphon. Exercise all appropriate cautions when handling fuel.

MAINTENANCE & OIL INFORMATION

Q: I am out of the recommended oil, but I need to operate my generator. What are my options?

A: In an emergency, oil with an API rating of SH, SJ, SK, CF-4, ILSAC, GF-1, GF-2 or GF-4 can be used. It can be mineral, semi-synthetic or synthetic. Any of the following viscosities are permissible: SAE 5W-30, 10W-30, 10W-40, 20W-50, 30 or 40 weight. Change the oil as soon as possible using Generac oil, per the owner's manual recommendations.

Q: If no dipstick is included on my model's engine. How do I know when I have put enough oil in my portable generator?

A: The customer should fill the oil to the bottom of the cap's threads on the crankcase. The oil should always be checked and filled when your engine has cooled completely.

Q: Should I screw the oil cap/ dipstick all the way down when checking the oil level?

A: When checking the oil, the oil fill cap/dipstick should be screwed in all the way. The oil level should be checked and filled when the engine has cooled completely.

Q: For example, the manual says the oil capacity is 1.7 quarts. When I add 1.7 quarts, it doesn't reach the threads on the crankcase.

A: Add enough oil to reach the bottom of the threads on the crankcase, even if it is more than the manual recommends.

OPERATION

Q: The hourmeter said it was time to service the air filter. After the service has been performed, does anything need to be done to the hourmeter?

A: The hourmeter will alert the owner continuously for one hour (of run time) before and until one hour after scheduled maintenance has been reached. This includes oil changes (at 100 hours) or air filter service (at 200 hours). As hours of operation continue to accumulate, the hourmeter will automatically reset itself until the next 100 or 200 hour service interval is reached. See the Hourmeter section of your owner's manual for additional information. The hourmeter on some generator models have a reset button that allows the operator to move between maintenance intervals and reset intervals by holding the reset button for nine seconds. NOTE: Not all generator models have the reset button.

Q: How do I adjust the valve clearance?

A: Valve clearance adjustment is critical to proper engine operation and requires special tools and training. Instructions are covered in the Valve Clearance Adjustment section of your owner's manual. However, if you are uncomfortable performing this service procedure, have your dealer maintain the generator's valve clearance at the intervals specified.

Q: What do the Red and Blue colored dots on the extension cord receptacles mean?

A: These indicate the need to balance the loads on the generator when adding electrical devices. For example, if you are adding two electrical devices, plug one into a red outlet and the other into a blue outlet rather than two red or two blue outlets. This will help balance the loads on the generator. NOTE: This only applies to models with extension cords.

Q: Can I operate my generator in the rain?

A: Portable generators should never be operated inside an enclosed space or contrary to any provision or warning contained in your Owner's Manual. However, portable generators are intended to be used during extreme weather and for the sensitive electronics on them, it is best if some sort of open covering can be used to protect it from direct rain or snow. Great options would be a car port or boat canopy with four open sides or a tarp hung from a tree. It is very important to provide adequate ventilation for the generator, so any sort of protection should be at least five feet from any side (including the top of the unit) while in use. Additionally, a portable generator should always be stored inside when not in use to prevent unnecessary wear and tear. BE ADVISED, the generator should NEVER be used in any enclosed space including, without limitation, a shed, home, garage, trailer or vehicle, even if the doors are left open, as this can be a serious fire hazard and carbon monoxide risk.

Q: How long can I operate the generator? Does it need a "break"?

A: Your generator can be operated continually. The highest priority is to maintain a proper oil level. Each time you add fuel, check the oil level as well. Add oil, if necessary, to keep the level at the upper mark on the dipstick. See the Checking Oil Level and Adding Fuel sections of your owner's manual for complete instructions on adding fuel and oil.

Q: Is there anything special I need to do before I turn off my generator? Should I unplug my electrical devices?

A: Yes, remove all loads before turning the generator off. First, turn off all appliances, lights and items being powered by the generator. Then, unplug the items from the generator's receptacles and allow the generator to cool. Once you've done this, it is safe to turn the generator off. NEVER turn the generator off while loads are applied. Refer to the Generator Loads section of your owner's manual for complete instructions on adding and removing electrical devices.

Q: If the generator is being used, how do I connect or disconnect electrical devices?

A: NEVER start or stop the generator's engine with running electrical devices plugged into the generator. When the generator is turned off, you can only connect electrical devices that are turned off. When the generator is turned on, you may connect electrical devices that are turned on or off.

Q: Why do I need to ground my portable generator?

A: Proper grounding of the generator, when used to back-up a building's utility power, will prevent electrical shock in the event of a ground fault condition in the generator or connected electrical devices. Proper grounding also helps dissipate static electricity which often builds up in ungrounded devices. The National Electric Code requires that the frame and externally conductive parts of this generator be properly connected to an approved earth ground. Local electrical codes may also require proper grounding of the unit. For that purpose, connecting a No. 10 AWG (American Wire Gauge) stranded copper wire to the grounding lug and to an earth driven copper or brass grounding rod (electrode) provides adequate protection against electrical shock. However, local codes may vary widely. Consult with a local electrician for grounding requirements in the area.

Q: How often should I start / operate my generator between outages?

A: Generac recommends starting a generator once a month and running the unit for about 30 minutes. Starting the unit monthly will help make sure that the generator is ready to turn on in the event of an outage.

BATTERY INFORMATION

Q: How often do I have to charge the generator's battery?

A: If the starter will not turn the engine over, charge the battery using the charger provided with your generator. The charger should be connected for no longer than 48 hours.

Q: My generator's battery will no longer accept a charge. What is the procedure for replacing a battery?

A: Complete battery replacement procedures can be found in the Battery Replacement section of your owner's manual.

Q: How do I charge my portable generator's battery?

A: Most portable generators do not charge their batteries when running. Two Generac GP models, the 15,000 and 17,500 and all electric start XP models charge their batteries while operating. Generac electric start generators, except those two GP models come with an external charger. The customer should charge the battery at least once a month for 24-48 hours in preparation for usage. If the battery is dead, most of the portables have a recoil backup (pull start). In emergency situations, the customer can charge the battery by plugging the charger cord into the receptacle on the generator while it is running. This is not recommended for typical operation.

GENERAL INFORMATION

Q: What are the decibel levels of portable generators?

A: Since there is not an industry accepted standard specifying how to perform sound level tests of portable generators, Generac does not publish sound test data. Our portable generators feature a low-tone muffler straight from the factory. We do not offer a kit or recommend making any changes to the generator or exhaust system, as that can void the warranty.

Q: Can I add electric start to my pull start generator?

A: Generac does not offer any kits or accessories to add electric start to a pull start generator. Making any changes can void the generator warranty.

Q: Does my warranty cover travel/pickup for my generator?

A: No. The dealer will not come out to the customer or pick up the portable generator from the customer unless the customer has paid them to do so.

Q: What is "idle control" and what does it offer the owner?

A: The idle control feature operates the generator at a lower rpm when little or no load is applied. Idle control then increases the engine speed to supply greater generator output to meet demands when loads are applied. This saves fuel, generator wear and lowers noise levels.

Section 1 Safety

Thank you for purchasing this model by Generac Power Systems, Inc. This model is a compact, high performance, air-cooled, engine driven generator designed to supply electrical power to operate electrical loads where no utility power is available or in place of utility due to a power outage.

1.1 — READ THIS MANUAL THOROUGHLY

If any portion of this manual is not understood, contact the nearest Authorized Dealer for starting, operating and servicing procedures.

The operator is responsible for proper and safe use of the equipment. We strongly recommend that the operator read this manual and thoroughly understand all instructions before using the equipment. We also strongly recommend instructing other users to properly start and operate the unit. This prepares them if they need to operate the equipment in an emergency.

The generator can operate safely, efficiently and reliably only if it is properly located, operated and maintained. Before operating or servicing the generator:

- Become familiar with and strictly adhere to all local, state and national codes and regulations.
- Study all safety warnings in this manual and on the product carefully.

Become familiar with this manual and the unit before use.

The manufacturer cannot anticipate every possible circumstance that might involve a hazard. The warnings in this manual, and on tags and decals affixed to the unit are, therefore, not all inclusive. If using a procedure, work method or operating technique that the manufacturer does not specifically recommend, ensure that it is safe for others. Also make sure the procedure, work method or operating technique utilized does not render the generator unsafe.

THE INFORMATION CONTAINED HEREIN WAS BASED ON MACHINES IN PRODUCTION AT THE TIME OF PUBLICATION. GENERAC RESERVES THE RIGHT TO MODIFY THIS MANUAL AT ANY TIME.

Save these instructions for future reference. If you loan this device to someone, ALWAYS loan these instructions to the individual as well.

1.2 — SAFETY RULES

Throughout this publication, and on tags and decals affixed to the generator, DANGER, WARNING, CAUTION and NOTE blocks are used to alert personnel to special instructions about a particular operation that may be hazardous if performed incorrectly or carelessly. Observe them carefully. Their definitions are as follows:

▲ DANGER!

INDICATES A HAZARDOUS SITUATION OR ACTION WHICH, IF NOT AVOIDED, WILL RESULT IN DEATH OR SERIOUS INJURY.

▲ CAUTION!

Indicates a hazardous situation or action which, if not avoided, could result in death or serious injury.

▲ WARNING!

Indicates a hazardous situation or action which, if not avoided, could result in minor or moderate injury.

NOTE:

Notes contain additional information important to a procedure and will be found within the regular text body of this manual.

These safety warnings cannot eliminate the hazards that they indicate. Common sense and strict compliance with the special instructions while performing the action or service are essential to preventing accidents.

Four commonly used safety symbols accompany the **DANGER**, **WARNING** and **CAUTION** blocks. The type of information each indicates is as follows:



This symbol points out important safety information that, if not followed, could endanger personal safety and/or property of others.



This symbol points out potential explosion hazard.



This symbol points out potential fire hazard.



This symbol points out potential electrical shock hazard.



WARNING: Hearing protection recommended.



1.2.1 — General Hazards

- NEVER operate in an enclosed area, in a vehicle, or indoors EVEN IF doors and windows are open.
- For safety reasons, the manufacturer recommends that the maintenance of this equipment is carried out by an Authorized Dealer. Inspect the generator regularly, and contact the nearest Authorized Dealer for parts needing repair or replacement.
- Operate generator only on level surfaces and where it will not be exposed to excessive moisture, dirt, dust or corrosive vapors.
- Keep hands, feet, clothing, etc., away from drive belts, fans, and other moving parts. Never remove any fan guard or shield while the unit is operating.
- Certain parts of the generator get extremely hot during operation. Keep clear of the generator until it has cooled to avoid severe burns.
- Do NOT operate generator in the rain.
- Do not alter the construction of the generator or change controls which might create an unsafe operating condition.
- Never start or stop the unit with electrical loads connected to receptacles AND with connected devices turned ON. Start the engine and let it stabilize before connecting electrical loads. Disconnect all electrical loads before shutting down the generator.
- Do not insert objects through unit's cooling slots.
- When working on this equipment, remain alert at all times. Never work on the equipment when physically or mentally fatigued.
- Never use the generator or any of its parts as a step. Stepping on the unit can stress and break parts, and may result in dangerous operating conditions from leaking exhaust gases, fuel leakage, oil leakage, etc.

1.2.2 — Exhaust & Location Hazards

Never operate in an enclosed area or indoors! NEVER use in the home, in a vehicle, or in partly enclosed areas such as garages, EVEN IF doors and windows are open! ONLY use outdoors and far from open windows, doors, vents, and in an area that will not accumulate deadly exhaust.

⚠ DANGER

Using a generator indoors CAN KILL YOU IN MINUTES.

Generator exhaust contains carbon monoxide. This is a poison you cannot see or smell.



NEVER use inside a home or garage, EVEN IF doors and windows are open.

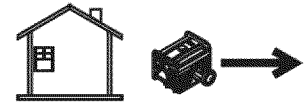

Only use OUTSIDE and far away from windows, doors, and vents.

- The engine exhaust fumes contain carbon monoxide, which you cannot see or smell. This poisonous gas, if breathed in sufficient concentrations, can cause unconsciousness or even death.
- Adequate, unobstructed flow of cooling and ventilating air is critical to correct generator operation. Do not alter the installation or permit even partial blockage of ventilation provisions, as this can seriously affect safe operation of the generator. The generator MUST be operated outdoors.
- This exhaust system must be properly maintained. Do nothing that might render the exhaust system unsafe or in noncompliance with any local codes and/or standards.
- Always use a battery operated carbon monoxide alarm indoors, installed according to the manufacturer's instructions.
- If you start to feel sick, dizzy, or weak after the generator has been running, move to fresh air IMMEDIATELY. See a doctor, as you could have carbon monoxide poisoning.

1.2.3 — Electrical Hazards

- The generator produces dangerously high voltage when in operation. Avoid contact with bare wires, terminals, connections, etc., while the unit is running, even on equipment connected to the generator. Ensure all appropriate covers, guards and barriers are in place before operating the generator.
- Never handle any kind of electrical cord or device while standing in water, while barefoot or while hands or feet are wet. **DANGEROUS ELECTRICAL SHOCK MAY RESULT.**
- The National Electric Code (NEC) requires the frame and external electrically conductive parts of the generator be properly connected to an approved earth ground. Local electrical codes may also require proper grounding of the generator. Consult with a local electrician for grounding requirements in the area.

- Use a ground fault circuit interrupter in any damp or highly conductive area (such as metal decking or steel work).
- Do not use worn, bare, frayed or otherwise damaged electrical cord sets with the generator.
- Before performing any maintenance on the generator, disconnect the engine starting battery (if equipped) to prevent accidental start up. Disconnect the cable from the battery post indicated by a NEGATIVE, NEG or (-) first. Reconnect that cable last.
- In case of accident caused by electric shock, immediately shut down the source of electrical power. If this is not possible, attempt to free the victim from the live conductor. **AVOID DIRECT CONTACT WITH THE VICTIM.** Use a non-conducting implement, such as a rope or board, to free the victim from the live conductor. If the victim is unconscious, apply first aid and get immediate medical help.

1.2.4 — Fire Hazards

- Gasoline is highly FLAMMABLE and its vapors are EXPLOSIVE. Never permit smoking, open flames, sparks or heat in the vicinity while handling gasoline.
- Never add fuel while unit is running or hot. Allow engine to cool completely before adding fuel.
- **Never fill fuel tank indoors.** Comply with all laws regulating storage and handling of gasoline.
- **Do not overfill the fuel tank. Always allow room for fuel expansion.** If tank is over-filled, fuel can overflow onto a hot engine and cause FIRE or an EXPLOSION. Never store generator with fuel in tank where gasoline vapors might reach an open flame, spark or pilot light (as on a furnace, water heater or clothes dryer). FIRE or EXPLOSION may result. Allow unit to cool entirely before storage.
- Wipe up any fuel or oil spills immediately. Ensure that no combustible materials are left on or near the generator. Keep the area surrounding the generator clean and free from debris and maintain a clearance of five (5) feet on all side to allow for proper ventilation of the generator.
- Do not insert objects through unit's cooling slots.
- **Never** operate the generator if connected electrical devices overheat, if electrical output is lost, if engine or generator sparks or if flames or smoke are observed while unit is running.
- Keep a fire extinguisher near the generator at all times.

1.2.5 — Standards Index

1. National Fire Protection Association (NFPA) 70: The NATIONAL ELECTRIC CODE (NEC) available from www.nfpa.org
2. National Fire Protection Association (NFPA) 5000: BUILDING CONSTRUCTION AND SAFETY CODE available from www.nfpa.org
3. International Building Code available from www.iccsafe.org
4. Agricultural Wiring Handbook available from www.nerc.org , Rural Electricity Resource Council P.O. Box 309 Wilmington, OH 45177-0309
5. ASAE EP-364.2 Installation and Maintenance of Farm Standby Electric Power available from www.asabe.org, American Society of Agricultural & Biological Engineers 2950 Niles Road, St. Joseph, MI 49085

This list is not all inclusive. Check with the Authority Having Local Jurisdiction (AHJ) for any local codes or standards which may be applicable to your jurisdiction.

This page intentionally left blank.

Section 2 **General Information**

2.1 — UNPACKING

- Remove all packaging material.
- Remove separate items.
- Remove the generator from carton.

2.1.1 — Documents and Accessories (not shown)

Check all contents. If any parts are missing or damaged, call 1-888-436-3722.

- Product Registration Cards
- Warranty and Emission Sheets
- 1 - Owner's Manual
- 1 - Quart Oil - SAE 30
- 1 - 20 ft. Extension Cord
- 1 - Battery Charger (7.0 kW only)

2.1.2 — Loose Components

- 1 - Handle Assembly (not in hardware bag)
- 2 - Rubber Feet (not in hardware bag) (M)
- 2 - Frame Foot (not in hardware bag) (L)
 - 1 - Hardware Bag (containing the following):
 - 2 - Cotter Pins (A)
 - 2 - Washers (1/2 in) (B)
 - 2 - Never-Flat Wheels (C)
 - 2 - Axle Pins (D)
 - 2 - Hex Flanged Nuts (M6) (E)
 - 4 - Hex Bolt (M8) (F)
 - 2 - Hex Bolt (M6) (G)
 - 4 - Nut, Hex Flange (M8) (H)
 - 2 - Nut, Acorn (M8) (J)
 - 2 - Carriage Bolt (M8) (K)

2.2 — ASSEMBLY

The generator requires some assembly prior to usage. If problems arise when assembling the generator, call 1-888-436-3722.

2.2.1 — Required Tools

- 3/8 drive Ratchet
- Sockets: 13, 12, 8 mm (1 ea)
- Wrenches: 13, 10 mm (1 ea), 8 mm (2)
- Needle nosed pliers

2.2.2 — Installing Wheels

NOTE:

The wheels are not intended for over-the-road use.

1. Install the Wheels as follows (Figure 2-1):
 - Slide the Axle Pin (D) through the Wheel (C), Wheel Bracket on the frame and a 5/8" Flat Washer (B).
 - Insert the Cotter Pin (A) through the Axle Pin. Use the needle nosed pliers to bend open to lock in place.

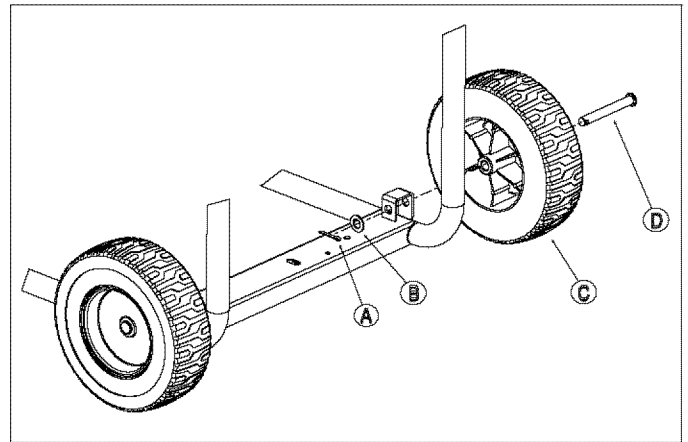

Figure 2-1. Wheel Assembly

2.2.3 — Installing Frame Feet

1. Install the Frame Foot Assemblies as shown (Figure 2-2).
 - Slide the M8 Hex Bolts (F) through the holes in the Frame Rail.
 - Slide the Frame Foot (L) onto the Hex Head Bolts. Then install the Locking Flange Nuts (H). Tighten securely using a ratchet, 12 mm socket and 13 mm wrench.
 - Slide the M6 Hex Bolt (G) through the Rubber Foot (M) and Frame Foot (L). Then install M6 Hex Flange Nut (E). Tighten securely using 10 mm wrench and 8 mm socket.
2. Repeat the Step 1 to install the other Frame Foot Assembly.

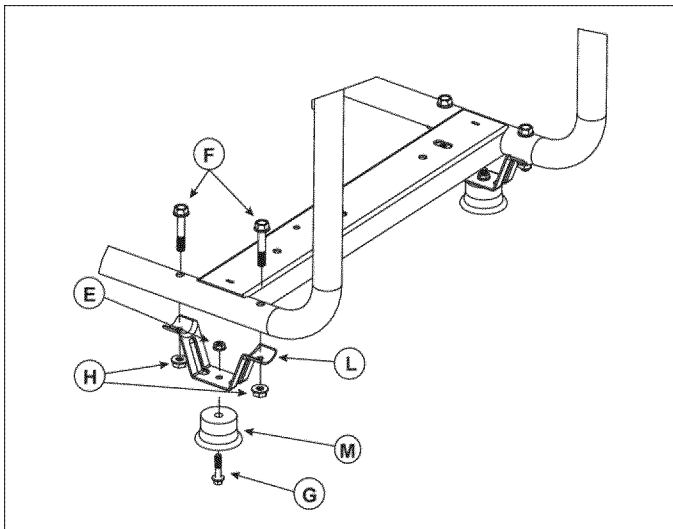

Figure 2-2. Frame Foot Assemblies

2.2.4 — Installing Handle

1. Place the handle over the frame tabs as shown. (Figure 2-3).
2. Slide Carriage Bolts M8 (K) through the handle brackets and tabs.
3. Place a nut (J) on each Carriage Bolt (K) and tighten securely using a ratchet and a 13 mm socket.

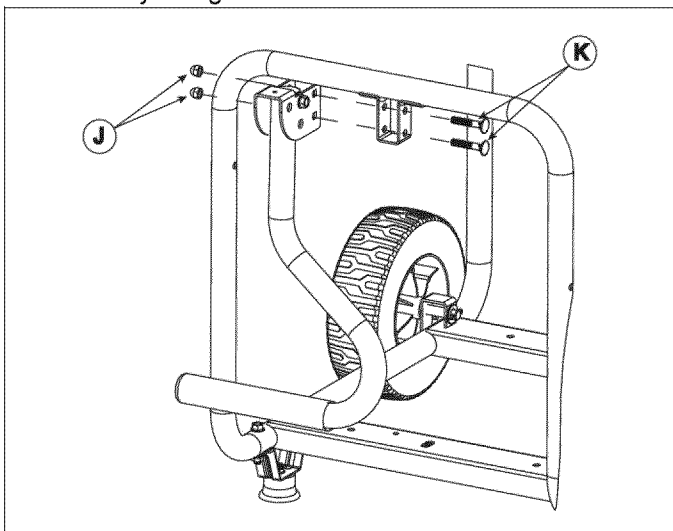

Figure 2-3. Handle

2.2.5 — Battery Cables (7.0kW only)

NOTE:

The battery shipped with the generator has been fully charged. The positive and negative cables are NOT connected and must be attached prior to operation.

The **NEGATIVE (black) (-)** battery cable should:

1. Always be **DISCONNECTED FIRST**.
2. Always be **CONNECTED LAST**.

Use two 8 mm wrenches to tighten battery hardware.

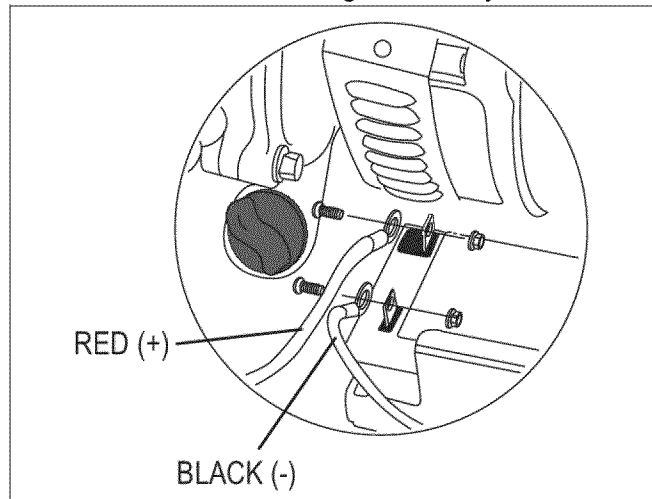

Figure 2-4. Battery Connections (7.0 kW only)

NOTE:

A battery may lose some of its charge when not in use for prolonged periods of time. If the battery is unable to crank the engine, plug in the 12V charger included in the accessory box (see the Charging a Battery - Section 4: Maintenance). **RUNNING THE GENERATOR DOES NOT CHARGE THE BATTERY.**

2.3 — EMISSIONS INFORMATION

Locate the emissions compliance decal on the engine to determine what standards the generator meets, and to determine which warranty applies. This generator is certified to operate on gasoline. The emission control system includes the following components (if equipped):

- Air Induction System
 - Intake Pipe / Manifold
 - Air Cleaner
- Fuel System
 - Carburetor/Mixer Assembly
 - Fuel Regulator
- Ignition System
 - Spark Plug
 - Ignition Module
- Exhaust System
 - Exhaust Manifold
 - Muffler
 - Pulsed Air Valve
 - Catalyst

2.4 — PRODUCT SPECIFICATIONS - 5.5 / 7.0 kW

2.4.1 — Generator Specifications

Rated Power	5.5 / 7.0 kW
Surge Power	6.87 / 8.75 kW
Rated AC Voltage.....	120/240
Rated AC Load	
Current @ 240V	22.9 / 29.2 Amps**
Current @ 120V	45.8 / 58.4 Amps**
Rated Frequency	60 Hz @3600 RPM
Phase	Single Phase
Operating Temperature Range	0 °F (-8 °C) to 104 °F (40 °C)*

* When operated above 77 °F (25 °C) there may be a decrease in power.

** Maximum wattage and current are subject to, and limited by, such factors as fuel Btu content, ambient temperature, altitude, engine condition, etc. Maximum power decreases about 3.5% for each 1,000 feet above sea level; and will also decrease about 1% for each 10 °F (-12.2 °C) above 60 °F (16 °C) ambient temperature.

2.4.2 — Engine Specifications - 5.5 / 7.0 kW

Displacement	389 cc/420 cc - 5.5 kW / 7 kW
Spark Plug Type	Champion N9YC
Spark Plug Gap	0.028-0.031 inch (0.70-0.80 mm)
Fuel Capacity	6.7 gallons (25.4 liters) - 5.5 kW
.....	7.5 gallons (28.4 liters) - 7.0 kW
Oil Type	see Section 2.6.1
Oil Capacity	1.06 Quarts (1.0 liters)
Run Time at 50% Load ...	11 Hour /12 hours - 5.5/7.0 kW

2.5 — KNOW THE GENERATOR

Compare the generator to Figures 2-5 through 2-7 to become familiarized with the locations of various controls and adjustments.

Read the Owner's Manual and Safety Rules before operating this generator.

- 120/240 Volt AC, 30 Amp, Locking Receptacle** – Supplies electrical power for the operation of 120 and/or 240 Volt AC, 30 Amp, single-phase, 60 Hz electrical lighting, appliance, tool and motor loads.
- Circuit Breakers (AC)** – A 2-pole circuit breaker protects the rated output of the 30 Amp Twistlock outlet (CSA only). Each duplex receptacle and the 30 Amp Twistlock are provided with a push-to-reset circuit breakers to protect against electrical overload (49 State).
- Hourmeter** - Tracks hours of operation to perform required maintenance.
- Battery Charger Input (7.0 kW only)** – Permits recharging of the battery. A 12 volt charger is included. A 1.50 Amp in-line fuse is located behind the control panel to protect the battery when charging.
- 120 Volt AC, 20 Amp Duplex Outlets** – Supplies electrical power for the operation of 120 Volt AC, 20 Amp, single-phase, 60 Hz, electrical lighting, appliance, tool and motor loads.

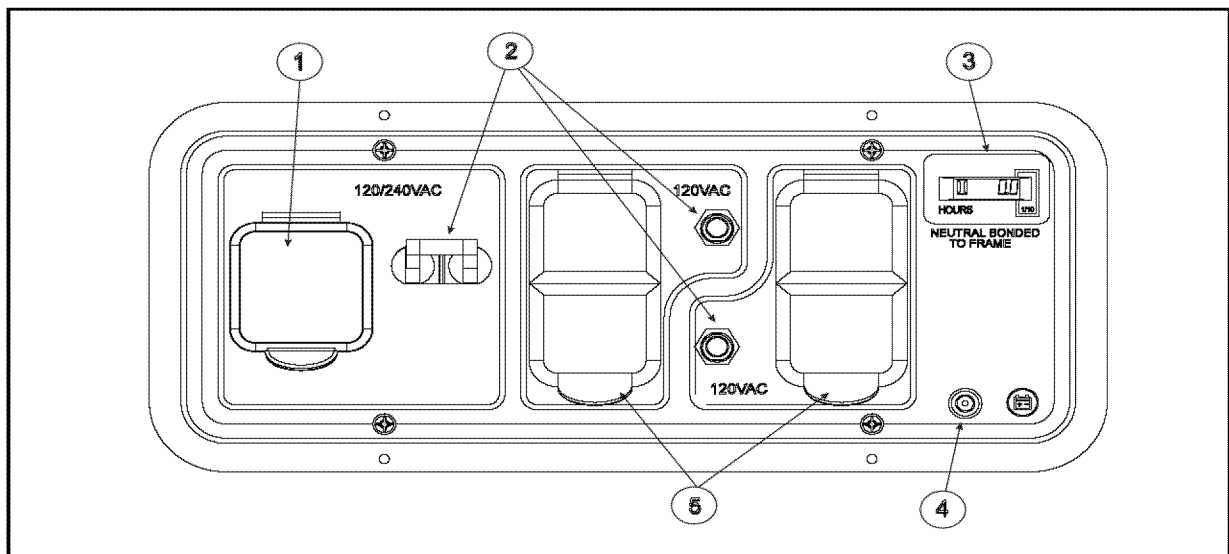

Figure 2-5. Control Panel - CSA

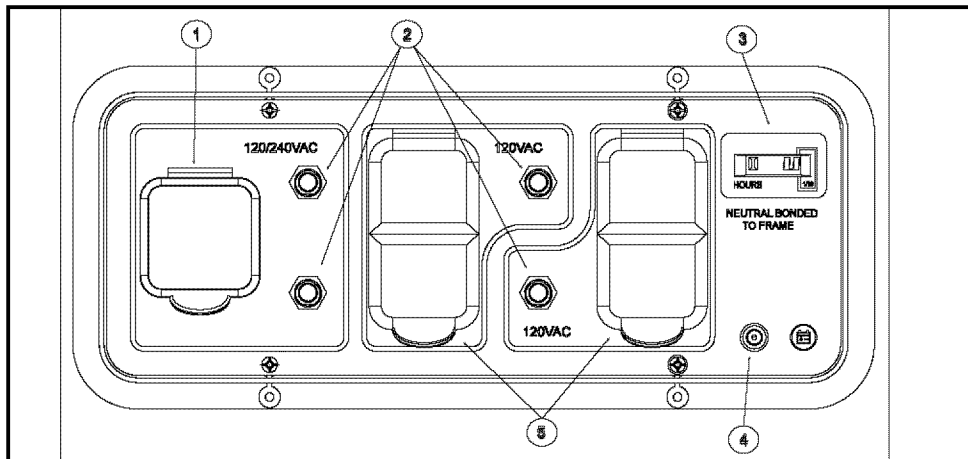

Figure 2-6. Control Panel - 49 State

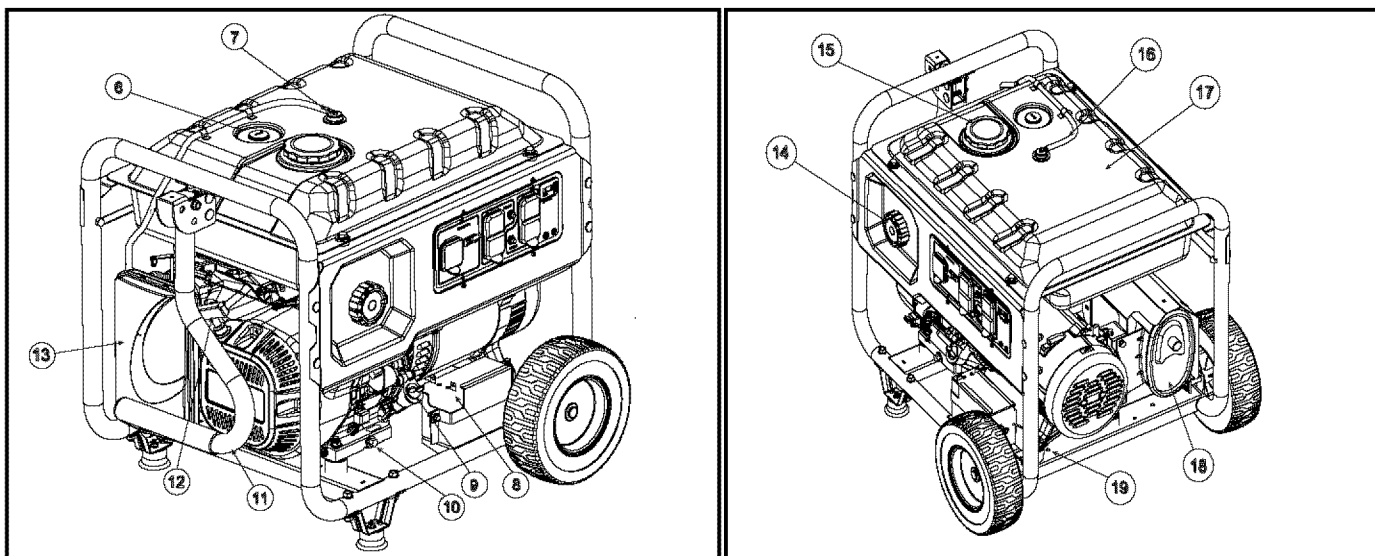

Figure 2-7. Generator Controls

- | | |
|--|---|
| <ul style="list-style-type: none"> 6. Fuel Gauge - shows fuel level in tank. 7. Roll Over Valve - passes fuel vapors to the engine. 8. Battery - provides power for electric starter. (7.0 kW only) 9. Oil Fill/Dipstick - check oil level and add oil here. 10. Oil Drain - drain plug for removing used oil from the crankcase. 11. Handle – used to transport generator. 12. Recoil Starter - used to start engine manually. 13. Air Filter - filters air as it is drawn into the engine. 14. PowerDial – controls the operation of the ON/RUN/STOP functions, choke and fuel valve. 15. Fuel Cap - remove to fill fuel tank. | <ul style="list-style-type: none"> 16. Recovery Hose - vapor tube between roll over valve and the engine. 17. Fuel Tank - holds fuel supply. 18. Muffler – quiets the engine. 19. Grounding Location - grounds the generator to an approved earth ground here. See “Grounding the Generator” for details. |
|--|---|

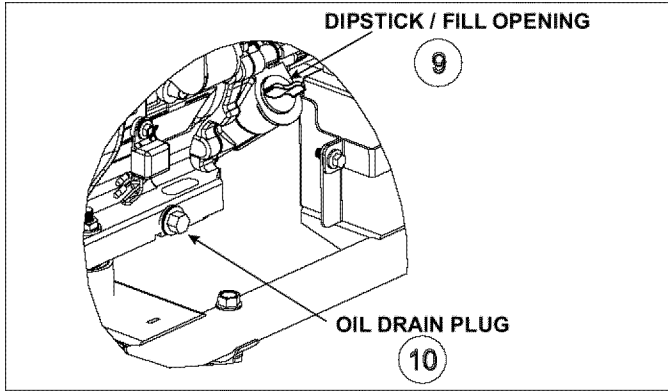

Figure 2-8. Oil Drain/Fill

2.5.1 — Connection Plugs

2.5.1.1 — 120 VAC, 20 Amp, Duplex Receptacle

This is a 120 Volt outlet protected against overload by a 20 Amp push-to-reset circuit breaker (Figure 2-9). Use each socket to power a NEMA 5-15P or 5-20P, 120 Volt AC, single phase, 60 Hz electrical loads requiring up to a combined 2400 watts (2.4 kW) or 20 Amps of current. Use only high quality, well-insulated, 3-wire grounded cord sets rated for 125 Volts at 20 Amps (or greater).

Keep extension cords as short as possible, preferably less than 15 feet long, to prevent voltage drop and possible overheating of wires.

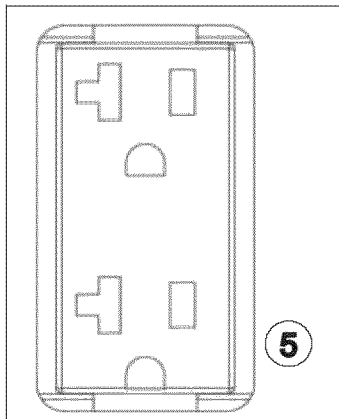

Figure 2-9. 120 Volt AC, 20 Amp, Duplex Receptacle

2.5.1.2 — 120/240 VAC, 30 Amp Locking Receptacle

Use a NEMA L14-30 Plug with this receptacle (rotate to lock/unlock). Connect the supplied 4-wire grounded cord set to the plug and to the desired load. The cord set should be rated for 250 Volts AC at 30 Amps (or greater).

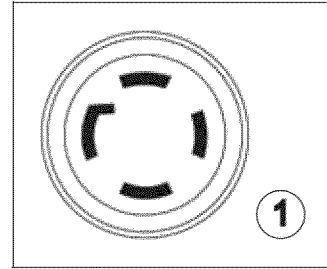

Figure 2-10. 120/240 VAC, 30 Amp Receptacle

Use this receptacle to operate 120 Volt AC, 60 Hz, single phase loads requiring up to 3600 watts (3.6 kW) of power at 30 Amps or 240 Volt AC, 60 Hz, single phase loads requiring up to 7,200 watts of power. The outlet is protected by two 25 Amp (5.5 kW) or two 30 Amp (7.0 kW) push to reset or one 25 Amp or one 30 Amp 2 pole toggle switch to reset (7.0 kW) circuit breaker.

2.5.2 — Extension Cord

Your generator comes with a 20 foot extension cord for connecting appliances and other electrical devices to the generator.

NOTE:

Never start or stop the engine with electrical devices plugged into generator and devices turned on.

The colored dots on the extension cord are indicators for evenly applying the loads to the generator. For example, if two electrical devices are plugged in, place one into a red labeled outlet and the other into a blue labeled outlet, rather than two red or two blue outlets (Figure 2-11).

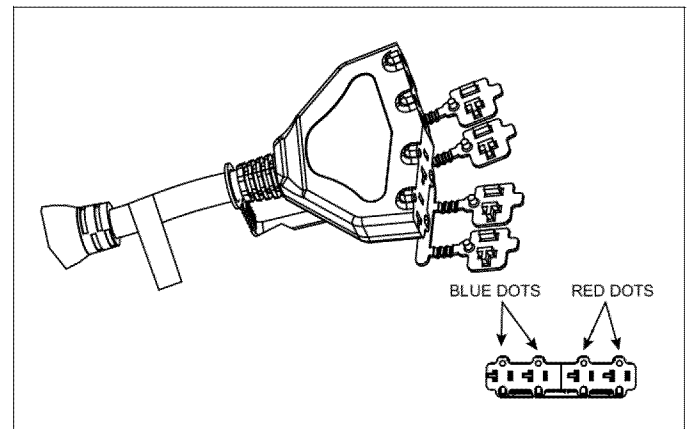

Figure 2-11. Extension cord

2.5.3 — Hourmeter

The Hourmeter tracks hours of operation for scheduled maintenance (Figure 2-12).

There will be a "CHG OIL" message every 100 hours. The message will flash one hour (of run time) before and one hour after each 100 hour interval, providing a two hour window to perform service.

This message will actually begin flashing at 99 hours and disable itself at 101 hours again, providing a two hour window to perform the service.

Every 200 hours the "SVC" icon on the lower left hand corner of the display will flash. The message will flash one hour before and one hour after each 200 hour interval providing a two hour window to perform service.

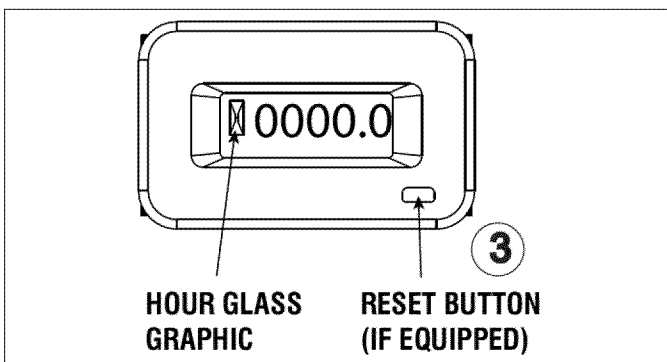

Figure 2-12. Hourmeter

When the hour meter is in the Flash Alert mode, the maintenance message will always alternate with elapsed time in hours and tenths. The hours will flash four times, then alternate with the maintenance message four times until the meter resets itself.

- 100 hours - CHG OIL — Oil Change Interval (Every 100 hrs)
- 200 hours - SVC — Service Air Filter (Every 200 hrs)

NOTE:

The hour glass graphic will flash on and off when the engine is running. This signifies that the meter is tracking hours of operation.

2.5.4 — PowerDial

The PowerDial controls the ON/OFF functions, choke and fuel valve operation. (Figure 2-13)

- The Number 1 position is used when initially starting the engine. In this position, the fuel is on and the choke is fully on (closed). Both the electric start or pull (recoil) start can be used.
- The PowerDial is rotated to position Number 2 during normal operation and to gradually reduce the use of the choke.

- Rotating the PowerDial to the STOP position will stop the engine and shut off the fuel valve flow.

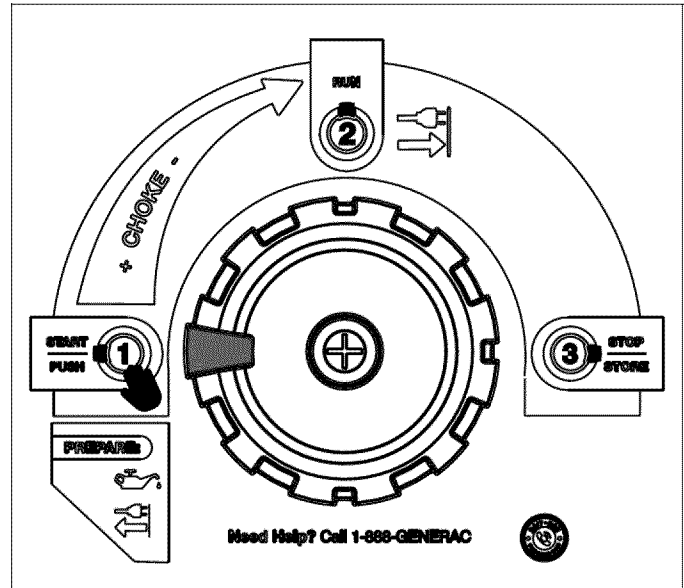

Figure 2-13. PowerDial (RS7000E example shown)

2.6 — BEFORE STARTING THE GENERATOR

Prior to operating the generator:

- Engine oil will need to be added.
- Fill the fuel tank with unleaded fuel.
- Battery cables will need to be connected. (7.0 kW only)

2.6.1 — Adding Engine Oil

The generator has been shipped **WITHOUT** oil. All oil should meet minimum American Petroleum Institute (API) Service Class SJ, SL or better. Use no special additives. Select the oil's viscosity grade according to the expected operating temperature (also see chart).

- Above 40 °F (4.4 °C), use SAE 30
- Below 40 °F (4.4 °C) and down to 10 °F (-12.2 °C), use SAE 10W-30
- All temperatures, use synthetic SAE 5W-30

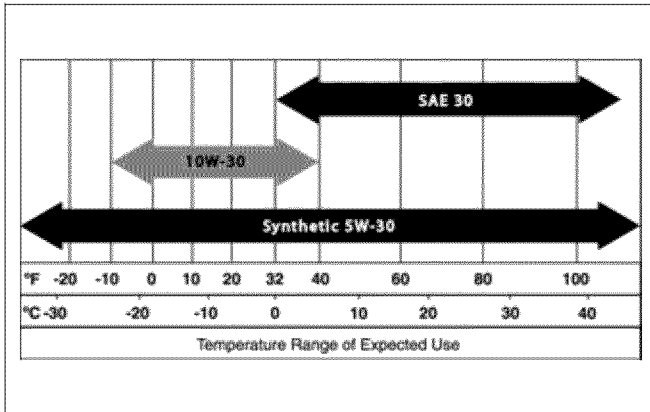

⚠ CAUTION!

Any attempt to start the engine before it has been properly serviced with the recommended oil may result in an engine failure.

1. Place generator on a level surface (not to exceed 15° in any direction).
2. Clean area around oil fill and remove oil fill cap/dipstick.
3. Wipe dipstick clean (Figure 2-14).
4. Slowly fill engine with oil through the oil fill opening. Stop filling occasionally to check oil level. Fill until the level is at the upper mark on the dipstick. **Be careful not to over fill.**

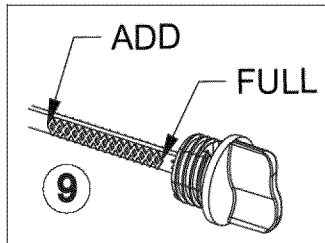

Figure 2-14. Oil Fill/Dipstick

5. Install oil fill cap and finger tighten securely.
6. Check engine oil level before starting each time thereafter.

2.6.2 — Adding Fuel

⚠ DANGER!



Never fill fuel tank indoors. Never fill fuel tank when engine is running or hot. Avoid spilling gasoline on a hot engine. Allow engine to cool entirely before filling fuel tank.



DO NOT light a cigarette or smoke when filling the fuel tank.



Do not overfill the fuel tank. Always leave room for fuel expansion. If the fuel tank is overfilled, fuel can overflow onto a hot engine and cause FIRE or EXPLOSION. Wipe up any spilled fuel immediately.

Use the following instructions for adding gasoline:

Use regular UNLEADED gasoline with the generator engine. Do not mix oil with gasoline.

Do not use gasoline with more than 10% alcohol such as E85 or ethanol.

Clean area around fuel fill cap, remove cap.

Slowly add unleaded gasoline to fuel tank. **Be careful not to overfill** (Figure 2-15).

Install fuel cap and wipe up any spilled gasoline.

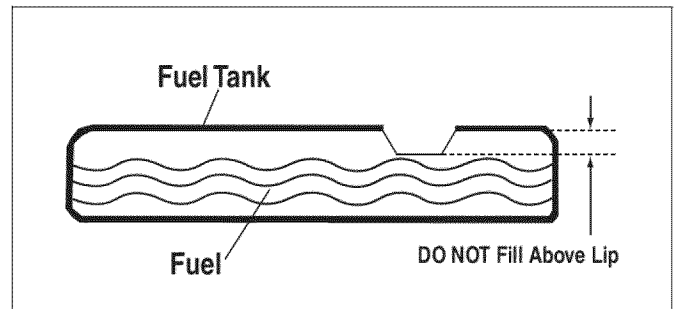

Figure 2-15. Fuel Fill Level

IMPORTANT: It is important to prevent gum deposits from forming in fuel system parts such as the carburetor, fuel hose or tank during storage. Alcohol-blended fuels (called gasohol, ethanol or methanol) can attract moisture, which leads to separation and formation of acids during storage. Acidic gas can damage the fuel system of an engine while in storage. To avoid engine problems, the fuel system should be emptied or treated with a commercially available fuel stabilizer before storage of 30 days or longer. See the "Storage" section. Never use engine or carburetor cleaner products in the fuel tank as permanent damage may occur.

This page intentionally left blank.

Section 3 Operation

3.1 — HOW TO USE THE GENERATOR

See the "To Start the Engine" section for how to safely start and stop the generator and how to connect and disconnect loads. If there are any problems operating the generator, please call 1-888-436-3722.

⚠ DANGER!

- ⚠ Never operate in an enclosed area or indoors! NEVER use in the home, in a vehicle, or in partly enclosed areas such as garages, EVEN IF doors and windows are open! ONLY use outdoors and far from open windows, doors, vents, and in an area that will not accumulate deadly exhaust.**
- ⚠ The engine exhaust fumes contain carbon monoxide, which you cannot see or smell. This poisonous gas, if breathed in sufficient concentrations, can cause unconsciousness or even death.**
- ⚠ Adequate, unobstructed flow of cooling and ventilating air is critical to correct generator operation. Do not alter the installation or permit even partial blockage of ventilation provisions, as this can seriously affect safe operation of the generator. The generator MUST be operated outdoors.**
- ⚠ This exhaust system must be properly maintained. Do nothing that might render the exhaust system unsafe or in noncompliance with any local codes and/or standards.**
- ⚠ Always use a battery operated carbon monoxide alarm indoors, installed according to the manufacturer's instructions.**

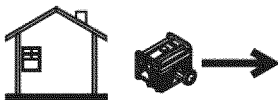
⚠ DANGER	
Using a generator indoors CAN KILL YOU IN MINUTES.	
Generator exhaust contains carbon monoxide. This is a poison you cannot see or smell.	
	
NEVER use inside a home or garage, EVEN IF doors and windows are open.	Only use OUTSIDE and far away from windows, doors, and vents.

3.1.1 — Grounding The Generator When Used As A Portable

This generator has an equipment ground that connects the generator frame components to the ground terminals on the AC output receptacles (see NEC 250.34 (A) for explanation). This allows the generator to be used as a portable without grounding the frame of the generator as specified in NEC 250.34.

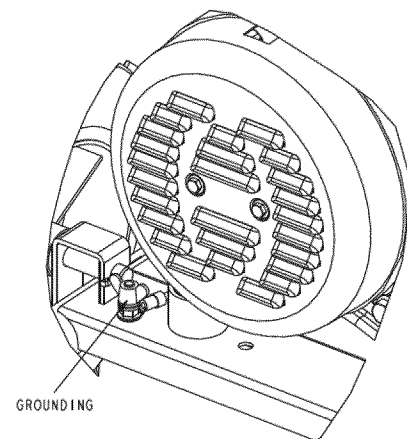

Figure 3-1. Grounding the Generator

3.1.1.1 — Special Requirements

There may be Federal or State Occupational Safety and Health Administration (OSHA) regulations, local codes, or ordinances that apply to the intended use of the generator.

Please consult a qualified electrician, electrical inspector, or the local agency having jurisdiction:

- In some areas, generators are required to be registered with local utility companies.
- If the generator is used at a construction site, there may be additional regulations which must be observed.

3.1.2 — Connecting The Generator To A Building's Electrical System

When connecting directly to a building's electrical system, it is recommended that a manual transfer switch is used. Connections for a portable generator to a building's electrical system must be made by a qualified electrician and in strict compliance with all national and local electrical codes and laws.

3.2 — GENERATOR LOADS

Overloading a generator in excess of its rated wattage capacity can result in damage to the generator and to connected electrical devices. Observe the following to prevent overloading the unit:

- Add up the total wattage of all electrical devices to be connected at one time. This total should **NOT** be greater than the generator's wattage capacity.
 - The rated wattage of lights can be taken from light bulbs. The rated wattage of tools, appliances and motors can usually be found on a data label or decal affixed to the device.
 - If the appliance, tool or motor does not give wattage, multiply volts times ampere rating to determine watts (volts x amps = watts).
 - Some electric motors, such as induction types, require about three times more watts of power for starting than for running. This surge of power lasts only a few seconds when starting such motors. Make sure to allow for high starting wattage when selecting electrical devices to connect to the generator:
1. Figure the watts needed to start the largest motor.
 2. Add to that figure the running watts of all other connected loads.

The Wattage Reference Guide is provided to assist in determining how many items the generator can operate at one time.

NOTE:

All figures are approximate. See data label on appliance for wattage requirements.

3.3 — WATTAGE REFERENCE GUIDE

Device	Running Watts
*Air Conditioner (12,000 Btu)	1700
*Air Conditioner (24,000 Btu)	3800
*Air Conditioner (40,000 Btu)	6000
Battery Charger (20 Amp)	500
Belt Sander (3")	1000
Chain Saw	1200
Circular Saw (6-1/2")	800 to 1000
*Clothes Dryer (Electric)	5750
*Clothes Dryer (Gas)	700
*Clothes Washer	1150
Coffee Maker	1750
*Compressor (1 HP)	2000
*Compressor (3/4 HP)	1800
*Compressor (1/2 HP)	1400
Curling Iron	700
*Dehumidifier	650
Disc Sander (9")	1200
Edge Trimmer	500
Electric Blanket	400
Electric Nail Gun	1200
Electric Range (per element)	1500
Electric Skillet	1250
*Freezer	700
*Furnace Fan (3/5 HP)	875
*Garage Door Opener	500 to 750
Hair Dryer	1200
Hand Drill	250 to 1100
Hedge Trimmer	450
Impact Wrench	500
Iron	1200
*Jet Pump	800
Lawn Mower	1200
Light Bulb	100
Microwave Oven	700 to 1000
*Milk Cooler	1100
Oil Burner on Furnace	300
Oil Fired Space Heater (140,000 Btu)	400
Oil Fired Space Heater (85,000 Btu)	225
Oil Fired Space Heater (30,000 Btu)	150
*Paint Sprayer, Airless (1/3 HP)	600
Paint Sprayer, Airless (hand-held)	150
Radio	50 to 200
*Refrigerator	700
Slow Cooker	200
*Submersible Pump (1-1/2 HP)	2800
*Submersible Pump (1 HP)	2000
*Submersible Pump (1/2 HP)	1500
*Sump Pump	800 to 1050
*Table Saw (10")	1750 to 2000
Television	200 to 500
Toaster	1000 to 1650
Weed Trimmer	500

* Allow 3 times the listed watts for starting these devices.

3.4 — STARTING THE GENERATOR (ELECTRIC START) - 7.0 kW ONLY

⚠ WARNING!

⚠ Never start or stop engine with electrical devices plugged into the receptacles AND devices turned on.

1. To start the engine, turn the PowerDial to the START position (Figure 3-2). This opens the fuel valve and activates (closes) the choke.
2. Press and momentarily hold the PowerDial in the START position. The engine will crank and attempt to start. When the engine starts, release the switch.
3. See Figure 3-3. When the engine starts, rotate the PowerDial gradually clockwise, until the engine runs smoothly, and then fully to the RUN position. Choke operation is reduced as the Power Dial is rotated towards the RUN position. If engine falters, rotate the PowerDial counterclockwise to the START position, to increase the choke, until the engine runs smoothly and then rotate it to the RUN position.

NOTE

In the RUN position, the choke is completely turned OFF and fuel flow is ON.

4. Both generators are also equipped with a manual recoil starter which may be used if the battery is discharged.

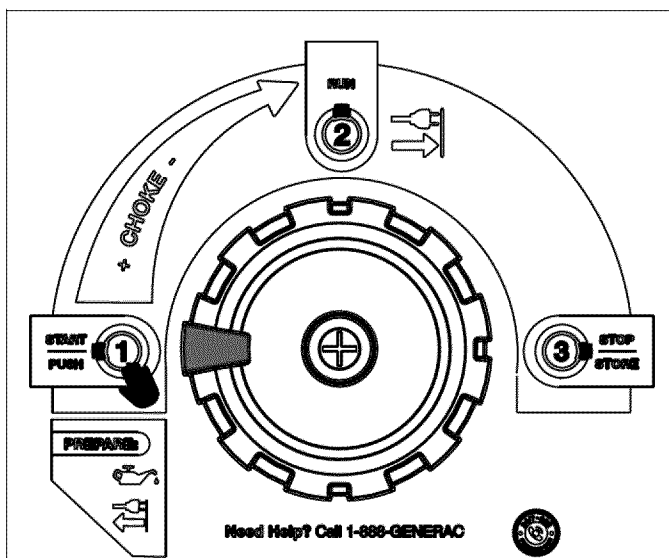

Figure 3-2. PowerDial START Position

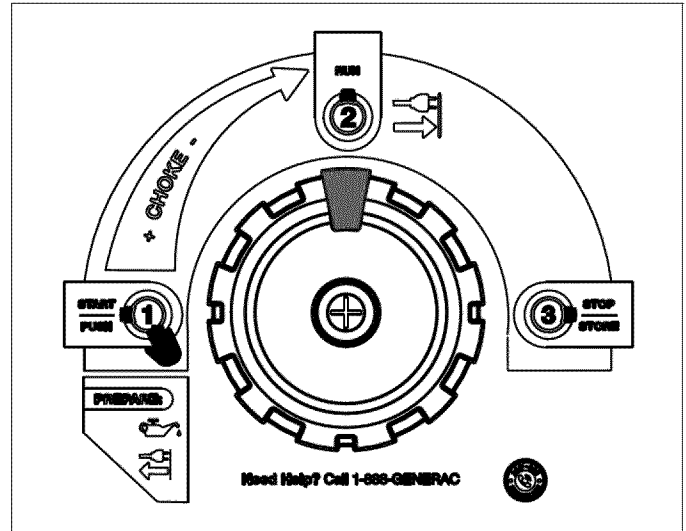

Figure 3-3. PowerDial RUN Position

3.5 — STARTING THE GENERATOR (MANUAL/RECOIL) STARTING

⚠ WARNING!

⚠ Never start or stop engine with electrical devices plugged into the receptacles AND devices turned on.

1. See Figure 3-2. To start the generator, rotate the PowerDial to the START position.
2. Firmly grasp the recoil handle and pull slowly until increased resistance is felt. Pull rapidly up and away to start engine.
3. See Figure 3-3. When the engine starts, rotate the PowerDial gradually clockwise, until the engine runs smoothly, and then fully to the RUN position. Choke operation is reduced as the PowerDial is rotated towards the RUN position. If engine falters, rotate the PowerDial counterclockwise to the START position, to increase the choke, until the engine runs smoothly and then rotate it to the RUN position.

NOTE

If engine fires, but does not continue to run, rotate the PowerDial to “START” and repeat starting instructions.

IMPORTANT: Do not overload the generator. Also, do not overload individual panel receptacles. These outlets are protected against overload with push-to-reset or toggle type circuit breakers. If amperage rating of any circuit breaker is exceeded, that breaker opens and electrical output to that receptacle is lost. Read "Generator Loads" carefully.

3.6 — STOPPING THE GENERATOR

NOTE

 **NEVER start or stop the engine with electrical devices plugged in and turned on.**

1. Shut off all loads, then unplug the electrical loads from the generator's panel receptacles or extension cord.
2. Let the engine run at no-load for several minutes to stabilize the internal temperatures of the engine and generator.
3. See Figure 3-4. Rotate the PowerDial clockwise to the STOP position. This will shut down the engine and turn off the fuel flow by closing the fuel valve.

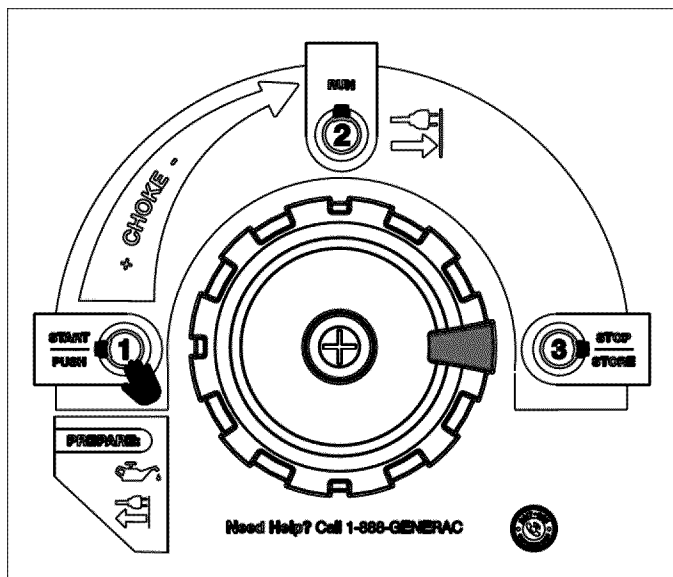



Figure 3-4. PowerDial STOP position

3.7 — RESTARTING THE GENERATOR

If the generator has cooled completely, use the starting procedures outlined in 3.4 or 3.5. However, if the generator is at or near operating temperature, use the following steps when restarting the unit.

 **Never start or stop engine with electrical devices plugged into the receptacles AND devices turned on.**

NOTE

The generator is shut off and the PowerDial is turned to the STOP position. Turning the PowerDial counterclockwise, past the RUN position, turns on the fuel again and permits use of the electric starter. The PowerDial MUST be turned from the STOP position to just past the RUN position to restart the fuel flow. Do not turn far. The choke is not required if the engine is hot.

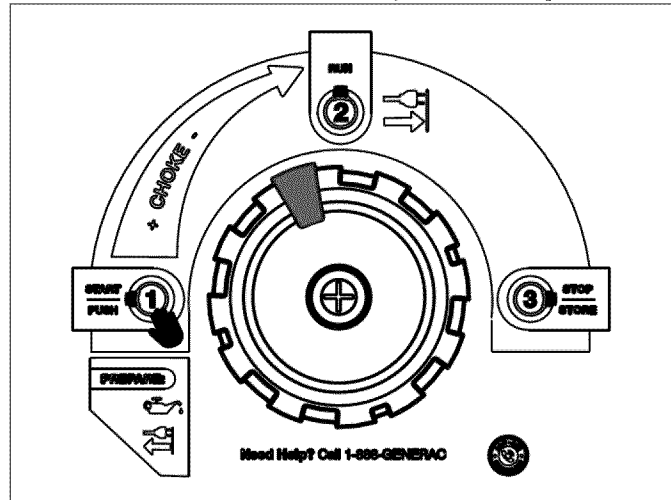

Figure 3-5. PowerDial in the hot restart position

1. See Figure 3-5. To restart a hot generator, turn the PowerDial counterclockwise, from the STOP position, until it is just past the RUN position. This will reopen the fuel valve and permit electric start or recoil starting.
2. Press the PowerDial button in this position to electric start. (7.0 kW only) or firmly grasp the recoil handle and pull slowly until increased resistance is felt. Pull rapidly up and away to pull start engine.
3. Then turn the PowerDial clockwise to the RUN position.

3.8 — LOW OIL LEVEL SHUTDOWN SYSTEM

The engine is equipped with a low oil level sensor that shuts down the engine automatically when the oil level drops below a specified level. If the engine shuts down by itself and the fuel tank has sufficient fuel, check engine oil level.

Section 4 *Maintenance*

4.1 — General Recommendations

The warranty of the generator does not cover items that have been subjected to operator abuse or negligence. To receive full value from the warranty, the operator must maintain the generator as instructed in this manual.

Some service procedures will be performed periodically to properly maintain the generator.

All service procedures in the Maintenance section of this manual should be made at the intervals indicated. Follow the intervals in the "Service Interval Table 4-1".

4.2 — Generator Cleaning

Generator cleaning consists of keeping the unit clean and dry. Operate and store the unit in a clean dry environment where it will not be exposed to excessive dust, dirt, moisture or any corrosive vapors. Cooling air slots in the generator must not become clogged with snow, leaves, or any other foreign material. Check the cleanliness of the generator frequently and clean when dust, dirt, oil, moisture or other foreign substances are visible on its exterior surface.

▲ CAUTION!



Never insert any object or tool through the air cooling slots, even if the engine is not running.

4.2.1 — Generator Cleaning

- Use a damp cloth to wipe exterior surfaces clean.
- A soft, bristle brush may be used to loosen caked on dirt, oil, etc.
- A vacuum cleaner may be used to pick up loose dirt and debris.
- Low pressure air (not to exceed 25 psi/1.72 bar) may be used to remove dirt. Inspect cooling air slots and openings on the generator. These openings must be kept clean and unobstructed.

NOTE:

DO NOT use a garden hose to clean generator. Water can enter the engine fuel system and cause problems. In addition, if water enters the generator through cooling air slots, some water will be retained in voids and crevices of the rotor and stator winding.

4.3 — Service Intervals

Follow the service interval table to perform scheduled maintenance. More frequent service is required when operating in adverse conditions as noted below.

Table 4-1: Service Intervals

OPERATION	INTERVAL FREQUENCY
Oil Level Check	Prior to every use/or every 24 hours of operation
Oil Change (break-in)	After initial 30 hours of operation
Oil Change	Every 100 hours of operation and/or annually
Spark Plug Replacement	Every 200 hours of operation and/or annually
Air Filter Service	Every 200 hours of operation and/or annually
Spark Arrestor Service	Annually
Valve Clearance Adjustment (break-in)	After 50 hours of operation
Valve Clearance Adjustment	Every 300 hours of operation
Fuel Filter Replacement	Every 500 hours of operation and/or annually
Battery Charging	Every 3 months or if starter will not turn engine
Battery Replacement	If it no longer accepts a charge
Storage	If not used for 30 days or more/ long term

4.3.1 — Engine Maintenance

⚠ DANGER!



When working on the generator, always disconnect spark plug wire from spark plug and keep wire away from spark plug.

4.3.2 — Oil Level Check

See the “Before Starting the Generator” section for information on Adding and checking the oil level. The oil level should be checked before each use, or at least every eight hours of operation. Keep the oil level maintained. See Figure 4-1 for the dipstick and oil fill location.

4.3.3 — Oil Change

Change the oil after the first 30 hours and every 100 hours thereafter. If running this unit under dirty or dusty conditions, or in extremely hot weather, change the oil more often.

⚠ CAUTION!



Hot oil may cause burns. Allow engine to cool before draining oil. Avoid prolonged or repeated skin exposure with used oil. Thoroughly wash exposed areas with soap.

Use the following instructions to change the oil after the engine cools down:

1. Clean area around oil drain plug. See Figure 4-1.
2. Remove oil drain plug from engine and oil fill plug to drain oil completely into a suitable container.
3. When oil has completely drained, install oil drain plug and tighten securely.
4. Fill engine with recommended oil. (See “Before Starting the Generator” for oil recommendations).
5. Fill to the upper level on the dipstick. See Figure 4-2.
6. Dispose of used oil at a proper collection center.

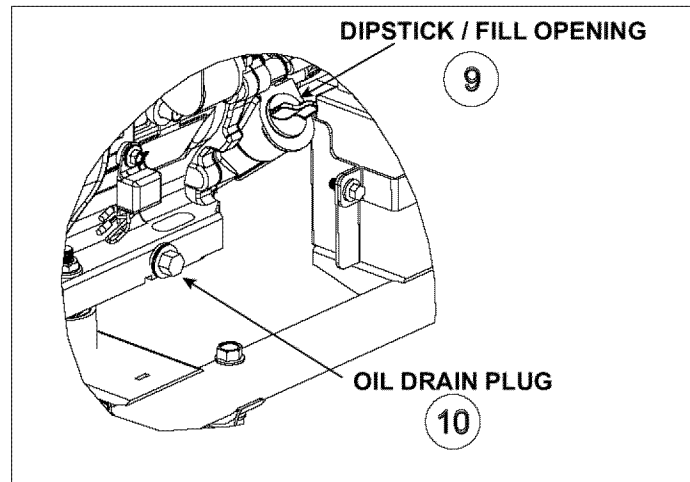

Figure 4-1. Oil Drain Plug

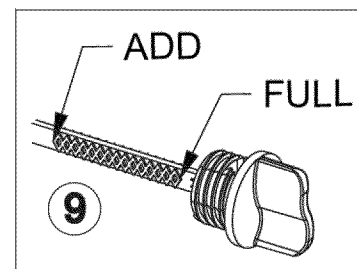

Figure 4-2. Oil Fill/Dipstick

4.3.4 — Spark Plug Replacement

Use a Champion N9YC spark plug or equivalent.
Replace the plug every 200 hours.

1. Stop the engine by turning the PowerDial to the STOP position. Allow the engine to cool.
2. Remove the spark plug boot from the plug and clean that area of the cylinder head. The spark plug is located on the side of the generator shown in Figure 4-3.
3. Use a 13/16 in. (21 mm) spark plug tool to remove the spark plug.
4. Set the new spark plug's gap to 0.028-0.031 in (0.70-0.80 mm). See Figure 4-4.
5. Install the correctly gapped spark plug into the cylinder head and torque to 18-21.6 ft/lbs/24.4-29.3 Nm.
6. Reconnect the spark plug wire.

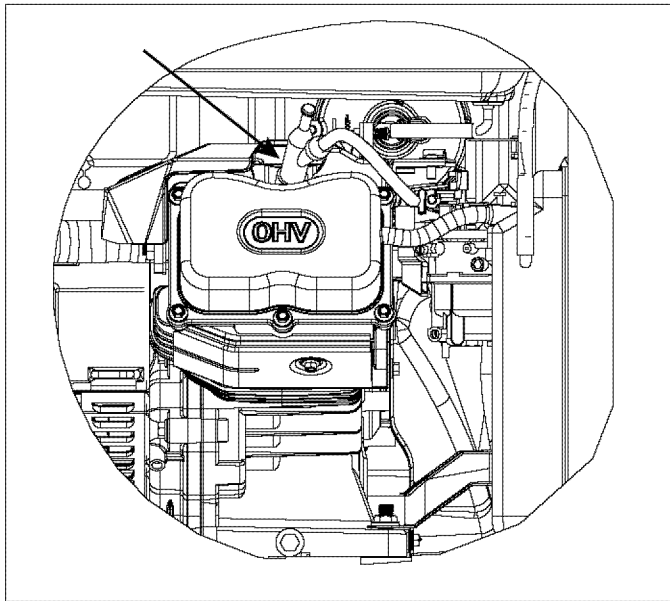

Figure 4-3. Spark Plug Location

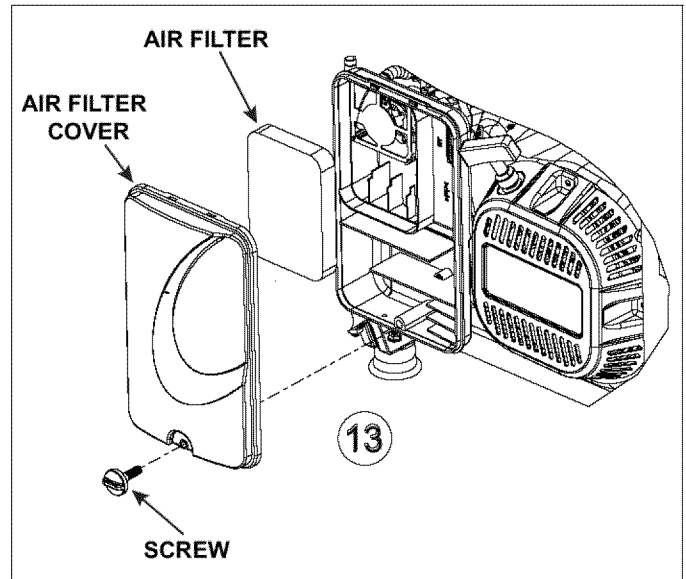

Figure 4-5. Air Filter

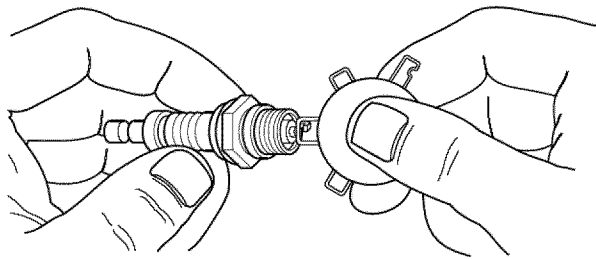

Figure 4-4. Spark Plug Gap

4.3.5 — Air Filter Service

The engine will not run properly and may be damaged if using a dirty air filter. Clean the air filter every 50 hours or annually (Figure 4-5). Clean or replace more often if operating under dusty conditions.

1. Remove air filter cover retaining screw and cover.
2. Wash in soapy water. Squeeze filter dry in clean cloth (DO NOT TWIST).
3. Clean air filter cover before re-installing it.
4. Tighten air filter cover screw securely.

NOTE:

To order a new air filter, please call 1-888-436-3722.

4.3.6 — Valve Clearance Adjustment

- Intake - 0.006 ± 0.0008 in. (0.15 ± 0.02 mm) (cold)
- Exhaust - 0.008 ± 0.0008 in. (0.20 ± 0.02 mm) (cold)
- After the first 50 hours of operation, check the valve clearance in the engine and adjust if necessary.

NOTE:

Important: If feeling uncomfortable about doing this procedure or the proper tools are not available, please take the generator to the nearest service center to have the valve clearance adjusted. This is a very important step to ensure longest life for the engine.

To check valve clearance:

1. Make sure the engine is at room temperature ($60 - 80$ °F/ $15.55 - 26.66$ °C).
2. Make sure that the spark plug wire(s) is removed from the spark plug and out of the way. Remove spark plug(s).
3. Remove the six screws attaching the valve cover(s).
4. Make sure the piston is at Top Dead Center (TDC) of its compression stroke (both valves closed). To get the piston at TDC, pull the recoil handle slowly while watching the piston through the spark plug hole. The piston should move up and down. The piston is at TDC when it is up as high as it can go.

5. Insert a 0.006 in (0.15 mm) feeler gauge, for intake clearance, between the intake rocker arm and valve stem. Insert a 0.008 in (0.20 mm) feeler gauge, for exhaust clearance, between the exhaust rocker arm and valve stem. Correct clearance is when a slight drag is felt when sliding the gauge back and forth. If the clearance is either excessively loose or tight the rocker arms will need adjusting.

To adjust valve clearance:

1. Hold the rocker arm pivot with a wrench and loosen the pivot lock nut (Figure 4-6).

NOTE:

The rocker arm jam nut must be held in place as the pivot ball stud is turned.

2. Loosen the rocker arm pivot and turn the rocker arm pivot to obtain the specified valve clearance. The desired clearance for intake and exhaust valves is the same.
3. Hold the rocker pivot with a wrench and tighten the lock nut to 2.25 - 3.15 ft/lbs (10 - 14 Nm).
4. Install new valve cover gasket.

NOTE:

Start all six screws before tightening or it will not be possible to get all the screws in place.

5. Re-attach the valve cover. Torque fasteners to 20-48 in/lbs / 2.3-5.4 Nm. Torque fasteners in a cross pattern.

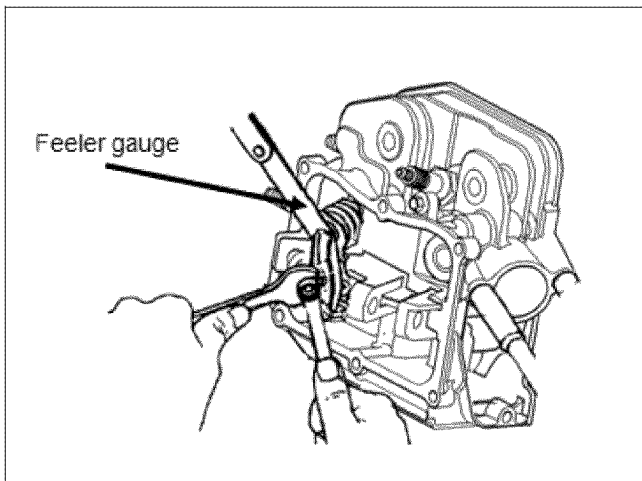

Figure 4-6. Valve Clearance Adjustment

6. Re-attach the spark plug boot to the spark plug.

4.3.7 — Fuel Filter Replacement

The fuel filter replacement should take place every 500 hours of operation and/or annually (Figure 4-7).

1. Turn the PowerDial to the STOP position. Allow the engine to cool.
2. Using a pliers, squeeze the clamp and slide the clamp away from the fuel filter fittings and remove the hose from fuel valve fitting. Clamps can be reused.
3. Remove the short hose from the fuel filter. Then remove the filter from the longer hose.
4. Place the new filter on the longer hose. The larger end of the filter (with the red dot) must face towards the fuel valve. Position the clamp on the filter fitting.
5. Place the short length of hose on the filter. Then the other end on the fuel valve.
6. Place both clamps back onto the fittings of the filter and fuel valve.

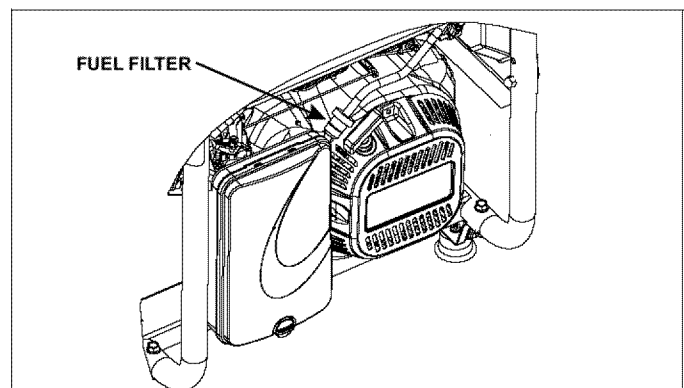

Figure 4-7. Fuel Filter Location

4.3.8 — Battery Charging (7.0 kW only)

The charging port is protected by a 1.50 Amp replaceable in-line fuse. If the charger is not recharging the battery, check the fuse. Replacement fuses can be obtained at your dealer.

1. The battery charger fuse is located behind the control panel as shown in Figure 4-8.

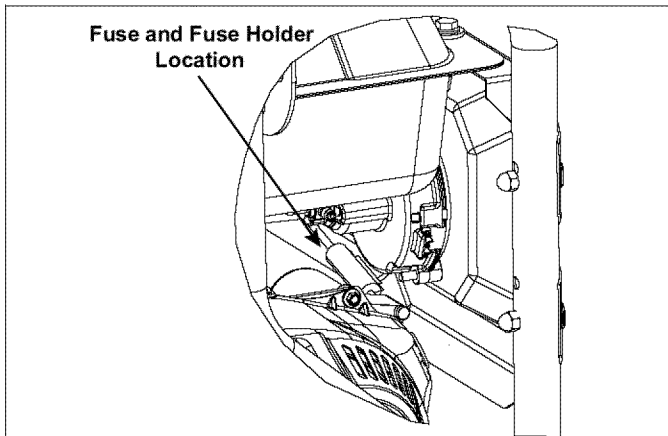

Figure 4-8. Battery Fuse Location

1. See Figure 4-9. The two halves of the fuse holder pull apart. Remove the broken fuse.
2. Install a new replacement fuse and push the halves of the fuse holder together.
3. Route all wires away from any engine components and secure them, as before, with the rubber coated clamp.

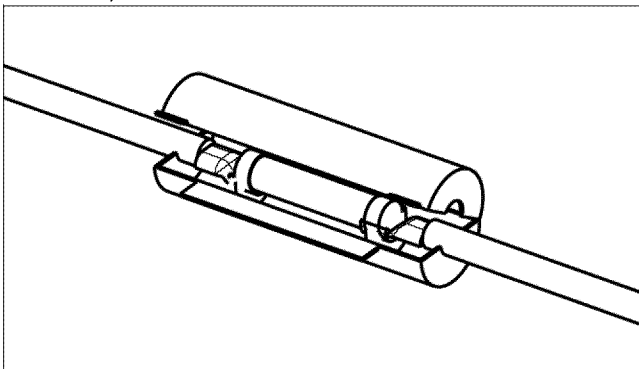

Figure 4-9. Battery Charger Fuse

⚠ DANGER!



Storage batteries give off explosive hydrogen gas while recharging. An explosive mixture will remain around the battery for a long time after it has been charged. The slightest spark can ignite the hydrogen and cause an explosion. Such an explosion can shatter the battery and cause blindness or other serious injury.



Do not permit smoking, open flame, sparks or any other source of heat around a battery. Wear protective goggles, rubber apron and rubber gloves when working around a battery. Battery electrolyte fluid is an extremely corrosive sulfuric acid solution that can cause severe burns. If spill occurs flush area with clear water immediately.

NOTE:

The battery shipped with the generator has been fully charged. A battery may lose some of its charge when not in use for prolonged periods of time. If the battery is unable to crank the engine, plug in the 12V charger included in the accessory box. **RUNNING THE GENERATOR DOES NOT CHARGE THE BATTERY.**

Use battery charger plug to keep the battery charged and ready for use. Battery charging should be done in a dry location.

1. Plug charger into "Battery Charger Input" jack (4), located on the control panel (Figure 2-5). Plug wall receptacle end of the battery charger into a 120 Volt AC wall outlet.
2. Unplug battery charger from wall outlet and control panel jack when generator is going to be in use.

NOTE:

Do not use the battery charger for more than 48 hours at one charge. Charge the battery at least once every 3 months.

4.3.9 — Battery Replacement (7.0 kW only)

When the battery will no longer accept a charge, replacement is necessary. The battery is needed to use the electric starter.

NOTE:

The battery shipped with the generator has been fully charged. A battery may lose some of its charge when not in use for prolonged periods of time. If the battery is unable to crank the engine, plug in the 12V charger included in the accessory box (see the Charging the Battery section). **RUNNING THE GENERATOR DOES NOT CHARGE THE BATTERY.**

The battery shipped with the generator has been provided fully charged. To replace the battery, see Figure 4-10.

1. Disconnect and remove the battery mounting hardware (8mm) and BLACK wire from the battery's NEGATIVE (-) terminal.
2. Move the red protective boot and disconnect the battery mounting hardware (8 mm) and RED wire from the battery's POSITIVE (+) terminal.
3. Remove the two screws and bracket from the battery tray. Remove the battery.
4. Place the new battery in the tray. Secure with the bracket and two mounting screws. Tighten screws securely.
5. Reconnecting the RED wire to the POSITIVE (+) terminal and the BLACK wire to the NEGATIVE (-) terminal.

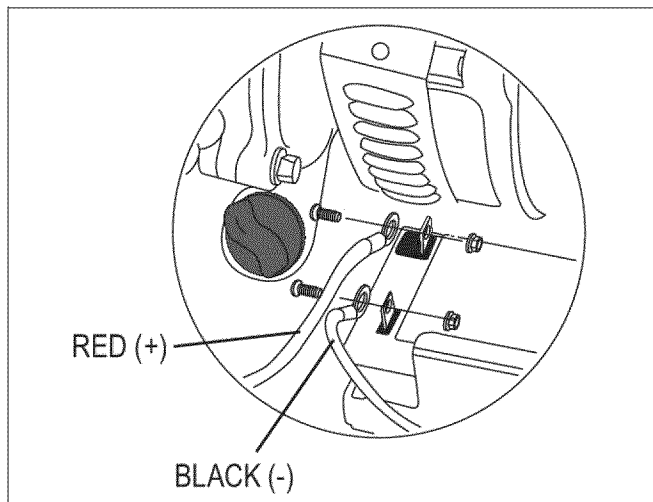

Figure 4-10. Battery Mounting Hardware

NOTE:

Your generator can still be operated using the recoil starter.

4.4 — Generator Storage

The unit should be started at least once every 30 days and be allowed to run at least 30 minutes. If this cannot be done and the unit must be stored for more than 30 days, use the following information as a guide to prepare it for storage.

⚠ DANGER!



Allow unit to cool entirely before storage.

4.4.1 — Long Term Storage

1. Treat the fuel with a commercially available fuel stabilizer. Operate the engine for 10-15 minutes to circulate treated fuel into the fuel lines and carburetor. The fuel may be left in the tank or drained into a suitable container.
2. Drain oil from crankcase. Refill with recommended grade oil.
3. Remove spark plug and pour about 1/2 oz (15 ml) of engine oil into the cylinder. Cover spark plug hole with rag. Pull the recoil starter several times to lubricate the piston rings and cylinder bore. A fogging agent can be used in place of oil.

⚠ CAUTION!



Avoid spray from spark plug hole when cranking engine.

4. Install and tighten spark plug. Do not connect spark plug wire.

NOTE:

Allow the unit to cool completely.

5. Clean the unit's outer surfaces. Check that cooling air slots and openings on the unit are open and unobstructed.
6. Store the unit in a clean, dry place.

4.4.2 — Other Storage Tips

- If possible, store the unit indoors and cover it to give protection from dust and dirt. **BE SURE TO TURN THE POWERDIAL TO THE STOP POSITION.**
- Cover the unit with a suitable protective cover that does not retain moisture.

⚠ DANGER!



NEVER cover the generator while engine and exhaust areas are warm.

Section 5 *Troubleshooting*

5.1 — Troubleshooting Guide

PROBLEM	CAUSE	CORRECTION
Engine is running, but no AC output is available.	<ol style="list-style-type: none"> 1. Circuit breaker is open. 2. Poor connection or defective cord set. 3. Connected device is bad. 4. Fault in generator. 	<ol style="list-style-type: none"> 1. Reset circuit breaker. 2. Check and repair. 3. Connect another device that is in good condition. 4. Contact Authorized Service Facility.
Engine runs well but bogs down when loads are connected.	<ol style="list-style-type: none"> 1. Short circuit in a connected load. 2. Generator is overloaded. 3. Engine speed is too slow. 4. Shorted generator circuit. 	<ol style="list-style-type: none"> 1. Disconnect shorted electrical load. 2. See "Generator Loads". 3. Contact Authorized Service Facility. 4. Contact Authorized Service Facility.
Engine will not start; or starts and runs rough.	<ol style="list-style-type: none"> 1. PowerDial is in the STOP position. 2. PowerDial is not fully in the RUN position. 3. Dirty air filter. 4. Dirty fuel filter. 5. Out of fuel. 6. Spark plug wire not connected to spark plug. 7. Bad spark plug. 8. Water in fuel. 9. Low oil level. 10. Excessive rich fuel mixture. 11. Intake valve stuck open or closed. 12. Engine has lost compression. 	<ol style="list-style-type: none"> 1. Turn PowerDial to the START position. 2. Turn PowerDial fully to the RUN position. 3. Clean or replace air filter. 4. Replace fuel filter. 5. Fill the fuel tank. 6. Connect wire to spark plug. 7. Replace spark plug. 8. Drain fuel tank and replace with fresh fuel. 9. Fill crankcase to proper level. 10. Contact Authorized Service Facility. 11. Contact Authorized Service Facility. 12. Contact Authorized Service Facility.
Engine shuts down during operation.	<ol style="list-style-type: none"> 1. Out of fuel. 2. Low oil level. 3. Dirty fuel filter. 4. Fault in engine. 	<ol style="list-style-type: none"> 1. Fill the fuel tank. 2. Fill crankcase to proper level. 3. Change fuel filter. 4. Contact Authorized Service Facility.
Engine lacks power.	<ol style="list-style-type: none"> 1. Load is too high. 2. Dirty air filter. 3. Dirty fuel filter. 4. Engine needs to be serviced. 	<ol style="list-style-type: none"> 1. Reduce load (see "Generator Loads"). 2. Clean or replace air filter. 3. Replace fuel filter. 4. Contact Authorized Service Facility.
Engine "hunts" or falters.	<ol style="list-style-type: none"> 1. Carburetor is running too rich or too lean. 2. Dirty fuel filter. 3. Governor out of adjustment? 	<ol style="list-style-type: none"> 1. Contact Authorized Service Facility. 2. Replace fuel filter. 3. Contact authorized dealer facility.

5.2 — Replacement Service Parts

Description	Part No.
Oil (quart)	0G0752
Spark Plug	0J00620106
Air Filter	0G84420151
Fuel Filter	0G9914
Battery	0G9449
Battery Fuse	0K3029

Part No. 0K6504 Rev E 06/25/14
© Generac Power Systems, Inc. All rights reserved
Specifications are subject to change without notice.
No reproduction allowed in any form without prior written
consent from Generac Power Systems, Inc.

Generac Power Systems, Inc.
S45 W29290 Hwy. 59
Waukesha, WI 53189
1-888-GENERAC (1-888-436-3722)
generac.com