

Use & Care Guide  
Manual de Uso y Cuidado  
English / Español

# Kenmore®



## Island Grill with Refrigerator

### Parrilla tipo isla con frigorífico

Models/Modelos: 139.20153510  
Items / Artículos: 640-08678222-4



P/N 3108226-Manual Rev 1 01/12  
Sears Brands Management Corporation  
Hoffman Estates, IL 60179 U.S.A.  
[www.kenmore.com](http://www.kenmore.com)  
[www.sears.com](http://www.sears.com)  
[www.kmart.com](http://www.kmart.com)



 **DANGER** 

If you smell gas:

1. Shut off gas to the appliance.
2. Extinguish any open flame.
3. Open lid.
4. If odor continues, keep away from the appliance and immediately call your gas supplier or your fire department.

 **WARNING** 

1. Do not store or use gasoline or other flammable liquids or vapors in the vicinity of this or any other appliance.
2. An LP cylinder not connected for use shall not be stored in the vicinity of this or any other appliance.



Call Grill Service Center For Help And Parts  
 If you have questions or need assistance during assembly, please call 1-800-482-0131. You will be speaking to a representative of the grill manufacturer and not a Sears employee. To order new parts call Sears at 1-800-4-MY-HOME.

Product Record  
**IMPORTANT:** Fill out the product record information below.

Model Number \_\_\_\_\_

Serial Number \_\_\_\_\_  
 See rating label on grill for serial number.

Date Purchased \_\_\_\_\_

 **CAUTION** 

For residential use only. Do not use for commercial cooking.

Installation Safety Precautions

- Use grill, as purchased, only with LP (propane) gas and the regulator/valve assembly supplied. A conversion kit must be purchased for use with natural gas.
- Grill installation must conform with local codes, or in their absence of local codes, with either the National Fuel Gas Code, ANSI Z223.1/ NFPA 54, Natural Gas and Propane Installation Code, CSA B149.1, or Propane Storage and Handling Code, B149.2, or the Standard for Recreational Vehicles, ANSI A 119.2/NFPA 1192, and CSA Z240 RV Series, Recreational Vehicle Code, as applicable.
- All electrical accessories (such as rotisserie) must be electrically grounded in accordance with local codes, or National Electrical Code, ANSI / NFPA 70 or Canadian Electrical Code, CSA C22.1. Keep any electrical cords and/or fuel supply hoses away from any hot surfaces.
- This grill is safety certified for use in the United States and/or Canada only. Do not modify for use in any other location. Modification will result in a safety hazard.



**IMPORTANT:** This grill is intended for outdoor use and is not intended to be installed in or on recreational vehicles or boats.

**NOTE TO INSTALLER:** Leave this Use & Care Guide with the customer after delivery and/or installation.



**NOTE TO CONSUMER:** Leave this Use & Care Guide in a convenient place for future reference.

Safety Symbols



The symbols and boxes shown below explain what each heading means. Read and follow all of the messages found throughout the manual.

 **DANGER** 

**DANGER:** Indicates an imminently hazardous situation which, if not avoided, will result in death or serious injury.

 **WARNING** 

**WARNING:** Indicates an potentially hazardous situation which, if not avoided, could result in death or serious injury.

 **CAUTION** 

**CAUTION:** Indicates a potentially hazardous situation or unsafe practice which, if not avoided, may result in minor or moderate injury.

## TABLE OF CONTENTS

For Your Safety . . . . .	2
Grill Service Center. . . . .	2
Product Record Information . . . . .	2
Safety Symbols. . . . .	2
Installation Safety Precautions . . . . .	2
Kenmore Grill Warranty . . . . .	3-4
Use and Care . . . . .	4-11
Natural Gas Conversion Kit . . . . .	12
Parts List And Parts Diagram. . . . .	13-17
Assembly . . . . .	18-22
Troubleshooting For Grill. . . . .	23-25
Refrigerator Safety Information And Instruction. . . . .	26-27
Care And Maintenance. . . . .	28
Troubleshooting For Refrigerator. . . . .	29
Technical Data and Wiring Diagram. . . . .	30

### Repair Protection Agreements

Congratulations on making a smart purchase. Your new Kenmore ®product is designed and manufactured for years of dependable operation. But like all products, it may require repair from time to time. That's when having a Repair Protection Agreement can save you money and aggravation. Purchase a Repair Protection Agreement now and protect yourself from unexpected hassle and expense. Here's what the Repair Protection Agreement includes:

- Expert service by our 10,000 professional repair specialists
- Unlimited service and no charge for parts and labor on all covered repairs
- Product replacement up to \$1500 if your covered product can't be fixed
- Discount of 25% from regular price of service and related installed parts not covered by the agreement; also, 25% off regular price of preventive maintenance check
- Fast help by phone – we call it Rapid Resolution – phone support from a Sears representative. Think of us as a “talking owner’s manual.”

Once you purchase the Repair Protection Agreement, a simple phone call is all that it takes for you to schedule service. You can call anytime day or night, or schedule a service appointment online.

The Repair Protection Agreement is a risk-free purchase. If you cancel for any reason during the product warranty period, we will provide a full refund. Or, a prorated refund anytime after the product warranty period expires. Purchase your Repair Protection Agreement today!

Some limitations and exclusions apply.

For prices and additional information call 1-800-827-6655.  
Sears Installation Service

For Sears professional installation of home appliances, garage door openers, water heaters, and other major home items, in the U.S.A. call 1-800-4-MY-HOME®

## WARRANTY

### KENMORE LIMITED WARRANTY

WITH PROOF OF SALE, the following warranty coverage applies when this appliance is correctly installed, operated and maintained according to all supplied instructions.

FOR ONE YEAR from the date of sale this appliance is warranted against defects in material or workmanship. A defective appliance will receive free repair or replacement at option of seller.

FOR TEN YEARS from the date of sale, any stainless steel burner that rusts through or burns through will be replaced free of charge. After the first year from the sale date you are responsible for the labor cost of part installation.

For warranty coverage details to obtain free repair or replacement, visit the web page:[www.kenmore.com/warranty](http://www.kenmore.com/warranty)

All warranty coverage excludes ignitor batteries and grill part paint loss, discoloration or surface rusting, which are either expendable parts that can wear out from normal use within the warranty period, or are conditions that can be the result of normal use, accident or improper maintenance.

All warranty coverage applies is void if this appliance is ever used for other than private household purposes.

**This warranty covers ONLY defects in material and workmanship, and will NOT pay for:**

1. Expendable items that can wear out from normal use within the warranty period, including but not limited to batteries, screw-in base light bulbs and surface coatings or finishes.
2. A service technician to clean or maintain this appliance, or to instruct the user in correct appliance installation, operation and maintenance.
3. Service calls to correct appliance installation not performed by Sears authorized service agents, or to repair problems with house fuses, circuit breakers, house wiring, and plumbing or gas supply systems resulting from such installation.
4. Damage to or failure of this appliance resulting from installation not performed by Sears authorized service agents including installation that was not in accord with electrical, gas or plumbing codes.
5. Damage to or failure of this appliance, including discoloration or surface rust, if it is not correctly operated and maintained according to all supplied instructions.
6. Damage to or failure of this appliance, including discoloration or surface rust, resulting from accident, alteration, abuse, misuse or use for other than its intended purpose.
7. Damage to or failure of this appliance, including discoloration or surface rust, caused by the use of detergents, cleaners, chemicals or utensils other than those recommended in all instructions supplied with the product.
8. Damage to or failure of this appliance resulting from natural or other catastrophe, such as flood, fire or storm.
9. Damage to or failure of parts or systems resulting from unauthorized modifications made to this appliance.
10. Service to an appliance if the model and serial plate is missing, altered, or cannot easily be determined to have the appropriate certification logo.

### Disclaimer of implied warranties; limitation of remedies

Customer's sole and exclusive remedy under this limited warranty shall be product repair or replacement as provided herein. Implied warranties, including warranties of merchantability or fitness for a particular purpose, are limited to one year on the appliance and ten years on the burners, or the shortest period allowed by law. Seller shall not be liable for incidental or consequential damages. Some states and provinces do not allow the exclusion or limitation of incidental or consequential damages, or limitation on the duration of implied warranties of merchantability or fitness, so these exclusions or limitations may not apply to you.

This warranty applies only while this appliance is used in the United States.

This warranty gives you specific legal rights, and you may also have other rights which vary from state to state.

Sears Brands Management Corporation, Hoffman Estates, IL 60179

## USE AND CARE

- Turn OFF all control knobs and LP tank valve. Turn coupling nut counterclockwise by hand only - do not use tools to disconnect. Lift LP tank wire upward off of LP tank collar, then lift LP tank up and off of support bracket. Place the dust cap on cylinder valve outlet whenever the cylinder is not in use. Only install the type of the dust cap of the cylinder valve outlet that is provided with the cylinder valve. Other types of caps or plugs may result in leakage of propane.
- Failure to use safety cap as directed may result in serious personal injury and/or property damage.

### LP Tank Valve

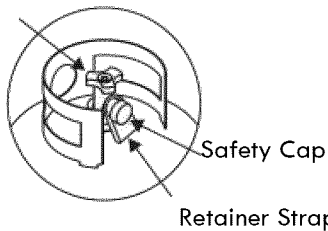

- A disconnected LP tank in storage or being transported must have a safety cap installed (as shown). Do not store an LP tank in enclosed spaces such as a carport, garage, porch, covered patio or other building. Never leave an LP tank inside a vehicle which may become overheated by the sun.
- Do not store an LP tank in an area where children play.

### LP (Liquefied Petroleum Gas)

- LP gas is nontoxic, odorless and colorless when produced. For Your Safety, LP gas has been given an odor (similar to rotten cabbage) so that it can be smelled.
- LP gas is highly flammable and may ignite unexpectedly when mixed with air.

### LP Cylinder Filling

- Use only licensed and experienced dealers.
- LP dealer must purge new cylinder before filling.
- Dealer should NEVER fill LP cylinder more than 80% of LP cylinder volume. Volume of propane in cylinder will vary by temperature.
- A frosty regulator indicates gas overfill. Immediately close LP cylinder valve and call local LP gas dealer for assistance.
- Do not release liquid propane (LP) gas into the atmosphere. This is a hazardous practice.
- To remove gas from LP cylinder, contact an LP dealer or call a local fire department for assistance. Check the telephone directory under "Gas Companies" for nearest certified LP dealers.

### LP Cylinder

- The LP cylinder used with your grill must meet the following requirements:
- Use LP cylinders only with these required measurements: 12" (30.5cm) (diameter) x 18" (45.7 cm) (tall) with 20 lb. (9 kg.) capacity maximum.
- LP cylinders must be constructed and marked in accordance with specifications for LP cylinders of the U.S. Department of Transportation (DOT) or for Canada, CAN/CSA-B339, cylinders, spheres and tubes for transportation of dangerous goods. Transport Canada (TC). See LP cylinder collar for marking.
- LP cylinder valve must have:
- Type 1 outlet compatible with regulator or grill.
- Safety relief valve.
- UL listed Overfill Protection Hand Wheel Device (OPD). This OPD safety feature is identified by a unique triangular hand wheel. Use only LP cylinders equipped with this type of valve.
- LP cylinder must be arranged for vapor withdrawal and include collar to protect LP cylinder valve. Always keep LP cylinders in upright position during use, transit or storage.

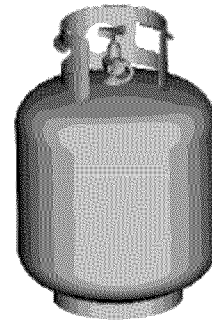

LP cylinder in upright position for vapor withdrawal

- (a) Do not store a space LP-gas cylinder under or near this appliance.
- (b) Never fill the cylinder beyond 80 percent full.
- (c) If the information in "(a)" and "(b)" is not followed exactly, a fire causing death or serious injury may occur.



**LP Tank Exchange**

- Many retailers that sell grills offer you the option of replacing your empty LP tank through an exchange service. Use only those reputable exchange companies that inspect, precision fill, test and certify their cylinders. Exchange your tank only for an OPD safety feature-equipped tank as described in the "LP Tank" section of this manual.
- Always keep new and exchanged LP tanks in upright position during use, transit or storage.
- Leak test new and exchanged LP tanks BEFORE connecting to grill.

**LP Tank Leak Test**

For your safety

- Leak test must be repeated each time LP tank is exchanged or refilled.
- Do not smoke during leak test.
- Do not use an open flame to check for gas leaks.
- Grill must be leak tested outdoors in a well-ventilated area, away from ignition sources such as gas fired or electrical appliances. During leak test, keep grill away from open flames or sparks.
- Use a clean paintbrush and a 50/50 mild soap and water solution. Brush soapy solution onto areas indicated by arrows in figure below. Leaks are indicated by growing bubbles.

	WARNING	
<p><b>If "growing" bubbles appear do not use or move the LP tank. Contact an LP gas supplier or your fire department!</b></p>		

▲ Do not use household cleaning agents. Damage to gas train components (valve/hose/regulator) can result.

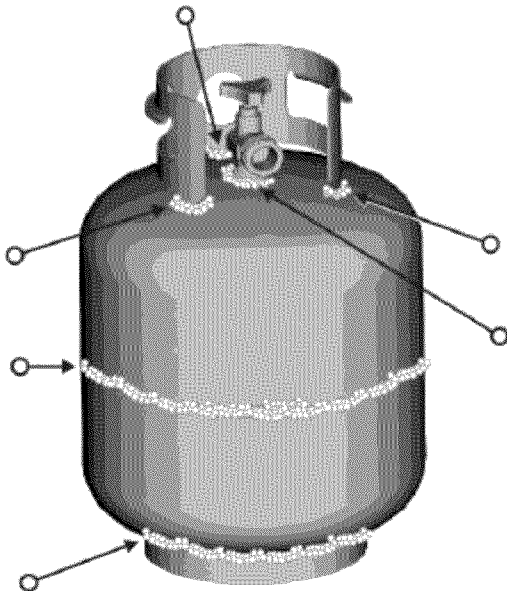

**Connecting Regulator To The LP Tank**

1. LP tank must be properly secured onto grill. (Refer to assembly section.)
2. Turn all control knobs to the OFF position.
3. Turn LP tank OFF by turning OPD hand wheel clockwise to a full stop.
4. Remove the protective cap from LP tank valve. Always use cap and strap supplied with valve.

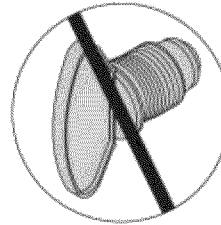
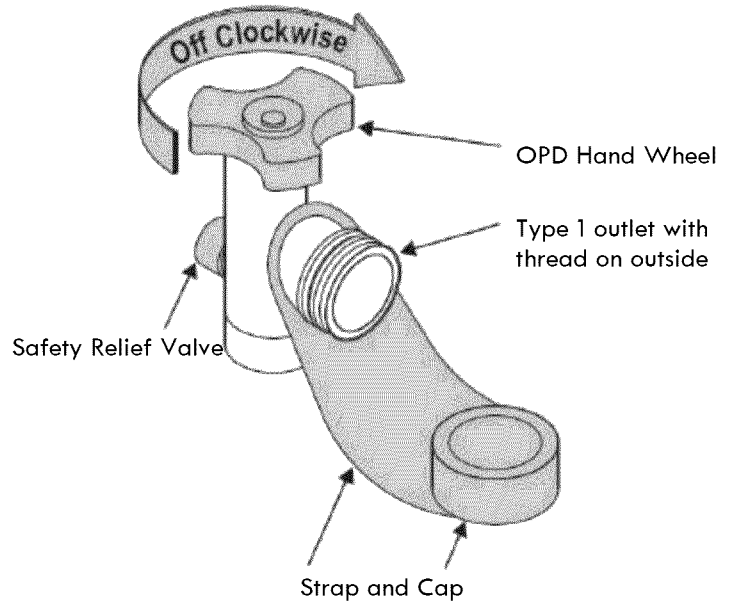

Do not insert a POL transport plug (plastic part with external threads) into the Type 1 tank valve outlet . It will defeat the Safety Relief Valve feature.

5. Hold regulator and insert nipple into LP tank valve. Hand-tighten the coupling nut, holding regulator in a straight line with LP tank valve so as not to crossthread the connection.

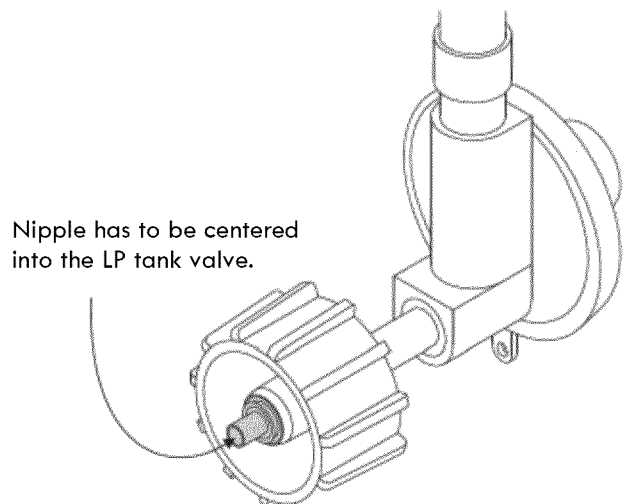

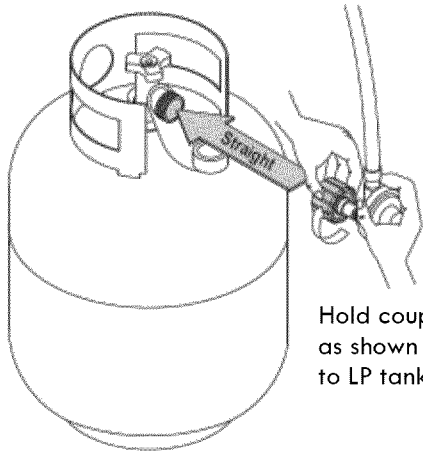

Hold coupling nut and regulator as shown for proper connection to LP tank valve.

- Turn the coupling nut clockwise and tighten to a full stop. The regulator will seal on the back-check feature in the LP tank valve, resulting in some resistance. An additional one-half to three-quarters turn is required to complete the connection. Tighten by hand only – do not use tools.

**NOTE:**

If you cannot complete the connection, disconnect regulator and repeat steps 5 and 6. If you are still unable to complete the connection, do not use this regulator! Call 1-800-482-0131 for assistance.

	<b>DANGER</b>	
<ul style="list-style-type: none"> <li>Do not insert any tool or foreign object into the valve outlet or safety relief valve. You may damage the valve and cause a leak. Leaking propane may result in explosion, fire, severe personal injury, or death.</li> </ul>		

	<b>WARNING</b>	
<ul style="list-style-type: none"> <li>Outdoor gas appliance is not intended to be installed in or on a boat.</li> <li>Outdoor gas appliance is not intended to be installed in or on an RV.</li> <li>Never attempt to attach this grill to the self-contained LP gas system of a camper trailer or motor home.</li> <li>Do not use grill until leak-tested.</li> <li>If a leak is detected at any time, STOP and call the fire department.</li> <li>If you cannot stop a gas leak, immediately close LP cylinder valve and call LP gas supplier or your fire department!</li> </ul>		

**Leak Testing Valves, Hose and Regulator**

- Turn all grill control knobs to OFF.
- Be sure regulator is tightly connected to LP tank.
- Completely open LP tank valve by turning OPD hand wheel counterclockwise. If you hear a rushing sound, turn gas off immediately. There is a major leak at the connection. Correct before proceeding by calling Sears for replacement parts at 1-800-4-MY-HOME®.
- Brush soapy solution onto areas where bubbles are shown in picture below:

▲ Never remove threaded orifice at end of valve.

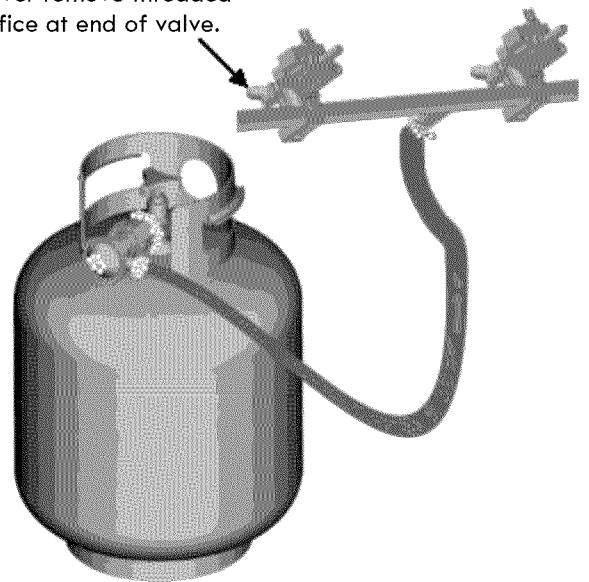

- If “growing” bubbles appear, there is a leak. Close LP tank valve immediately and retighten connections. If leaks cannot be stopped do not try to repair. Call Sears for replacement parts at 1-800-4-MY-HOME®.
- Always close LP tank valve after performing leak test by turning hand wheel clockwise.



## WARNING



### For Safe Use of Your Grill and to Avoid Serious Injury:

- Do not let children operate or play near grill.
- Keep grill area clear and free from materials that burn.
- Do not block holes in sides or back of grill.
- Check burner flames regularly.
- Use grill only in well-ventilated space. **NEVER** use in enclosed space such as carport, garage, porch, covered patio, or under an overhead structure of any kind.
- Do not use charcoal or ceramic briquets in a gas grill. (Unless briquets are supplied with your grill.)
- Use grill at least 3 ft. from any wall or surface. Maintain 10 ft. clearance to objects that can catch fire, or to sources of ignition such as pilot lights on water heaters, live electrical appliances, etc.

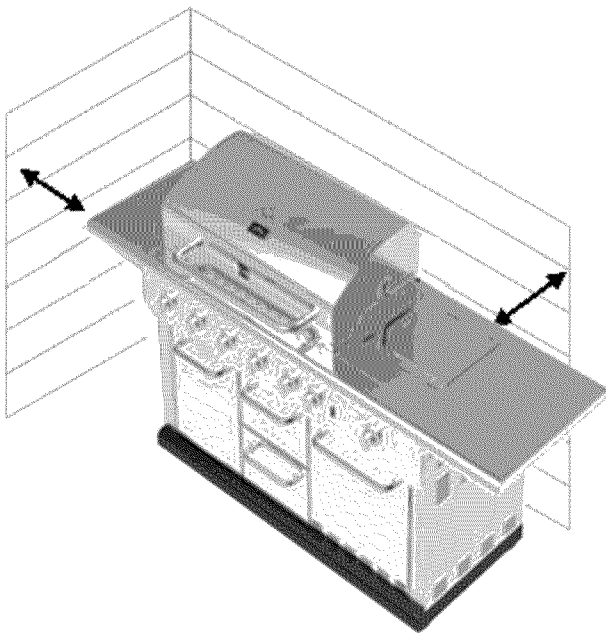

- **Apartment Dwellers:**  
Check with management to learn the requirements and fire codes for using an LP gas grill in your apartment complex. If allowed, use outside on the ground floor with a three (3) foot clearance from walls or rails. Do not use on or under balconies.
- **NEVER** attempt to light burner with lid closed. A buildup of non-ignited gas inside a closed grill is hazardous.
- Never operate grill with LP cylinder out of correct position specified in assembly instructions.
- Always close LP cylinder valve and remove coupling nut before moving LP cylinder from specified operation position.

### Safety Tips

- ▲ Before opening LP cylinder valve, check the coupling nut for tightness.
- ▲ When grill is not in use, turn off all control knobs and LP cylinder valve.
- ▲ Never move grill while in operation or still hot.
- ▲ Use long-handled barbecue utensils and oven mitts to avoid burns and splatters.
- ▲ Maximum load for side burner and side shelf is 10 lbs.
- ▲ The grease tray must be inserted into grill and emptied after each use. Do not remove grease tray until grill has completely cooled.
- ▲ Clean grill often, preferably after each cookout. If a bristle brush is used to clean any of the grill cooking surfaces, ensure no loose bristles remain on cooking surfaces prior to grilling. It is not recommended to clean cooking surfaces while grill is hot.
- ▲ If you notice grease or other hot material dripping from grill onto valve, hose or regulator, turn off gas supply at once. Determine the cause, correct it, then clean and inspect valve, hose and regulator before continuing. Perform a leak test.
- ▲ Keep ventilation openings in cylinder enclosure (grill cart) free and clear of debris.
- ▲ Do not store objects or materials inside the grill cart enclosure that would block the flow of combustion air to the underside of either the control panel or the firebox bowl.
- ▲ The regulator may make a humming or whistling noise during operation. This will not affect safety or use of grill.
- ▲ If you have a grill problem see the "Troubleshooting Section".
- ▲ If the regulator frosts, turn off grill and LP cylinder valve immediately. This indicates a problem with the cylinder and it should not be used on any product. Return to supplier!



## CAUTION



- **Putting out grease fires by closing the lid is not possible. Grills are well ventilated for safety reasons.**
- **Do not use water on a grease fire. Personal injury may result. If a grease fire develops, turn knobs and LP cylinder off.**
- **Do not leave grill unattended while preheating or burning off food residue on HI. If grill has not been regularly cleaned, a grease fire can occur that may damage the product.**

### Ignitor Lighting the Grill

1. Open lid during lighting.
2. Open LP cylinder valve or natural gas valve.
3. Push any burner control knob in and turn the knob to the left to "HI" position. You will hear a clicking sound from all the burners. Keep pressing the knob until the burner is lit.

4. If ignition does not occur in 5 seconds, turn the burner control off, wait 5 minutes for gas to clear away, and repeat step 3.
  5. To light other burners, repeat step 3.
- NOTE: If ignitor does not work, follow Match Lighting instructions.

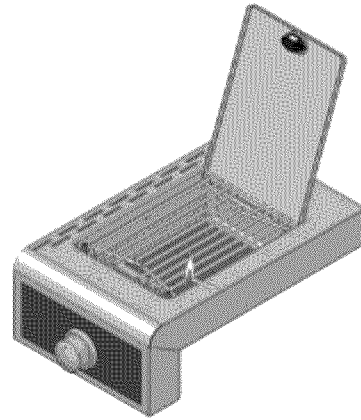

#### Burner Flame Check

- Remove cooking grates and heat diffusers. Light burners, rotate knobs from HIGH to LOW. You should see a smaller flame in LOW position than seen on HIGH. Perform burner flame check on sideburner, also. Always check flame prior to each use.

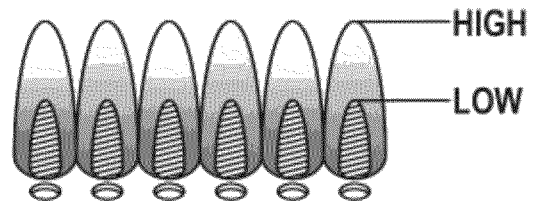

#### Turning Grill Off

- Turn all knobs to position. Turn LP cylinder off by turning hand-wheel clockwise to a full stop.

#### Ignitor Check

- Turn gas off at LP cylinder. Push the control knob in and turn the knob to the left to "HI" position. "Clicking" should be heard and spark seen each time between collector box or burner and electrode. See "Troubleshooting" if no click or spark.

#### Valve Check

- Important: Make sure gas is off at LP cylinder before checking valves. Knobs lock in OFF position. To check valves, first push in knobs and release, knobs should spring back. If knobs do not spring back, replace valve assembly before using grill. Turn knobs to LOW position then turn back to OFF position. Valves should turn smoothly.

#### Hose Check

- Before each use, check to see if hoses are cut or worn. Replace damaged hoses before using grill. Use only identical replacement part valve/hose/regulator as specified in the Parts List of this Use and Care Guide.

#### General Grill Cleaning

- Do not mistake brown or black accumulation of grease and smoke for paint. Interiors of gas grills are not painted at the factory (and should never be painted). Apply a strong solution of detergent and water or use a grill cleaner with scrub brush on insides of grill lid and bottom. Rinse and allow to completely air dry. Do not apply a caustic grill/oven cleaner to painted surfaces.
- Plastic parts: Wash with warm soapy water and wipe dry.

## WARNING

**Turn controls and gas source or tank OFF when not in use.**

## CAUTION

**If ignition does not occur in 5 seconds, turn the burner control off, wait 5 minutes, and repeat the lighting procedure. DO NOT leave burner control knob in ON position if burner does not light. If the burner does not ignite with the valve open, gas will continue to flow out of the burner and could accidentally ignite with risk of injury.**

#### Match-Lighting

- ▲ Do not lean over grill while lighting.
1. Open lid during lighting.
  2. Place match into match holder (hanging from chain attached to inside of left grill door). Light match, place into the firebox.
  3. Push in and turn right knob to HIGH position. Be sure burner lights and stays lit.
  4. Light other burners by pushing knob in and turning to HI position.

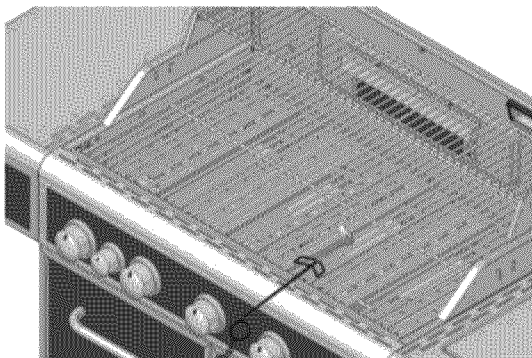

#### Side burner Match Lighting

1. Open side burner lid. Turn on gas at LP cylinder.
2. Place lit match near burner.
3. Turn side burner knob to HI. Be sure burner lights and stays lit.



Do not use citrisol, abrasive cleaners, degreasers or a concentrated grill cleaner on plastic parts. Damage to and failure of parts can result.

- Porcelain surfaces: Because of glass-like composition, most residue can be wiped away with baking soda/water solution or specially formulated cleaner. Use nonabrasive scouring powder for stubborn stains.
- Painted surfaces: Wash with mild detergent or nonabrasive cleaner and warm soapy water. Wipe dry with a soft nonabrasive cloth.
- Stainless steel surfaces: To maintain your grill's high quality appearance, wash with mild detergent and warm soapy water and wipe dry with a soft cloth after each use. Baked-on grease deposits may require the use of an abrasive plastic cleaning pad. Use only in direction of brushed finish to avoid damage. Do not use abrasive pad on areas with graphics.
- Cooking surfaces: If a bristle brush is used to clean any of the grill cooking surfaces, ensure no loose bristles remain on cooking surfaces prior to grilling. It is not recommended to clean cooking surfaces while grill is hot.
- Grease Tray and Cup: Regularly clean the grease drippings from the Grease Tray and Grease Cup. When the grill has completely cooled down after use, remove the cup from the tray and slide the tray out of the grill. Clean the grease drippings from the cup and tray surfaces by washing with mild detergent or nonabrasive cleaner and warm soapy water. Wipe dry with a soft nonabrasive cloth. Slide the tray back into the grill and replace the cup back into the tray before using the grill again.

#### Drawer Removal and Replacement

Remove the two center drawers to clean grill interior surfaces as described in the procedure below.

**CAUTION:** Be extremely careful of hand and finger placement when removing or replacing drawers. Drawer and slider edges can cut exposed skin. Wear protective gloves when removing or replacing drawers.

1. Pull the top drawer out as far as it will go until it comes to a stop.
2. On the drawer sliders, press the right release lever down and the left release lever up at the same time. See Figure below.



3. CAREFULLY slide the drawer back about an inch. Now grasp the drawer by the handle with both hands and pull it all the way out of the grill.
4. Repeat the three previous steps for the bottom drawer.
5. To replace each drawer, insert the ends of the drawer sliders into the ends of the drawer brackets on the grill. Push drawer in all the way until it closes.

#### Storing Your Grill

- Clean cooking grates.
- Store in dry location.
- When LP cylinder is connected to grill, store outdoors in a wellventilated space and out of reach of children.
- Cover grill if stored outdoors. Choose from a variety of grill covers offered by manufacturer.
- Store grill indoors ONLY if LP cylinder is turned off and disconnected, removed from grill and stored outdoors.
- When removing grill from storage, follow "Cleaning the Burner Assembly" instructions before starting grill.

#### Cleaning the Burner Assembly

Follow these instructions to clean and/or replace parts of burner assembly or if you have trouble igniting grill.

1. Turn gas off at control knobs and LP cylinder.
2. Remove cooking grates and heat diffusers.
3. Remove cotter pins from rear of burners.
4. Carefully lift each burner up and away from valve openings.

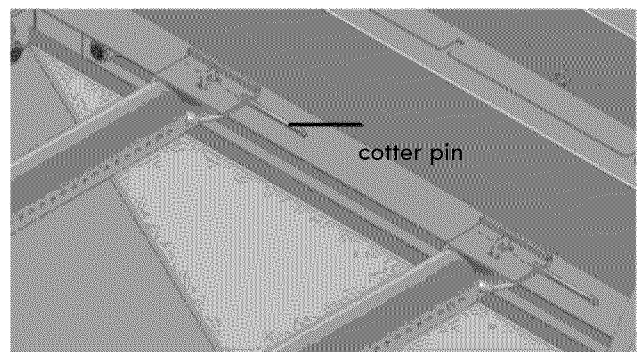

### SPIDER ALERT!

#### SPIDER AND WEBS INSIDE BURNER TUBE

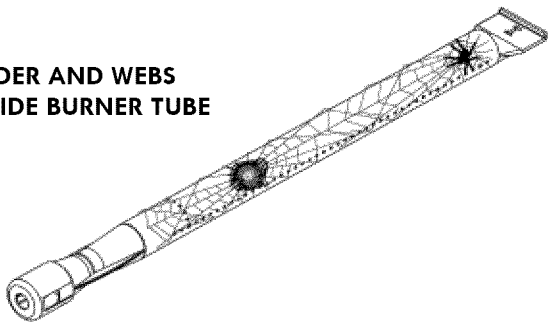

If you notice that your grill is getting hard to light or that The flame isn't as strong as it should be, take the time to check and clean the burner tubes.

Spiders or small insects have been known to create "flashback" problems. The spiders spin webs, build nests and lay eggs in the grill's burner tubes obstructing the flow of gas to the burner. The backed-up gas can ignite in the burner tube behind the control panel. This is known as a flashback and it can damage your grill and even cause injury.

To prevent flashbacks and ensure good performance the burner and burner tube assembly should be removed from the grill and cleaned before use whenever the grill has been idle for an extended period.

We suggest three ways to clean the burner tubes. Use the one easiest for you.

(A) Bend a stiff wire (a light weight coat hanger works well) into a small hook. Run the hook through each burner tube several times.



(B) Use a narrow bottle brush with a flexible handle (do not use a brass wire brush), run the brush through each burner tube several times.

(C) Wear eye protection: Use an air hose to force air into the burner tube and out the burner ports. Check each port to make sure air comes out each hole.

5. Wire brush entire outer surface of burner to remove food residue and dirt.
6. Clean any blocked ports with a stiff wire such as an open paper clip.
7. Check burner for damage, due to normal wear and corrosion some holes may become enlarged. If any large cracks or holes are found replace burner.

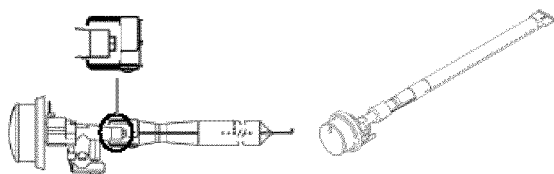

Correct burner-to-valve engagement

#### Indirect Cooking

Poultry and large cuts of meat cook slowly to perfection on the grill by indirect heat. Place food over unlit burner(s); the heat from lit burners circulates gently throughout the grill, cooking meat or poultry without the touch of a direct flame.

This method greatly reduces flare-ups when cooking extra fatty cuts because there is no direct flame to ignite the fats and juices that drip during cooking.

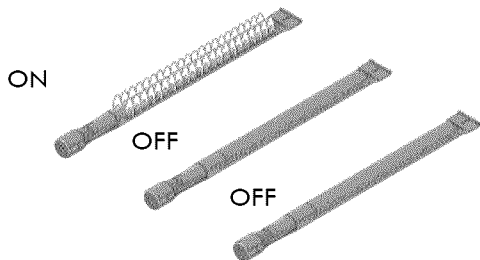

#### 1 Burner Cooking

Cook with direct or indirect heat.  
Best for smaller meals or foods.  
Consumes less fuel.

#### Indirect Cooking Instructions

- Always cook with the lid closed.
- Due to weather conditions, cooking times may vary. During cold and windy conditions the temperature setting may need to be increased to insure sufficient cooking temperatures.
- Place food over unlit burner(s)

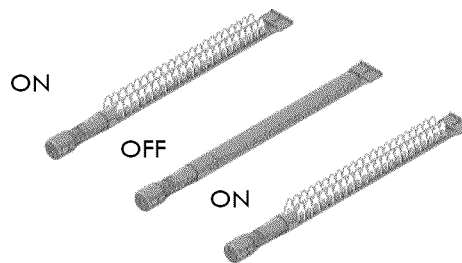

#### 2 Burner Cooking

Great indirect cooking on low.  
Produces slow, even heating.  
Ideal for slow roasting and baking.

#### Food Safety

Food safety is a very important part of enjoying the outdoor cooking experience. To keep food safe from harmful bacteria, follow these four basic steps:

**Clean:** Wash hands, utensils, and surfaces with hot soapy water before and after handling raw meat and poultry.

**Separate:** Separate raw meats and poultry from ready-to-eat foods to avoid cross contamination. Use a clean platter and utensils when removing cooked foods.

**Cook:** Cook meat and poultry thoroughly to kill bacteria. Use a thermometer to ensure proper internal food temperatures.

**Chill:** Refrigerate prepared foods and leftovers promptly.

For more information call: USDA Meat and Poultry Hotline at 1-800-535-4555 (In Washington, DC (202) 720-3333, 10:00 am-4:00 pm EST).

#### How To Tell If Meat Is Grilled Thoroughly

- Meat and poultry cooked on a grill often browns very fast on the outside. Use a meat thermometer to be sure food has reached a safe internal temperature, and cut into food to check for visual signs of doneness.
- Whole poultry should reach 180° F; breasts, 170° F. Juices should run clear and flesh should not be pink.
- Hamburgers made of any ground meat or poultry should reach 160° F, and be brown in the middle with no pink juices. Beef, veal and lamb steaks, roasts and chops can be cooked to 145° F. All cuts of pork should reach 160° F.
- NEVER partially grill meat or poultry and finish cooking later. Cook food completely to destroy harmful bacteria.
- When reheating takeout foods or fully cooked meats like hot dogs, grill to 165° F, or until steaming hot.

**WARNING:** To ensure that it is safe to eat, food must be cooked to the minimum internal temperatures listed in the table below.

USDA* Recommended Safe Minimum Internal Temperatures	
Beef, Veal, Lamb and Pork – Whole Cuts**	145° F
Fish	145° F
Beef, Veal, Lamb and Pork – Ground	160° F
Egg Dishes	160° F
Turkey, Chicken & Duck – Whole, Pieces & Ground	165° F

\* United States Department of Agriculture

\*\*Allow meat to rest three minutes before carving or consuming.

## Gas Requirements

### LP Gas

If your grill is for LP Gas, the regulator supplied is set for an 11-in. water column (WC) and is for use with LP gas only. The factory-supplied regulator and hose must be used with a 20-lb. LP gas tank.

### Excess Flow Control and Low Heat

The propane regulator assembly incorporates an excess flow device designed to supply the grill with sufficient gas flow under normal conditions yet control excess gas flow. Rapid changes in pressure can trigger the excess flow device providing a low flame and low temperature. If the tank valve is turned open to allow gas flow while a burner valve is open, the surge of pressure will cause the device to activate. The device will remain closed until the pressure is equalized. This should occur within 5 seconds.

To ensure this does not cause difficulty in lighting the grill, follow these instructions:

1. Make sure all burner valves are "OFF".
2. Open the tank valve and wait 5 seconds.
3. Light the burners one at a time following the lighting instructions.

### Helpful Care and Maintenance Hints

Before grilling, pre-heat grill for 15 minutes on "HI" with hood down. To avoid uncontrolled flare-ups or grease fires, grill meats with hood open. Close hood if meats are thick or weather is cold, or if you are using a rotisserie or indirect cooking.

Always protect your hand with a pot holder or cooking glove when coming into contact with a hot surface.

Hood up when grilling meats, especially chicken. Hood down when indirect or rotisserie cooking.

NEVER leave your grill unattended while cooking.

After use, close hood, turn burners to HI for 15 min. for self-cleaning, grease burn off.

Care and Maintenance Time Table Chart

Grill Item	Frequency Based on Normal Use	Cleaning Method
Painted surface	Twice yearly	Car wax
Stainless surface	Twice yearly	Stainless cleaner
All grates	After each use	Burn off and wipe
Stainless grates	15 days	Wire brush/ Dishwasher safe
Porcelain grates	15 days	Scrub pad soapy water/Dishwasher safe
Burner heat tents	30 days	Wire brush
Burners	90 days	Wire brush
Burner box interior	120 days	Interior grill cleaning products (available at Sears)



## WARNING



**CALIFORNIA PROPOSITION 65**

1. Combustion by-products produced when using this product contain chemicals known to State of California to cause cancer, birth defects and other reproductive harm.
2. This product contains chemicals, including lead and lead compounds, known to State of California to cause cancer, birth defects or other reproductive harm.

**Wash your hands after using this product.**

# Natural Gas Conversion Kit

Your grill can be converted to natural gas. The conversion must be performed by a qualified gas technician.

Natural gas conversion kit  
 Kenmore Model # 20152  
 (Manufacturer Part No.: 9143028)

To purchase a Natural Gas Conversion kit call Sears at  
 1-800-4-MY-HOME®

### Natural Gas Connection Preparation:

1. Turn off gas supply, and then remove cap on gas supply side.
2. Recommended: Install a shut-off valve on gas supply side before installing the socket.
3. Socket should be installed by an authorized technician in accordance with the national fuel gas code (NFPA 54/ANSI223.1).
4. Before inserting plug, turn on gas supply and leak test all connections including the stem of the shut-off valve and the opening of the socket. For best results, use an ammonia-free soap & water solution.

### Operating Instructions:

1. To connect, push back socket sleeve.

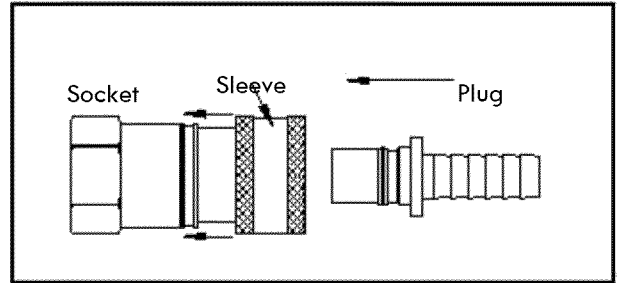

2. Insert plug and release sleeve.

3. Push plug until sleeve snaps forward. (Gas will flow automatically. Failure to connect plug properly to socket will inhibit gas flow to the appliance.)

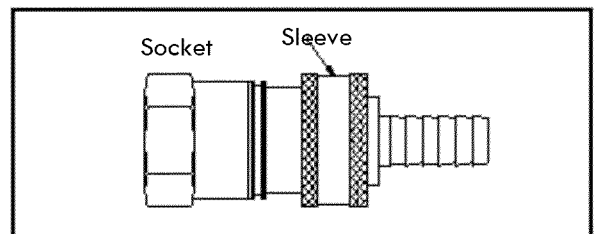

### To disconnect









1. Pull Sleeve back. Pull plug out of socket. (Gas is automatically shut off.)
2. Close shut-off valve or turn off gas supply, and replace dust caps on socket and plug.

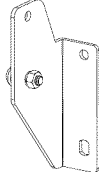

### Natural Gas

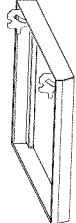
Now that your grill is converted to Natural Gas use, it is set for 7-inch water column (WC) pressure, and cannot be used with Propane Gas. Gas pressure is affected by gas line size and the length of gas line run from the house. Follow the recommendations in the chart below.

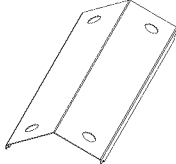
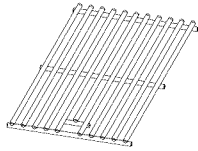

From House to Grill	
Distance	Tubing Size
Up to 25 ft.	3/8 in. diameter
26-50 ft.	1/2 in. diameter
51-100 ft.	2/3 of the run: 3/4 in. diameter 1/3 of the run :1/2 in. diameter
Over 101 ft.	3/4 in. diameter

**Part list detail with graphic:**

No.	QTY	Description	Artwork
1	1	Side Burner Drip Tray	
2	2	Side Table Left Bracket Assembly	
3	2	Side Table Right Bracket Assembly	
4	1	Left Side Shelf Panel Assembly	
5	1	Right Side Shelf Panel Assembly	
6	7	Knob	
7	5	Heat Diffusers	
8	4	Main burner Cooking Grid	
9	1	Warming Rack	

10	1	Drip Cup	
11	1	Side Burner Cooking Grid	
12	1	Hardware Tool Kit	

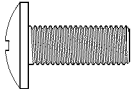
**Hardware Tool Kit:**

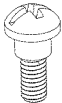
AA. AA Battery QTY: 1 pcs	BB. M6*12 Screw QTY: 8 pcs	CC. M6 Nut QTY: 4 pcs	DD. M6 Stretch Washer QTY: 4 pcs	EE. M6 Shoulder Screw QTY: 4 pcs
				

If you are missing hardware or have damaged parts after unpacking grill, call 1-800-482-0131 for replacement. To order replacement parts after using grill, call 1-800-4-MY-HOME®

NOTE: Some grill parts shown in the assembly steps may differ slightly in appearance from those on your particular grill model. However, the method of assembly remains the same

**Parts List:**

<b>No.</b>	<b>Description</b>	<b>Part. No.</b>	<b>QTY</b>	<b>No.</b>	<b>Description</b>	<b>Part. No.</b>	<b>QTY</b>
1	Warming Rack	2408460	1	44	Knob	2404108	7
2	Main Burner Assembly	CH255001	5	45	Switch	2404129	1
3	Hood Assembly	CH255002	1	46	Rotisserie Burner Ignition Wire	2408461	1
3.1	Hood Body	CH255003	1	47	Side Burner Ignition Wire	2408466	1
3.2	Hood Handle	2404015	1	48	450mm Main Burner Ignition Wire 450mm	2408464	3
3.3	Bezel-Handle	5201177	2	49	Main Burner Ignition Wire 550mm	2408477	1
3.4	Hood Pin	2307067	2	50	Main Burner Ignition Wire 750mm	2408465	1
3.5	Thermometer	2405329	1	51	Cart Rear Panel Assembly	5205582	1
4	Main Burner Cooking Grid	2408467	4	52	Side Cabinet Rear Panel Assembly	5205589	1
5	Heat Diffusers	5205557	5	53	Cart Top Beam	5205583	1
6	Drip Tray Assembly	CH255004	1	54	Cart Left Panel Assembly	5205586	1
7	Firebox Assembly	CH255005	1	55	Cart Mid Beam	5205710	1
8	Rear Cover	5015191	1	56	Drip Cup	5205585	1
9	Thermal Couple	2307766	1	57	Door Hinge	2307764	2
10	Nozzle Assembly	5205894	1	58	Castor	2100471	1
11	Rotisserie Burner Nozzle Bracket	5015253	1	59	Castor with Lock	2408469	1
12	Thermocouple Sitting Box	5015263	1	60	Firebox Insulated Panel with Drip Cup Bracket and Drip Tray Bracket	CH255007	1
13	Rotisserie Burner Electrode	2310928	1	61	Fascia Insulated Panel	5205561	1
14	Wire Stator	5015242	4	62	Side Burner Drip Tray Guide Rail	5015033	2
15	Infrared Rotisserie Burner	2307767	1	63	Side Burner Drip Tray	5204067	1
16	Rotisserie Burner Front Shield	5015190	1	64	Cart Inner Right Panel	5015040	1
17	Rotisserie Burner Ripple Tube	2307750	1	65	Cart Inner Left Panel	5205792	1
18	Length of Light Assembly 650mm	2307667	1	66	Firebox Right Bracket Assembly	5205590	1
19	Length of Light Assembly 100mm	2307666	1	67	Side Shelf Leaking Panel Assembly	5205591	1
20	Wire 750mm	2307752	1	68	Side Shelf Fixed Strip	5205576	1
21	Wire 1300mm	2307670	1	69	Fascia Heat Shield	5205565	1
22	Wire 600mm	2307751	1	70	Side Burner Injector Fixed Panel Assembly	5205575	1
23	Side Burner Pin	2300819	2	71	Cart Inner Right Panel Assembly	5205588	1
24	Side Burner Lid	5205573	1	72	Side Shelf Heat Shield	5205566	1
25	Side Burner Cooking Grid	2408468	1	73	Handle Insert	2404927	4
26	Side Burner and Soup Tray Assembly	CH255006	1	74	Refrigerator Rear Holder	5015052	2
27	Side Burner Electrode	2404273	1	75	Door Stop	2404076	1
28	Side Burner Support Cup	5205572	1	76	Base Assembly	5205581	1
29	Right Side Shelf Panel Assembly	5205578	1	77	Refrigerator	CH255008	1
30	Side Burner Table Panel	5205571	1	77.1	Main Body of Refrigerator	CH255009	1
31	Transformer Assembly	2203030	1	77.2	Refrigerator Storage Shelf	CH255010	1
32	Igniter	2307682	1	77.3	Refrigerator Door	CH255011	1

					Assembly		
<b>33</b>	Battery	2307756	1	<b>77.4</b>	Refrigerator Handle Assembly	CH255012	1
<b>34</b>	Side Shelf Left Bracket	5205579	2	<b>78</b>	Handle Bezel	5201175	8
<b>35</b>	Left Side Shelf Panel Assembly	5205577	1	<b>79</b>	Door Screw Cap	2100481	6
<b>36</b>	Side Shelf Right Bracket	5205580	2	<b>80</b>	Drawer Handle Assembly	5201886	3
<b>37</b>	Side Burner Ripple Tube	2307241	1	<b>81</b>	Drawer Assembly		2
<b>38</b>	Side Burner Nozzle Assembly	5205893	1	<b>82</b>	Guide Rail	2300864	4
<b>39</b>	Main Gas Tube & Valve Assembly	5205700	1	<b>83</b>	Match Holder Assembly	2408470	1
<b>40</b>	Micro Switch Wire	2203029	2	<b>84</b>	Rubber Loop	2100292	2
<b>41</b>	Regulator Assembly	5111941	1	<b>85</b>	Door Assembly	CH255013	1
<b>42</b>	Control Panel Assembly	5205562	1				
<b>43</b>	Bezel Knob	5109046	7				

<b>Other Parts :</b>
<b>Hardware Tool Kit 9143028</b>
<b>Use &amp; Care Guide 3108226</b>
<b>Not included with grill, sold separately: Natural Gas Conversion Kit, Part No. 20152</b>



Part Diagram:

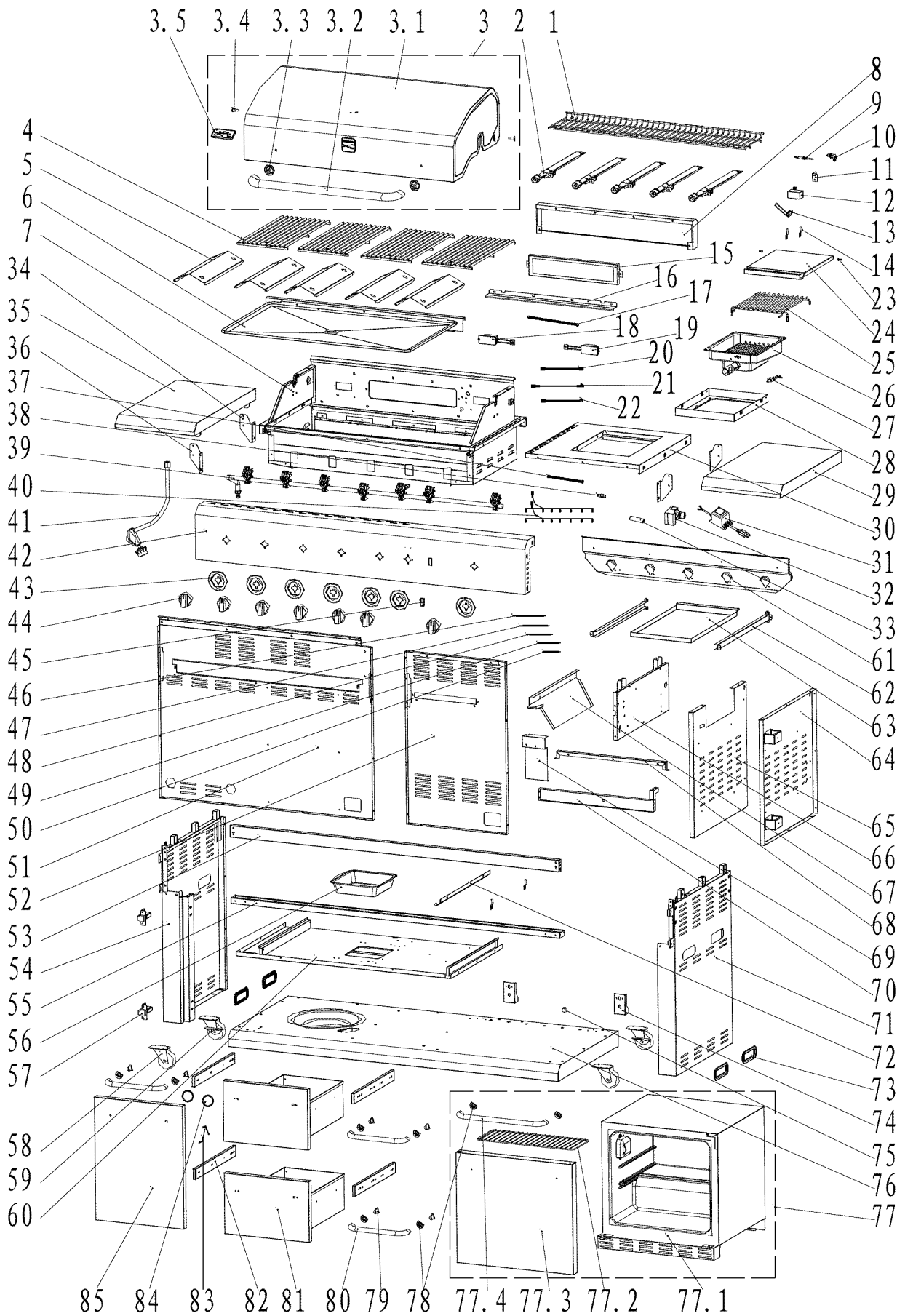

## ASSEMBLY INSTRUCTIONS

**IMPORTANT:** Assemble the grill on a flat level surface. During assembly, check the parts and hardware for correct identification against the list and diagrams on pages 13–14 of this Use & Care Guide.

### 1. Side Burner Drip Tray

Insert side burner drip tray into position at rear of side burner as shown.

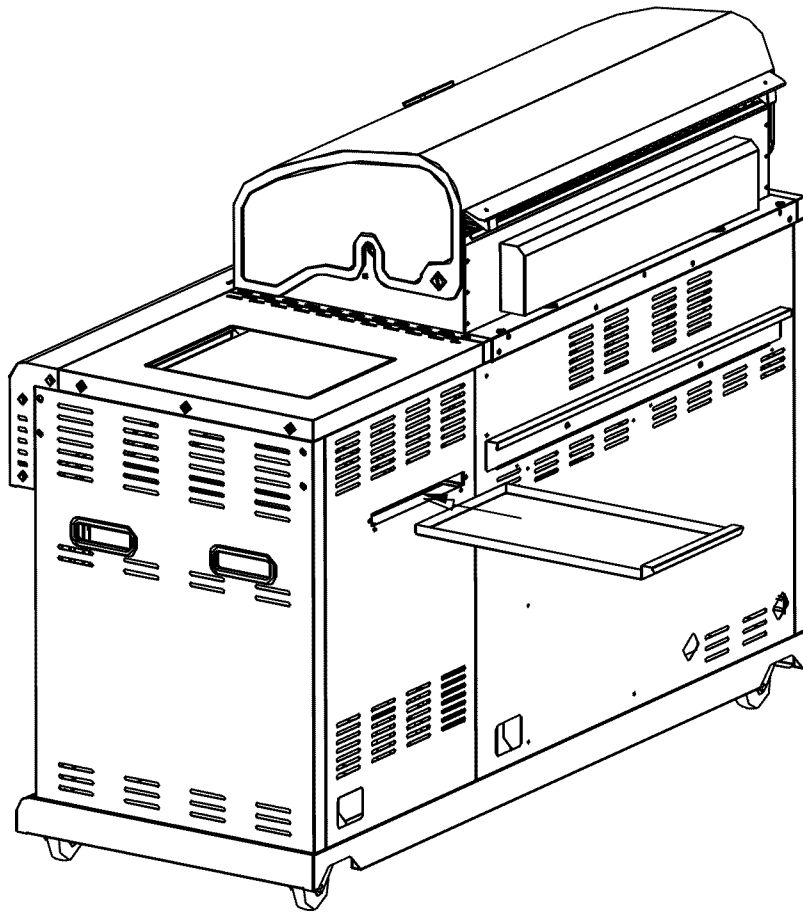

## 2.Side shelf brackets

Install the 4 side shelf brackets with 2 (BB)M6x12 screws each as shown.

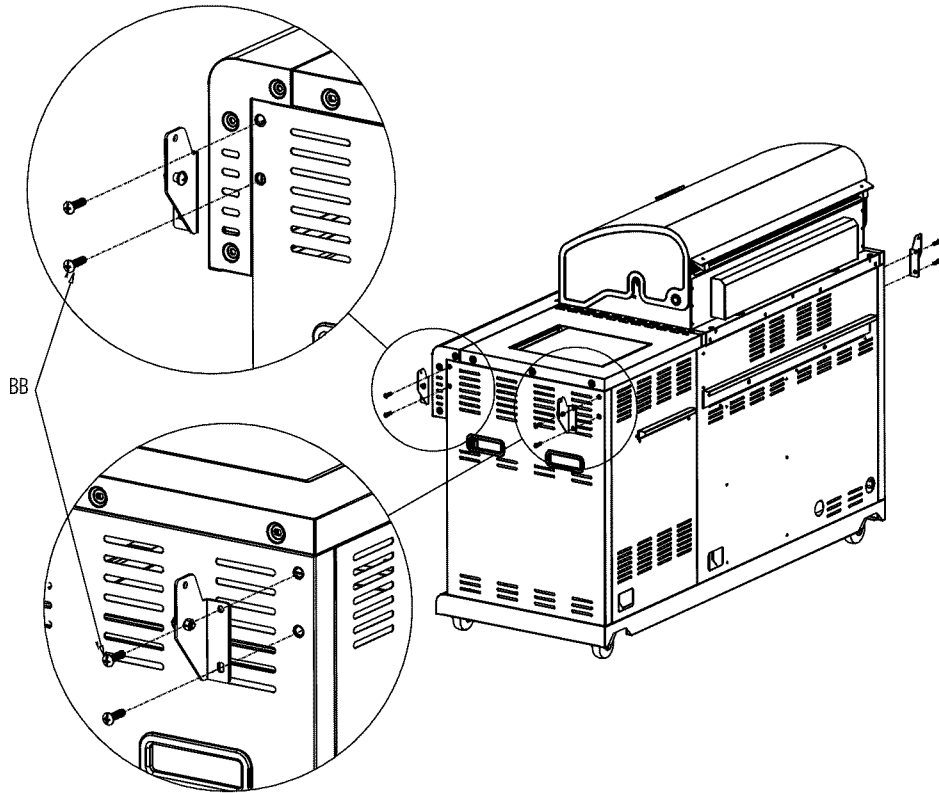

## 3.Side shelf attachment

Attach right side shelf onto brackets as shown with 2 (CC) M6 nuts, 2 (DD) M6 Stretch Washers and 2 (EE) M6 screws. Repeat for left side shelf.

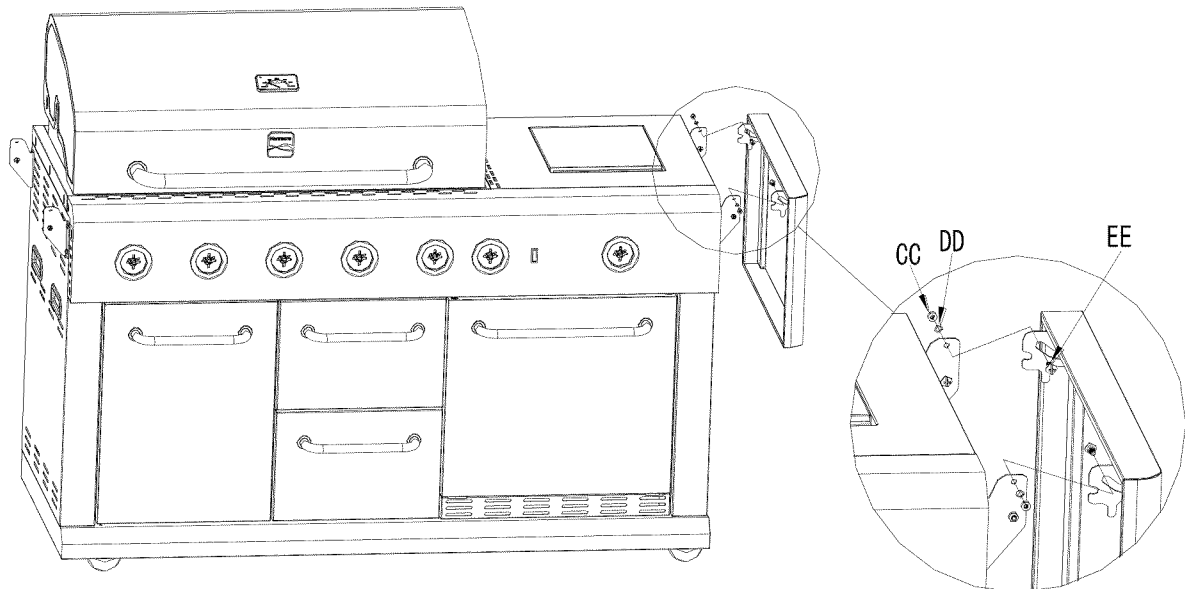

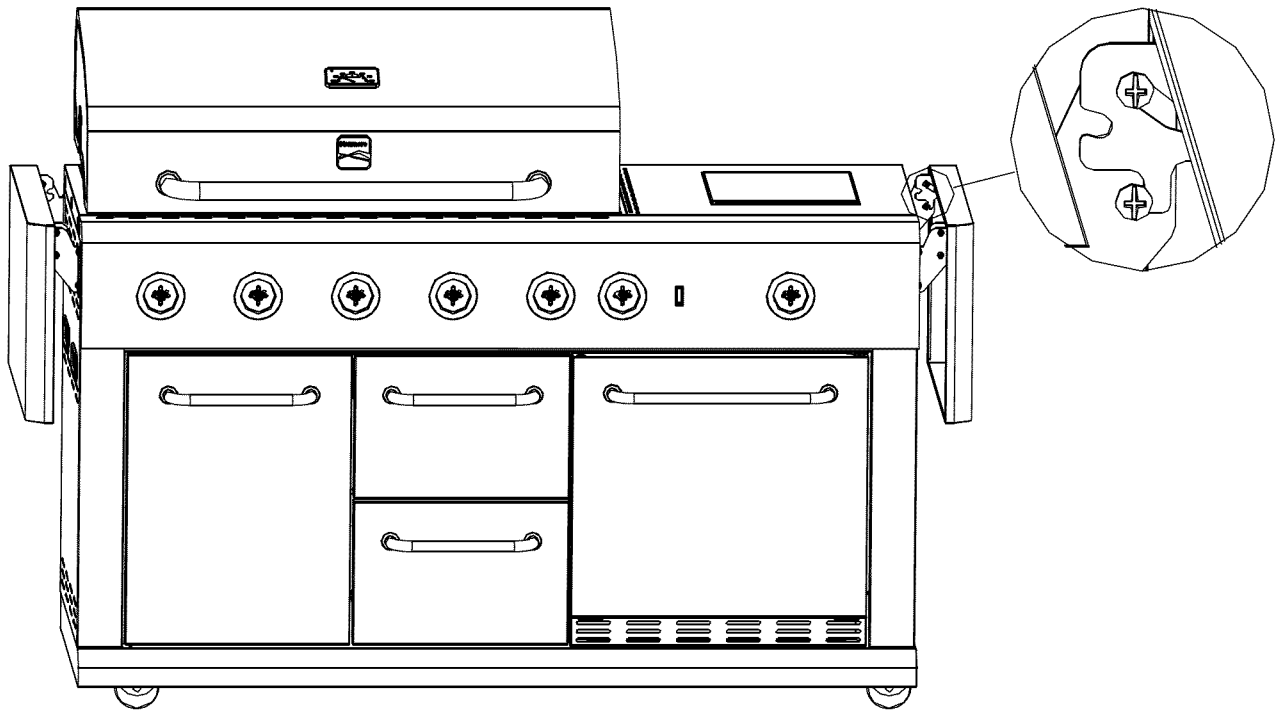

4. Control knobs, heat diffusers, cooking grids, warming rack

As shown below, attach the 7 control knobs and insert the 5 heat diffusers, 4 cooking grids and the warming rack.

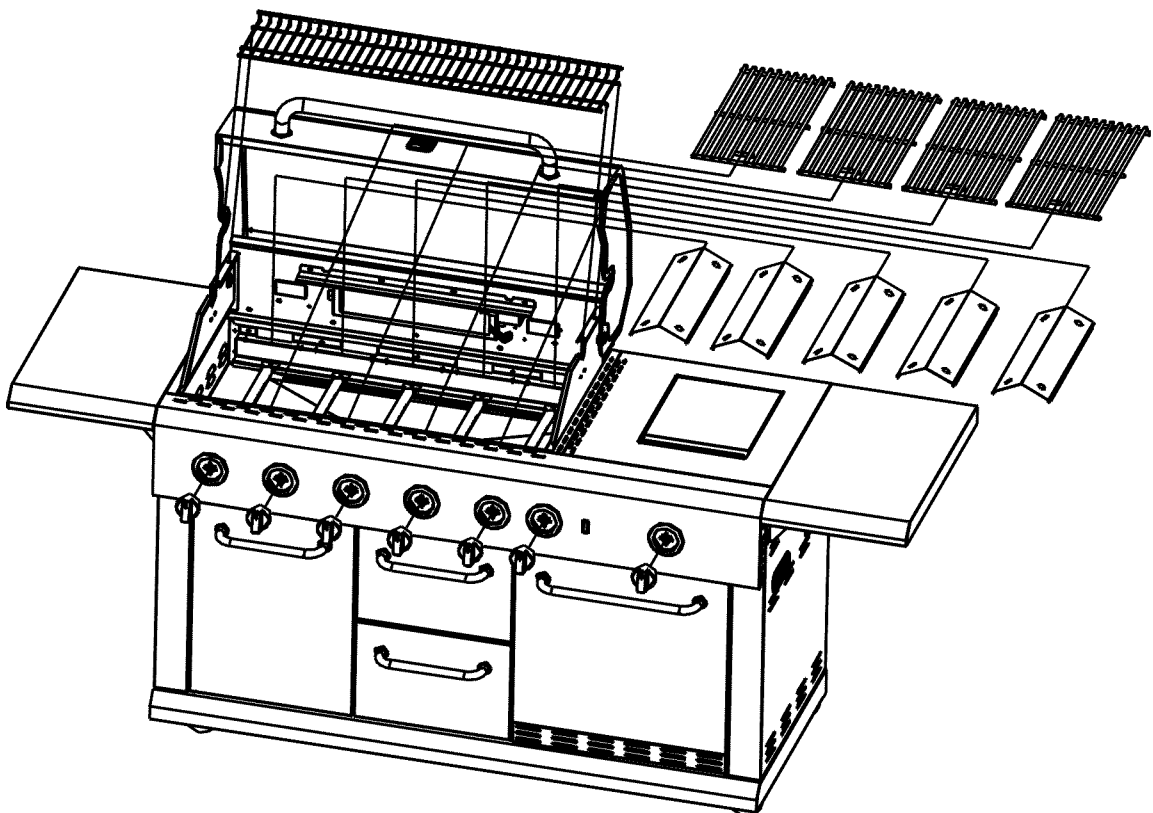

5. Insert the side burner cooking grid as shown.

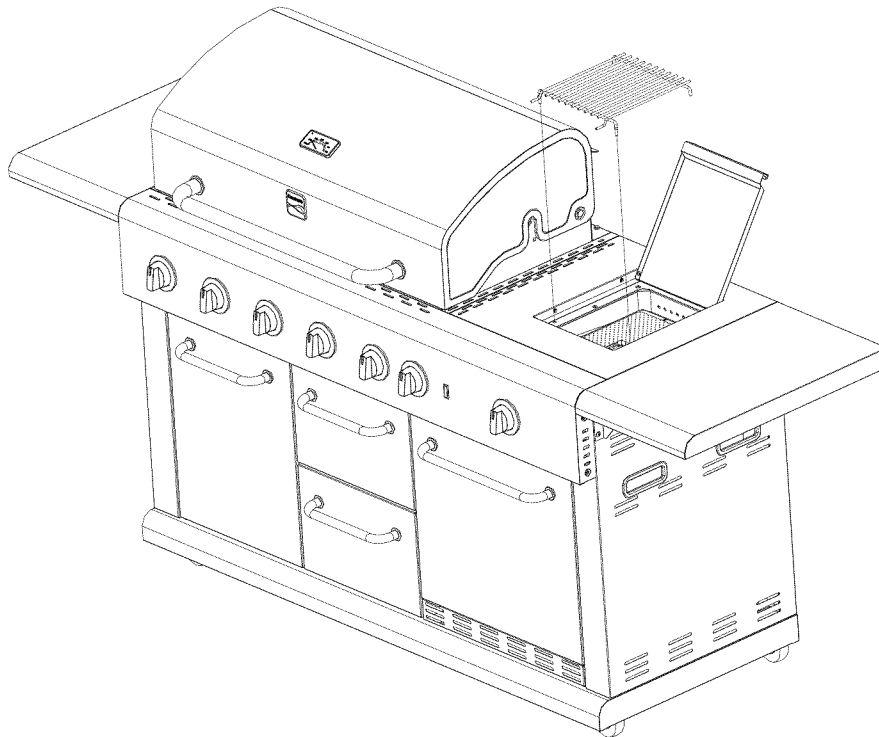

6. Open the left door and remove the battery compartment cap. Insert an AA battery into the compartment and reassemble the cap.

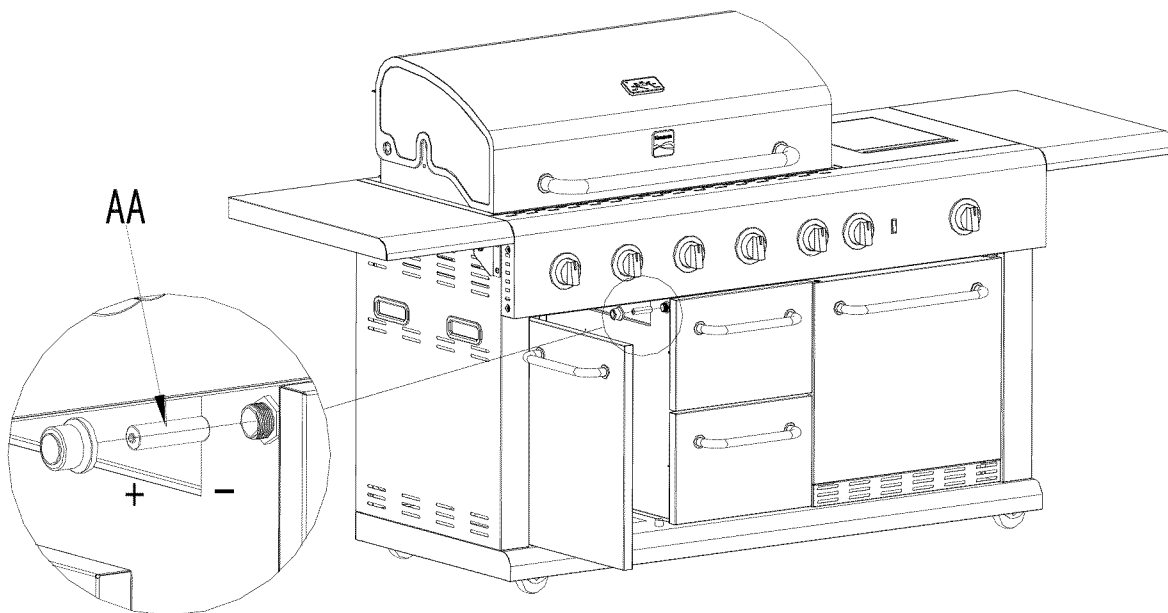

### 7. Drip cup

Open the left door and insert the drip cup into its bracket as shown.

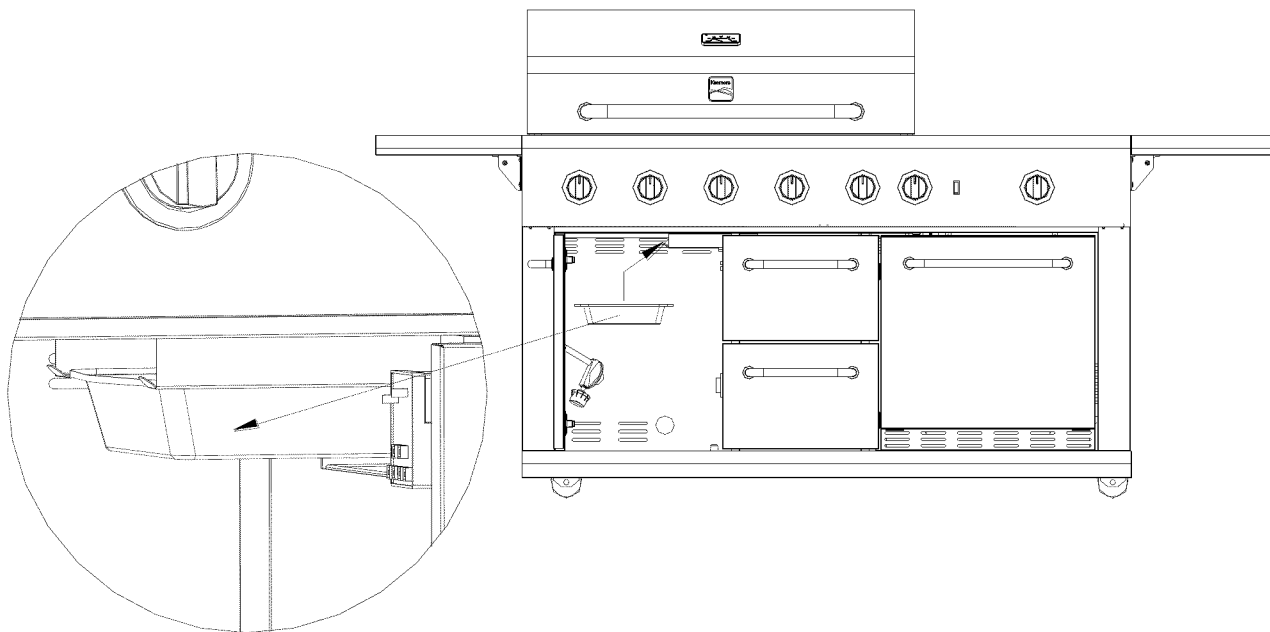

### 8. LP gas tank

- Loosen the tank retention screw.
- Place the LP gas tank, collar opening facing forward, into the tank location hole in the grill base.
- Connect the regulator to the LP tank valve.
- Tighten the tank retention screw to secure the tank in position.

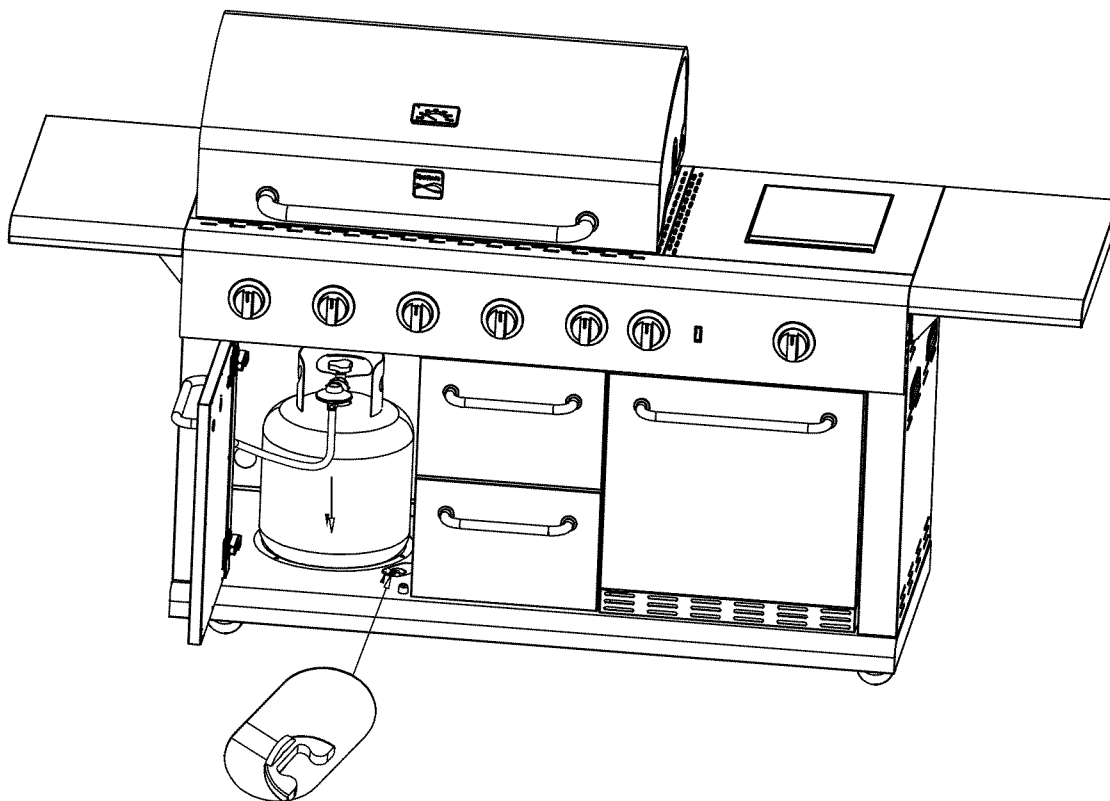

# TROUBLESHOOTING FOR GRILL

Problem	Possible Cause	Corrective Action
Grill or side burner will not light	<ol style="list-style-type: none"> <li>1. The ignition wire came off the electrical igniter.</li> <li>2. The distance between the ignition pin and the burner is greater than 0.1-0.2 inch(side burner).</li> <li>3. The ignition wire is broken.</li> <li>4. The battery has died.</li> <li>5. The battery is in the wrong polarity.</li> <li>6. The electrode tip does not produce sparks at the burner port.</li> <li>7. No gas supplied.</li> <li>8. Air shutter opening is too big.</li> </ol>	<ol style="list-style-type: none"> <li>1. Reconnect the ignition wire to the electrical igniter.</li> <li>2. Loosen the ignition pin and adjust the distance, then fasten it again.</li> <li>3. Call customer service for a replacement ignition wire.</li> <li>4. Install a new AA battery.</li> <li>5. Change the battery polarity.</li> <li>6. Reinstall the electrode.</li> <li>7. Turn on the regulator valve.</li> <li>8. Loosen the air shutter and adjust the opening to a smaller size.</li> </ol>
Burner flame is yellow and gas odor can be smelled	<ol style="list-style-type: none"> <li>1. The air shutter opening is not properly set.</li> <li>2. Spiders or insects block the air shutter.</li> <li>3. Gas leaks</li> </ol>	<ol style="list-style-type: none"> <li>1. Loosen the air shutter and adjust the opening to have blue flames. 1/4 in. opening for LPG. 1/8 in. or less opening for NG.</li> <li>2. Clean blockages.</li> <li>3. Check for the source of gas leaks.</li> </ol>
Excessive flare-up	<ol style="list-style-type: none"> <li>1. Grilling fatty meats while knobs on "HIGH".</li> <li>2. Spray water on gas flames.</li> <li>3. Hood closed when grilling.</li> </ol>	<ol style="list-style-type: none"> <li>1. Grill fatty meats when the grids are cold while the knobs are on the "LOW" setting. Move the meats to the warming rack if flare up continues until flame settles down.</li> <li>2. Never spray water on gas flames.</li> <li>3. Hood up when grilling.</li> </ol>

Problem	Possible Cause	Corrective Action
Burner blows out	<ol style="list-style-type: none"> <li>1. LP tank is empty.</li> <li>2. Burner is not aligned with the control valve.</li> <li>3. Gas supply is not sufficient.</li> </ol>	<ol style="list-style-type: none"> <li>1. Refill the LP Tank.</li> <li>2. Install the burner correctly.</li> <li>3. Check the gas supply hose and make sure there are no leaks and no knots.</li> </ol>
Low heat with the knob in "HI" position	<ol style="list-style-type: none"> <li>1. Low heat is found in natural gas models.</li> <li>2. Ports are blocked.</li> <li>3. LP tank has run out.</li> </ol>	<ol style="list-style-type: none"> <li>1. This model is set for 7 in. natural gas usage. Please check your natural gas supply system to have correct gas pressure. Regulator is not needed for NG model. Check the orifice if you installed NG nozzles.</li> <li>2. Clear ports of any obstructions.</li> <li>3. Refill the LP tank.</li> </ol>
Low heat, natural gas	Gas pressure is significantly affected by gas line and length of gas line from house gas line.	Check your gas line and make corrections by following the chart below. From House to Grill Distance Tubing Size Up to 25 ft. 3/8 in. diameter 26 -50 ft. 1/2 in. diameter 51 -100 ft. 2/3 in. of run 3/4 in. 1/3 in. of run 1/2 in.



Problem	Possible Cause	Corrective Action
Low heat, LP gas	The propane regulator assembly incorporates an excess flow device designed to supply the grill with sufficient gas flow. Rapid changes in pressure can trigger the excess flow device, providing a low flame and low temperature.	Please follow these instructions: 1. Make sure all burners are "OFF". 2. Open the tank valve and wait 5 minutes. 3. Light the burner one at a time following the lighting instructions listed on the door liner
Sudden drop in gas flow or low flame	<ol style="list-style-type: none"> <li>1. Out of gas.</li> <li>2. Excess flow valve tripped.</li> <li>3. Vapor lock at coupling nut/LP cylinder connection.</li> </ol>	<ol style="list-style-type: none"> <li>1. Check for gas in LP cylinder.</li> <li>2. Turn off knobs, wait 30 seconds and light grill. If flames are still low, turn off knobs and LP cylinder valve. Disconnect regulator. Reconnect regulator and leak test. Turn on LP cylinder valve, wait 30 seconds and then light grill.</li> <li>3. Turn off knobs and LP cylinder valve. Disconnect coupling nut from cylinder. Reconnect and retry.</li> </ol>
Cooking light will not turn on.	<ol style="list-style-type: none"> <li>1. No power supply.</li> <li>2. Defective halogen bulb.</li> <li>3. Internal wiring issue.</li> </ol>	<ol style="list-style-type: none"> <li>1. Check power supply and make sure transformer is properly plugged in.</li> <li>2. Replace the bulb.</li> <li>3. Check the wiring connections under the fire box. All wire connections must be tight. If any wires are damaged they should be replaced.</li> </ol>

## REFRIGERATOR SAFETY INFORMATION

---



To reduce the electrical shock or injury when using the refrigerator, follow basic precautions including the following:

### **WARNING**

- Plug into a grounded 3-prong GFI outlet. Do not remove grounding prong, do not use an adaptor. Because of potential safety hazards under certain conditions, it is strongly recommended that you do not use an extension cord with this appliance. However, if you must use an extension cord it is absolutely necessary that it be a UL/CUL-Listed, 3-wire grounding type appliance extension cord having a grounding type plug and outlet and that the electrical rating of the cord be 115 volts and at least 15 amperes.
- It is recommended the refrigerator be plugged into its own circuit. Use receptacles that cannot be turned off by a switch or pull chain.
- Never clean refrigerator parts with flammable fluids. These fumes can create a fire hazard or explosion. Do not store or use gasoline or other flammable vapors and liquids in the vicinity of this or any other appliance. The fumes can create a fire hazard or explosion.
- Before proceeding with cleaning and maintenance operations, make sure the power cord of the unit is disconnected.
- Do not connect or disconnect the electric plug when your hands are wet.
- Unplug the refrigerator or disconnect power before cleaning or servicing. Failure to do so can result in electrical shock or death.
- Do not attempt to repair or replace any part of your refrigerator unless it is specifically recommended in this manual. All other servicing should be referred to a qualified technician.

### **WARNING**

- To ensure proper ventilation for your refrigerator, the front of the unit must be completely unobstructed. Install the grill in a well-ventilated area where the temperature is between 55°F (13°C) and 110°F (43°C). If the temperature around the appliance is too low or high, cooling ability may be adversely affected. When grill is not in use it should be covered or moved to an area shielded from the outdoors to protect the refrigerator.
- The refrigerator should not be located directly next to other sources of high heat.
- The refrigerator must be installed with all electrical connections in accordance with state and local codes. A standard electrical supply (cfi, 115 V AC only, 60 Hz), properly grounded in accordance with the National Electrical Code and local codes and ordinances is required.
- Do not kink or pinch the power supply cord of refrigerator.
- The circuit breaker size should be 15 amperes.
- **It is important for the refrigerator to be level in order to work properly.** The grill must be located on a level surface to assure that the refrigerator is also level.
- Never allow children to operate, play with or crawl inside the refrigerator.
- Do not use solvent-based cleaning agents or abrasives on the interior. These cleaners may damage or discolor the interior.
- Do not use this apparatus for other than its intended purpose.



**Use only Ground Fault Circuit Interrupter (GFCI) protected circuit with this appliance.**

# INSTRUCTIONS

---

## Before Using Your Unit

- Your grill has a built-in refrigerator as shown in the illustration below. Clean the refrigerator interior surfaces with a soft cloth moistened in lukewarm water.

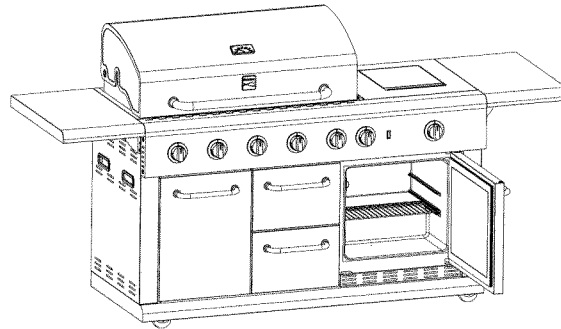

## Plugging for refrigerator

- Plug the unit into an exclusive, properly installed-grounded GFI wall outlet. Do not under any circumstances cut or remove the third (ground) prong from the power cord. Any questions concerning power and/or grounding should be directed toward a certified electrician.
- After plugging the appliance into a wall outlet, allow the unit to cool down for 2-3 hours before placing food into the refrigerator compartment.

## Setting the Temperature Control

- Your unit has only one control for regulating the temperature in the compartment. The temperature control is located on the left hand side of the refrigerator compartment.
- The range of the temperature control is from position "0" to "7." **"1" is warmer and "7" is cooler.** After 24 to 48 hours, adjust the temperature control to the setting that best suits your needs. The setting of "4" should be appropriate for normal use. **Do not keep the temperature control knob on the "7" position for a long period of time.**
- To turn the appliance off, turn the temperature control to "0."

## Electrical Connection



### CAUTION:

- Turning the temperature control to "0" position stops the cooling cycle but does not shut off the power of the unit.
- If the unit is unplugged, has lost power or is turned off, you must wait 3 to 5 minutes before restarting the unit. If you attempt to restart before this time delay, the unit will not start.

## Food Storage

- Wrap food in plastic wrap before storing. Place food evenly on wire rack.
- Let hot food cool down before putting into this refrigerator for saving energy.
- Don't open door frequently.
- Keep space between foods inside refrigerator.
- Keep food dry before storage.
- Remove food from refrigerator when power is out.
- Place your unit on a floor that is strong enough to support the unit when it is fully loaded.

## CARE AND MAINTENANCE

---

### Cleaning Your Unit

- Turn the temperature control to "0," unplug the unit, and remove the food and shelf. Clean the water with dry cloth when the frost turns into water.
- Wash the inside surfaces with a warm water and baking soda solution. The solution should be about 2 tablespoons of baking soda to one quart of water.
- Wash the shelf and tray with a mild detergent solution.
- The outside of the unit should be cleaned with mild detergent and warm water.
- Wring excess water out of the sponge or cloth before cleaning the area of the controls or any electrical parts.
- Wash the outside cabinet with warm water and mild liquid detergent. Rinse well and wipe dry with a clean soft cloth.

### CAUTION:

Do not use boiling water because it may damage the plastic parts. In addition, never use a sharp or metallic instrument to remove frost as it may damage the cooling system and will void the warranty. We recommend using a plastic scraper to remove any frost build-up.

### CAUTION:

Failure to unplug the unit could result in electrical shock or personal injury.

### Electrical Power Source Failures

Most power failures are corrected within a few hours and should not affect the temperature of your unit if you minimize the number of times the door is opened. If the power is going to be off for a longer period of time, you need to take the proper steps to protect your food. Remove all food to another suitable storage location such as an ice chest or other refrigerator.

### Vacation Time

- **Short vacation:** Leave the unit operating during vacations of less than three weeks.
- **Long vacation:** If the appliance will not be used for several months, remove all food and unplug the power cord. Clean and dry the interior thoroughly. To prevent odor and mold growth, leave the door open slightly, blocking it open if necessary.

### Energy Saving tips

- Let hot foods cool to room temperature before placing in the unit. Overloading the unit forces the compressor to run longer.
- Be sure to wrap foods properly and wipe containers dry before placing them in the unit. This cuts down on frost build up inside the unit.
- Unit wire rack should not be lined with aluminum foil, wax paper or paper towels. Liners interfere with cold air circulation, making the unit less efficient.
- Organize and label food to reduce door openings and extended searches. Remove as many items as needed at one time and close the door as soon as possible.

## TROUBLESHOOTING FOR REFRIGERATOR

Problem	Possible Cause	Corrective Action
Unit does not operate.	<ol style="list-style-type: none"> <li>1. Not plugged in.</li> <li>2. The circuit breaker tripped or a blown fuse.</li> <li>3. The unit temperature control is set at "OFF" position.</li> </ol>	<ol style="list-style-type: none"> <li>1. Firmly plug the cord into a live outlet with proper voltage.</li> <li>2. Reset the circuit breaker or replace the fuse.</li> <li>3. Refer to the Setting the Temperature Control section on page 4.</li> </ol>
Turn on and off frequently.	<ol style="list-style-type: none"> <li>1. The ambient temperature is hotter than normal.</li> <li>2. A large amount of food has been added to the unit.</li> <li>3. The door is opened too often.</li> <li>4. The door is not closed completely.</li> <li>5. The temperature control is not set correctly.</li> <li>6. The door gasket does not seal properly.</li> </ol>	<ol style="list-style-type: none"> <li>1. The motor will run longer under warm conditions. At normal room temperatures, expect your motor to run about 40% to 80% of the time. Under warmer conditions, expect it to run even more often.</li> <li>2 &amp; 3. Try to get everything you need out of the refrigerator at once, keep food organized so it is easy to find and close the door as the food is removed.</li> <li>4. Push the door firmly shut.</li> <li>5. Refer to the Setting the Temperature Control section on page 4.</li> <li>6. Clean gaskets and the surface that they touch. Rub a thin paraffin wax on the gaskets after cleaning.</li> </ol>
Vibrations.	The unit is not resting solidly on the floor.	Check to assure that the unit is level.
The unit seems to make too much noise.	Troublesome noises from the refrigerator: clicking, scraping, squealing, thumping, dripping or running water.	<ol style="list-style-type: none"> <li>1. The clicking noise usually indicates a compressor shutting down due to overload, overheating, shorting out, or the relay start up system.</li> <li>2. The scraping noise is usually the condenser fan rubbing against the cardboard shroud.</li> <li>3. The squealing is usually a defective condenser fan motor.</li> </ol>
The door will not close properly.	<ol style="list-style-type: none"> <li>1. The unit is not level.</li> <li>2. The gasket is dirty or bent.</li> <li>3. The food are out of position.</li> </ol>	<ol style="list-style-type: none"> <li>1. Check to assure that the unit is level.</li> <li>2. Clean gaskets and the surface that they touch. Rub a thin paraffin wax on the gaskets after cleaning.</li> <li>3. Check for anything blocking the door. Remove any food that may be preventing the door from closing.</li> </ol>

# TECHNICAL DATA AND WIRING DIAGRAM

## Technical Data:

Model	R-60
Rated Voltage (V)	AC110
Rated Frequency (Hz)	60
Rated Input Power (W)	110W
Energy Consumption (Kw.h /24h)	0.70
Rated Current (A)	1.45
Phase	1
Design Pressure (High) (Psig)	218
Design Pressure (Low) (Psig)	88
Refrigerant	R134a
Refrigerant Charge (Pounds)	0.07

## Wiring Diagram:

