

INSTALLATION INSTRUCTIONS

R-410A Split System Heat Pump

N4H3, C4H3, H4H3, T4H3,
N4H4, NXH5, CXH5, HXH5, TXH5

These instructions must be read and understood completely before attempting installation.

IMPORTANT: Effective January 1, 2015, all split system and packaged air conditioners must be installed pursuant to applicable regional efficiency standards issued by the Department of Energy.

Safety Labeling and Signal Words

DANGER, WARNING, CAUTION, and NOTE

The signal words **DANGER**, **WARNING**, **CAUTION**, and **NOTE** are used to identify levels of hazard seriousness. The signal word **DANGER** is only used on product labels to signify an immediate hazard. The signal words **WARNING**, **CAUTION**, and **NOTE** will be used on product labels and throughout this manual and other manuals that may apply to the product.

DANGER – Immediate hazards which **will** result in severe personal injury or death.

WARNING – Hazards or unsafe practices which **could** result in severe personal injury or death.

CAUTION – Hazards or unsafe practices which **may** result in minor personal injury or product or property damage.

NOTE – Used to highlight suggestions which **will** result in enhanced installation, reliability, or operation.

Signal Words in Manuals

The signal word **WARNING** is used throughout this manual in the following manner:

 **WARNING**

The signal word **CAUTION** is used throughout this manual in the following manner:

 **CAUTION**

Signal Words on Product Labeling

Signal words are used in combination with colors and/or pictures on product labels.

TABLE OF CONTENTS

Inspect New Unit	2
Safety Considerations	2
Location	2
Clearances	2
Unit Support	2
Refrigeration System	3
Electrical Wiring	7
Defrost System	9
Start-up Procedure	11
Refrigerant Charge	11
Sequence of Operation	12
Troubleshooting	16
Maintenance	16
Comfort Alert™ Diagnostics Codes	17
R-410A Quick Reference Guide	18

 **WARNING**

DEATH, PERSONAL INJURY, AND/OR PROPERTY DAMAGE HAZARD

Failure to carefully read and follow this warning could result in equipment malfunction, property damage, personal injury and/or death.

Installation or repairs made by unqualified persons could result in equipment malfunction, property damage, personal injury and/or death.

The information contained in this manual is intended for use by a qualified service technician familiar with safety procedures and equipped with the proper tools and test instruments.

Installation must conform with local building codes and with the National Electrical Code NFPA70 current edition or Canadian Electrical Code Part 1 CSA C.22.1.

INSPECT NEW UNIT

After uncrating unit, inspect thoroughly for hidden damage. If damage is found, notify the transportation company immediately and file a concealed damage claim.

SAFETY CONSIDERATIONS

Consult a qualified installer, service agency, or the dealer/distributor for information and assistance. The qualified installer must use factory authorized kits and accessories when modifying this product. Refer to the individual instructions packaged with the kit or accessory when installing.

The weight of the product requires careful and proper handling procedures when lifting or moving to avoid personal injury. Use care to avoid contact with sharp or pointed edges.

Follow all safety codes. Wear safety glasses, protective clothing, and work gloves. Use a heat sinking material – such as a wet rag – during brazing operations. Keep a fire extinguisher available. Consult local codes and the National Electric Code (NEC) for special requirements.

Improper installation, adjustment, alteration, service or maintenance can void the warranty.

Locate unit in a well drained area, or support unit high enough so that water runoff will not enter the unit.

Locate unit away from areas where heat, lint, or exhaust fumes will be discharged onto unit (as from dryer vents).

Locate unit away from recessed or confined areas where recirculation of discharge air may occur (refer to CLEARANCES section of this document).

Roof-top installation is acceptable providing the roof will support the unit and provisions are made for water drainage and noise/vibration dampening.

NOTE: Roof mounted units exposed to wind may require wind baffles. Consult the manufacturer for additional information.

CLEARANCES

When installing, allow sufficient space for airflow clearance, wiring, refrigerant piping, and service. Allow 24 in. (610 mm) clearance to service end of unit and 48 in. (1219.2 mm) above unit. For proper airflow, a 6 in. (152.4 mm) clearance on one side of unit and 12 in. (304.8 mm) on all remaining sides must be maintained. Maintain a distance of 24 in. (609.6 mm) between units or 18 in. (457.2 mm) if no overhang within 12 ft. (3.66m). Position so water, snow, or ice from roof or eaves cannot fall directly on unit.

On rooftop applications, locate unit at least 6 in. (152.4mm) above roof surface.

UNIT SUPPORT

NOTE: Unit must be level | 2 degrees {a inch rise or fall per foot of run (10mm rise or fall per 305 mm of run) } or compressor may not function properly.

A. GROUND LEVEL INSTALLATION

The unit must be level and supported above grade by beams, platform, or a pad. Platform or pad can be of open or solid construction but should be of permanent materials such as concrete, bricks, blocks, steel, or pressure-treated timbers approved for ground contact. Soil conditions must be considered so that the platform or pad does not shift or settle and leave the unit partially supported. Minimum pad dimensions are shown in Figure 1.

If beams or an open platform are used for support, it is recommended that the soil be treated or area be graveled to reduce the growth of grasses and weeds.

To minimize vibration or noise transmission, it is recommended that supports not be in contact with the building structure. However, slabs on grade constructions with an extended pad are normally acceptable.



WARNING

ELECTRICAL SHOCK HAZARD

Failure to turn off the main (remote) electrical disconnect device could result in personal injury or death.

Before installing, modifying or servicing system, turn OFF the main (remote) electrical disconnect device. There may be more than one disconnect device. Lock out and tag switch with a suitable warning label.



CAUTION

PROPERTY DAMAGE HAZARD

Failure to follow this caution may result in property damage

R-410A systems operate at higher pressures than R-22 systems. When working with R-410A systems, use only service equipment and replacement components specifically rated or approved for R-410A service.

LOCATION

Check local codes for regulations concerning zoning, noise, platforms, and other issues.

Locate unit away from fresh air intakes, vents, or bedroom windows. Noise may carry into the openings and disturb people inside.



CAUTION

PROPERTY DAMAGE HAZARD

Failure to follow this caution may result in property damage.

Top surface of platform must be above estimated snow-fall level to prevent snow blocking coil and to allow water melt to drain from unit.

Figure 1 Tie Down Knockouts

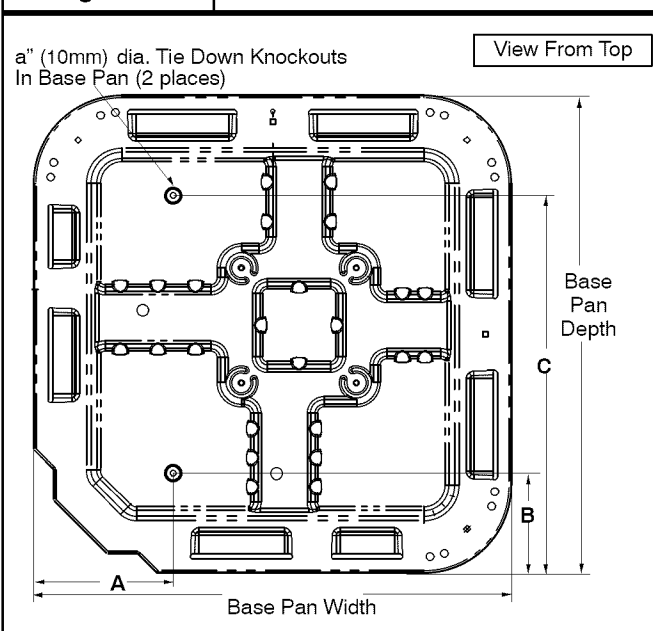

Inches (mm)

Base Pan Width x Depth	Tie Down Knockouts			Minimum Mounting Pad Dimensions
	A	B	C	
23 x 23 (584 x 584)	7-3/4 (197)	4-7/16 (113)	18 (457)	23 x 23 (584 x 584)
25-11/16 x 25-11/16 (652 x 652)	9-1/16 (230)	4-7/16 (113)	21-1/4 (540)	26 x 26 (660 x 660)
31-1/8 x 31-1/8 (791 x 791)	9-1/16 (230)	6-1/2 (165)	24-5/8 (625)	31-1/2 x 31-1/2 (800 x 800)
34-15/16 x 34-15/16 (887 x 887)	9-1/16 (230)	6-1/2 (165)	28-7/16 (722)	35 x 35 (889 x 889)

B. ROOF TOP INSTALLATION

This type of installation is not recommended on wood frame structures where low noise levels are required.

Supporting structure or platform for the unit must be level. If installation is on a flat roof, locate unit minimum 6 inches (152mm) above roof level.

Place the unit over one or more load bearing walls. If there are several units, mount them on platforms that are self-supporting and span several load bearing walls. These suggestions are to minimize noise and vibration transmission through the structure. If the structure is a home or apartment, avoid locating the unit over bedrooms or study.

NOTE: When unit is to be installed on a bonded guaranteed roof, a release must be obtained from the building owner to free the installer from all liabilities.

C. FASTENING UNIT DOWN

If conditions or local codes require the unit be attached in place, remove the knockouts in the base pan and install tie down bolts through the holes (refer to Figure 1).

Contact local distributor for hurricane hold-down details and the P.E. (Professional Engineer) certification, when required.



CAUTION

PROPERTY DAMAGE HAZARD

Failure to follow this caution may result in property damage.

Inadequate unit support may cause excessive vibration, noise, and/or stress on the refrigerant lines, leading to refrigerant line failure.

REFRIGERATION SYSTEM

A. COMPONENT MATCHES

Check to see that the proper system components are in place, especially the indoor coil.

R-410A outdoor units can only be used with R-410A specific indoor coils. If there is a refrigerant mis-match, consult the indoor coil manufacturer to determine if a refrigerant conversion kit is available for the indoor coil.

This outdoor unit is designed to achieve maximum efficiency when used with indoor coils that utilize a TXV refrigerant metering device or Piston with Teflon ring metering device. If any other type of metering device is installed on the indoor coil, consult the indoor coil manufacturer to determine if a conversion kit is available.

Installing with TXV.

When installing a TXV on an indoor coil, follow the instructions provided with the new TXV.

A typical TXV installation is shown in Figure 2.

Figure 2 Typical TXV Installation

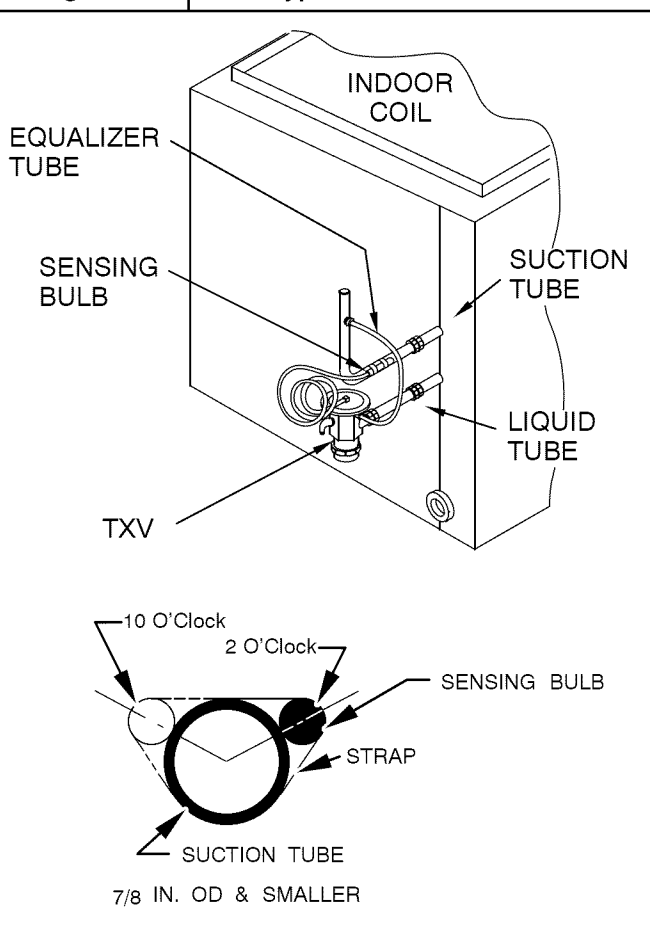

Installing with Indoor Piston – cooling operation.
(Heat pumps also use an outdoor piston for heating operation, refer to section F.)

Check piston size shipped with indoor unit to see if it matches required indoor piston size shown on outdoor unit rating plate.

If it does not match, replace indoor piston with *cooling* piston, according to size marked on outdoor unit rating plate. (Some outdoor models include a cooling piston in the accessory bag.)

Heating piston is shipped in the service valve – refer to section F.

Example fan coils with piston: FEM4P, FSM4P, FSU4P, FMA4P, FMC4P, FMU4P.

See Figure 3.

When changing indoor piston, use a back-up wrench. Finger tighten hex nut, then tighten with wrench 1/2 turn. Do not exceed 30 ft-lbs (40.7 N-m). The indoor piston contains a Teflon ring (or seal) which is used to seat against the inside of distributor body, and must be installed properly to ensure proper seating in the direction for cooling operation.

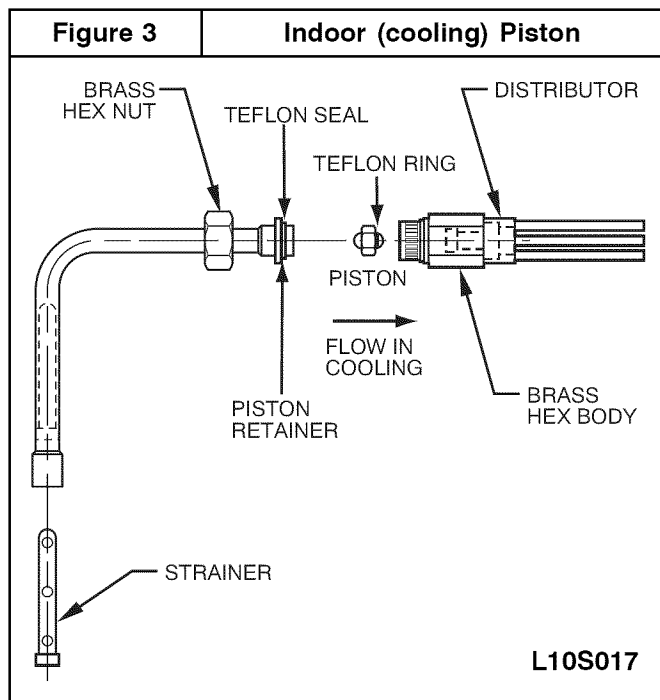

Refer to **Product Specifications and Long Line Applications Guideline** for line set sizing.

NOTE: Total line set length must not exceed 200 feet (61m).

NOTE: A crankcase heater must be used when the refrigerant line length exceeds 80 feet (24.4m).

If outdoor unit is more than 10 feet (3m) higher than the indoor coil, refer to the Long Line Applications Guideline for instructions.

NOTE: When the outdoor unit is higher than the indoor coil, the vertical separation must not exceed 100 feet (30m).

NOTE: When the outdoor unit is lower than the indoor coil, the vertical separation must not exceed 50 feet (15.2m).

If it is necessary to add refrigerant line in the field, use dehydrated or dry, sealed, deoxidized, copper refrigeration tubing. Do not use copper water pipe.

Do not remove rubber plugs or caps from copper tubing until connections are ready to be made.

Be extra careful when bending refrigeration tubing. Tubing can “kink” easily, and if this occurs, the entire length of tubing must be replaced.

⚠ WARNING

PERSONAL INJURY HAZARD

Failure to relieve system pressure could result in personal injury and/or death.

Relieve pressure and recover all refrigerant before servicing existing equipment, and before final unit disposal. Use all service ports and open all flow-control devices, including solenoid valves.

⚠ CAUTION

UNIT OPERATION HAZARD

Failure to follow this caution may result in improper product operation.

Do not leave system open to atmosphere any longer than absolutely required for installation. Internal system components – especially refrigerant oils – are extremely susceptible to moisture contamination. Keep ends of tubing sealed during installation until the last possible moment.

⚠ CAUTION

PRODUCT OPERATION HAZARD

Failure to follow this caution may result in improper product operation.

If using a TXV in conjunction with a single-phase reciprocating compressor, a compressor start capacitor and relay are required. Consult outdoor unit pre-sale literature for start assist kit part number.

B. REFRIGERANT LINE SETS

The refrigerant line set must be properly sized to assure maximum efficiency and proper oil circulation.

C. ROUTING AND SUSPENDING REFRIGERANT LINES

Run refrigerant lines as straight and direct as possible, avoiding unnecessary bends and turns. Always insulate the entire suction line. Both lines should be insulated when routed through an attic or when routed through an underground raceway.

When routing refrigerant lines through a foundation or wall, do not allow refrigerant lines to come in direct contact with the building structure. Make openings large enough so that lines can be wrapped with extra insulation. Fill all gaps with RTV caulk. This will prevent noise

transmission between the tubing and the foundation or wall.

Along floor or ceiling joists, suspend refrigerant lines so that they do not contact the building structure, water

pipes, or ductwork. Use insulated or suspension type hangers. Metal straps must be at least 1" (25mm) wide to avoid cutting into the tube insulation. Keep the liquid and suction lines separate. Refer to Figure 4.

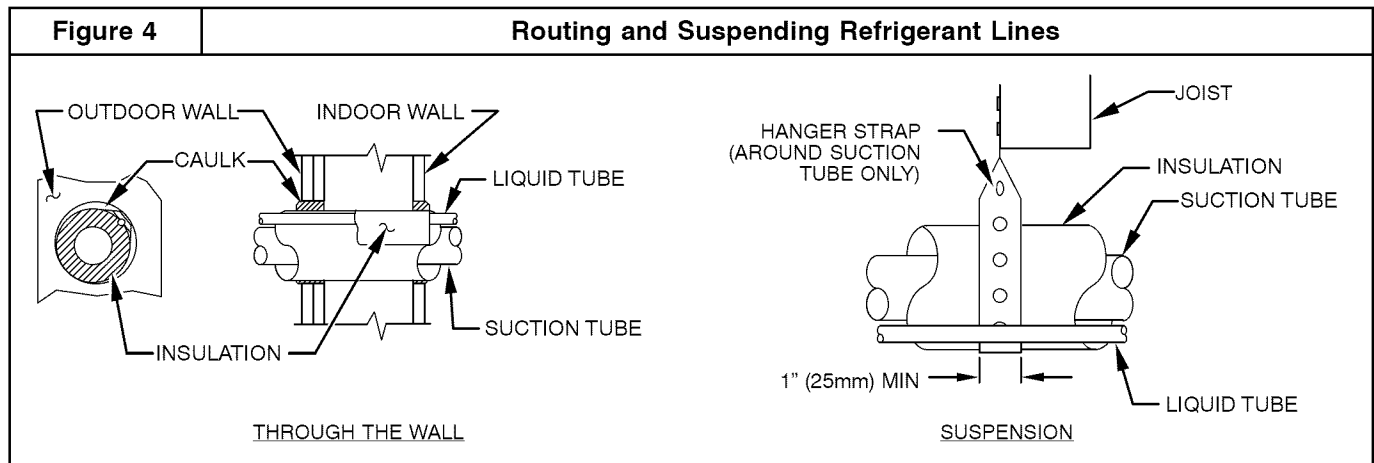

	CAUTION
<p>UNIT OPERATION HAZARD Failure to follow this caution may result in improper product operation. Do not bury more than 36" (1m) of line set underground. Refrigerant may migrate to cooler buried section during extended periods of unit shut-down, causing refrigerant slugging and possible compressor damage at start-up. If ANY section of the line set is buried underground, provide a minimum 6" (152mm) vertical rise at the service valve.</p>	

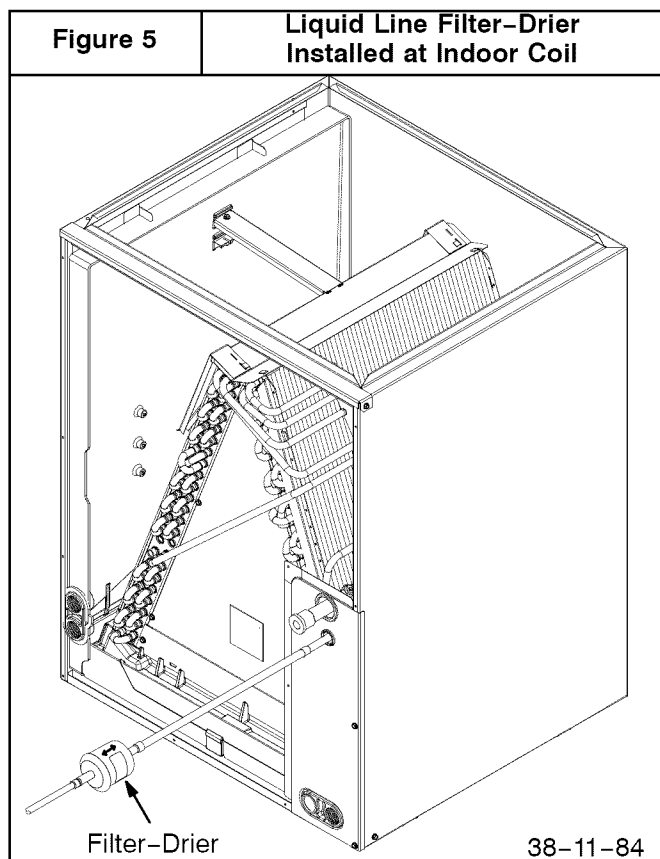

D. OUTDOOR UNIT HIGHER THAN INDOOR UNIT

Proper oil return to the compressor should be maintained with suction gas velocity. If velocities drop below 1500 fpm (feet per minute), oil return will be decreased. To maintain suction gas velocity, do not upsize vertical suction risers.

E. LIQUID LINE FILTER-DRIER

Outdoor units are shipped with an appropriate filter-drier for installation in the liquid line. Leave the plugs in the tube ends until the filter-drier is installed. The optimal location for the filter-drier is close to the indoor coil. Heat pump filter-driers are "bi-flow" type. Either end can be pointed towards indoor coil. Refer to Figure 5.

F. SERVICE VALVES

Service valves are closed and plugged from the factory. Outdoor units are shipped with a refrigerant charge sealed in the unit. Leave the service valves closed until all other refrigerant system work is complete or the charge will be lost. Leave the plugs in place until line set tubing is ready to be inserted.

Heat pumps require a piston metering device in the liquid service valve for proper heating operation. Piston is shipped in the piston body of the liquid service valve, temporarily held in place with a plastic cap. Do not remove the plastic cap until line set tubing is ready to be installed.

Refer to Figure 6 and follow these steps for piston installation:

1. Remove plastic cap holding piston in piston body of liquid service valve.
2. Check that piston size (stamped on side of piston) matches with number listed on unit rating plate. Return piston to piston body of liquid service valve (either direction).
3. Find plastic bag taped to unit containing copper adapter tube, brass nut, and plastic washer.
4. Install plastic washer in the seat inside piston body.
5. Fit brass nut onto adapter tube and install tube onto liquid service valve. Tighten nut finger tight, then wrench additional 1/2 turn only [15-ft lbs (20.3 N-m)]. Over tightening may damage the plastic washer.

Service valve bodies are brass and suction tube stub is copper.

Apply heat absorbing paste or heat sink product between service valve and joint. Wrap service valves with a heat sinking material such as a wet cloth.

Braze joints using a Sil-Fos or Phos-copper alloy.

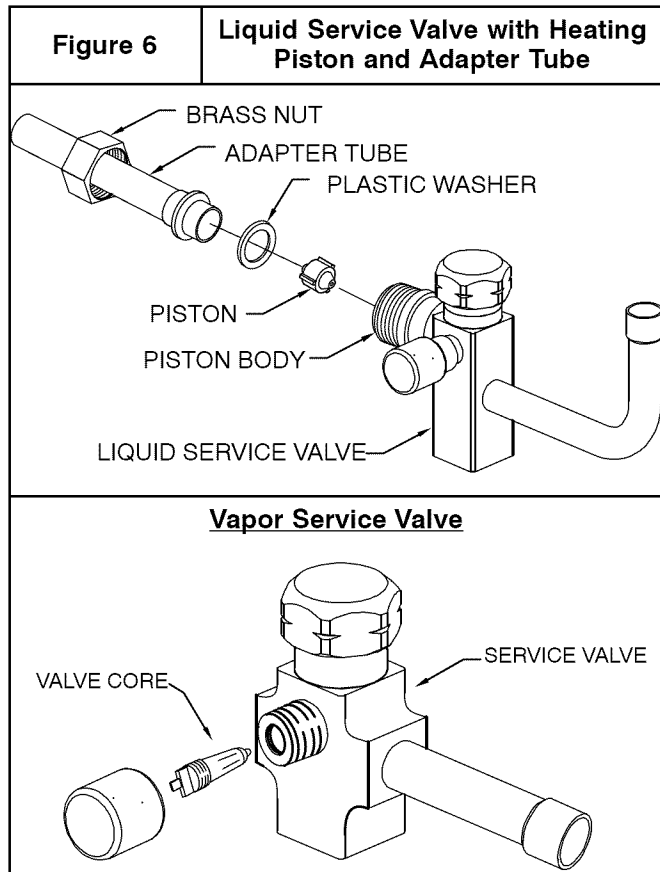

⚠ CAUTION

PRODUCT DAMAGE HAZARD

Failure to follow this caution may result in product damage.

Braze with Sil-Fos or Phos-copper alloy on copper-to-copper joints and wrap a wet cloth around rear of fitting to prevent damage to TXV.

H. EVACUATING LINE SET AND INDOOR COIL

The unit is shipped with a factory refrigerant charge. The liquid line and suction line service valves have been closed after final testing at the factory. Do not disturb these valves until the line set and indoor coil have been evacuated and leak checked, or the charge in the unit may be lost.

NOTE: Do not use any portion of the factory charge for purging or leak testing. The factory charge is for filling the system only after a complete evacuation and leak check has been performed.

⚠ CAUTION

PRODUCT DAMAGE HAZARD

Failure to follow this caution may result in product damage.

Never use the outdoor unit compressor as a vacuum pump. Doing so may damage the compressor.

G. BRAZING CONNECTIONS

NOTE:

For Liquid Service Valve – Braze lineset to adapter tube BEFORE bolting adapter to valve. This helps prevent overheating and damage to plastic washer or o-ring.

For Vapor Service Valve – remove valve core from schrader port on Service Valve BEFORE brazing. This helps prevent overheating and damage to valve seals (refer to Figure 6). Replace valve core when brazing is completed.

⚠ WARNING

FIRE HAZARD

Failure to remove refrigerant and oil charge before brazing could result in personal injury, death, and/or property damage.

Refrigerant and oil mixture could ignite and burn as it escapes and contacts brazing torch. Make sure the refrigerant charge is properly removed from both the high and low sides of the system before brazing any component or lines.

Clean line set tube ends with emery cloth or steel brush. Remove any grit or debris.

Insert line set tube ends into service valve tube stubs.

Line set and indoor coil should be evacuated using the recommended deep vacuum method of 500 microns. If deep vacuum equipment is not available, the alternate triple evacuation method may be used by following the specified procedure.

If vacuum must be interrupted during the evacuation procedure, always break vacuum with dry nitrogen.

Deep Vacuum Method

The deep vacuum method requires a vacuum pump capable of pulling a vacuum to 500 microns and a vacuum gauge capable of accurately measuring this vacuum level. The deep vacuum method is the most positive way of assuring a system is free of air and water.

Watch the vacuum gauge as the system is pulling down. The response of the gauge is an indicator of the condition of the system (refer to Figure 7).

With no leaks in the system, allow the vacuum pump to run for 30 minutes minimum at the deep vacuum level.

Triple Evacuation Method

The triple evacuation method should only be used when system does not contain any water in liquid form and vacuum pump is only capable of pulling down to 28 inches of mercury (711mm Hg). Refer to Figure 8 and proceed as follows:

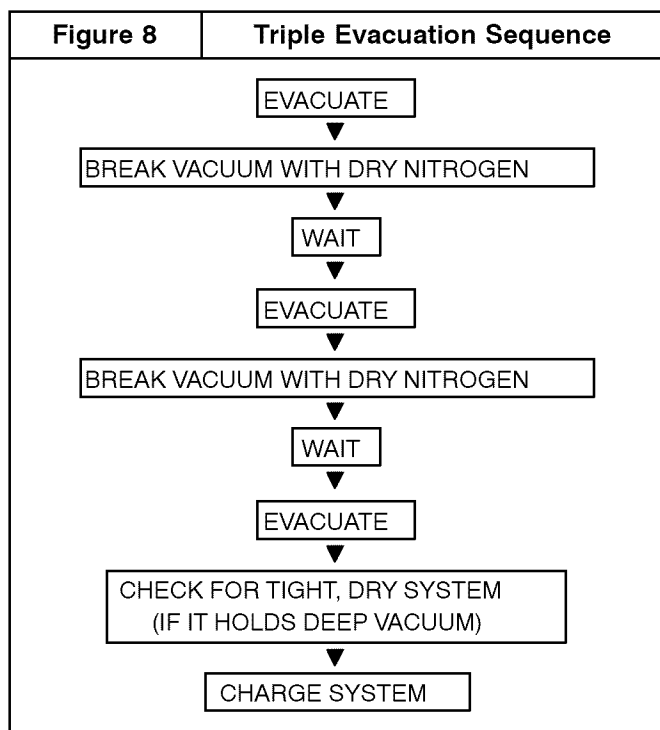
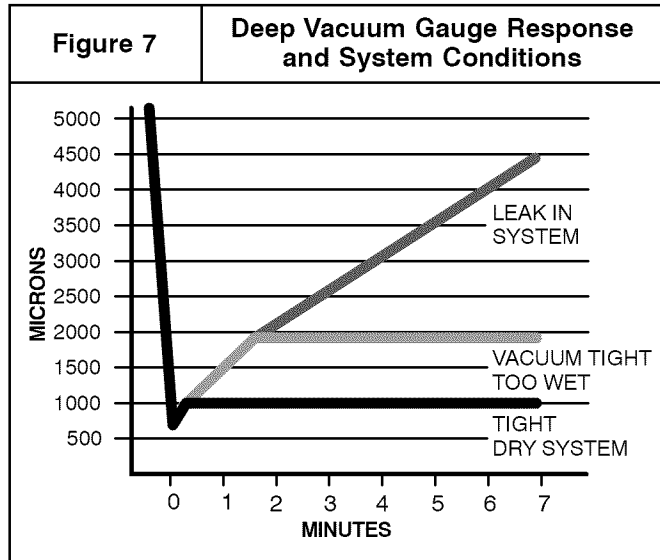

1. Pull system down to 28 inches of mercury (711mm Hg) and allow pump to continue operating for an additional 15 minutes.
2. Close manifold valves or valve at vacuum pump and shut off vacuum pump.
3. Connect a nitrogen cylinder and regulator to system and fill with nitrogen until system pressure is 2 psig.
4. Close nitrogen valve and allow system to stand for 1 hour. During this time, dry nitrogen will diffuse throughout the system absorbing moisture.

5. Repeat this procedure as indicated in Figure 8.
6. After the final evacuate sequence, confirm there are no leaks in the system. If a leak is found, repeat the entire process after repair is made.

I. OPENING SERVICE VALVES

Outdoor units are shipped with a refrigerant charge sealed in the unit. Opening the service valves releases this charge into the system.

NOTE: Open the Suction service valve first. If the Liquid service valve is opened first, oil from the compressor may be drawn into the indoor coil TXV, restricting refrigerant flow and affecting operation of the system.

Remove Suction service valve cap and insert a hex wrench into the valve stem. Hold the valve body steady with an end-wrench and back out the stem by turning the hex wrench counterclockwise. Turn the stem until it just contacts the rolled lip of the valve body.

After the refrigerant charge has bled into the system, open the Liquid service valve.

NOTE: These are not back-seating valves. It is not necessary to force the stem tightly against the rolled lip.

The service valve cap is a primary seal for the valve and must be properly tightened to prevent leaks. Make sure cap is clean and apply refrigerant oil to threads and sealing surface on inside of cap.

Tighten cap finger tight and then tighten additional 6 of a turn (1 wrench flat) to properly seat the sealing surfaces.

J. GAUGE PORTS

Check for leaks at the schrader ports and tighten valve cores if necessary. Install plastic caps finger tight.

ELECTRICAL WIRING

⚠ WARNING

ELECTRICAL SHOCK HAZARD

Failure to turn off the main (remote) electrical disconnect device could result in personal injury or death.

Before installing, modifying or servicing system, turn OFF the main (remote) electrical disconnect device. There may be more than one disconnect device.

Supply voltage must be 208/230 volts (197 volt minimum to 253 volts maximum) 60 Hz single phase.

Outdoor units are approved for use with copper conductors only. Do not use aluminum wire.

Refer to unit rating plate for minimum circuit ampacity and circuit protection requirements.

Grounding

Permanently ground unit in accordance with the National Electrical Code and local codes or ordinances. Use a copper conductor of the correct size from the grounding lug in control box to a grounded connection in the service panel or a properly driven and electrically grounded ground rod.

Wiring Connections

Make all outdoor electrical supply (Line Voltage) connections with raintight conduit and fittings. Most codes require a disconnect switch outdoors within sight of the unit. Consult local codes for special requirements. Route electrical supply (Line Voltage) wiring through knockout hole in bottom of Control Box. Connect wires to Contactor and Ground Lug according to Wiring Diagram on unit. Refer to Figure 9.

Route thermostat wiring through rubber grommet in bottom of Control Box. Low voltage lead wires are provided in the control box for connection to thermostat wires (use wire nuts). Refer to Wiring Diagram on unit and Figure 10 for low voltage wiring examples.

NOTE: Use No. 18 AWG (American Wire Gage) color-coded, insulated (35 °C minimum) wire. If thermostat is located more than 100 feet (30.5 m) from unit as measured along the control voltage wires, use No.

16 AWG color-coded wires to avoid excessive voltage drop.

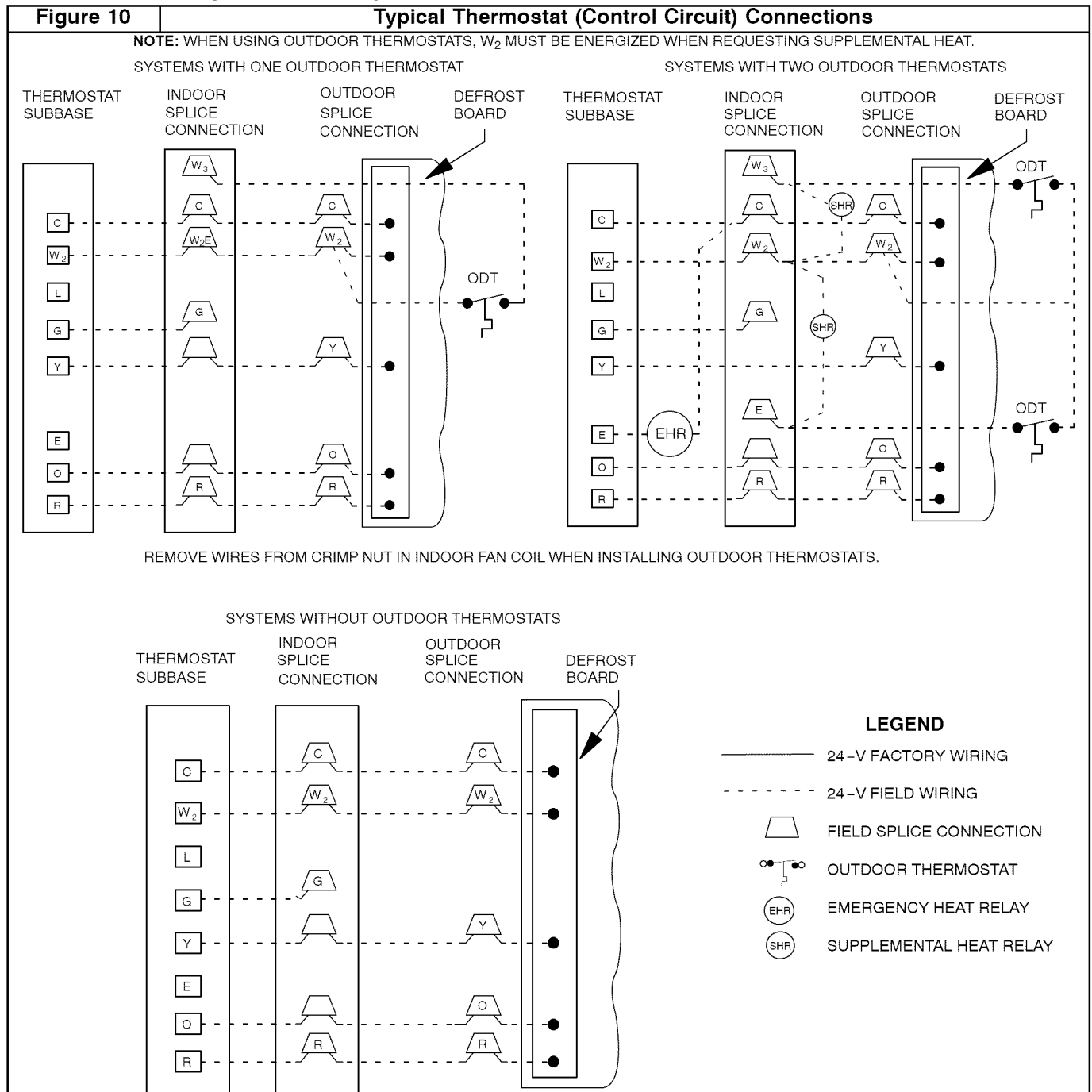
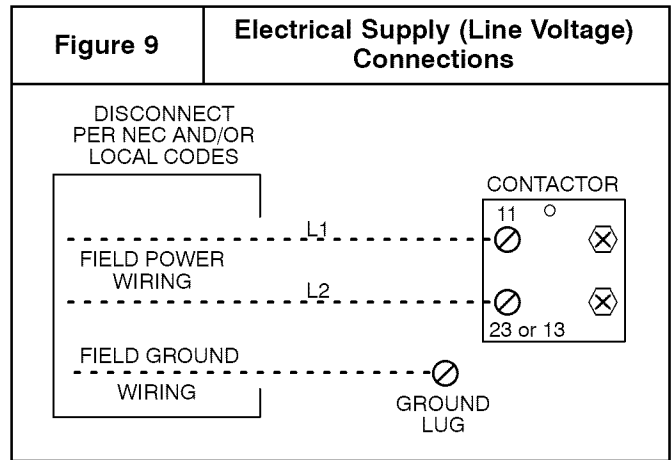

DEFROST SYSTEM

A. DEFROST THERMOSTAT

The defrost thermostat is factory installed on a short tube stub extending from the coil end plate. Refer to Figure 11 and confirm that the thermostat is securely fastened in place on the tube stub.

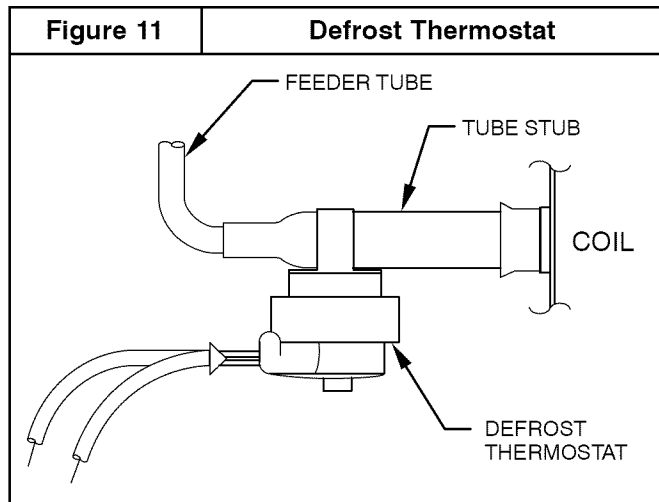

B. DEFROST CONTROL BOARD

The defrost board is a time/temperature control which includes a field-selectable time period between defrost cycles of 30, 60, or 90 minutes (quick-connects located at board edge, factory set at 60 or 90 minutes).

Defrost mode is identical to cooling mode except that outdoor-fan motor stops and second-stage heat is turned on to continue warming conditioned space.

Initially, the defrost cycle timer starts when the contactor is energized and a 24 VAC signal is present on the T1 terminal. Then the defrost cycle begins when the defrost thermostat is closed and the cycle timer times out (30, 60, 90 or minutes).

There are two **timers** involved in the defrost sequence:

Interval Timer – 30, 60, or 90 minutes, selected by setting the jumper on the defrost board. Timer is only active during calls for heating. Timer starts when the defrost thermostat closes 32° F (0°C). Timer stops when a defrost is initiated by the defrost board or when the defrost thermostat opens 65° F (18° C).

Defrost Timer – 10 minutes, not adjustable. Timer is only active while the coil is defrosting. Timer starts when the defrost board initiates a defrost. Timer stops when the defrost thermostat opens 65° F (18° C) or after timing out at 10 minutes (whichever comes first).

SPEEDUP pins are provided on the defrost board to help in troubleshooting without waiting for timers to expire. Jumpering the SPEEDUP pins causes any active timer to run very fast (256 times normal speed). Jumpering the SPEEDUP pins does not by itself initiate any timers, it only affects timers that are already running or are already part of the sequence.

To initiate a forced defrost cycle (test cycle), the defrost thermostat (Figure 11) must be closed.

There are two ways to verify that the defrost thermostat is closed:

1. Jumper across the DFT terminals on the defrost board (Figure 12). With this method, the defrost thermostat is removed from the circuit, and operation of the defrost thermostat itself will not be observed. Skip to #3.
2. Use a volt-meter to confirm there is no voltage across the DFT leads. 24 volts across the SFT terminals indicates an OPEN defrost thermostat. Zero volts across the DFT terminals indicates a CLOSED defrost thermostat.

With this method, the operation of the defrost thermostat can be observed during the test. If the defrost thermostat is confirmed closed, skip to #3.

If the defrost thermostat is open (24 volts across DFT leads) it may be possible to close the defrost thermostat by forcing a frost buildup on the outdoor coil. Follow these steps:

- Turn off power to unit.
 - Disconnect outdoor fan-motor lead from OF2 on control board (Figure 12). Tape lead to prevent grounding.
 - Restart unit in heating mode; wait for accumulation of frost on outdoor coil. Use volt-meter to confirm there are zero volts across the DFT leads (thermostat closed).
 - Turn off power to unit. Replace outdoor fan-motor lead to OF2 on control board (Figure 12). Restart the unit in heating mode.
3. With unit running in heating mode and the defrost thermostat closed, the entire defrost sequence can be sped up for testing by shorting together the SPEEDUP pins on the defrost board. Use a flat-headed screwdriver to short the pins together.
 4. Hold the SPEEDUP pins shorted together until the reversing valve shifts. SPEEDUP reduces whatever time was left on the interval timer (30/60/90 minutes). In normal operation the reversing valve will always shift with the SPEEDUP pins shorted for between 1 and 21 seconds.
 5. After shorting the SPEEDUP pins together as described in #4, the reversing valve will energize (shift to AC mode), the outdoor fan will stop, the strip heat will energize, and the coil will begin to defrost. There are two options for the defrost test:
 - a. Remove the short from between the SPEEDUP pins immediately after the reversing valve shifts, and the unit will defrost for a shortened period of time (something less than 10 minutes). The defrost will stop when the defrost thermostat opens (reaches 65° F)(18° C) or when the defrost timer times out (something less than 10 minutes).
 - b. Leave the SPEEDUP pins shorted together for more than 2 seconds after the reversing valve shifts, and the unit will immediately return to heating operation (#6 below). Continue to leave the pins shorted together and the sequence starts over at #4 above.
 6. Unit returns to heating mode after defrost sequence. Reversing valve shifts back, outdoor fan starts up, and strip heat de-energizes.

Figure 12

Defrost Control Board

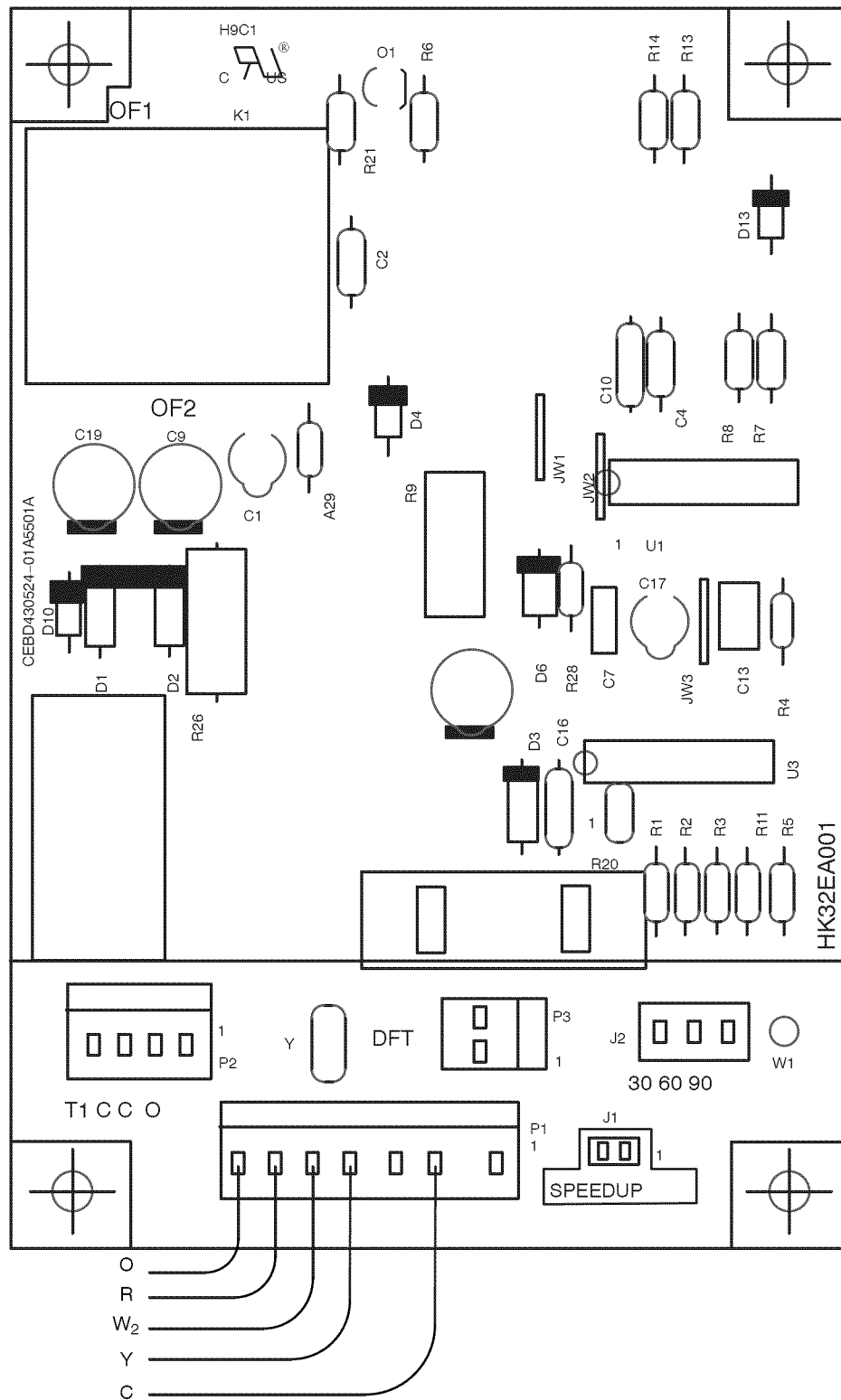

START-UP PROCEDURE

1. Set indoor thermostat selector switch to OFF.
2. Turn ON all electrical disconnect devices.
3. If unit has a crankcase heater, energize the heater and wait 24 hours before proceeding.
4. Set indoor thermostat at desired temperature. Be sure setpoint is below indoor ambient temperature to call for cooling, or above indoor ambient to call for heating.
5. Set indoor thermostat selector switch to COOL or HEAT. Operate unit for minimum 15 minutes, then check the system refrigerant charge.

REFRIGERANT CHARGE

Factory charge amount and desired subcooling are shown on unit rating plate. Charging method is shown on information plate inside unit. Additional subcooling may be required to achieve optimal heating performance based on installed indoor unit. (see figure 17)

For TXV, use subcooling method.

For Piston, use superheat method.

To properly check or adjust charge, conditions must be favorable for subcooling or superheat charging. Favorable conditions exist when the outdoor temperature is between 70°F and 100°F (21°C and 38°C), and the indoor temperature is between 70°F and 80°F (21°C and 27°C). Follow the procedure below.

Unit is factory charged for 15 feet (4.6m) of lineset. Adjust charge by adding or removing 0.6 oz/ft (17 g/mm) of 3/8 liquid line above or below 15 feet (4.6 m) respectively.

For standard refrigerant line lengths 80 feet (24.4m) or less, allow system to operate in cooling mode at least 15 minutes. If conditions are favorable, check system charge by super heat method for fixed metering device and subcooling method for TXV. If any adjustment is necessary, adjust charge slowly and allow system to operate for 15 minutes to stabilize before declaring a properly charged system.

If the indoor temperature is above 80°F (27°C), and the outdoor temperature is in the favorable range, adjust system charge by weight based on line length and allow the indoor temperature to drop to 80°F (27°C) before attempting to check system charge by subcooling method as described above.

If the indoor temperature is below 70°F (21°C), or the outdoor temperature is not in the favorable range, adjust charge for line set length above or below 15 feet (4.6m) only. Charge level should then be appropriate for the system to achieve rated capacity. The charge level could then be checked at another time when the both indoor and outdoor temperatures are in a more favorable range.

NOTE: If line length is beyond 80 feet (24.4m) or greater than 20 feet (6.1m) vertical separation, See Long Line Guideline for special charging requirements.

A. UNITS WITH COOLING MODE TXV

Units installed with cooling mode TXV require charging by the subcooling method.

1. Operate unit a minimum of 15 minutes before checking charge.

NOTE: If outdoor unit has a 2-speed fan motor, motor will operate in low speed when outdoor ambient temperature is below 82°F (28°C). Pull the BRN/YEL low voltage wire off the fan control and the unit will default to high speed fan for servicing. Reconnect wire after servicing.

2. Measure liquid service valve pressure by attaching an accurate gage to service port.
3. Measure liquid line temperature by attaching an accurate thermistor type or electronic thermometer to liquid line near outdoor coil.
4. Refer to unit rating plate for required subcooling temperature.
5. Refer to Figure 15. Find the point where required subcooling temperature intersects measured liquid service valve pressure.
6. To obtain required subcooling temperature at a specific liquid line pressure, add refrigerant if liquid line temperature is higher than indicated or reclaim refrigerant if temperature is lower. Allow a tolerance of $\pm 3^{\circ}\text{F}$ ($\pm 1.7^{\circ}\text{C}$).

B. UNITS WITH INDOOR PISTON

Units installed with indoor pistons require charging by the superheat method.

The following procedure is valid when indoor airflow is within ± 21 percent of its rated CFM.

1. Operate unit a minimum of 15 minutes before checking charge.
2. Measure suction pressure by attaching an accurate gage to suction valve service port.
3. Measure suction temperature by attaching an accurate thermistor type or electronic thermometer to suction line at service valve.
4. Measure outdoor air dry-bulb temperature with thermometer.
5. Measure indoor air (entering indoor coil) wet-bulb temperature with a sling psychrometer.
6. Find outdoor temperature and evaporator entering air wet-bulb temperature. At this intersection, note superheat. Where a dash (--) appears on the table, do not attempt to charge system under these conditions or refrigerant slugging may occur. Charge must be weighted in, adding or removing 0.6 oz/ft of 3/8 liquid line above or below 15 feet (4.6m) respectively.
7. Find superheat temperature (from #6 above) and suction pressure. At this intersection, note suction line temperature.
8. If unit has a higher suction line temperature than charted temperature, add refrigerant until charted temperature is reached.
9. If unit has a lower suction line temperature than charted temperature, reclaim refrigerant until charted temperature is reached.
10. When adding refrigerant, charge in liquid form into suction service port using a flow-restricting device.

11. If outdoor air temperature or pressure at suction valve changes, charge to new suction line temperature indicated on chart.
12. **Optimum performance will be achieved when the operating charge produces 5° to 6°F suction superheat at suction service valve with 82°F (28°C) outdoor ambient and 80°F (27°C) dry bulb (67°F / 19°C) wet bulb indoor temperature (DOE "B" test conditions) at rated airflow.**

C. HEATING MODE

To check system operation during heating cycle, refer to the Tech Label on outdoor unit. This chart indicates whether a correct relationship exists between system operating pressure and air temperature entering indoor and outdoor units. If pressure and temperature do not match on chart, system refrigerant charge may not be correct. Do not use chart to adjust refrigerant charge.

NOTE: When charging is necessary during heating season, charge must be weighed in accordance with unit rating plate ± 0.6 ounces per foot of a inch liquid line above or below 15 feet respectively (± 17 g per 305mm of 10mm liquid line above or below 4.6m respectively).

SEQUENCE OF OPERATION

A. COOLING MODE

On a call for cooling, the thermostat makes circuits R-O, R-Y, and R-G. Circuit R-O energizes reversing valve, switching it to cooling position. Circuit R-Y energizes contactor, starting outdoor fan motor and compressor. Circuit R-G energizes indoor unit blower relay, starting indoor blower motor.

When thermostat is satisfied, its contacts open, de-energizing contactor and blower relay. Compressor and motors stop.

NOTE: If indoor unit is equipped with a time-delay relay circuit, the blower runs an additional length of time to increase system efficiency. (Applies to both cooling and heating modes.)

B. HEATING MODE

On a call for heating, the thermostat makes circuits R-Y and R-G (circuit R-O is NOT made, and the reversing valve stays in the de-energized, heating position). Circuit R-Y energizes contactor, starting outdoor fan motor and compressor. Circuit R-G energizes indoor blower relay, starting blower motor. If the room temperature continues to fall, circuit R-W2 is made through the second-stage room thermostat bulb. Circuit R-W2 energizes a sequencer, bringing on the first bank supplemental electric heat and providing electrical potential to the second heater sequencer (if used). If outdoor temperature falls below the setting of the outdoor thermostat (field-installed option), contacts close to complete the circuit and bring on the second bank of supplemental electric heat.

When the thermostat is satisfied, its contacts open, de-energizing contactor, blower relay, and sequencer. Compressor, motors, and heaters stop.

Figure 13	SUPERHEAT CHARGING TABLE °F														SUPERHEAT CHARGING TABLE °C														
	EVAPORATOR ENTERING AIR °F AT WB														EVAPORATOR ENTERING AIR °C AT WB														
	°F	50	52	54	56	58	60	62	64	66	68	70	72	74	76	°C	10	11	12	13	14	16	17	18	19	20	21	22	23
Outdoor Temp	SUPERHEAT °F AT LOW-SIDE SERVICE PORT														Outdoor Temp	SUPERHEAT °C AT LOW-SIDE SERVICE PORT													
55	9	12	14	17	20	23	26	29	32	35	37	40	42	45	13	5	7	8	9	11	13	14	16	18	19	21	22	23	25
60	7	10	12	15	18	21	24	27	30	33	35	38	40	43	16	4	6	7	8	10	12	13	15	17	18	19	21	22	24
65	-	6	10	13	16	19	21	24	27	30	33	36	38	41	18	-	3	6	7	9	11	12	13	15	17	18	20	21	23
70	-	-	7	10	13	16	19	21	24	27	30	33	36	39	21	-	-	4	6	7	9	11	12	13	15	17	18	20	22
75	-	-	-	6	9	12	15	18	21	24	28	31	34	37	24	-	-	-	3	5	7	8	10	12	13	16	17	19	21
80	-	-	-	-	5	8	12	15	18	21	25	28	31	35	27	-	-	-	-	3	4	7	8	10	12	14	16	17	19
85	-	-	-	-	-	-	8	11	15	19	22	26	30	33	29	-	-	-	-	-	-	4	6	8	11	12	14	17	18
90	-	-	-	-	-	-	5	9	13	16	20	24	27	31	32	-	-	-	-	-	-	3	5	7	9	11	13	15	17
95	-	-	-	-	-	-	-	6	10	14	18	22	25	29	35	-	-	-	-	-	-	-	3	6	8	10	12	14	16
100	-	-	-	-	-	-	-	-	8	12	15	20	23	27	38	-	-	-	-	-	-	-	-	4	7	8	11	13	15
105	-	-	-	-	-	-	-	-	5	9	13	17	22	26	41	-	-	-	-	-	-	-	-	3	5	7	9	12	14
110	-	-	-	-	-	-	-	-	-	6	11	15	20	25	43	-	-	-	-	-	-	-	-	-	3	6	8	11	14
115	-	-	-	-	-	-	-	-	-	-	8	14	18	23	46	-	-	-	-	-	-	-	-	-	-	4	8	10	13

*Optimum performance point, 95°F (35°C) outdoor ambient and (80°F / 27°C dry bulb), (67°F / 19°C wet bulb) indoor conditions. (DOE A Test Conditions)
 Where a dash (-) appears do not attempt to charge system under these conditions or refrigerant slugging may occur. Charge must be weighed in.

Note: Superheat °F is at low-side service port, Allow a tolerance of ± 3°F (± 1.7°C)
Note: Indoor dry bulb between 70°F and 80°F (21°C and 27°C)

Figure 14	SUCTION PRESSURE AT SERVICE PORT PSIG										SUCTION PRESSURE AT SERVICE PORT kPa									
	SUPER-HEAT TEMP °F	108	112	117	121	126	131	139	141	146	SUPER-HEAT TEMP °C	743	774	805	836	869	902	957	971	1005
		REQUIRED SUCTION TUBE TEMPERATURE °F (MEASURED AT LOW-SIDE SERVICE PORT)										REQUIRED SUCTION TUBE TEMPERATURE °C (MEASURED AT LOW-SIDE SERVICE PORT)								
0	35	37	39	41	43	45	47	49	51	0	2	3	4	5	6	7	8	9	11	
2	37	39	41	43	45	47	49	51	53	1	3	4	5	6	7	8	9	11	12	
4	39	41	43	45	47	49	51	53	55	2	4	5	6	7	8	9	11	12	13	
6	41	43	45	47	49	51	53	55	57	3	5	6	7	8	9	11	12	13	14	
8	43	45	47	49	51	53	55	57	59	4	6	7	8	9	11	12	13	14	15	
10	45	47	49	51	53	55	57	59	61	6	7	8	9	11	12	13	14	15	16	
12	47	49	51	53	55	57	59	61	63	7	8	9	11	12	13	14	15	16	17	
14	49	51	53	55	57	59	61	63	65	8	9	11	12	13	14	15	16	17	18	
16	51	53	55	57	59	61	63	65	67	9	11	12	13	14	15	16	17	18	19	
18	53	55	57	59	61	63	65	67	69	10	12	13	14	15	16	17	18	19	21	
20	55	57	59	61	63	65	67	69	71	11	13	14	15	16	17	18	19	21	22	
22	57	59	61	63	65	67	69	71	73	12	14	15	16	17	18	19	21	22	23	
24	59	61	63	65	67	69	71	73	75	13	15	16	17	18	19	21	22	23	24	
26	61	63	65	67	69	71	73	75	77	14	16	17	18	19	21	22	23	24	25	
28	63	65	67	69	71	73	75	77	79	16	17	18	19	21	22	23	24	25	26	
30	65	67	69	71	73	75	77	79	81	17	18	19	21	22	23	24	25	26	27	

Figure 15	Rating Plate (required) Subcooling Temperature °F (°C)											
	°F 6	(°C) 3	°F 8	(°C) 4	°F 10	(°C) 6	°F 12	(°C) 7	F 14	(°C) 8	F 16	(°C) 9
Measured Liquid Pressure (psig)	R-410A Required Liquid Line Temperature °F (°C)											
	251	78	26	76	24	74	23	72	22	70	21	68
259	80	27	78	26	76	24	74	23	72	22	70	21
266	82	28	80	27	78	26	76	24	74	23	72	22
274	84	29	82	28	80	27	78	26	76	24	74	23
283	86	30	84	29	82	28	80	27	78	26	76	24
291	88	31	86	30	84	29	82	28	80	27	78	26
299	90	32	88	31	86	30	84	29	82	28	80	27
308	92	33	90	32	88	31	86	30	84	29	82	28
317	94	34	92	33	90	32	88	31	86	30	84	29
326	96	36	94	34	92	33	90	32	88	31	86	30
335	98	37	96	36	94	34	92	33	90	32	88	31
345	100	38	98	37	96	36	94	34	92	33	90	32
364	104	40	102	39	100	38	98	37	96	36	94	34
374	106	41	104	40	102	39	100	38	98	37	96	36
384	108	42	106	41	104	40	102	39	100	38	98	37
395	110	43	108	42	106	41	104	40	102	39	100	38
406	112	44	110	43	108	42	106	41	104	40	102	39
416	114	46	112	44	110	43	108	42	106	41	104	40
427	116	47	114	46	112	44	110	43	108	42	106	41
439	118	48	116	47	114	46	112	44	110	43	108	42
450	120	49	118	48	116	47	114	46	112	44	110	43
462	122	50	120	49	118	48	116	47	114	46	112	44
474	124	51	122	50	120	49	118	48	116	47	114	46

Figure 16 - Additional Subcooling

Indoor Models	15 SEER							13 & 14 SEER						
	Subcooling Delta from Rating Plate Value							Subcooling Delta from Rating Plate Value						
	OUTDOOR UNIT TONNAGE							OUTDOOR UNIT TONNAGE						
	18	24	30	36	42	48	60	18	24	30	36	42	48	60
ED*4X18B**/EA*4X18*14A*	--							--						
EN(A,D)4X18*14**	--							--						
FEM4(P,X)18**A*+TXV	--							--						
F(E,S)A4X18**A*	--							--						
FXM4X18**A*	--							+3						
FS(M,U)4P18**A*+TXV	--							--						
ED*4X24***/EA*4X24*(14,17)A*	--	--						+3	+3					
EN*4X24*****	--	--						+3	+3					
EHD4X24A**	--	--						+5	+5					
FEM4P24**A*+TXV	--	--						--	--					
F(E,S)A4X24**A*	--	--						+5	+3					
(FVM/FCM)4X24****	+3	--	--					+5	+3	+3				
FXM4X24**A*	--	--						+5	+3					
FEM4X24**A*	--	--						+3	+3					
FS(M,U)4P24**A*+TXV	--	--						+5	+3					
ED*4X30***/EA*4X30*(14,17)A*		--	-						+3	--				
EN*4X30*****		--	-						+3	+3				
EHD4X30A**		--	-						+3	+3				
FEM4(P,X)30**A*+TXV		--	-						+3	--				
FSA4X30**A*		--	-						+3	--				
FEA4X30**A*		--	-						+3	--				
FXM4X30**A*		+3	-						+5	+5				
FS(M,U)4P30**A*+TXV		+3	-						+5	+5				
(FVM/FCM)4X36****			--	--						+5	+3			
ED*4X36***/EA*4X36*(14,17,21)A*			--	--						+5	+3			
EN*4X36*****			--	--						+3	--			
EHD4X36A**			--	--						+5	+3			
FEM4P36**A*+TXV			--	--						--	--			
FSA4X36**A*			--	--						+5	+3			
FEA4X36**A*			--	--						+5	+3			
F(E,X)M4X36**A*			+5	--						+5	+5			
FS(M,U)4P36**A*+TXV			--	--						+5	+3			
ED*4X42***/EA*4X42*(21,24)A*				--	--						+3	--		
EN*4X42*21**				--	--						+3	--		
END4X42*17**				--	--						+3	--		
EHD4X42A**				--	--						+5	--		
FEM4(P,X)42**A*+TXV				--	--						+5	--		
FXM4X42**A*				--	--						+5	--		
FS(M,U)4P42**A*+TXV				--	--						+5	--		
ED*4X48F**/EA*4X48*17A*					+5	--						+5	+3	
ED*4X48(J,L)**/EA*4X48*(21,24)A*					+3	--						+3	--	
EN*4X48*****					--	--						--	--	
EHD4X48A**					--	--						+3	--	
FEM4P48**A*+TXV					--	--						--	--	
(FVM/FCM)4X48****			+3	+3	+3	-	--				+5	+5	+3	--
F(E,X)M4X48**A*					+3	--						+3	--	
FS(M,U)4P48**A*+TXV					+3	--						+3	--	
ED*4X60***/EA*4X60*(21,24)A*						+5	--						+5	+3

Figure 17 - Additional Subcooling Tables

	15 SEER						13 & 14 SEER							
	Subcooling Delta from Rating Plate Value						Subcooling Delta from Rating Plate Value							
	OUTDOOR UNIT TONNAGE						OUTDOOR UNIT TONNAGE							
Indoor Models	18	24	30	36	42	48	60	18	24	30	36	42	48	60
EN*4X60*24**						--	--						+3	--
EHD4X60A**						+3	-						+5	+3
FEM4X60**B*						--	-						+5	--
(FVM/FCM)4X60****				+5	+5	+3	-				+5	+5	+5	+3
FXM4X60**A*						+3	--						+5	+3
FS(M,U)4X60**A*						+3	--						+5	+3

TROUBLESHOOTING

Some models are factory equipped with the Comfort Alert™ Diagnostics device in the control box (refer to Figure 17). Comfort Alert provides around-the-clock monitoring for common electrical problems, compressor defects, and broad system faults. If trouble is detected, an alert code is displayed with a flashing LED indicator. Alert codes are listed in Figure 18.

The device is factory wired and requires no modification. Low voltage lead wires are provided in the control box for connection to thermostat wires (use wire nuts).

The Comfort Alert device operates by monitoring the compressor power leads and the thermostat demand signal (Y terminal). It draws constant 24 VAC power at the R and C terminals.

MAINTENANCE

Condensate Drain

During the cooling season, check monthly for free flow of drainage and clean if necessary.

Cleanliness

These tips will help keep the heat pump looking better and working more efficiently:

- Free flow of air is essential. Keep fences, shrubs, trash cans, and other obstructions at least 18 inches (457mm) from all coil inlets.
- Keep the coil free of grass clippings, leaves, weeds, and other debris.
NOTE: Coil may occasionally require cleaning with a liquid solution. The coil must be cold when cleaning. Use an alkaline based cleaner only. Cleaning a hot coil or using an acid based cleaner will remove the paint from the fins and may clog the coil.
- Never use a weather cover over the outdoor unit unless it is a ventilated type or made of breathable fabric that will allow moisture to evaporate rapidly. A cover that holds moisture in the unit will cause more rust build-up and damage than normal exposure to weather.

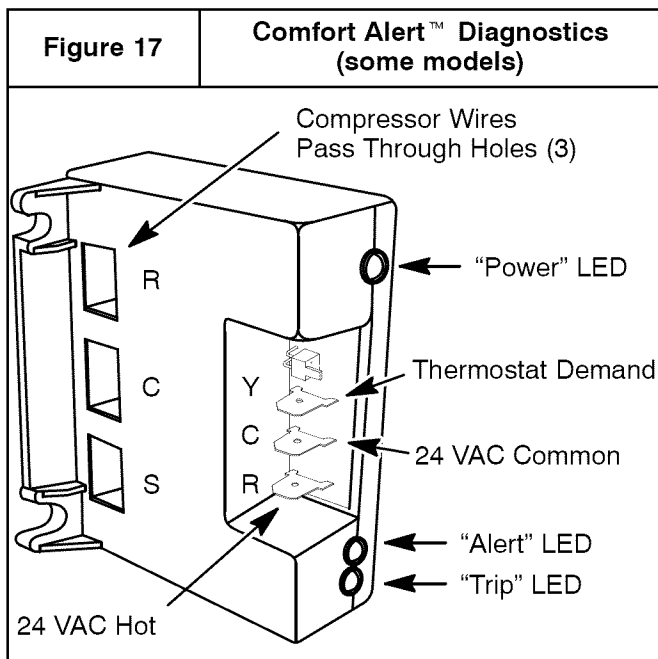

Figure 18		Comfort Alert™ Diagnostics (some models)	
Status LED	Status LED Description	Status LED Troubleshooting Information	
Green "POWER"	Module has power	Supply voltage is present at module terminals	
Red "TRIP"	Thermostat demand signal Y1 is present, but the compressor is not running	<ol style="list-style-type: none"> 1. Compressor protector is open 2. Outdoor unit power disconnect is open 3. Compressor circuit breaker or fuse(s) is open 4. Broken wire or connector is not making contact 5. Low pressure switch open if present in system 6. Compressor contactor has failed open 	
Yellow "ALERT" Flash Code 1	Long Run Time Compressor is running extremely long run cycles	<ol style="list-style-type: none"> 1. Low refrigerant charge 2. Evaporator blower is not running 3. Evaporator coil is frozen 4. Faulty metering device 5. Condenser coil is dirty 6. Liquid line restriction (filter drier blocked if present in system) 7. Thermostat is malfunctioning 	
Yellow "ALERT" Flash Code 2	System Pressure Trip Discharge or suction pressure out of limits or compressor overloaded	<ol style="list-style-type: none"> 1. High head pressure 2. Condenser coil poor air circulation (dirty, blocked, damaged) 3. Condenser fan is not running 4. Return air duct has substantial leakage 5. If low pressure switch present in system, check Flash Code 1 information 	
Yellow "ALERT" Flash Code 3	Short Cycling Compressor is running only briefly	<ol style="list-style-type: none"> 1. Thermostat demand signal is intermittent 2. Time delay relay or control board defective 3. If high pressure switch present go to Flash Code 2 information 4. If low pressure switch present go to Flash Code 1 information 	
Yellow "ALERT" Flash Code 4	Locked Rotor	<ol style="list-style-type: none"> 1. Run capacitor has failed 2. Low line voltage (contact utility if voltage at disconnect is low) 3. Excessive liquid refrigerant in compressor 4. Compressor bearings are seized 	
Yellow "ALERT" Flash Code 5	Open Circuit	<ol style="list-style-type: none"> 1. Outdoor unit power disconnect is open 2. Compressor circuit breaker or fuse(s) is open 3. Compressor contactor has failed open 4. High pressure switch is open and requires manual reset 5. Open circuit in compressor supply wiring or connections 6. Unusually long compressor protector reset time due to extreme ambient temperature 7. Compressor windings are damaged 	
Yellow "ALERT" Flash Code 6	Open Start Circuit Current only in run circuit	<ol style="list-style-type: none"> 1. Run capacitor has failed 2. Open circuit in compressor start wiring or connections 3. Compressor start winding is damaged 	
Yellow "ALERT" Flash Code 7	Open Run Circuit Current only in start circuit	<ol style="list-style-type: none"> 1. Open circuit in compressor run wiring or connections 2. Compressor run winding is damaged 	
Yellow "ALERT" Flash Code 8	Welded Contactor Compressor always runs	<ol style="list-style-type: none"> 1. Compressor contactor has failed closed 2. Thermostat demand signal not connected to module 	
Yellow "ALERT" Flash Code 9	Low Voltage Control circuit < 17VAC	<ol style="list-style-type: none"> 1. Control circuit transformer is overloaded 2. Low line voltage (contact utility if voltage at disconnect is low) 	

- Flash Code number corresponds to a number of LED flashes, followed by a pause and then repeated.
- TRIP and ALERT LEDs flashing at same time means control circuit voltage is too low for operation.
- Reset ALERT Flash code by removing 24VAC power from module.
- Last ALERT Flash code is displayed for 1 minute after module is powered on.

R-410A QUICK REFERENCE GUIDE

- R-410A refrigerant operates at 50% – 70% higher pressures than R-22. Be sure that servicing equipment and replacement components are designed to operate with R-410A.
- R-410A refrigerant cylinders are rose colored.
- Recovery cylinder service pressure rating must be 400 psig, DOT 4BA400 or DOT BW400.
- R-410A systems should be charged with liquid refrigerant. Use a commercial type metering device in the manifold hose.
- Manifold sets should be 750 psig high-side and 200 psig low-side with 520 psig low-side retard.
- Use hoses with 750 psig service pressure rating.
- Leak detectors should be designed to detect HFC refrigerant.
- R-410A, as with other HFC refrigerants, is only compatible with POE oils.
- Vacuum pumps will not remove moisture from oil.
- Do not use liquid line filter-driers with rated working pressures less than 600 psig.
- Do not install a suction line filter-drier in liquid line.
- POE oils absorb moisture rapidly. Do not expose oil to atmosphere.
- POE oils may cause damage to certain plastics and roofing materials.
- Wrap all filter-driers and service valves with wet cloth when brazing.
- A liquid line filter-drier is required on every unit.
- Do not use with an R-22 TXV.
- If indoor unit is equipped with an R-22 TXV, it must be changed to an R-410A TXV.
- Never open system to atmosphere while it is under a vacuum.
- When system must be opened for service, break vacuum with dry nitrogen and replace all filter-driers.
- Do not vent R-410A into the atmosphere.
- Do not use capillary tube indoor coils.
- Observe all **WARNINGS, CAUTIONS, NOTES**, and **bold** text.