

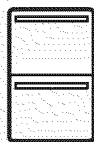

Thinking of you
Electrolux



EN REFRIGERATED DRAWERS
FR TIROIRS RÉFRIGÉRÉS
ES CAJONES REFRIGERADOS

USE AND CARE GUIDE
GUIDE D'UTILISATION ET D'ENTRETIEN
GUIA DE USO Y CUIDADO



2 Finding Information

Please Read and Save This Guide

Thank you for choosing Electrolux, the new premium brand in home appliances. This Use & Care Guide is part of our commitment to customer satisfaction and product quality throughout the service life of your new Refrigerated Drawers.

We view your purchase as the beginning of a relationship. To ensure our ability to continue serving you, please use this page to record key product information.



IMPORTANT

PLEASE READ all instructions completely before attempting to install or operate the unit.

All Refrigerated Drawers require a connection to an electrical power source. Improper hook-up can result in a safety hazard and potential damage to the product or contents! Proper installation, in accordance with the manufacturer's specifications and all local codes, is the sole responsibility of the consumer. The manufacturer is not responsible for any installation expenses or damages incurred due to improper installation. If you are unsure of your ability to safely connect electric power to the unit, consult a licensed and insured professional to perform all electrical work.

Once you have your unit installed, we suggest you keep this manual in a safe place for future reference. Should any problems occur, refer to the "Troubleshooting" section of this manual. This information will help you quickly identify a problem and get it remedied. In the event you require assistance, please contact the dealer where you purchased your unit.

Make a Record for Quick Reference

Whenever you call to request information or service, you will need to know your model number and serial number. You can find this information on the serial plate located on the bottom left hand corner of your unit and on the product registration card.

Product Registration Card

The package containing this manual also includes your product registration information. Warranty coverage begins at the time your Electrolux Refrigerated Drawers was purchased.



NOTE

Registering your product with Electrolux enhances our ability to serve you. You can register online at www.electroluxappliances.com or by dropping your Product Registration Card in the mail. Complete and mail the Product Registration Card as soon as possible to validate the registration date.

Please record the purchase date of your Electrolux unit and your dealer's name, address and telephone number.

Purchase Date

Electrolux Model Number

Electrolux Serial Number

Dealer Name

Dealer Address

Dealer Telephone

Keep this manual and the sales receipt together in a safe place for further reference.

Questions?

For toll-free telephone support in the U.S. and Canada: 1-877- 4ELECTROLUX (1-877-435-3287)

For online support and Internet product information: www.electroluxappliances.com

Table of Contents

Finding Information	2
Please Read and Save This Guide	2
Make a Record for Quick Reference	2
Product Registration Card	2
Questions?	2
Safety	4
Important Safety Instructions	4
Safety Precautions	4
Definitions	4
General Precautions	4
Installation	5
Installing the Refrigerated Drawers	5
Site Preparation	6
Installing the Anti-Tip Device	6
Leveling	8
Leveling the Unit	8
Operation	9
Temperature Mode	10
Alarms	11
Vacation/Sabbath Mode	12
Removing the Drawer	13
Care and Cleaning and Energy Saving Tips	14
Maintenance	15
Maintaining Your Refrigerated Drawers	15
Exterior Cleaning for Your Stainless Steel Model	15
Interior Cleaning	15
Troubleshooting	16
Before You Call for Service	17
If Service is Required	17
Warranty Information	18

4 Safety

Important Safety Instructions

Safety Precautions

Do not attempt to install or operate your unit until you have read the safety precautions in this manual. Safety items throughout this manual are labeled with a Danger, Warning or Caution based on the risk type.

Definitions

 This is the safety alert symbol. It is used to alert you to potential personal injury hazards. Obey all safety messages that follow this symbol to avoid possible injury or death.



DANGER

DANGER indicates an imminently hazardous situation which, if not avoided, will result in death or serious injury.



WARNING

WARNING indicates a potentially hazardous situation which, if not avoided, could result in death or serious injury.



CAUTION

CAUTION indicates a potentially hazardous situation which, if not avoided, may result in minor or moderate injury.



IMPORTANT

Indicates installation, operation, or maintenance information which is important but not hazard-related.

General Precautions



WARNING

RISK OF CHILD ENTRAPMENT. Before you throw away your old appliance, take off the drawers and leave shelves in place so that children may not easily climb inside.



WARNING

- Never attempt to repair or perform maintenance on the unit until the electricity has been disconnected.
- Altering, cutting of power cord, removal of power cord, removal of power plug, or direct wiring can cause serious injury, fire and/or loss of property and/or life and will void the warranty.
- Do not lift unit by drawer handle.



CAUTION

- Use care when moving the unit. Some edges are sharp and may cause personal injury. Wear gloves when moving or repositioning the unit.
- Never install the unit behind closed drawers. Be sure front grille is free of obstruction. Obstructing air flow can cause the unit to malfunction, and may void the warranty.
- Allow unit temperature to stabilize for 24 hours before use.



CAUTION

- Use only genuine Electrolux replacement parts. Imitation parts can damage the unit and may void the warranty.

Installing the Refrigerated Drawers

Your Electrolux Refrigerated Drawer unit has been designed for either free-standing or built-in installation. When built-in, your Refrigerated Drawers does not require additional air space for top, sides or rear. In either case, the front grille must **NOT** be obstructed.

NOTE

To ease unit installation and removal, it is recommended that the cabinet rough opening dimensions be increased by at least 1/4 inch over the dimensions given for your unit.

NOTE

All units require zero clearance when installed flush with a cabinet or wall. Electrolux stainless steel models require a minimum 2 7/8 inch handle clearance when installed against a wall or cabinet that extends beyond the front edge of the unit.

Unit Dimensions

Width	Height	Depth
23 7/8 inch	33 3/4 - 34 3/4 inches	26 3/8 inch

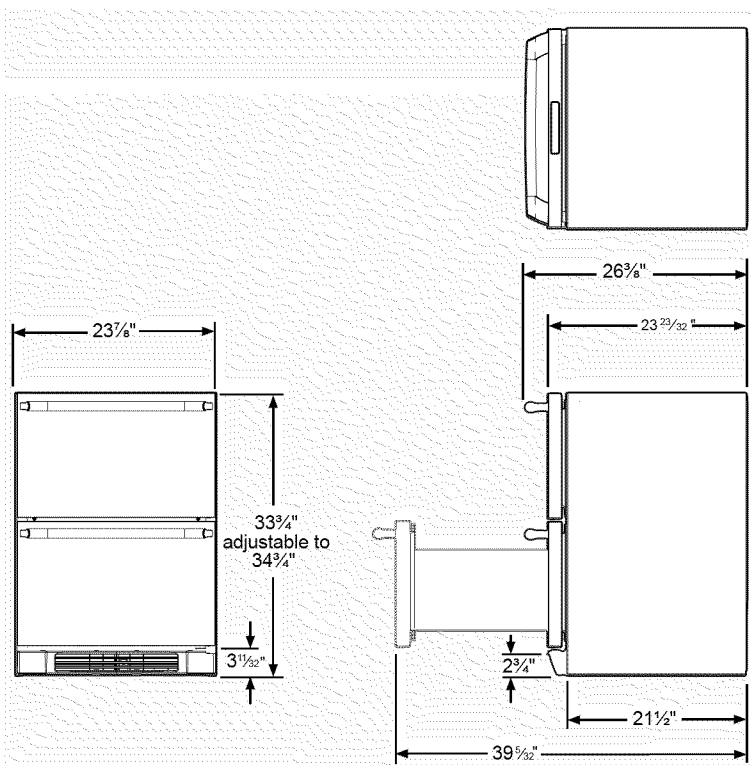

Product Dimensions

6 Installation

Site Preparation

- 1 Position the unit on a flat, level surface capable of supporting the entire weight of the unit. Remember the unit will be significantly heavier once it is fully loaded.
- 2 This unit requires a grounded and polarized 115 VAC, 60Hz, 15A circuit (normal household current).
- 3 Avoid connecting the unit to a Ground Fault Interrupter (GFI). GFIs are prone to nuisance tripping which will cause the unit to shut down. GFIs are generally not used on circuits which power equipment that must run unattended for long periods of time.
- 4 The unit must be installed according to your state and local laws and regulations.



WARNING

ELECTROCUTION HAZARD!

Electrical Grounding Required. This appliance is equipped with a three prong (grounding) polarized plug for your protection against possible shock hazards.

- NEVER remove the round grounding prong from the plug.
- NEVER use a two-prong grounding adapter.
- NEVER use an extension cord to connect power to the unit.

Where a two-prong wall receptacle is encountered or a longer power cord is required, contact a qualified electrician to have it replaced in accordance with applicable electrical codes.

- 5 Position the unit to allow free air flow through the front grille.

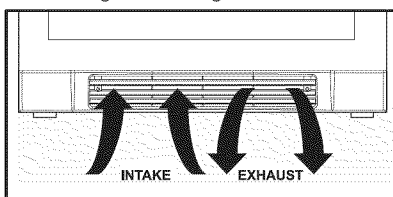

- 6 Wipe out inside of unit with a damp cloth.
- 7 Be sure to install the Anti-Tip bracket. Follow the instructions provided with the Anti-Tip bracket kit.

Installing the Anti-Tip Device



WARNING

Do not double stack two units as shown below. This may cause serious personal injury.

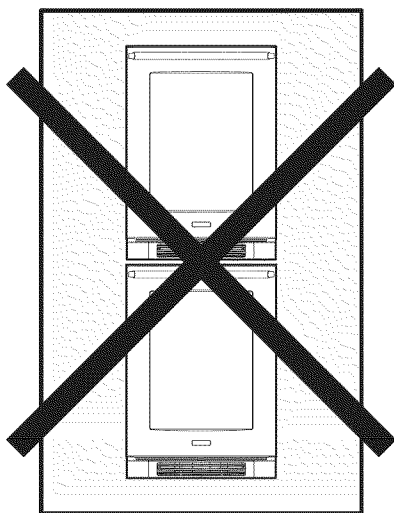

CAUTION

If your Refrigerated Drawers are not located under a counter top (free standing), you must use an anti-tip device installed as per these instructions. If the Refrigerated Drawers are removed from their location for any reason, make sure that the device is properly engaged when you push the Refrigerated Drawers back into the original location. If the device is not properly engaged, there is a risk of the Refrigerated Drawers tipping over, causing property or personal injury if you or a child stand, sit, or lean on an open drawer.



NOTE

If installing on a concrete floor, concrete fasteners are required, (not included with the anti-tip kit).



CAUTION

Any finished flooring should be protected with appropriate material to avoid damage when moving the unit.



WARNING

- ALL DRAWERS CAN TIP
- INJURY COULD RESULT
- INSTALL ANTI-TIP BRACKET PACKED WITH UNIT
- SEE INSTRUCTIONS

Floor Mount Installation

The anti-tip bracket is to be located on the floor in the left or right rear corner of the Refrigerated Drawers as shown in Figure 6.

Step by step instructions for locating the position of the bracket:

- 1 Decide where you want to place the Refrigerated Drawers. Slide them into place, being careful not to damage the floor, leaving 1" (2.5 cm) of clearance from the rear wall to allow room for the anti-tip bracket.
- 2 Raise the rear leveling legs approximately ¼" (6 mm) to allow engagement with the anti-tip bracket. Level the unit by adjusting all the leveling legs as required. Turning the leveling leg counterclockwise will raise the unit and clockwise will lower the unit.

- 3 Make sure the Refrigerated Drawers are in the desired location, then mark on the floor the rear and side corner of the cabinet where the anti-tip bracket will be installed. If the installation does not allow marking the rear corner of the cabinet, then make temporary lines on the floor marking the front corner of the cabinet, excluding the drawer. Slide the Refrigerated Drawers out of the way. From the temporary line extend the sidewall line back 21½" (54.6cm) as shown in Figure 7.
- 4 Align the anti-tip bracket to the marks on the floor so the side of the bracket lines up with the side of the cabinet mark, and the "V" notches on the anti-tip bracket line up with the end of the 21½" (54.6cm) line (Rear of cabinet line).
- 5 Fasten the anti-tip bracket to the floor using the supplied screw. (See Figure 7).
- 6 Slide the cabinet back into position, making sure the rear cabinet leveling leg slides under the anti-tip bracket engaging the slot.

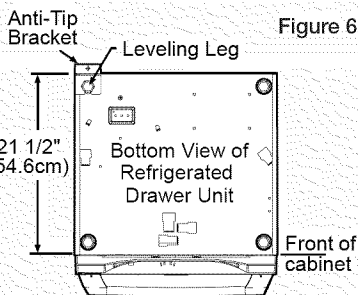
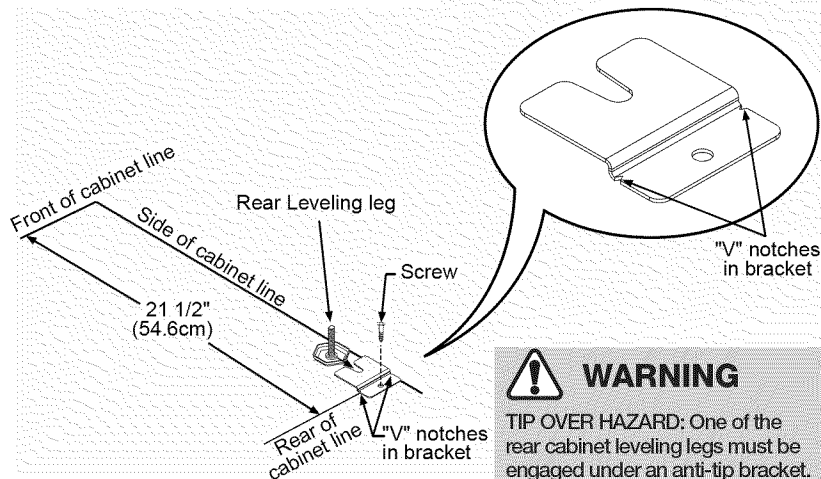

Figure 6



WARNING

TIP OVER HAZARD: One of the rear cabinet leveling legs must be engaged under an anti-tip bracket.

8 Leveling

Leveling the Unit

Position the unit on a flat, level surface capable of supporting the entire weight of the unit when full.

Leveling Legs

Adjustable legs at the front and rear corners of the appliance should be set so the unit is firmly positioned on the floor and level from side to side and front to back. The overall height of your Electrolux appliance may be adjusted between the minimum, 33 $\frac{3}{4}$ " (85.7cm), by turning the leveling leg in and the maximum, 34 $\frac{3}{4}$ " (88.3cm), by turning the leveling leg out. See Figure 2 and 2a.

To adjust the leveling legs, place the appliance on a solid surface and protect the floor beneath the legs to avoid scratching the floor. With the assistance of another person, lean the appliance back to access the front leveling legs. Raise or lower the legs to the required dimension by turning the legs. Repeat this process for the rear by tilting the appliance forward using caution. On a level surface check the appliance for levelness and adjust accordingly.

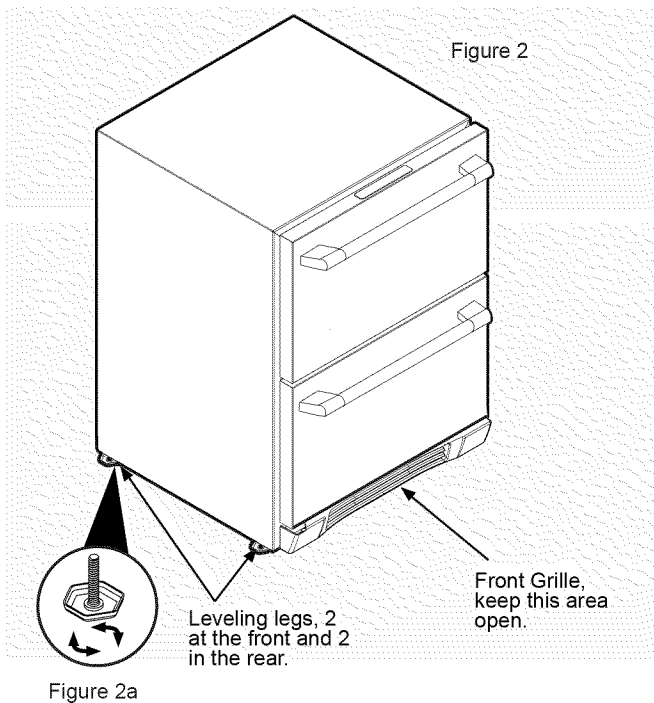

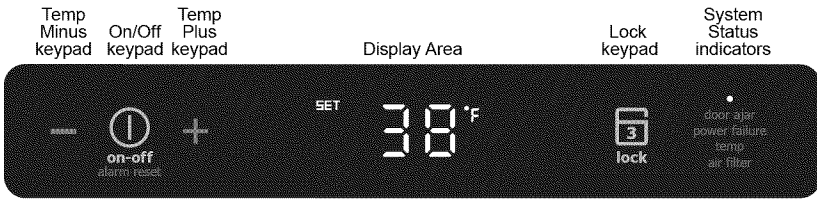

Electronic Control Display



Starting your appliance:

Plug the appliance power cord into a 115 volt wall outlet. Your appliance is shipped from the factory in the "On" position and will begin start-up of cooling as soon as power is supplied. If the appliance does not start, confirm that the wall outlet has power, and that the control is in the "On" position, (See "Turning your appliance On and Off" below).

The control display is covered with a clear plastic film. This film may be removed by carefully lifting the film at a corner.

On initial power up, the control display will indicate a "Power Failure" alarm. This is a normal condition as the appliance was powered-up at the factory for quality inspection and then removed from power. A momentary press of the "On/Off" keypad will reset this alarm condition. (See Alarms section).

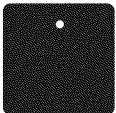

Sleep mode:

If no keypads are pressed for 60 seconds, the display will enter sleep mode to conserve power. The control panel will go dark with the exception of the system status "OK" indicator which will remain enabled. Alarm conditions will wake the display, (See Alarms section).

To make the following changes to the control settings (turning the appliance ON/OFF, adjusting the temperature, changing the interior lights, and activating vacation mode), the control must be awake.

To wake the display press any keypad. A confirm tone will sound, and the current storage compartment temperature will be displayed.

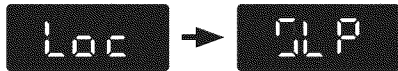
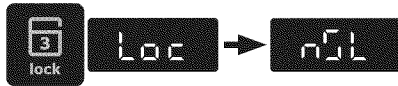

The sleep mode can be disabled if you prefer to have the display on continuously. Press and hold the "Lock" keypad until the display goes past "Loc" and reads "nSL". To enable the sleep mode, repeat the instruction, again going past "Loc" until the display reads "SLP".



Turning your appliance ON and OFF:

If the appliance is "On", (and out of sleep mode) the temperature will be shown in the display area of the control. To turn the appliance "Off", press and hold the "On/Off" keypad for four seconds. "OFF" will now be displayed on the control.



To turn the appliance "On", press and hold the "On/Off" keypad for four seconds.

10 Operation



Adjusting the temperature:

To set or check the set-point temperature (with the control out of sleep mode), press the "-" or "+" keypads. "SET" will be indicated on the user interface panel and the current set-point temperature will display and flash. Subsequent presses of the "-" or "+" keypads will adjust the temperature colder or warmer respectively. When you have reached your desired set-point temperature, press the "On/Off" keypad to accept, or do nothing and the "Set" mode will time-out in 10 seconds accepting the displayed temperature as the new set-point.

The available set-point temperature range for your appliance is 34°F (1.1°C) to 42°F (5.6°C). If you attempt to adjust the temperature outside of this range you will receive an audible notification.

When initially loading your product with warm contents, it may take up to 48 hours for the storage compartment temperature to stabilize.

When making temperature set-point changes, it may take up to 24 hours for the stored contents to stabilize at your new set-point temperature.

Factors that affect the storage compartment stabilized temperature:

- Changes to temperature setting.
- Room temperature changes.
- Temperature of stored contents.
 - Loading warm contents.
 - Cold content load will delay the change to a warmer set-point temperature.
 - Warm content load will delay the change to a colder set-point temperature.
- Usage, (number and duration of the drawer openings).
- Use of the storage compartment display lighting.
- Installation of the appliance in direct sunlight or next to a heat source.



Temperature mode:

The temperature mode is preset from the factory in Fahrenheit (°F) but you have the option to change it to Centigrade (°C). To change the mode, press and hold the "-" keypad, while pressing the "+" keypad, then release the "-" keypad.

The temperature will now be displayed in Centigrade (°C).

Repeat the procedure to change the temperature mode back to Fahrenheit (°F).



Control lock:

The control panel can be locked to avoid unintentional changes. To lock the control, press and hold the "Lock" keypad until the display reads "Loc". The lock icon will flash three times and then continuously illuminate. When the control panel is locked, only the Lock keypad, System Status OK indicator, and the Alarm indicator are active. To unlock the control panel, repeat this instruction until the display reads "nLc".

Alarms

The control will alert you to conditions that could adversely affect the performance of the appliance.



Door ajar - If the drawer is open, or not closed properly, for more than five minutes the System Status OK indicator will turn-off, the "Door Ajar" indicator will flash, and a tone will sound every 60 seconds. Additionally, an "ALARM RESET" indicator will be displayed below the "On/Off" keypad. This alarm condition can be reset by closing the drawer or momentarily pressing the "On/Off" keypad, (i.e. if you are cleaning the storage compartment, etc.). The alarm will recur in five minutes if the alarm condition persists.



Power failure - If power to the appliance is interrupted the System Status indicator will turn-off and the "Power Failure" indicator will flash. Additionally, an "ALARM RESET" indicator will be displayed below the "On/Off" keypad. No audible tone will sound. This alarm condition can be reset by momentarily pressing the "On/Off" keypad. If this alarm occurs, it is recommended that you check the condition of any perishables, even if the appliance is operating normally and the temperature has recovered. Prolonged power outages could result in excessive temperature excursions which may spoil perishables.

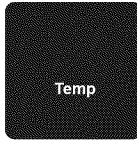

Temperature alarm - If the storage compartment temperature exceeds 10°F from set-point for more than a one hour duration, the System Status indicator will turn off, the "Temp" indicator will flash, and an audible tone will sound every 60 seconds. Additionally, an "ALARM RESET" indicator will be displayed below the "On/Off" keypad. This alarm condition can be reset by momentarily pressing the "On/Off" keypad. If this alarm occurs, it is recommended that you check the condition of your stored contents. Even though the appliance is operating normally and the temperature has recovered, prolonged temperature excursions could spoil perishables.



NOTE

Multiple alarms are possible. For instance, "Door Ajar" alarming for a prolonged period may trigger a "Temp" alarm, in which case both "Door Ajar" and "Temp" indicators will activate.



NOTE

The system status "OK" indicator (blue dot at top of alarm window) will remain lit whenever the unit is operating properly.

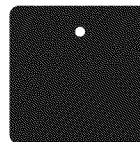

12 Operation



Air Filter - The control will notify you as to when it is time to replace the air filter (every six months). The System Status indicator will turn off and the "Air Filter" indicator will flash. Additionally an "ALARM RESET" indicator will be displayed below the "ON/OFF" keypad. No audible tone will sound. The air filter condition can be reset by momentarily pressing the "ON/OFF" keypad and the alarm will then display after another six months.

Vacation/Sabbath mode:

This operating mode can be used to save energy during high cost energy periods, or when you won't be using your appliance for an extended period of time. Vacation mode also serves as a Sabbath mode, disabling functions and its controls in accordance with the weekly Sabbath and religious holidays observed within the Orthodox Jewish community. When used as Sabbath mode, you may open or close the door at any time to access contents without concern of directly turning on or off any lights, digital readouts, solenoids, fans, valves, compressor, icons, tones, or alarms.



When activated, the display, alarm indicators and tones, keypad touch tones, interior lights, and all options are disabled. All keypad functions are disabled, with the exception of the "On/Off" keypad which is required to exit Vacation/Sabbath mode. Storage compartment temperatures are monitored and controlled at the settings prior to entering Vacation/Sabbath mode. For further assistance, guidelines for proper usage and a complete list of models with the Sabbath feature, please visit the web at <http://www.star-k.org>.

Sabbath feature, please visit the web at <http://www.star-k.org>.

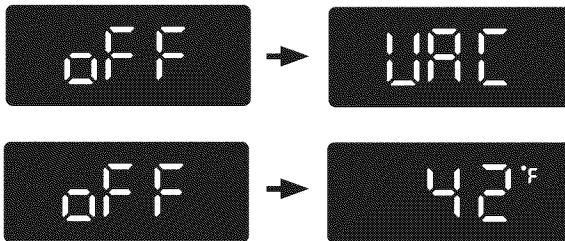

To enter Vacation/Sabbath Mode (with the control out of sleep mode), press and hold the "On/Off" keypad until the display goes past "OFF" and reads "VAC". The display will flash "VAC" three times to acknowledge your request, then will display "VAC" continuously until Vacation/Sabbath mode is exited. A power outage will not exit Vacation/Sabbath mode, exiting can only be accomplished manually. To exit Vacation/Sabbath mode and return to normal operation, press and hold the "On/Off" keypad until the control displays the temperature.



WARNING

ELECTROCUTION HAZARD

- Never attempt to repair or perform maintenance on the appliance until the main electrical power has been disconnected. Turning the appliance control "OFF" does not remove electrical power from the units wiring.
- Replace all parts and panels before operating.

Remove Drawers from unit

Begin by pulling out the top drawer. (See Figure 9). Remove screws securing drawer to slides (See Figure 10). Pull drawer forward, lift up and out to clear clips in rear of drawer. Move drawer forward about 1" (2.5 cm) and set down on slides. Repeat for bottom drawer but disregard the harness instructions as there is no wiring to the bottom drawer.

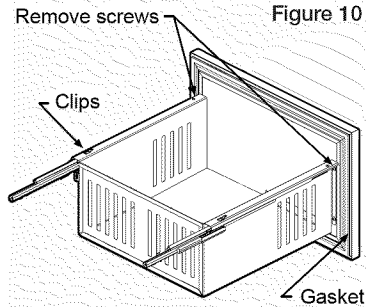

Figure 10

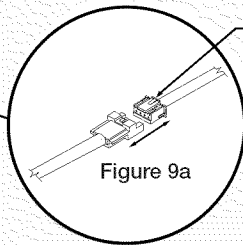
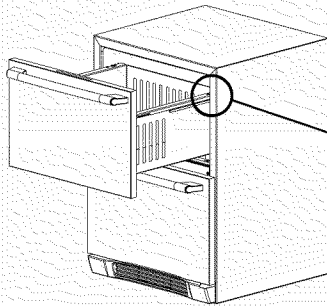

Figure 9a

Press and hold down this tab on the wire connector and pull the connector apart.

Figure 9

To replace the air filter:

Fully extend the bottom drawer. The air filter is located on the left lower wall of the cabinet. Remove the old air filter and replace with a new air filter. See Figure 11.

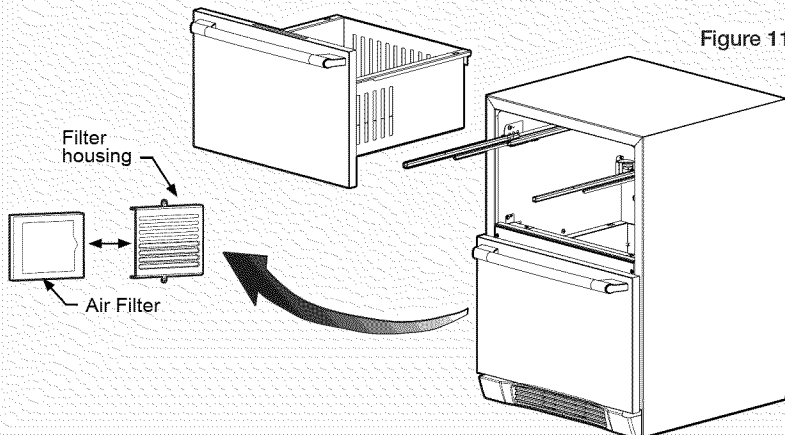

Figure 11

Bottom drawer divider

The bottom drawer has a divider that can be flipped up or down depending on your preference. There are three positions for the divider.

UP- Use to create a partition between the front and rear of the drawer.

FLAT- Use to extend the rear of the drawer bottom.

DOWN- Use to combine the front and rear areas of the drawer.

Move the spring loaded outside latches toward the center of the drawer and release into a new position.

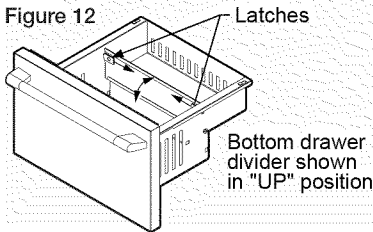

Care and cleaning

Front Grille

Be sure that nothing obstructs the required air flow openings in front of the cabinet. At least once or twice a year, brush or vacuum lint and dirt from the front grille area.

Cabinet

The painted cabinet can be washed with either a mild soap and water and thoroughly rinsed with clear water. NEVER use abrasive scouring cleaners.

Interior

Wash interior compartment with mild soap and water. Do NOT use an abrasive cleaner, solvent, polish cleaner or undiluted detergent.

Care of Appliance

1. Avoid leaning on the drawer, you may bend the drawer slides or tip the appliance.
2. Exercise caution when sweeping, vacuuming or mopping near the front of the appliance. Damage to the grille can occur.
3. Periodically clean the interior of the appliance as needed.
4. Periodically check and/or clean the front grille as needed.

In the Event of a Power Failure

If a power failure occurs, try to correct it as soon as possible. Minimize the number of drawer openings while the power is off so as not to adversely affect the appliance's temperature.

Light assembly replacement

All models use an LED to illuminate the interior of the appliance. This component is very reliable, but should it fail, contact a qualified service technician for replacement of the LED.

The following suggestions will minimize the cost of operating your refrigeration appliance.

1. Do not install your appliance next to a hot appliance (cooker, dishwasher, etc.), heating air duct, or other heat sources.
2. Install product out of direct sunlight.
3. Ensure the front grille vents at front of appliance beneath drawer are not obstructed and kept clean to allow ventilation for the refrigeration system to expel heat.
4. Plug your appliance into a dedicated power circuit. (Not shared with other appliances).
5. When initially loading your new product, or whenever large quantities of warm contents are placed within refrigerated storage compartment, minimize drawer openings for the next 12 hours to allow contents to pull down to compartment set temperature.
6. Maintaining a relatively full storage compartment will require less appliance run time than an empty compartment.
7. Ensure drawer closing is not obstructed by contents stored in your appliance.
8. Allow hot items to reach room temperature before placing in product.
9. Minimize drawer openings and duration of drawer openings.
10. Use the warmest temperature control set temperature that meets your personal preference and provides the proper storage for your stored contents.
11. When on vacation or away from home for extended periods, set the appliance to warmest acceptable temperature for the stored contents.
12. Set the control to the "off" position if cleaning the appliance requires the drawer to be open for an extended period of time.

Maintaining Your Refrigerated Drawers

Periodic cleaning and proper maintenance will ensure efficiency, top performance, and long life. The maintenance intervals listed are based on normal conditions. You may want to shorten the intervals if you have pets or other special considerations.

Exterior Cleaning for Your Stainless Steel Model

- Your stainless steel model may discolor when exposed to chlorine gas, pool chemicals, salt water, or cleaners with bleach.
- Keep your stainless unit looking new by cleaning with a high quality, all-in-one stainless steel cleaner/polish on a monthly basis. Frequent cleaning will remove surface contamination that could lead to rust. Some installations will require cleaning on a weekly basis.
- DO NOT CLEAN WITH STEEL WOOL PADS.
- DO NOT USE CLEANERS THAT ARE NOT SPECIFICALLY INTENDED FOR STAINLESS STEEL (this includes glass, tile and counter cleansers).
- If any surface discolors or rusting appears, clean it quickly with Bon-Ami or Barkeepers Friend Cleanser and a non-abrasive cloth. Always clean in the direction of the grain. Always finish this process with a high quality, all-in-one stainless steel cleaner/polish to prevent further problems.
- USE OF ABRASIVE PADS SUCH AS SCOTCHBRITE WILL CAUSE THE GRAINING IN THE STAINLESS TO BECOME BLURRED.
- Rust that is allowed to linger can penetrate into the surface of the stainless steel and become impossible to remove.



CAUTION

- Stainless steel models exposed to chlorine gas and moisture such as areas with spas or swimming pools, may have some discoloration of the stainless steel. Discoloration from chlorine gas is normal. Follow exterior cleaning instructions.
- NEVER USE CHLORIDE OR CLEANERS CONTAINING BLEACH TO CLEAN STAINLESS STEEL.

Interior Cleaning - as Required

- 1 Disconnect power to the Refrigerated Drawers.
- 2 Remove racks if desired, see "WINE RACK REMOVAL/INSTALLATION" below.
- 3 Wipe down the interior with a solution of non-abrasive mild detergent and warm water.
- 4 Rinse with clear water.
- 5 Reconnect power to the unit.

Air Filter

Install the static air filter, located in the literature pack, in the proper housing.

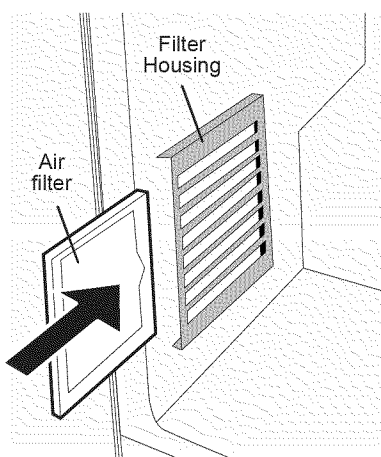

Ordering replacement filters

Order new filters by calling toll-free 1-877-808-4195, visiting www.electroluxappliances.com, or seeing the dealer where you bought your Refrigerated Drawers. Electrolux recommends that you order extra filters when you first install your Refrigerated Drawers, and that you replace your filters at least once every six months.

Here is the product number to request when ordering:

PureAdvantage™ Air Filter,
Part # **EAFCBF**

16 Maintenance

Removing and installing the grille:

Open the drawer, squeeze the grille (top and bottom) which will release the tabs on the grille and pull it toward you to remove from the cabinet. Reverse the procedure for installing the grille.

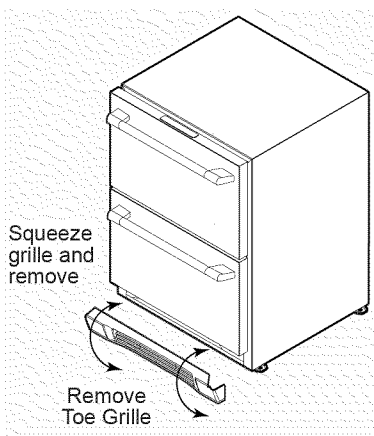

Service data sheet location:

The service data sheet is included in a clear pouch taped to the back of the cabinet.

If Service is Required:

- If the product is within the first year warranty period please contact your dealer or call Electrolux Customer Service at 877.435.3287 for directions on how to obtain warranty coverage in your area.
- If the product is outside the first year warranty period, Electrolux Customer Service can provide recommendations of service centers in your area.
- In all correspondence regarding service, be sure to give the model number, serial number, and proof of purchase.
- Try to have information or description of nature of the problem, how long the appliance has been running, the room temperature, and any additional information that may be helpful in quickly solving the problem.

Before You Call for Service If Service is Required

If the unit appears to be malfunctioning, read through this manual first. If the problem persists, check the **Troubleshooting Guide** below. Locate the problem in the guide and refer to the cause and its remedy before calling for service. The problem may be something very simple that can be solved without a service call. Consulting or contracting a qualified service technician may be necessary.

Contact the dealer where you purchased the unit if service is required. State the model and serial number and explain the problem. The model and serial number plate is located on the ceiling of your unit. If you do not know the name of the selling dealer or a local service company, you can check online at www.electroluxappliances.com or call **1-877-435-3287**.



WARNING

ELECTROCUTION HAZARD

NEVER attempt to repair or perform maintenance on the unit until the main electrical power has been disconnected.

Problem	Possible Cause	Remedy
Unit not cold enough. Adjust temperatures (see "Adjusting the Temperature" in the "Start-Up and Temperature Control" section).	<ul style="list-style-type: none"> Control set too warm. Light staying on. Airflow to front grille blocked. Drawer gasket not sealing properly. 	<ul style="list-style-type: none"> Adjust temperature colder. Allow 24 hours for temperature to stabilize. Turn off manual light control. See "Operation" section. Airflow must not be obstructed to front grille. See "Installation" section. Adjust drawer gasket.
Unit too cold. Contents of unit too cold/frozen. Adjust temperatures (see "Adjusting the Temperature" in the "Start-Up and Temperature Control" section).	<ul style="list-style-type: none"> Control set too cold. Drawer gasket not sealing properly. 	<ul style="list-style-type: none"> Adjust temperature warmer. Allow 24 hours for temperature to stabilize.
No interior light.	<ul style="list-style-type: none"> Failed LED assembly. 	<ul style="list-style-type: none"> Contact a qualified Electrolux Service Technician.
Light will not go out when drawer is closed.	<ul style="list-style-type: none"> Manual light control is ON. Drawer switch not making contact. 	<ul style="list-style-type: none"> Turn off manual light control. See "Operation" section. Check for proper drawer alignment.
Alarm(s) will not shut off.	<ul style="list-style-type: none"> Drawer is ajar. Power has failed. Internal temperature is too high. 	<ul style="list-style-type: none"> Press "Power" key to acknowledge alarm. Ensure drawer is closed firmly. Allow 24 hours for temperature to stabilize.
Power is not restored after power failure.	<ul style="list-style-type: none"> Circuit breaker has tripped. 	<ul style="list-style-type: none"> Verify electrical supply. See "Installation" section.

18 Warranty Information

Major Appliance Warranty Information

Your appliance is covered by a one year limited warranty. For one year from your original date of purchase, Electrolux will repair or replace any parts of this appliance that prove to be defective in materials or workmanship when such appliance is installed, used, and maintained in accordance with the provided instructions. In addition, the cabinet liner and sealed refrigeration system (compressor, condenser, evaporator, dryer or tubing) of your appliance is covered by a two through five year limited warranty. During the 2nd through 5th years from your original date of purchase, Electrolux will repair or replace any parts in the cabinet liner and sealed refrigeration system which prove to be defective in materials or workmanship when such appliance is installed, used, and maintained in accordance with the provided instructions.

Exclusions

This warranty does not cover the following:

1. Products with original serial numbers that have been removed, altered or cannot be readily determined.
2. Product that has been transferred from its original owner to another party or removed outside the USA or Canada.
3. Rust on the interior or exterior of the unit.
4. Products purchased "as-is" are not covered by this warranty.
5. Food loss due to any refrigerator or freezer failures.
6. Products used in a commercial setting.
7. Service calls which do not involve malfunction or defects in materials or workmanship, or for appliances not in ordinary household use or used other than in accordance with the provided instructions.
8. Service calls to correct the installation of your appliance or to instruct you how to use your appliance.
9. Expenses for making the appliance accessible for servicing, such as removal of trim, cupboards, shelves, etc., which are not a part of the appliance when it is shipped from the factory.
10. Service calls to repair or replace appliance light bulbs, air filters, water filters, other consumables, or knobs, handles, or other cosmetic parts.
11. Pickup and delivery costs; your appliance is designed to be repaired in the home.
12. Surcharges including, but not limited to, any after hour, weekend, or holiday service calls, tolls, ferry trip charges, or mileage expense for service calls to remote areas, including the state of Alaska.
13. Damages to the finish of appliance or home incurred during transportation or installation, including but not limited to floors, cabinets, walls, etc.
14. Damages caused by: services performed by unauthorized service companies; use of parts other than genuine Electrolux parts or parts obtained from persons other than authorized service companies; or external causes such as abuse, misuse, inadequate power supply, accidents, fires, or acts of God.

DISCLAIMER OF IMPLIED WARRANTIES; LIMITATION OF REMEDIES

CUSTOMER'S SOLE AND EXCLUSIVE REMEDY UNDER THIS LIMITED WARRANTY SHALL BE REPAIR OR REPLACEMENT AS PROVIDED HEREIN. CLAIMS BASED ON IMPLIED WARRANTIES, INCLUDING WARRANTIES OF MERCHANTABILITY OR FITNESS FOR A PARTICULAR PURPOSE, ARE LIMITED TO ONE YEAR OR THE SHORTEST PERIOD ALLOWED BY LAW, BUT NOT LESS THAN ONE YEAR. ELECTROLUX SHALL NOT BE LIABLE FOR CONSEQUENTIAL OR INCIDENTAL DAMAGES SUCH AS PROPERTY DAMAGE AND INCIDENTAL EXPENSES RESULTING FROM ANY BREACH OF THIS WRITTEN LIMITED WARRANTY OR ANY IMPLIED WARRANTY. SOME STATES AND PROVINCES DO NOT ALLOW THE EXCLUSION OR LIMITATION OF INCIDENTAL OR CONSEQUENTIAL DAMAGES, OR LIMITATIONS ON THE DURATION OF IMPLIED WARRANTIES, SO THESE LIMITATIONS OR EXCLUSIONS MAY NOT APPLY TO YOU. THIS WRITTEN WARRANTY GIVES YOU SPECIFIC LEGAL RIGHTS. YOU MAY ALSO HAVE OTHER RIGHTS THAT VARY FROM STATE TO STATE.

If You Need Service

Keep your receipt, delivery slip, or some other appropriate payment record to establish the warranty period should service be required. If service is performed, it is in your best interest to obtain and keep all receipts. Service under this warranty must be obtained by contacting Electrolux at the addresses or phone numbers below.

This warranty only applies in the USA, Puerto Rico and Canada. In the USA and Puerto Rico, your appliance is warranted by Electrolux Major Appliances North America, a division of Electrolux Home Products, Inc. In Canada, your appliance is warranted by Electrolux Canada Corp. Electrolux authorizes no person to change or add to any obligations under this warranty. Obligations for service and parts under this warranty must be performed by Electrolux or an authorized service company. Product features or specifications as described or illustrated are subject to change without notice.

USA
1-877-435-3287
Electrolux Major Appliances North America
10200 David Taylor Drive
Charlotte, NC 28262

Canada
1-800-265-8352
Electrolux Canada Corp.
5855 Terry Fox Way
Mississauga, Ontario,
Canada L5V 3E4