

SU12F40 SERIES

# Vacuum Cleaner user manual

- ※ Please read the User Manual thoroughly before operating the vacuum.
- ※ For indoor use only.

English

imagine the possibilities

Thank you for purchasing a Samsung product.  
To receive a more complete service,  
please register your product at  
[www.samsung.com/register](http://www.samsung.com/register)

**SAMSUNG**

# Contents

---

## **YOUR VACUUM CLEANER**

- 06 Product view
- 07 Carton contents

06

## **BEFORE USING THE VACUUM CLEANER**

- 08 Assemble the handle and pipe
- 09 Attaching the accessories
- 10 Using the accessories

08

## **OPERATING THE VACUUM**

- 11 Stowing the power cord
- 12 Extending the Pipe
- 12 Using upright mode
- 13 Operating the Brush bar On / Off Switch
- 13 Resetting the overload protector
- 13 Using the vacuum's handle (The dust bin handle)
- 14 Using the accessory kit (optional)

11

## **MAINTENANCE**

- 16 Emptying the dust bin
- 17 Cleaning the grille
- 18 Cleaning the premotor filter
- 20 Cleaning the hepa filter
- 22 Checking Brush
- 23 Checking for clogs
- 24 Mini turbo brush (optional)
- 25 Cleaning the diverter cover

16

## **TROUBLESHOOTING**

26

# Safety information

---

## SAFETY INFORMATION

---



Before operating the appliance, please read this manual thoroughly and retain it for your reference.



Because the following operating instructions cover various models, the characteristics of your vacuum cleaner may differ slightly from those described in this manual.

## CAUTION/WARNING SYMBOLS USED

	Indicates that a risk of death or serious injury exists.
	Indicates that a risk of personal injury or material damage exists.

## OTHER SYMBOLS USED

	Indicates something you must NOT do.
	Indicates instructions you must follow.
	Indicates that you must disconnect the power plug from the socket.



This vacuum cleaner is designed for household use only.

Do not use this vacuum cleaner to clean building waste or debris.

Clean the filters regularly to prevent fine dust from collecting in them.

Do not use this vacuum cleaner with any of the filters removed.

**Failure to meet these requirements could cause injury, damage the vacuum cleaner and void your warranty.**

## **IMPORTANT SAFETY INSTRUCTIONS**

---

When using an electrical appliance, you should always follow these basic precautions:

### **READ ALL INSTRUCTIONS BEFORE USING YOUR UPRIGHT VACCUUM**

### **WARNING – TO REDUCE THE RISK OF FIRE, ELECTRIC SHOCK, OR INJURY:**

1. Do not leave the vacuum cleaner unattended when it is plugged in. Unplug it from the outlet when you are not using it and before servicing.
2. Do not use outdoors or on wet surfaces.
3. Do not allow the vacuum to be used as a toy. Pay close attention when the vacuum is used by or near children.
4. Use only as described in this manual. Use only the manufacturer's recommended attachments.
5. Do not use with a damaged cord or plug. If the vacuum is not working as it should, has been dropped, damaged, left outdoors, or dropped into water, bring it to a service center.
6. Do not pull or carry the vacuum by the cord, use the cord as a handle, close a door on the cord, or pull the cord around sharp edges or corners. Do not run the vacuum over the cord. Keep the cord away from heated surfaces.
7. Do not unplug by pulling on the cord. To unplug, grasp the plug, not the cord.
8. Do not handle the plug or vacuum with wet hands.
9. Do not put any object into openings or vents. Do not use with any opening blocked. Keep free of dust, lint, hair, and anything that may reduce air flow.
10. Keep hair, loose clothing, fingers, and all parts of your body away from openings and moving parts.
11. Turn off all controls before unplugging.
12. Use extra care when cleaning on stairs.
13. Do not use to pick up flammable or combustible liquids, such as gasoline, or use in areas where they may be present.
14. Do not pick up anything that is burning or smoking, such as cigarettes, matches, or hot ashes.
15. Do not use without the dirt cup and/or filters in place.
16. Do not use the vacuum cleaner in an enclosed space filled with vapors given off by oil base paint, paint thinner, some moth proofing substances, flammable dust, or other explosive or toxic materials.
17. Store your vacuum cleaner indoors, in a cool and dry area.

18. Use only on dry, indoor surfaces.
19. Do not modify the polarized plug to fit a non-polarized outlet or extension cord.
20. Do not touch the brush drum when it is rotating.
21. Keep suction away from your face when using nozzles and pipe.
22. Do not pull the power cord around sharp corners and do not allow it to become trapped.
23. This vacuum is not intended for use by persons (including children) with reduced physical, sensory or mental capabilities, or lack of experience and knowledge, unless they have been given supervision or instruction concerning its use by a person responsible for their safety.
24. Children should be supervised to ensure that they do not play with the vacuum.
25. You must remove the plug from the socket-outlet before cleaning or performing maintenance on the vacuum.
26. If the power cord is damaged, it must be replaced by the manufacturer or its service agent or a similarly qualified person.
27. Hold plug when rewinding onto cord reel. Do not allow plug to whip when rewinding.
28. Do not pick up hard or sharp objects such as glass, nails, screws, coins, etc.
29. Always turn off the vacuum before connecting or disconnecting the handy vacuum cleaner.
30. Don't touch the exhaust vent when the exhaust temperature is hot.

## SAVE THESE INSTRUCTIONS

### POLARIZED PLUG INSTRUCTIONS

- To reduce the risk of electric shock, this appliance has a polarized plug (one blade is wider than the other).  
This plug will fit in a polarized outlet only one way.  
If the plug does not fit fully in the outlet, reverse the plug.  
If it still does not fit, contact a qualified electrician to install a proper outlet.  
Do not modify the plug in any way.

### State of California Proposition 65 Warning (US only)



This product contains chemicals known to the State of California to cause cancer and reproductive toxicity.

# Your vacuum cleaner

---

## PRODUCT VIEW

---

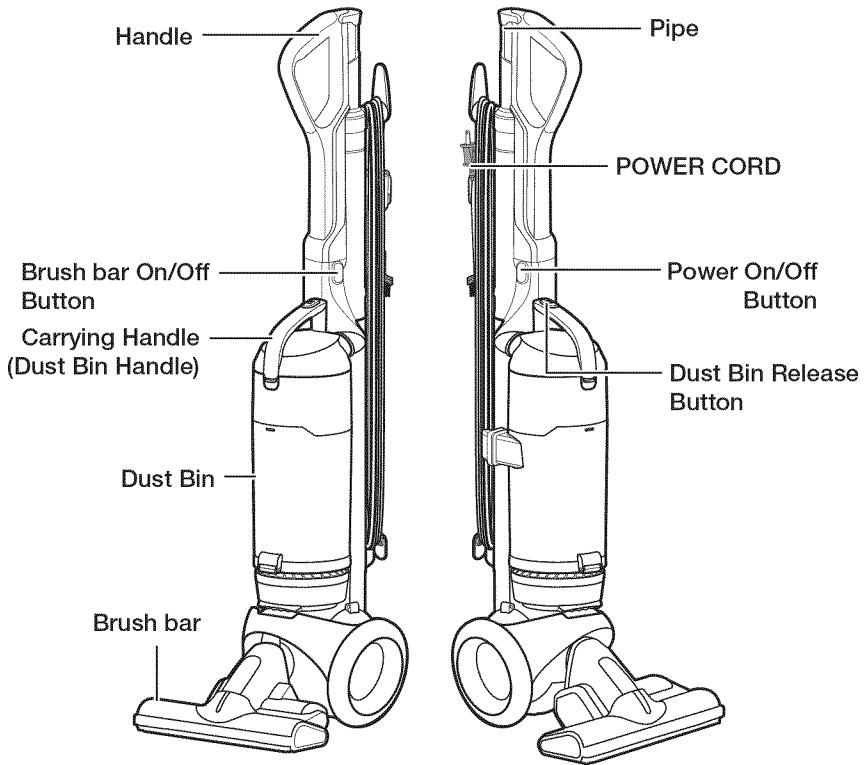

Do not plug in your vacuum cleaner until you are familiar with all instructions and operating procedures.



Plastic film can be dangerous.  
To avoid the danger of suffocation, keep the film away from babies and children.

## CARTON CONTENTS

---

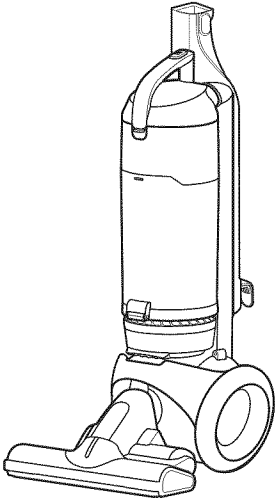

(1)

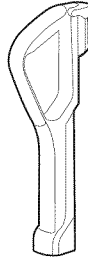

(2)

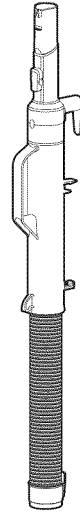

(3)



(4)

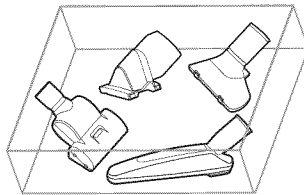

(5)



(6)

- Empty carton. Find the parts shown above before disposing of packing materials.

1. Vacuum cleaner body
2. Handle
3. Pipe
4. 2 In 1 Accessory
5. Accessory Kit (Optional depending on the model)
6. Users Manual

# Before using the vacuum cleaner

## ASSEMBLE THE HANDLE AND PIPE

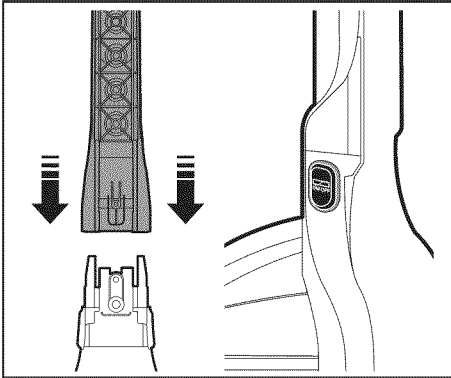

- Connect the Handle and Body.

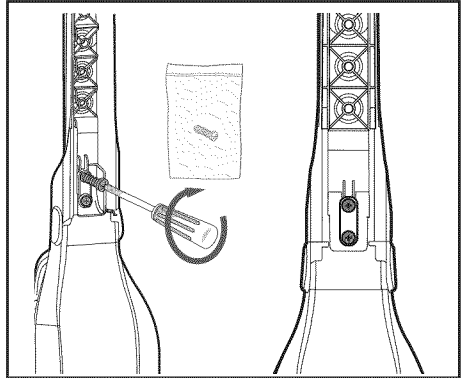

- Unpack the wrapped screw and then fasten the screw using a Phillips head (+) screwdriver as shown.

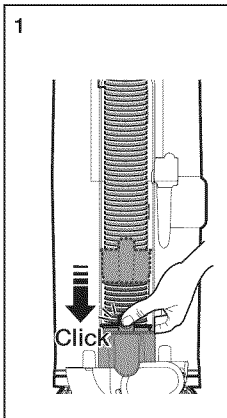

1. Stand the vacuum upright, and then insert the bottom of the pipe into the body hole until you hear a click.

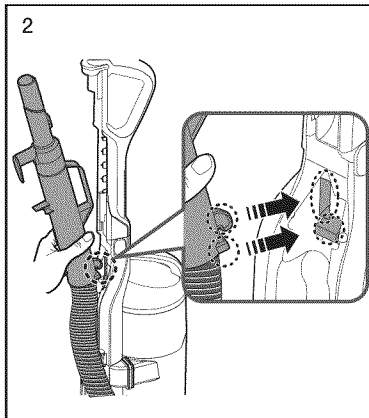

2. Insert the hook on the top portion of the pipe into the hole in the handle as shown. The hook should push the sky-blue button in the handle back.

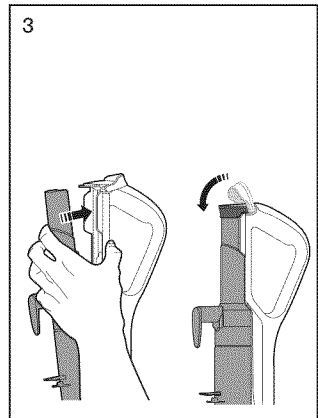

3. Attach the top of the pipe to the handle, and then cover with the cap.



- Wind cord around the cord hangers and secure with clip.

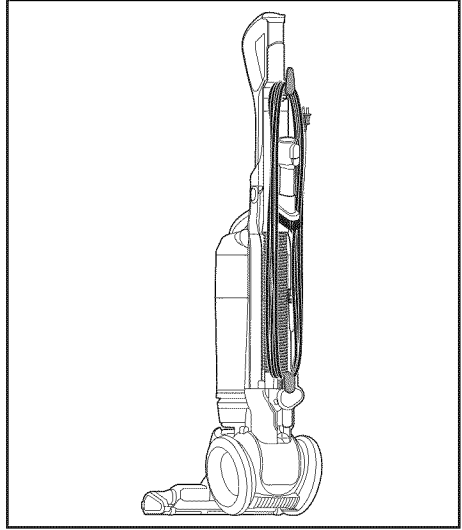

## ATTACHING THE ACCESSORIES

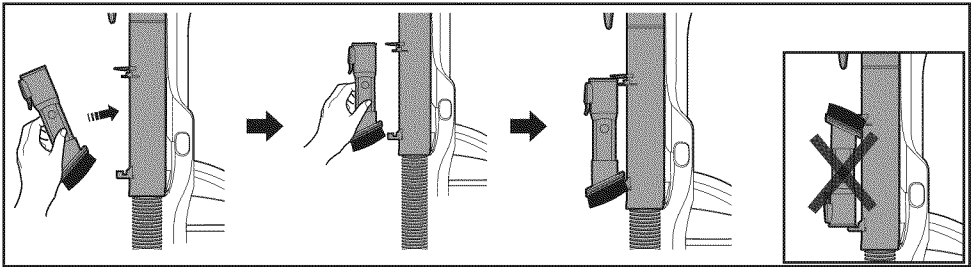

## USING THE ACCESSORIES

---

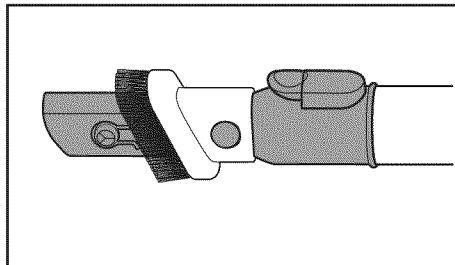
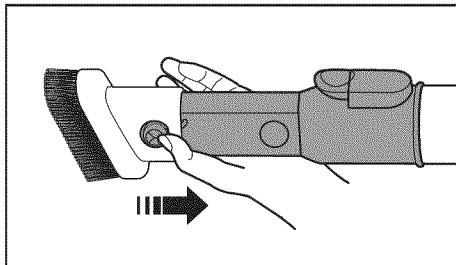

- Crevice tool

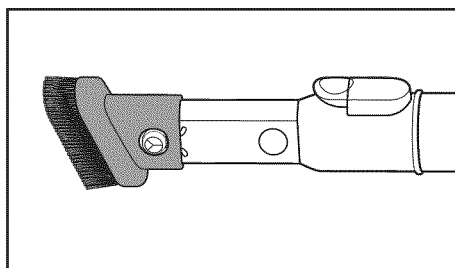
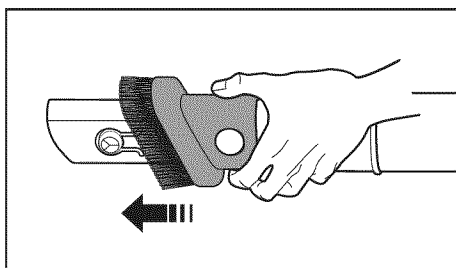

- Dusting Brush

# Operating the vacuum

## STOWING THE POWER CORD

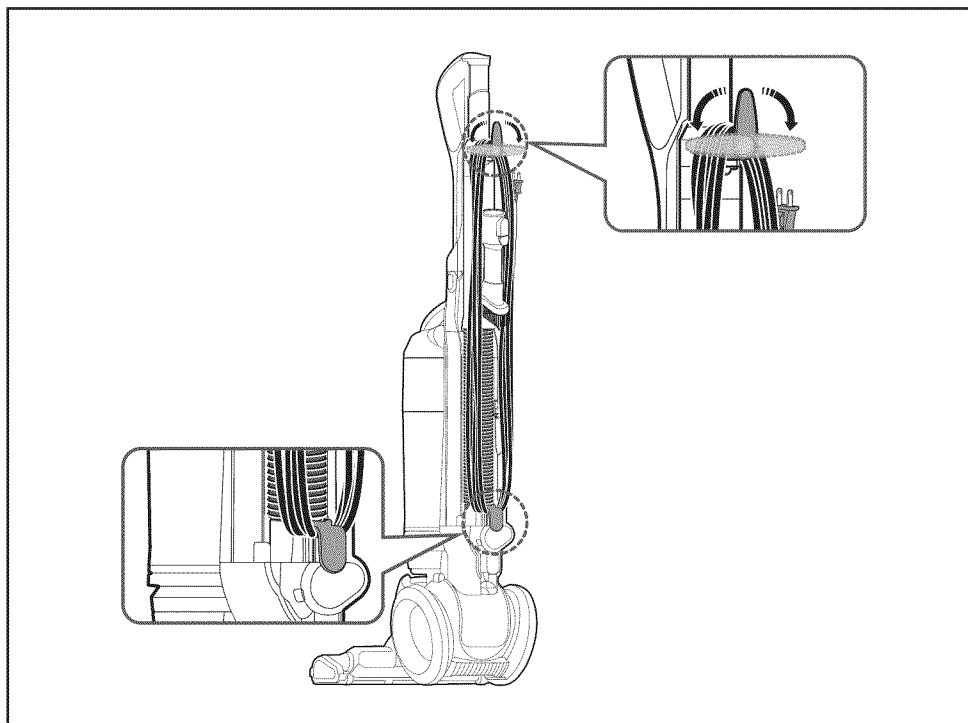

When removing the plug from an electrical outlet, grasp the plug, not the cord.

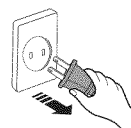

## EXTENDING THE PIPE

### Pipe mode

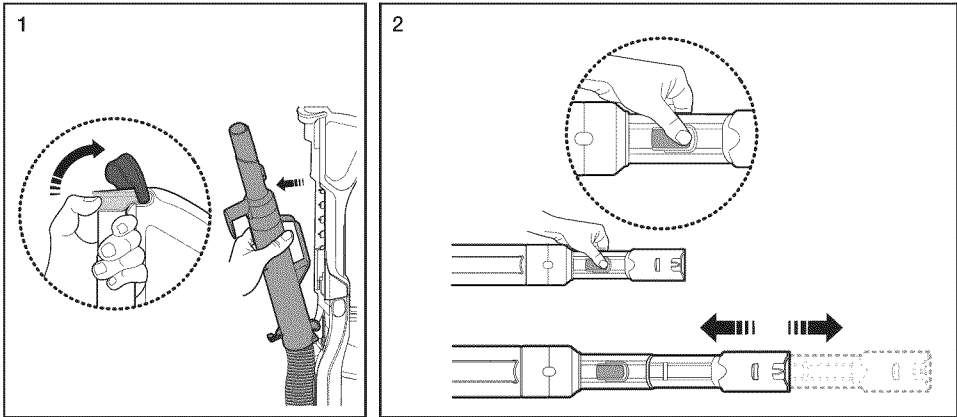

- Push up the handle cap, and then separate the pipe from the body.
- Push the button on the pipe to make the pipe longer.

## USING UPRIGHT MODE

### Upright mode

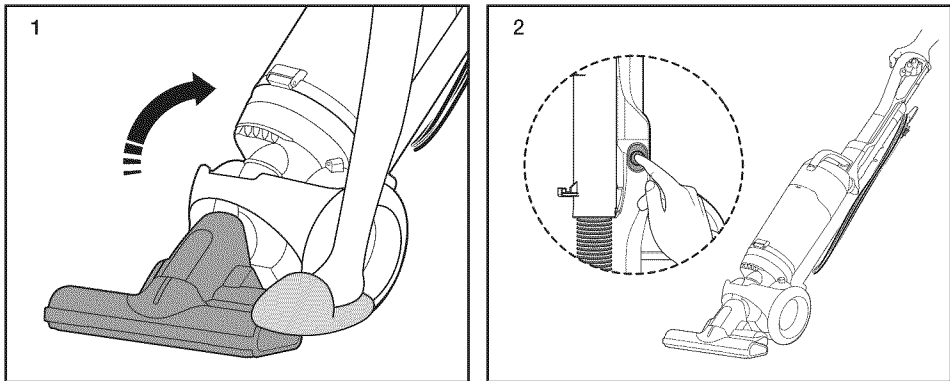

- Place a foot on the brush, and then tilt the handle back gently to release the lock.
- Push the power On/Off switch.

## OPERATING THE BRUSH BAR ON / OFF SWITCH

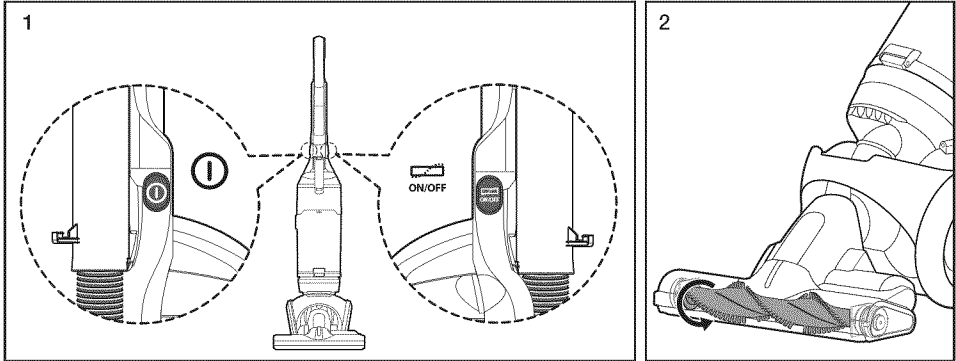

- Push the power On/Off switch, and then push the brush bar On/Off switch.



In the upright position, the Brush bar does not work.

## RESETTING THE OVERLOAD PROTECTOR

- The overload protector shuts off the brush motor if the brush bar becomes obstructed. To reset the overload protector, use a pen tip to press the reset switch.

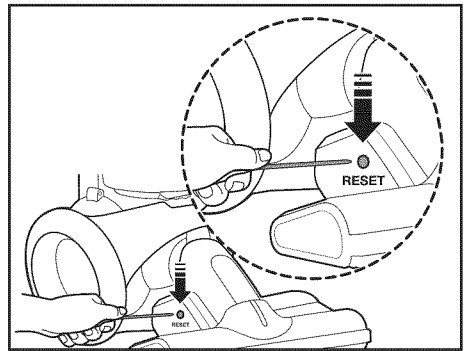

## USING THE VACUUM'S HANDLE (THE DUST BIN HANDLE)

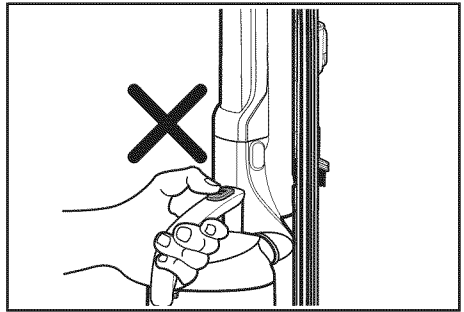
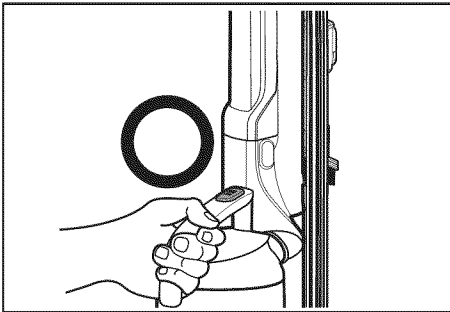

When you carry the vacuum cleaner by the handle, do not push the dust bin release button.

## USING THE ACCESSORY KIT (OPTIONAL)

---

### Furniture tool

---

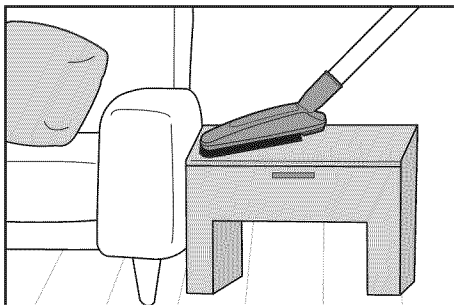
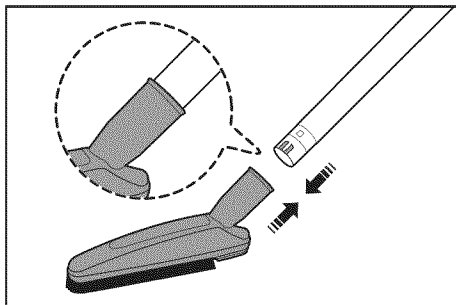

### Upholstery

---

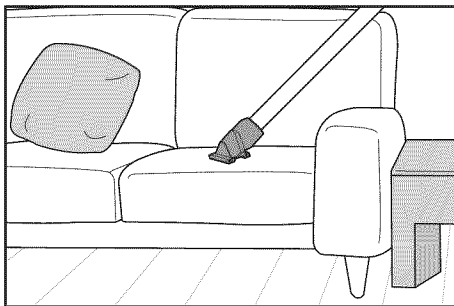
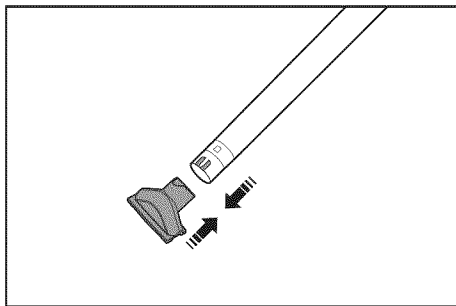

### Mini turbo brush

---

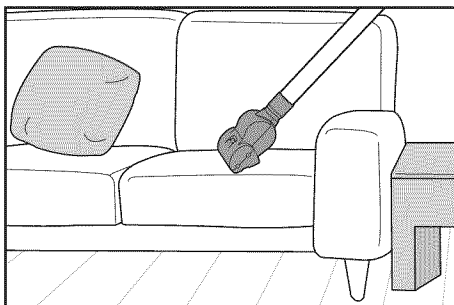
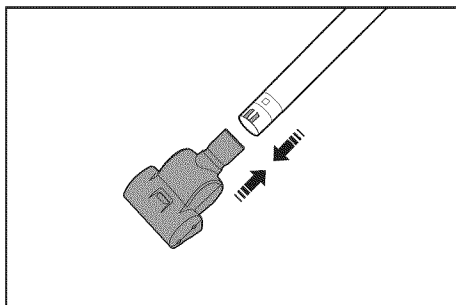

# Pet Tool

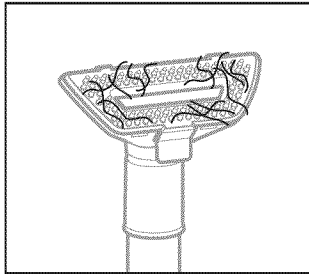
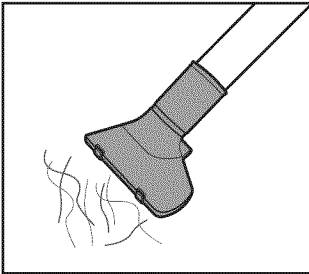
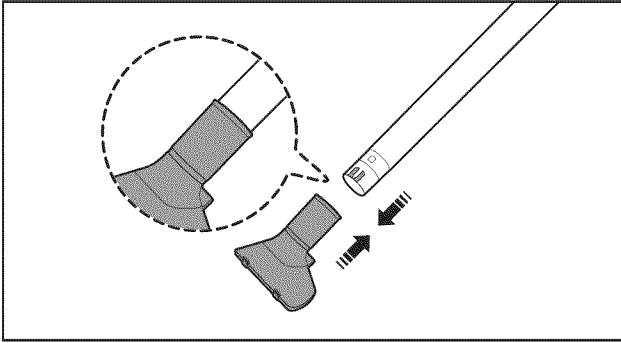

- Rake the hair.

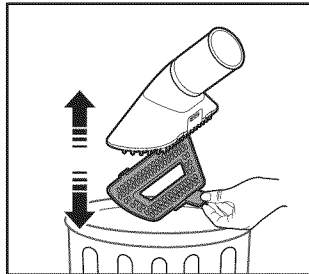
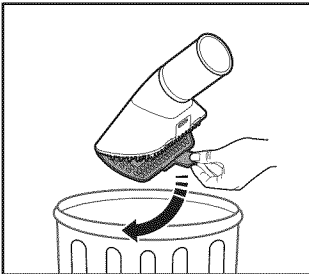

- Separate the cover from the pet tool, and then throw the hair away.

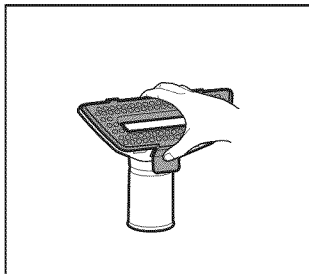
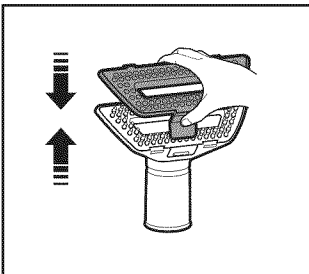

- Re-attach the cover.

# Maintenance

## EMPTYING THE DUST BIN

- Empty the dust bin when dust reaches the 'MAX' mark.
- Take the dust bin out by pushing the button on the handle.

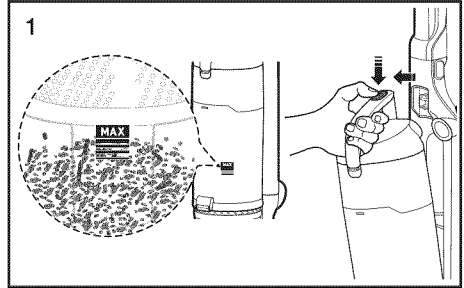

- To empty the dust bin, hold the dust bin over a garbage can, and then push the button near the bottom of the bin.

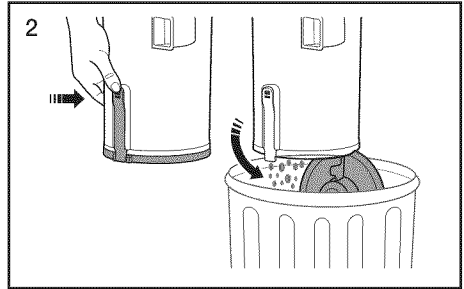

- To empty the dust bin, hold the dust bin into a plastic bag, and then push the button near the bottom of the bin. (Recommended for asthma/allergy sufferers.)

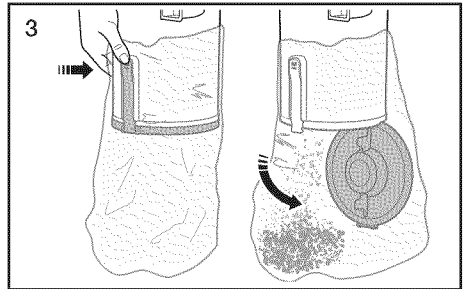

- Close the bottom of the bin, and then drop the plastic bag in the trash can. (Recommended for asthma/allergy sufferers.)

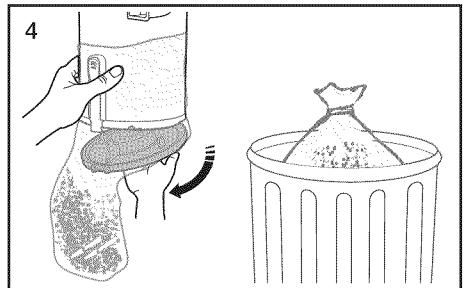



## CLEANING THE GRILLE

- Separate the dust bin from the vacuum's body.
- Clean the grille with the dusting brush to remove lint.
- To re-attach the dust bin to the vacuum's body, follow steps 3 and 4.

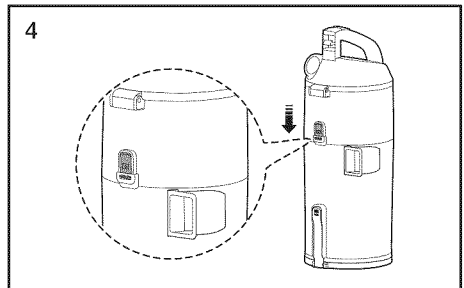
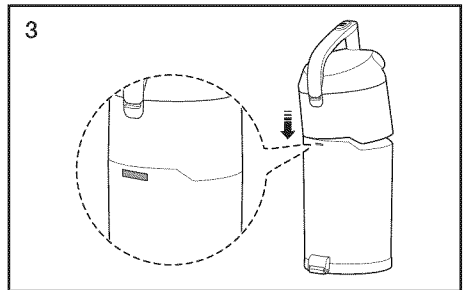
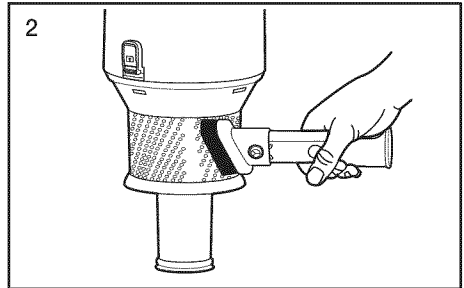
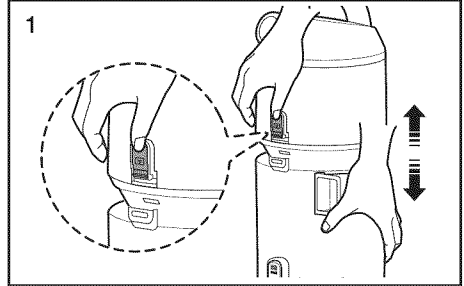

## CLEANING THE PREMOTOR FILTER



- Pull the dust bin cover to open.

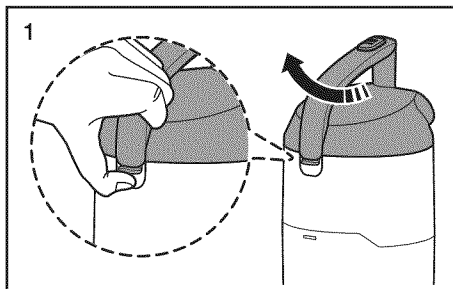

- Remove the filter from the dust bin.

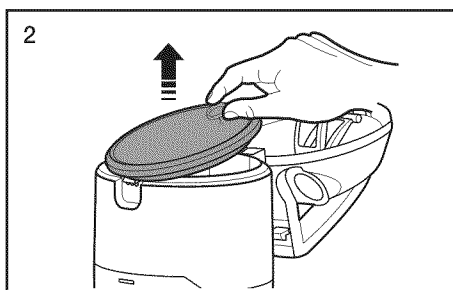

- Shake the filter to remove dust, and then wash the filter.

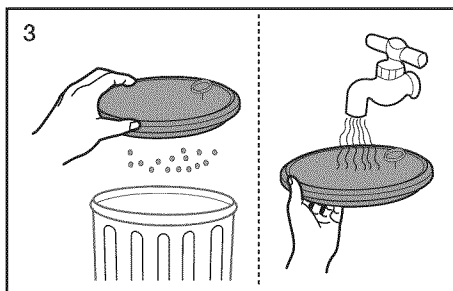

- Leave the filter in the shade until completely dry.

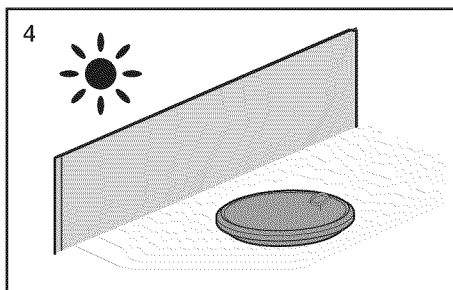

- Put the filter into the dust bin.

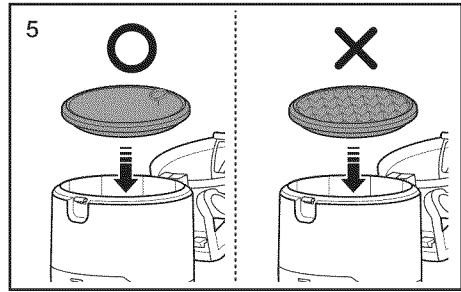

Check the filter regularly and wash every 1~2 months.  
 Make sure the filter is completely dry before putting it back into the vacuum cleaner.  
 Allow it to dry for 12 hours.  
 Do not use a wet filter  
 Replace the dust filter if it becomes damaged or deformed.  
 The dust bin cover will not close if the filter is not installed correctly.



## CLEANING THE HEPA FILTER

- Take the dust bin out by pushing the button on the handle.

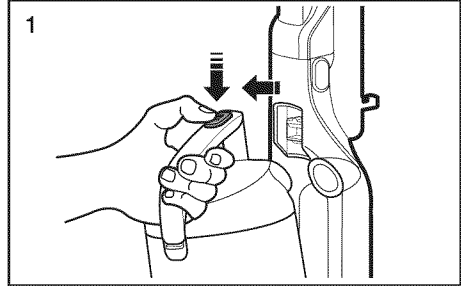

- Remove the filter cover.

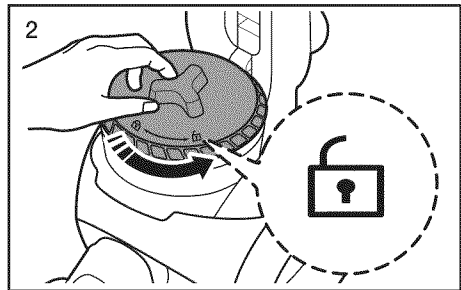

- Separate the Hepa filter from the vacuum's body.

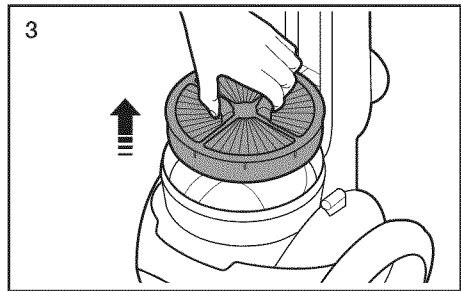

- Shake the filter to remove dust.

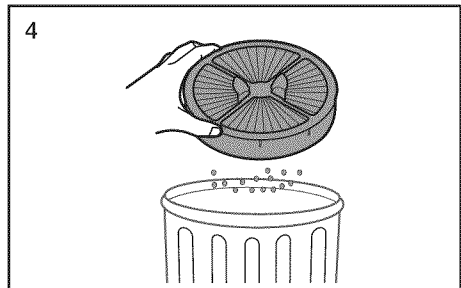

Clean the HEPA filter when suction is noticeably and continuously reduced or the vacuum cleaner overheats abnormally.

Note: HEPA Filters are not washable.

Replace the filter if cleaning does not resolve the problem.

- Re-insert the filter into the vacuum's body.

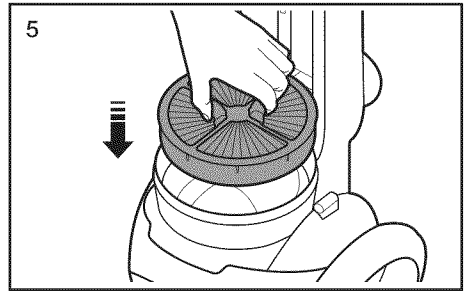

- Re-assemble the filter and filter cover.

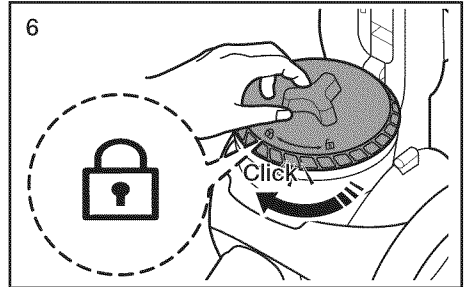

- Re-attach the dust bin to the vacuum.

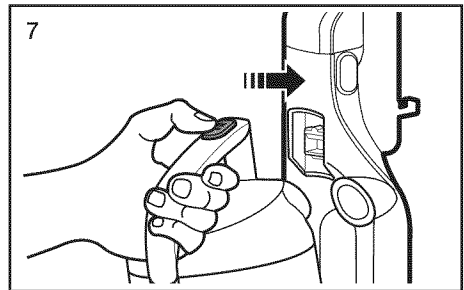

The dust bin will not re-attach to the vacuum if the filter cover is not installed correctly.

## CHECKING BRUSH

---

- Turn off and unplug the vacuum. Lie the vacuum down so its bottom is accessible as shown.

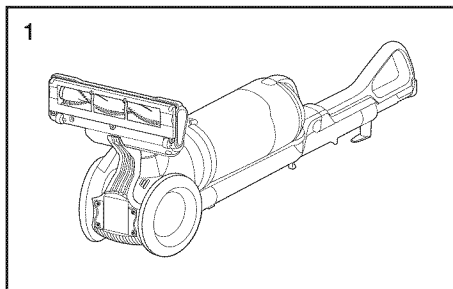

- Carefully cut off any hair or string caught in the brush.

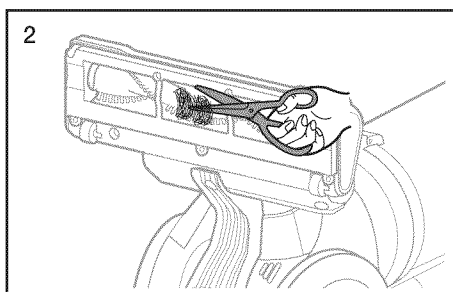

Before inspecting the brush bar, turn off the brush bar and unplug the vacuum.

## CHECKING FOR CLOGS

- Place a foot on the brush, and then tilt the handle back gently to release the lock.

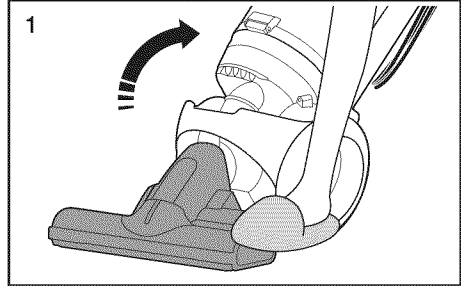

- Push the release button on the brush housing, and then pull the hose out.

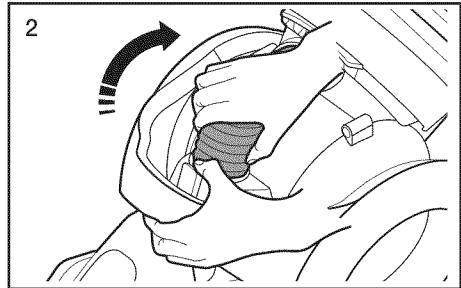

- Check for clogs in the opening of the brush housing and in the hose.

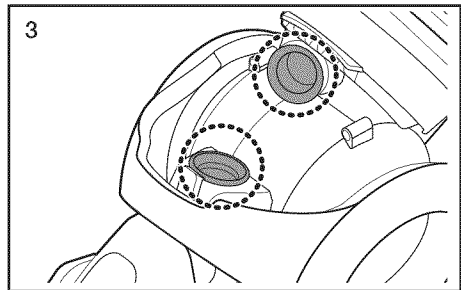

- When done, re-attach the hose to the brush housing.

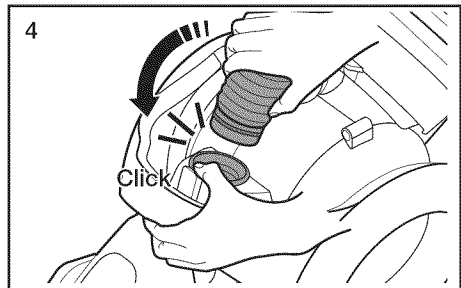

Before checking for clogs, turn off the brush bar and unplug the vacuum.

## MINI TURBO BRUSH (OPTIONAL)

### INSPECTING THE BRUSH ROLL

- If a clog is present or debris is visible, inspect the brush roll.

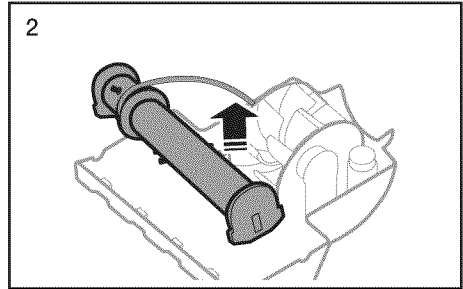
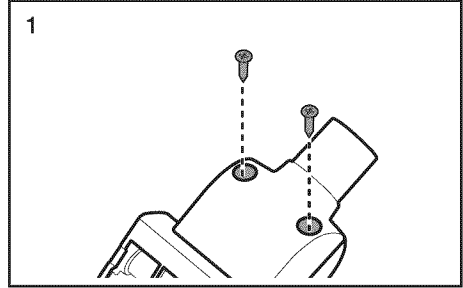

### INSPECTING THE BELT

- If the belt is broken or cracked, replace it with a new belt following the instructions on the right.

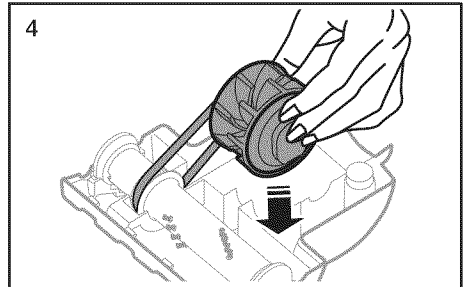
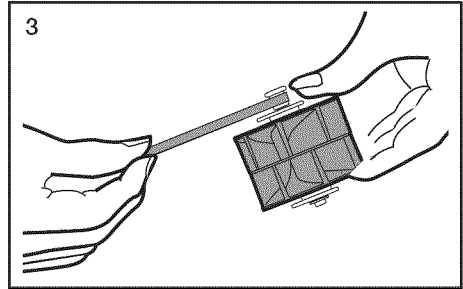



## CLEANING THE DIVERTER COVER

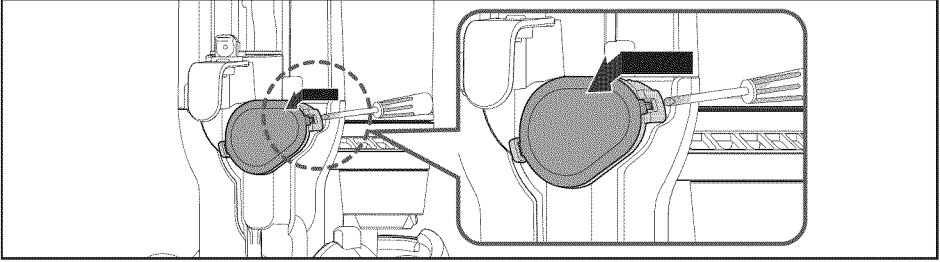

- Open the Diverter cover using a flat head (-) screwdriver.

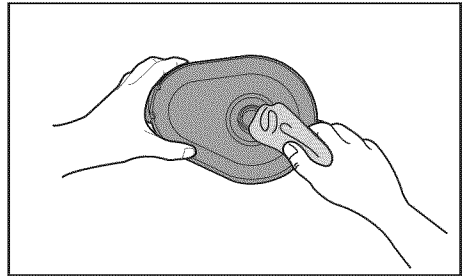
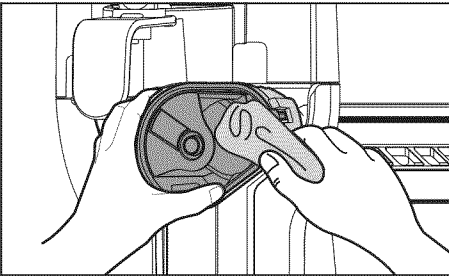

- Clean the inside of the cover with a dry cloth.

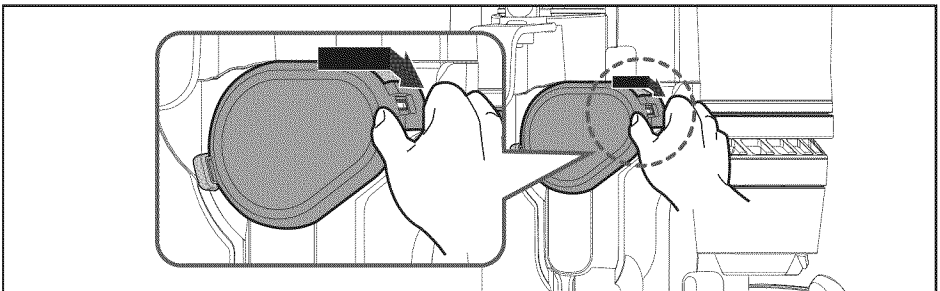
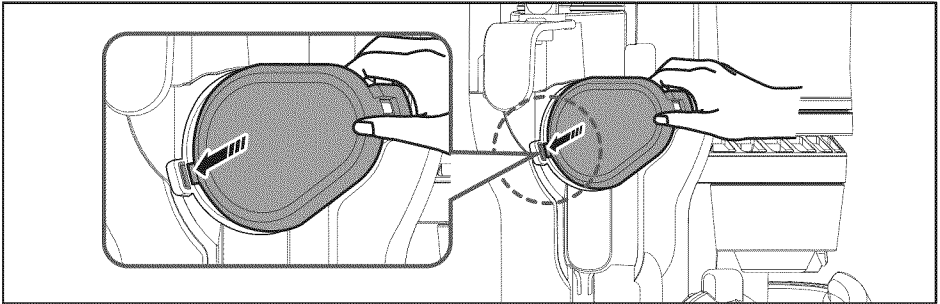

- Re-attach the cover after cleaning.

# Troubleshooting

Check this list of problems and possible solutions before bringing your vacuum to a service center.

<b>PROBLEM</b>	<b>SOLUTION</b>
<b>Vacuum won't run.</b>	<ul style="list-style-type: none"><li>• Check the electrical plug. Make sure it is fully plugged in.</li><li>• Press the Power on/off button.</li><li>• Reset overload protector.</li></ul>
<b>Suction Motor does not start. Thermal protector activated.</b>	<ul style="list-style-type: none"><li>• Allow the vacuum to cool.</li></ul>
<b>Brush Motor does not start.</b>	<ul style="list-style-type: none"><li>• Check the brush ON/OFF button.</li><li>• Cut hair or string off the brush.</li><li>• Reset the overload protector.</li></ul>
<b>Vacuum won't pick up or low suction.</b>	<ul style="list-style-type: none"><li>• Empty the dust bin.</li><li>• Clean the filter and confirm that the filter assembly is positioned properly.</li><li>• Check the hose connection or flow path.</li></ul>
<b>Dust escaping from the vacuum.</b>	<ul style="list-style-type: none"><li>• Empty the dust bin.</li><li>• Clean the pre-motor filters.</li><li>• Clean or replace the exhaust filter. (HEPA filter)</li><li>• Confirm that the filter assembly is positioned properly.</li></ul>
<b>Cleaner tools won't pick-up.</b>	<ul style="list-style-type: none"><li>• Check inlets, pipe, and dust bin for obstructions. Remove obstruction.</li><li>• Empty the dust bin.</li><li>• Remove and clean the filters.</li><li>• Confirm that the dust bin is locked properly.</li></ul>
<b>The sky blue button won't return to position after being pushed.</b>	<ul style="list-style-type: none"><li>• Check the diverter.</li><li>• Clean the cover and inside of diverter.</li></ul>

memo

---



If you have any questions or comments relating to Samsung products, please contact the SAMSUNG customer care center.

COUNTRY	CUSTOMER CARE CENTER	WEB SITE
U.S	1-800-SAMSUNG	<a href="http://www.samsung.com">www.samsung.com</a>
CANADA	1-800-SAMSUNG (726-7864)	<a href="http://www.samsung.com">www.samsung.com</a>

SÉRIE SU12F40

# Aspirateur manuel d'utilisation

- ※ Avant d'utiliser l'aspirateur, lisez attentivement le manuel d'utilisation.
- ※ Utilisation en intérieur uniquement.

Français

imagine the possibilities

Merci d'avoir choisi un produit Samsung.  
Afin de bénéficier d'un service plus complet,  
veuillez enregistrer votre produit à l'adresse :  
[www.samsung.com/register](http://www.samsung.com/register)

**SAMSUNG**

# Sommaire

---

## **VOTRE ASPIRATEUR**

06

- 06 Vue du produit
- 07 Contenu du carton d'emballage

## **AVANT D'UTILISER L'ASPIRATEUR**

08

- 08 Montez la poignée et le tube
- 09 Fixation des accessoires
- 10 Utilisation des accessoires

## **UTILISATION DE L'ASPIRATEUR**

11

- 11 Rangement du cordon d'alimentation
- 12 Allongement du tuyau
- 12 Utilisation du mode de position verticale
- 13 Utilisation du bouton On/Off (Marche/arrêt) de la barre de la brosse
- 13 Réinitialisation du protecteur contre surcharges
- 14 Utilisation du kit d'accessoires (en option)

## **MAINTENANCE**

16

- 16 Vider le réservoir de poussière
- 17 Nettoyage de la grille
- 18 Nettoyage du filtre avant moteur
- 20 Nettoyage du filtre HEPA
- 22 Vérification de la brosse
- 23 Vérification d'une éventuelle obstruction
- 24 Mini turbo brosse (en option)
- 25 Nettoyage de la protection de l'inverseur

## **DÉPANNAGE**

26

# Consignes de sécurité

## CONSIGNES DE SÉCURITÉ



Avant d'utiliser cet appareil, veuillez lire attentivement ce manuel et le conserver pour toute référence ultérieure.



Les instructions d'utilisation suivantes concernent plusieurs modèles ; il est donc possible que les caractéristiques de votre aspirateur soient légèrement différentes de celles spécifiées dans ce manuel.

## SYMBOLES ATTENTION/AVERTISSEMENT UTILISÉS

	Indique un risque de blessures graves ou mortelles.
	Indique un risque de blessure ou de dégât matériel.

## AUTRES SYMBOLES UTILISÉS

	Indique une action INTERDITE.
	Indique des instructions que vous devez suivre.
	Indique que vous devez débrancher la fiche d'alimentation de la prise.



Cet aspirateur est destiné à une utilisation domestique uniquement.  
Ne l'utilisez pas pour le nettoyage de saletés ou débris provenant de la construction.  
Nettoyez les filtres régulièrement afin d'éviter l'infiltration de toute poussière fine.  
N'utilisez pas cet aspirateur lorsque l'un des filtres a été retiré.

**Le non-respect de ces consignes peut provoquer des blessures, endommager l'aspirateur et annuler la garantie.**

# consignes de sécurité

---

## CONSIGNES IMPORTANTES DE SÉCURITÉ

---

Lors de l'utilisation d'un appareil électrique, suivez toujours ces précautions de base :

### LISEZ TOUTES LES INSTRUCTIONS AVANT D'UTILISER VOTRE ASPIRATEUR BALAI

### AVERTISSEMENT – POUR LIMITER TOUT RISQUE D'INCENDIE, D'ÉLECTROCUTION OU DE BLESSURE :

1. Ne laissez pas l'aspirateur sans surveillance lorsqu'il est branché.  
Débranchez-le lorsque vous ne l'utilisez pas ou avant toute opération d'entretien.
2. N'utilisez pas l'appareil à l'extérieur ni sur des surfaces mouillées.
3. Cet aspirateur ne doit pas être utilisé comme un jouet.  
Prêtez une attention particulière aux enfants qui vous entourent lorsque vous utilisez l'aspirateur.
4. Utilisez cet appareil uniquement tel qu'indiqué dans le présent manuel. Utilisez des accessoires recommandés par le fabricant uniquement.
5. N'utilisez jamais de cordon ou de prise endommagé(e).  
Si l'aspirateur fonctionne anormalement, a reçu un choc, a été endommagé, laissé à l'extérieur ou plongé dans l'eau, retournez-le au centre d'assistance.
6. Ne tirez pas sur le cordon ; ne soulevez pas l'appareil par le cordon ; n'utilisez pas le cordon comme poignée ; ne fermez pas de porte sur le cordon ; ne tirez pas le cordon sur des rebords ou des angles coupants ;  
Ne placez pas l'aspirateur sur le cordon.  
Maintenez le cordon éloigné des surfaces chauffées.
7. Ne débranchez pas l'appareil en tirant sur le cordon. Pour débrancher, tenez la prise et non le cordon.
8. Ne manipulez pas la prise ou l'aspirateur si vous avez les mains mouillées.
9. N'insérez aucun objet dans les ouvertures ou orifices de ventilation. N'utilisez pas l'appareil si l'une des ouvertures est obstruée.  
Nettoyez régulièrement les ouvertures pour éliminer toute trace de poussière, peluches, cheveux, ou toute autre chose risquant d'empêcher le passage de l'air.
10. Maintenez les cheveux, les vêtements larges, les doigts et toute autre partie de votre corps loin des ouvertures et des pièces en mouvement.
11. Mettez hors tension tous les contrôles avant de débrancher l'appareil.
12. Soyez très prudent lorsque vous nettoyez les escaliers.
13. N'aspirez jamais de liquides inflammables ou combustibles tels que de l'essence et n'utilisez jamais l'appareil si de tels liquides risquent d'être présents.



14. N'aspirez jamais d'objets en train de brûler ou de fumer, tels que des cigarettes, des allumettes ou des cendres chaudes.
15. N'utilisez pas l'aspirateur si le bac à poussière et/ou les filtres ne sont pas à leur place.
16. N'utilisez pas l'aspirateur dans un espace clos rempli de vapeurs de peinture à l'huile, de diluant, de substances antimites, de poussières inflammables et autres éléments explosifs ou toxiques.
17. Stockez votre aspirateur à l'intérieur dans une pièce sèche et fraîche.
18. Utilisez-le uniquement à l'intérieur et sur des surfaces sèches.
19. N'utilisez pas la prise polarisée avec une prise murale ou une rallonge non-polarisée.
20. Ne touchez pas le tambour de la brosse pendant qu'il pivote.
21. Maintenez l'aspiration éloignée de votre visage lorsque vous utilisez les suceurs et le tube.
22. Ne tirez pas le cordon d'alimentation sur des angles coupants et veillez à ce qu'il ne se coince pas.
23. Cet aspirateur n'est pas conçu pour être utilisé par des personnes (y compris les enfants) inexpérimentées ou dont les capacités physiques, sensorielles ou mentales sont réduites, sauf si celles-ci sont sous la surveillance ou ont reçu les instructions d'utilisation appropriées de la personne responsable de leur sécurité.
24. Les enfants ne doivent pas utiliser l'aspirateur sans la surveillance d'un adulte.
25. La fiche doit être débranchée de la prise avant toute opération de nettoyage ou de maintenance sur l'aspirateur.
26. Si le cordon d'alimentation est endommagé, il doit être remplacé par le fabricant, un technicien de maintenance ou toute autre personne qualifiée.
27. Tenez la fiche lorsque vous rembobinez le cordon afin d'éviter qu'il ne vous blesse.
28. N'aspirez jamais d'objets pointus ou tranchants tels que des morceaux de verres, des clous, des vis, des pièces de monnaie, etc.
29. Mettez toujours cet aspirateur hors tension avant de connecter ou déconnecter l'aspirateur portable.
30. Ne touchez pas les grilles d'aération lorsque la température d'évacuation est élevée.

## CONSERVEZ CE MANUEL D'UTILISATION

### INSTRUCTIONS DES PRISES POLARISÉES

- Pour limiter les risques d'électrocution, cet appareil dispose d'une prise polarisée (une broche est plus large que l'autre).  
Cette prise ne doit s'insérer dans la prise murale polarisée que dans un seul sens.  
Si la prise ne s'enfonce pas entièrement dans la prise murale, retournez-la.  
Si elle ne s'enfonce toujours pas correctement, contactez un électricien qualifié pour faire installer une prise murale adéquate.  
Ne modifiez jamais la prise.

### Avertissement de la proposition 65 de l'État de Californie (États-Unis uniquement)



Ce produit contient des substances chimiques considérées par l'État de Californie comme étant cancérigène ou à l'origine de troubles de la reproduction.

# Votre aspirateur

## VUE DU PRODUIT

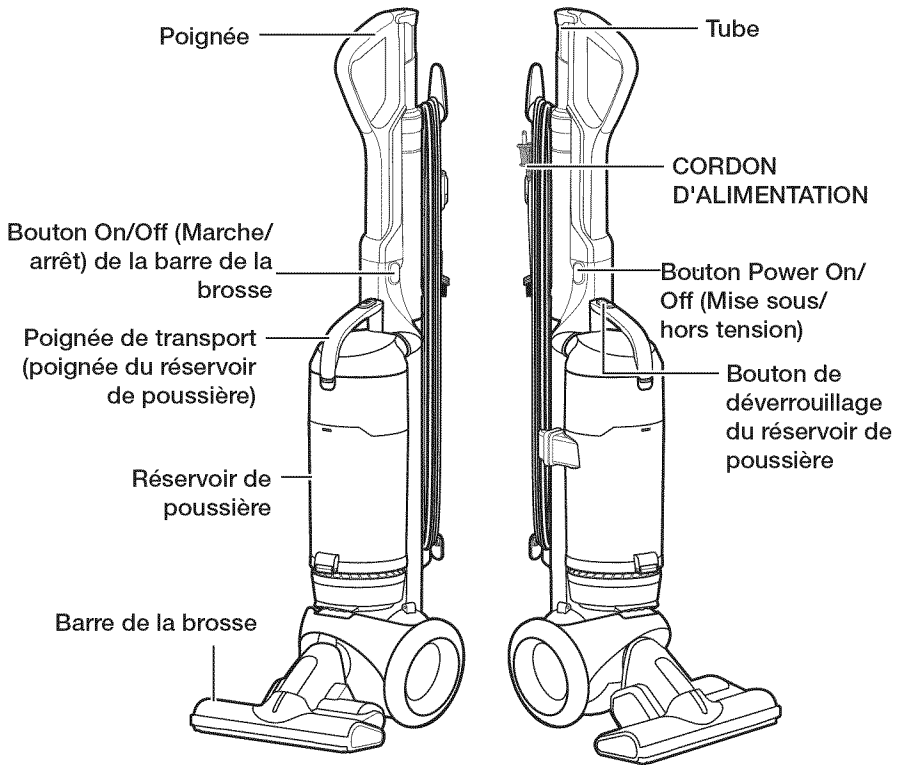

Ne branchez pas l'aspirateur avant que vous soyez familiarisé avec toutes les instructions et procédures de fonctionnement.



Le film en plastique peut présenter un danger.  
Pour éviter tout risque d'étouffement, éloignez le film des bébés et enfants.

## CONTENU DU CARTON D'EMBALLAGE

---

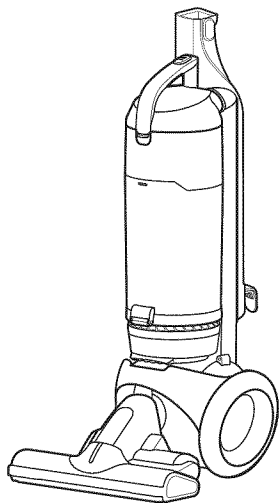

(1)

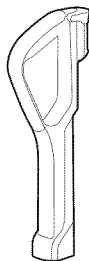

(2)

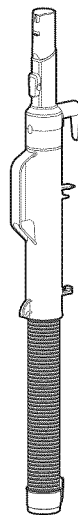

(3)



(4)

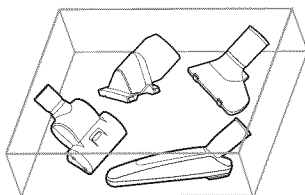

(5)



(6)

- Videz le carton. Recherchez toutes les pièces présentées ci-dessus avant de jeter l'emballage.

1. Corps de l'aspirateur
2. Poignée
3. Tube
4. Accessoire 2 en 1
5. Kit d'accessoires (en option, selon le modèle)
6. Manuel d'utilisation

# Avant d'utiliser l'aspirateur

## MONTEZ LA POIGNÉE ET LE TUBE

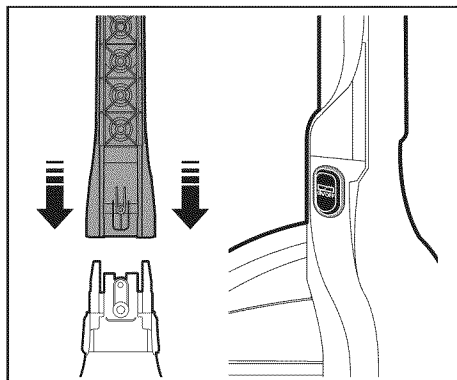

- Raccordez la poignée et le corps.

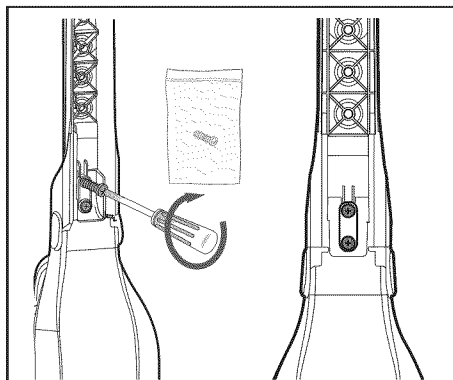

- Ouvrez l'emballage de la vis puis serrez-la à l'aide d'un tournevis cruciforme (+) comme indiqué sur le schéma.

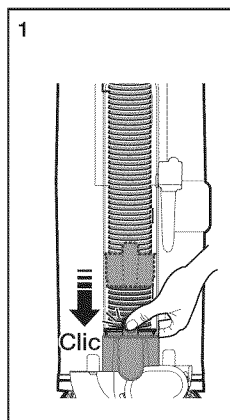

1. Tenez l'aspirateur debout, puis insérez le fond du tuyau dans le trou du corps jusqu'à entendre un clic.

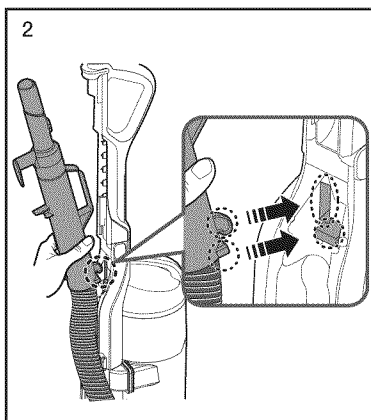

2. Insérez le crochet situé sur la partie haute du tuyau dans le trou situé sur la poignée comme indiqué sur le schéma. Le crochet doit repousser le bouton bleu ciel dans la poignée.

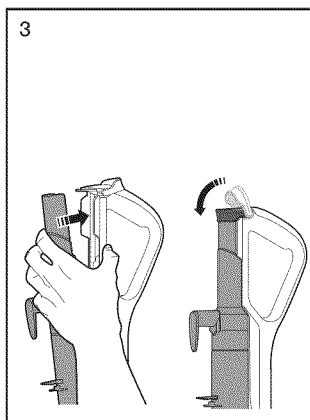

3. Fixez le haut du tuyau sur la poignée, puis couvrez avec le cache.

- Enroulez le cordon autour des crochets de cordon et fixez-le à l'aide du clip.

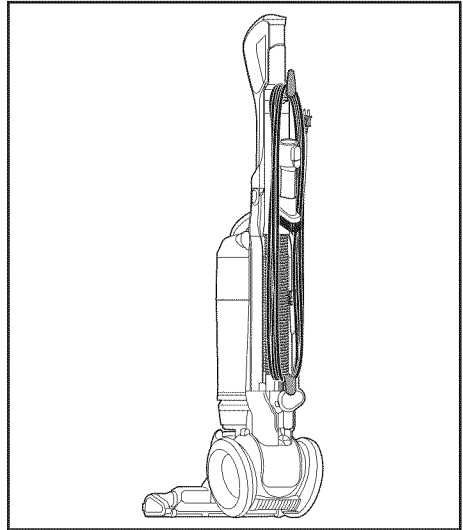

## FIXATION DES ACCESSOIRES

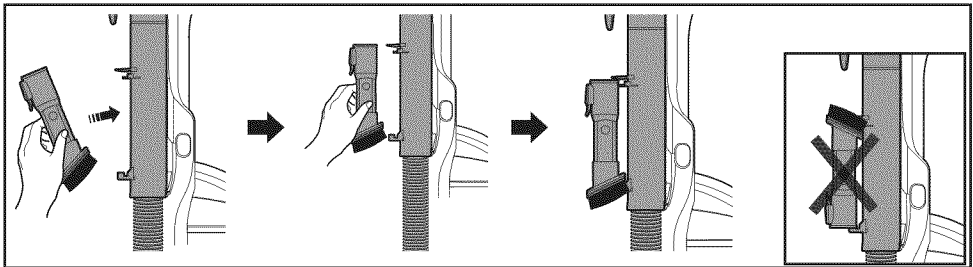

## UTILISATION DES ACCESSOIRES

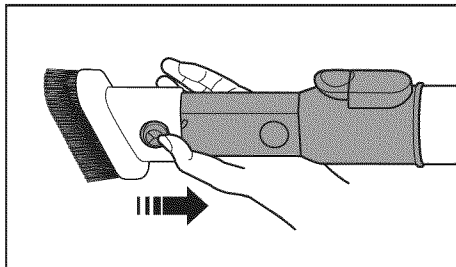

- Suceur plat

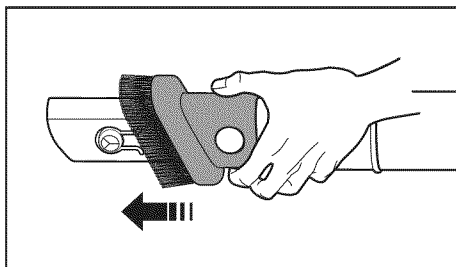
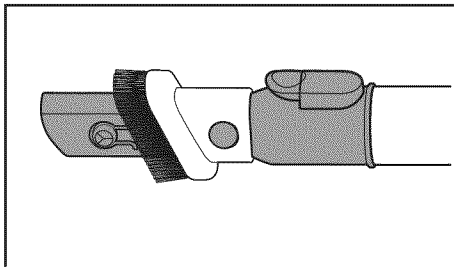

- Brosse à épousseter

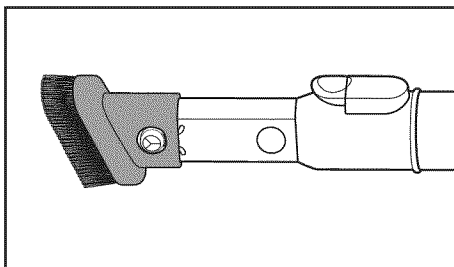

# Utilisation de l'aspirateur

## RANGEMENT DU CORDON D'ALIMENTATION

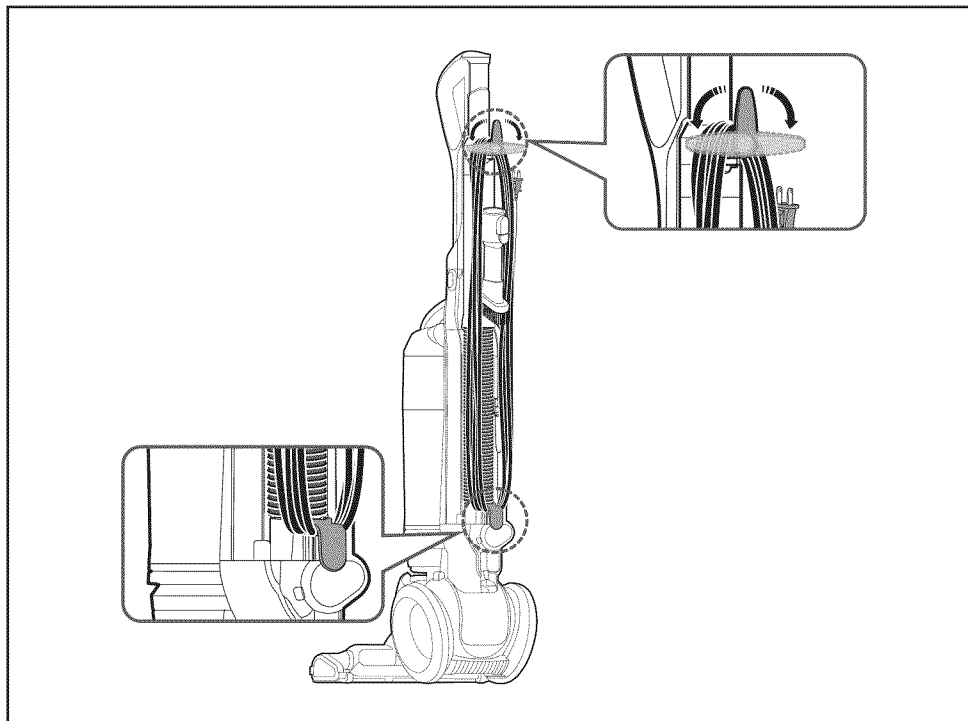

Lorsque vous débranchez la fiche d'une prise électrique, tenez la fiche, non le cordon.

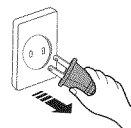

## ALLONGEMENT DU TUYAU

### Mode de tuyau

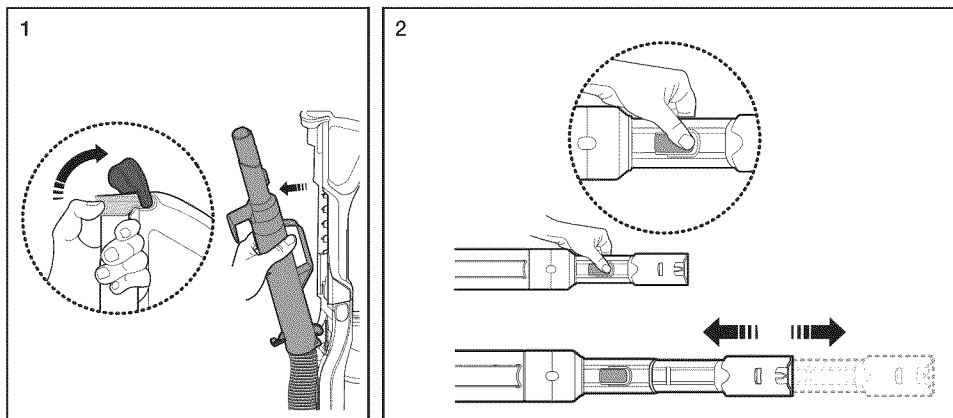

- Poussez le cache de la poignée vers le haut, puis retirez le tuyau du corps.
- Poussez le bouton sur le tuyau afin d'allonger le tuyau.

## UTILISATION DU MODE DE POSITION VERTICALE

### Mode de position verticale

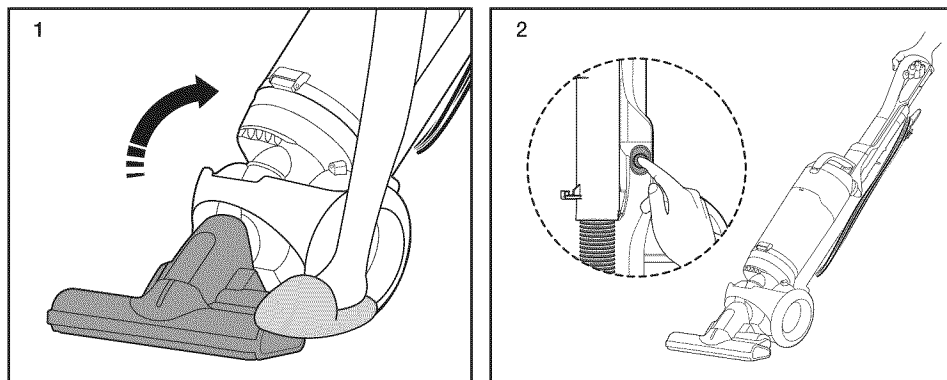

- Placez un pied sur la brosse, puis rebasculez doucement la poignée pour débloquer le verrou.
- Appuyez sur le bouton Power On/Off (Mise sous/hors tension).



## UTILISATION DU BOUTON ON/OFF (MARCHE/ARRÊT) DE LA BARRE DE LA BROSSE

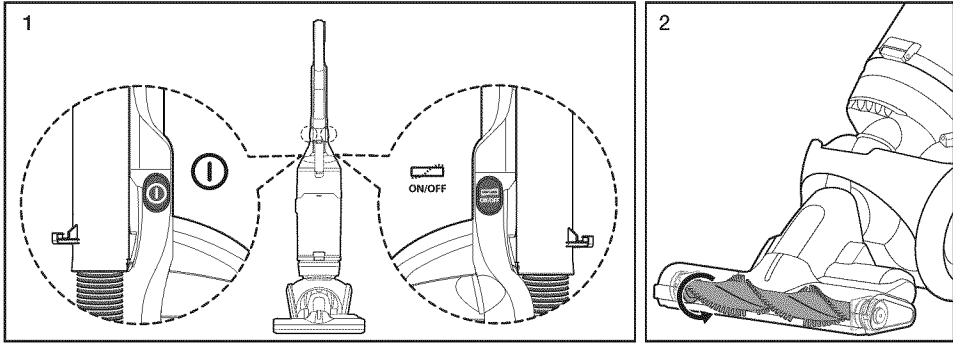

- Appuyez sur le bouton Power On/Off (Mise sous/hors tension), puis appuyez sur le bouton On/Off (Marche/arrêt) de la barre de la brosse.



En position verticale, la barre de la brosse ne fonctionne pas.

## RÉINITIALISATION DU PROTECTEUR CONTRE SURCHARGES

- Le protecteur contre surcharges coupe le moteur de la brosse si la barre de la brosse se bouche.  
Pour réinitialiser le protecteur contre surcharges, utilisez la pointe d'un stylo pour appuyer sur le bouton de réinitialisation.

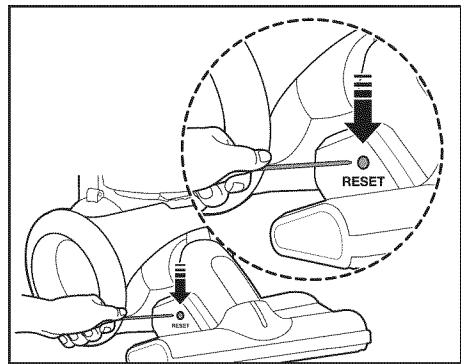

## UTILISATION DE LA POIGNÉE DE L'ASPIRATEUR (LA POIGNÉE DU RÉSERVOIR DE POUSSIÈRE)

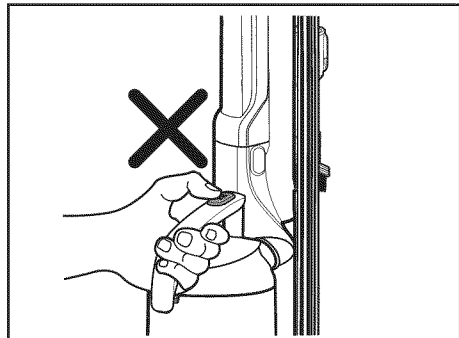
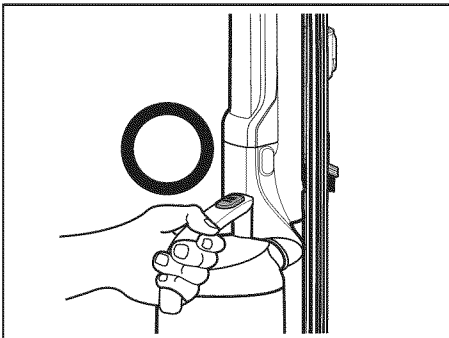

Lorsque vous transportez l'aspirateur à l'aide de la poignée, n'appuyez pas sur le bouton de déverrouillage du réservoir de poussière.

## UTILISATION DU KIT D'ACCESSOIRES (EN OPTION)

### Accessoire pour meubles

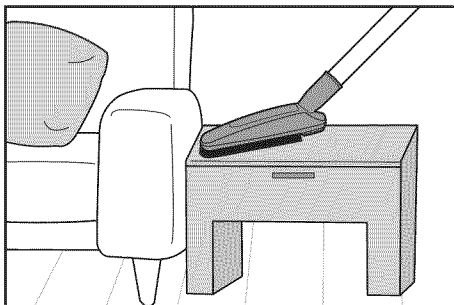
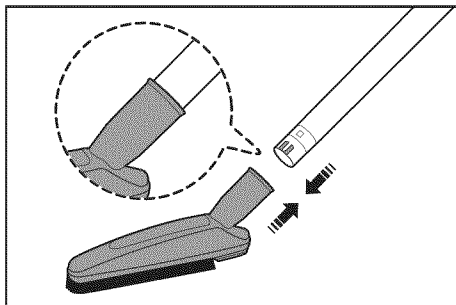

Tissus

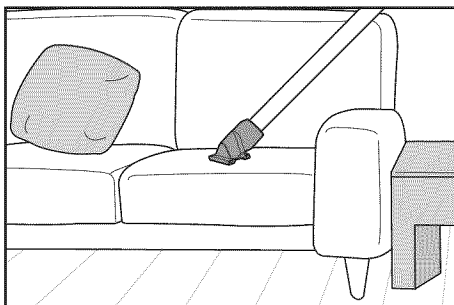
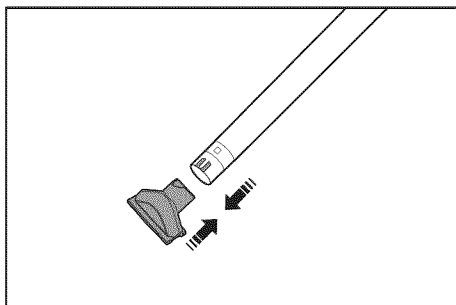

Mini turbo brosse

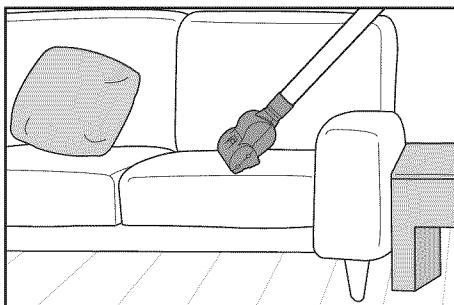
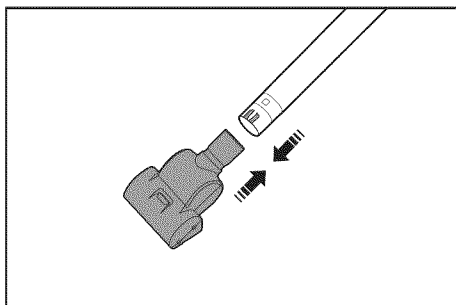

## Accessoire pour animaux

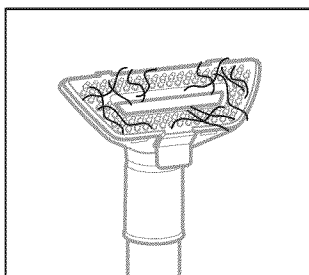
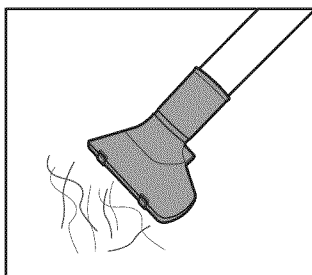
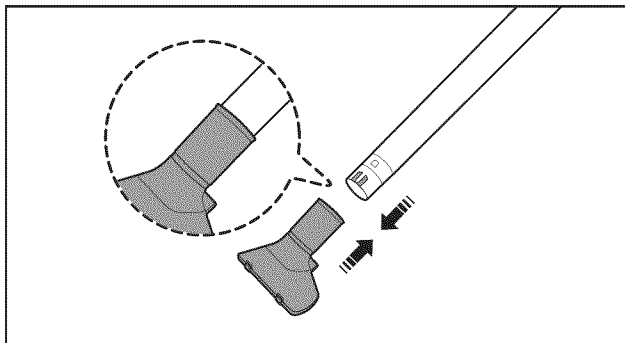

- Ratissez les poils.

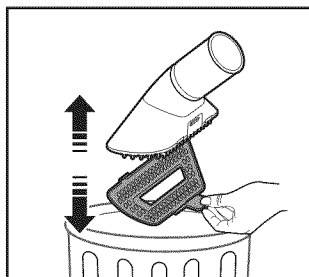
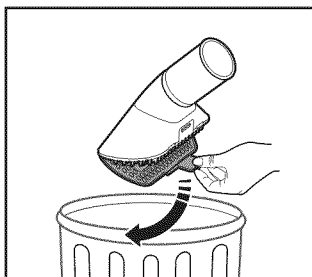

- Retirez le couvercle de l'accessoire pour animaux, puis jetez les poils.

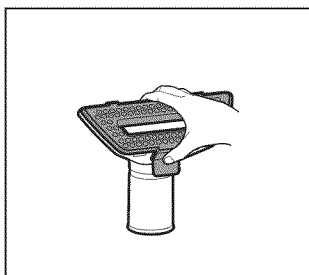
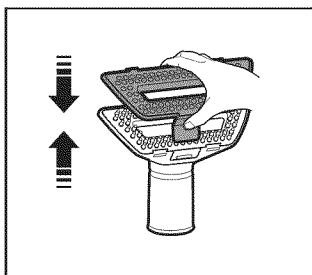

- Remontez le couvercle.

# Maintenance

## VIDER LE RÉSERVOIR DE POUSSIÈRE

- Videz le réservoir de poussière lorsque la poussière atteint le repère « MAX ».
- Sortez le réservoir de poussière en appuyant sur le bouton de la poignée.

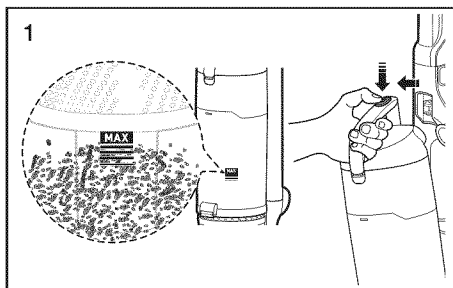

- Pour vider le réservoir de poussière, maintenez-le au-dessus d'une poubelle, puis poussez le bouton vers le bas du réservoir.

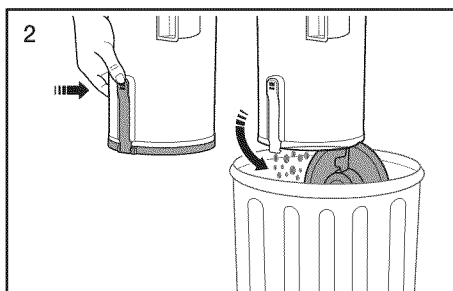

- Pour éliminer le contenu du vide-poussière, maintenir le vide-poussière dans un sac en plastique, puis appuyer sur le bouton près du bas du vide-poussière.  
(Recommandé pour les personnes souffrant d'asthme/allergies.)

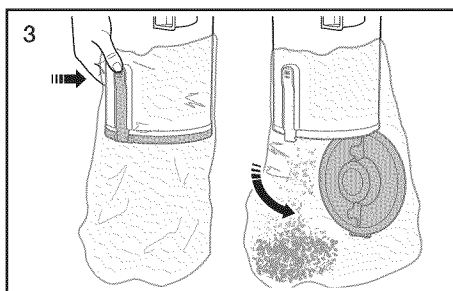

- Fermer le fond du vide-poussière, puis déposer le sac plastique dans la poubelle.  
(Recommandé pour les personnes souffrant d'asthme/allergies.)

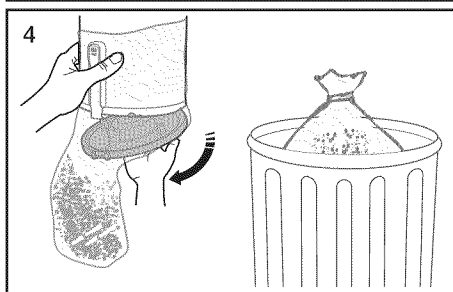

## NETTOYAGE DE LA GRILLE

- Séparez le réservoir de poussière du corps de l'aspirateur.

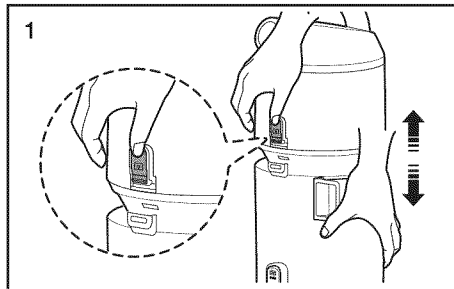

- Nettoyez la grille avec la brosse à épousseter pour éliminer les peluches.

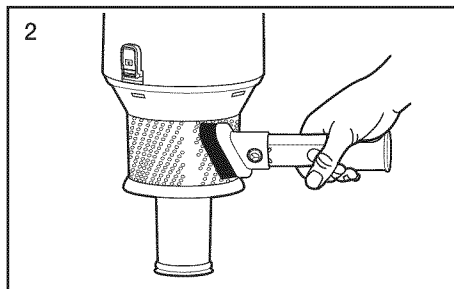

- Pour rattacher le réservoir de poussière au corps de l'aspirateur, suivez les étapes 3 et 4.

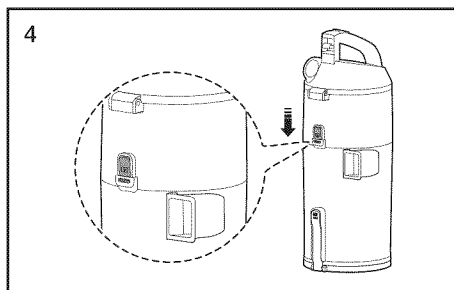
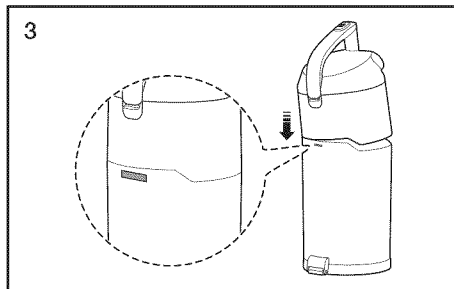

## NETTOYAGE DU FILTRE AVANT MOTEUR

- Tirez le couvercle du réservoir à poussière pour l'ouvrir.

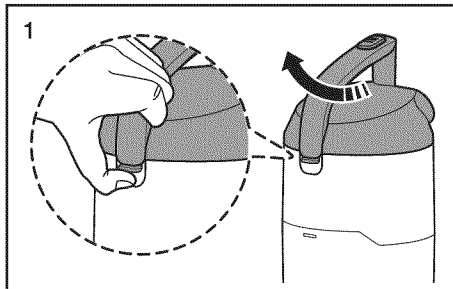

- Retirez le filtre du réservoir à poussière.

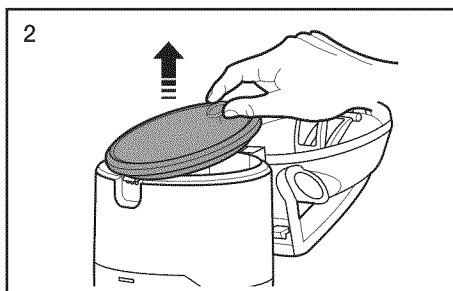

- Secouez le filtre pour éliminer la poussière, puis lavez le filtre à l'eau claire.

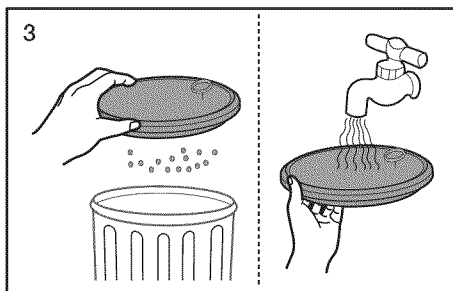

- Laissez le filtre entièrement sécher à l'abri du soleil.

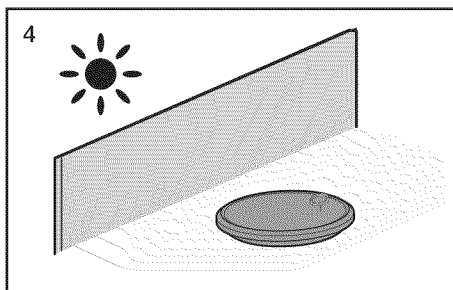

- Remplacez le filtre dans le réservoir à poussière.

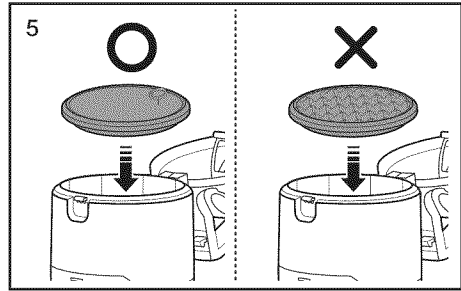

Vérifiez le filtre régulièrement et lavez-le tous les un à deux mois.  
 Veillez à ce que le filtre soit totalement sec avant de le replacer dans l'aspirateur.  
 Laissez-le sécher pendant 12 heures.  
 N'utilisez pas un filtre mouillé.  
 Remplacez le filtre à poussière s'il est endommagé ou déformé.  
 Le couvercle du réservoir de poussière ne se ferme pas si le filtre n'est pas installé correctement.



## NETTOYAGE DU FILTRE HEPA

- Sortez le réservoir de poussière en appuyant sur le bouton de la poignée.

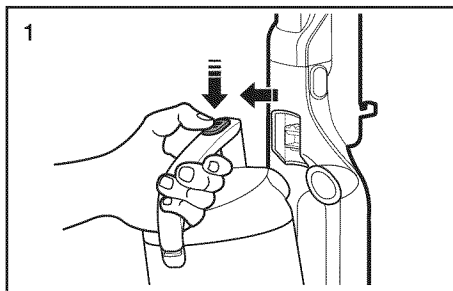

- Retirez le couvercle du filtre.

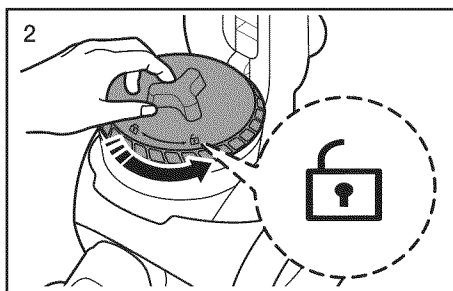

- Retirez le filtre HEPA du corps de l'aspirateur.

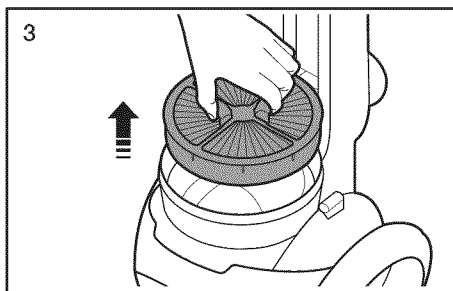

- Secouez le filtre pour retirer toute poussière.

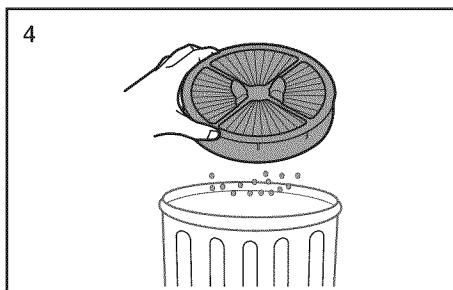

Nettoyez le filtre HEPA lorsque l'aspiration est considérablement et continuellement réduite ou lorsque l'aspirateur surchauffe anormalement.

Remarque : Les filtres HEPA ne sont pas lavables.

Remplacez le filtre si son nettoyage ne résout pas le problème.



- Re-insérez le filtre dans le corps de l'aspirateur.

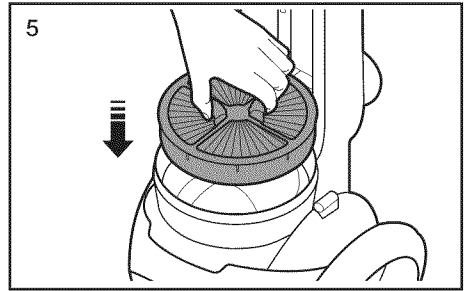

- Remontez le filtre et son couvercle.

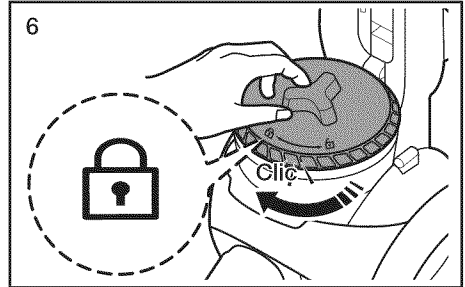

- Fixez à nouveau le réservoir de poussière sur l'aspirateur.

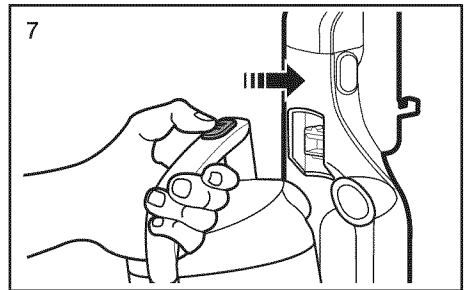

Le réservoir de poussière ne peut pas être refixé sur l'aspirateur si le couvercle du filtre n'est pas installé correctement.

## VÉRIFICATION DE LA BROSSE

- Mettez l'aspirateur hors tension et débranchez-le. Posez l'aspirateur au sol pour que la partie inférieure soit accessible comme indiqué.

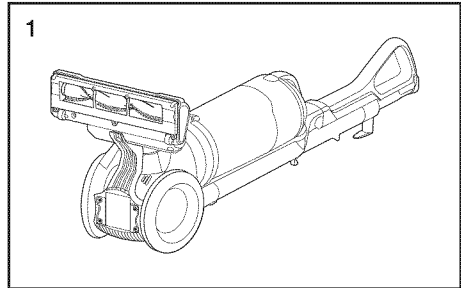

- Coupez doucement d'éventuels cheveux ou bouts de ficelle coincés dans la brosse.

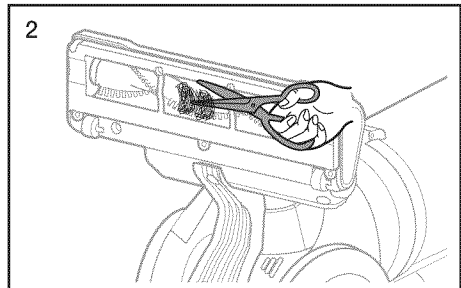

Avant d'inspecter la barre de la brosse, éteignez-la et débranchez l'aspirateur.

## VÉRIFICATION D'UNE ÉVENTUELLE OBSTRUCTION

- Placez un pied sur la brosse, puis rebasculez doucement la poignée pour débloquer le verrou.

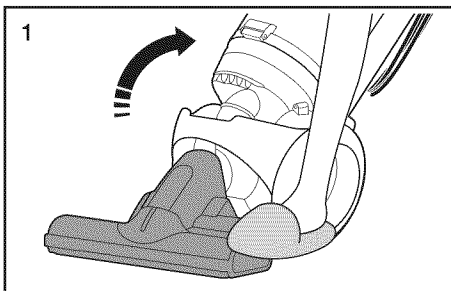

- Appuyez sur le bouton de déverrouillage sur le logement de la brosse, puis retirez le tuyau.

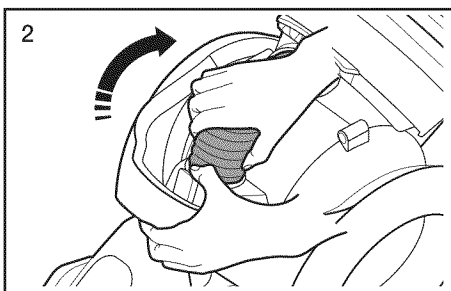

- Vérifiez la présence d'une éventuelle obstruction dans l'ouverture du logement de la brosse et dans le tuyau.

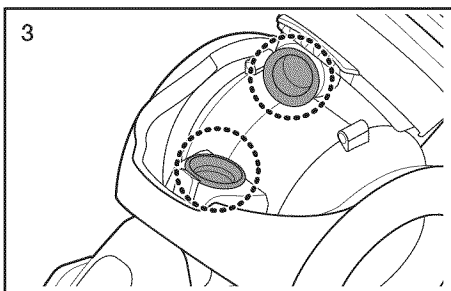

- Une fois vérifié, refixez le tuyau sur le logement de la brosse.

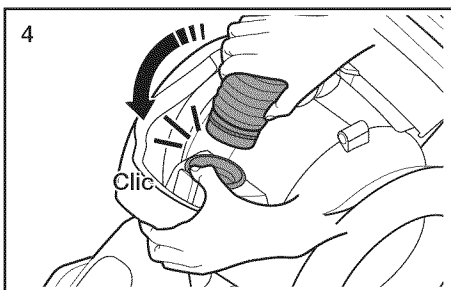

Avant de vérifier s'il existe une obstruction, éteignez la barre de la brosse et débranchez l'aspirateur.

## MINI TURBO BROSSE (EN OPTION)

### INSPECTION DE LA BROSSE ROULEAU

- Si vous constatez que la brosse est obstruée par des débris, inspectez la brosse rouleau.

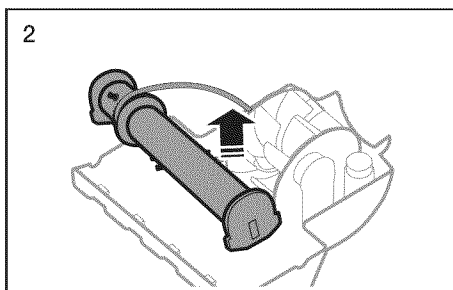
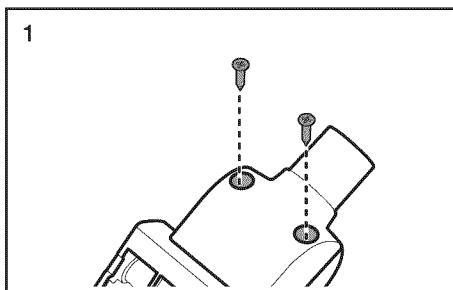

### INSPECTION DE LA COURROIE

- Si la courroie présente des fissures ou des cassures, remplacez-la en suivant les instructions situées sur la droite.

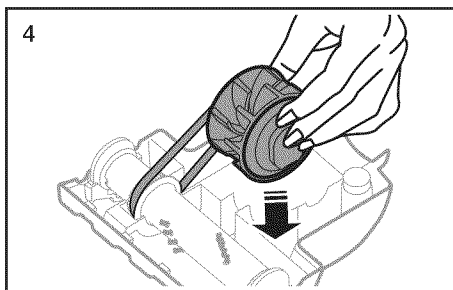
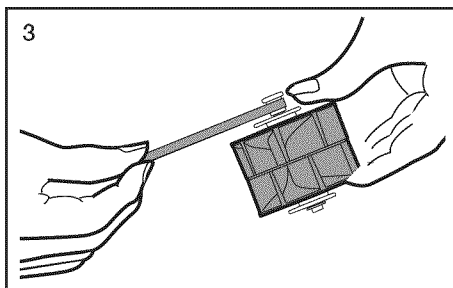

## NETTOYAGE DE LA PROTECTION DE L'INVERSEUR

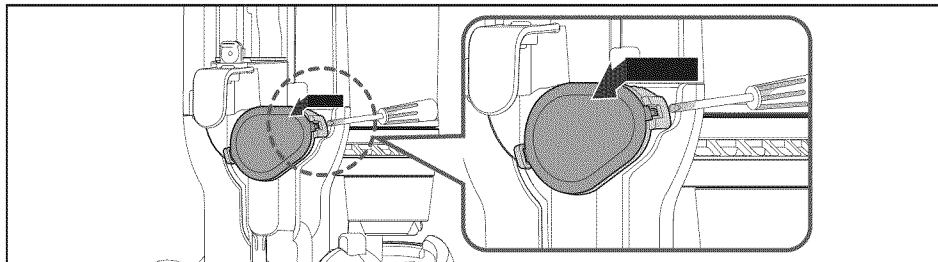

- Ouvrez la protection de l'inverseur à l'aide d'un tournevis à tête plate (-).

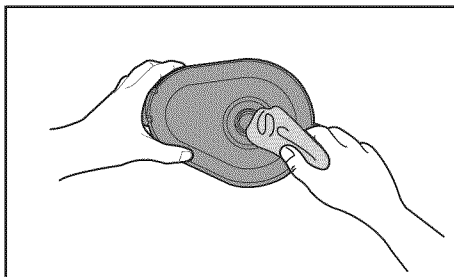
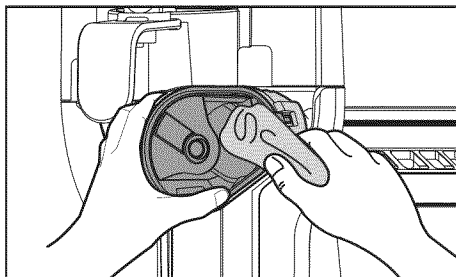

- Nettoyez l'intérieur de la protection à l'aide d'un chiffon sec.

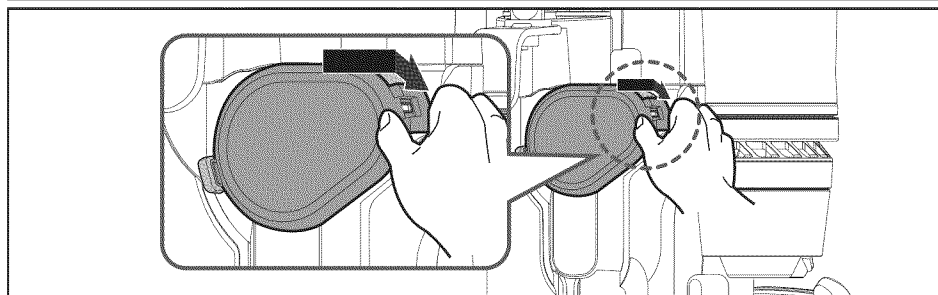
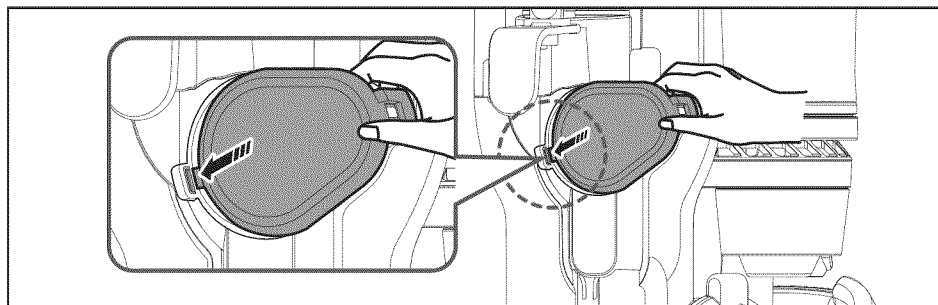

- Remontez le couvercle après avoir nettoyé.

# Dépannage

Vérifiez cette liste des problèmes possibles et des solutions avant de contacter le centre d'assistance.

PROBLÈME	SOLUTION
L'aspirateur ne fonctionne pas.	<ul style="list-style-type: none"><li>• Vérifiez la prise électrique. Vérifiez si l'aspirateur est correctement branché.</li><li>• Appuyez sur le bouton Power On/Off (Mise sous/hors tension).</li><li>• Réinitialisez le protecteur contre surcharges.</li></ul>
Le moteur d'aspiration ne démarre pas. L'interrupteur thermique est activé.	<ul style="list-style-type: none"><li>• Laissez l'aspirateur refroidir.</li></ul>
Le moteur de la brosse ne démarre pas.	<ul style="list-style-type: none"><li>• Appuyez sur le bouton ON/OFF (MARCHE/ARRÊT) de la brosse.</li><li>• Retirez d'éventuels cheveux et bouts de ficelle de la brosse.</li><li>• Réinitialisez le protecteur contre surcharges.</li></ul>
L'aspirateur n'aspire pas ou aspire faiblement.	<ul style="list-style-type: none"><li>• Videz le réservoir de poussière.</li><li>• Nettoyez le filtre et vérifiez si l'assemblage du filtre est correctement mis en place.</li><li>• Vérifiez la connexion du tuyau et le passage d'air.</li></ul>
De la poussière s'échappe de l'aspirateur.	<ul style="list-style-type: none"><li>• Videz le réservoir de poussière.</li><li>• Nettoyez les filtres avant moteur.</li><li>• Nettoyez ou remplacez le filtre d'évacuation. (Filtre HEPA)</li><li>• Confirmez que l'assemblage du filtre est correctement mis en place.</li></ul>
Les accessoires de l'aspirateur n'aspirent pas.	<ul style="list-style-type: none"><li>• Vérifiez si les orifices d'entrée, le tube ou le réservoir de poussière sont obstrués. Éliminez l'obstruction.</li><li>• Videz le réservoir de poussière.</li><li>• Retirez et nettoyez les filtres.</li><li>• Confirmez que le réservoir de poussière est correctement verrouillé.</li></ul>
Le bouton bleu ciel ne revient pas en position après avoir été poussé.	<ul style="list-style-type: none"><li>• Contrôlez l'inverseur.</li><li>• Nettoyez la protection et l'intérieur de l'inverseur.</li></ul>

mémo

---



Si vous avez des questions ou des commentaires sur les produits Samsung, contactez le centre d'assistance clientèle SAMSUNG.

<b>PAYS</b>	<b>CENTRE D'ASSISTANCE CLIENTÈLE</b>	<b>SITE WEB</b>
ÉTATS-UNIS	1-800-SAMSUNG	<a href="http://www.samsung.com">www.samsung.com</a>
CANADA	1-800-SAMSUNG (726-7864)	<a href="http://www.samsung.com">www.samsung.com</a>



SERIE SU12F40

# Aspiradora manual del usuario

\* Antes de poner en funcionamiento la aspiradora, lea el Manual del usuario en su totalidad.

\* Solo para uso en interiores.

Español

imagine the possibilities

Gracias por adquirir un producto Samsung.

Para recibir un servicio más completo,

registre su producto en

[www.samsung.com/register](http://www.samsung.com/register)

**SAMSUNG**

# Índice

---

## **SU ASPIRADORA**

06

- 06 Vista del producto
- 07 Contenido del embalaje

## **ANTES DE UTILIZAR LA ASPIRADORA**

08

- 08 Montaje del mango y del tubo
- 09 Montaje de los accesorios
- 10 Uso de los accesorios

## **FUNCIONAMIENTO DE LA ASPIRADORA**

11

- 11 Recogida del cable de alimentación
- 12 Alargamiento del tubo
- 12 Uso del modo vertical
- 13 Funcionamiento del conmutador de activación/desactivación de la barra del cepillo
- 13 Reinicio del protector contra sobrecarga
- 13 Uso del mango de la aspiradora (mango del contenedor de polvo)
- 14 Uso del kit de accesorios (opcional)

## **MANTENIMIENTO**

16

- 16 Vaciado del contenedor de polvo
- 17 Limpieza de la rejilla
- 18 Limpieza del filtro premotor
- 20 Limpieza del filtro HEPA
- 22 Comprobación del cepillo
- 23 Comprobación de obstrucciones
- 24 Cepillo miniturbo (opcional)
- 25 Limpieza de la cubierta del desviador

## **SOLUCIÓN DE PROBLEMAS**

26

# Información de seguridad

## INFORMACIÓN DE SEGURIDAD



Antes de poner el aparato en funcionamiento, lea este manual en su totalidad y consérvelo para futuras consultas.



Las siguientes instrucciones de funcionamiento se aplican a varios modelos, por lo que las características de su aspiradora pueden variar ligeramente de las descritas en este manual.

## SÍMBOLOS DE PRECAUCIÓN/ADVERTENCIA UTILIZADOS

	Indica que hay riesgo de muerte o lesiones graves.
	Indica que hay riesgo de lesiones personales o daños materiales.

## OTROS SÍMBOLOS UTILIZADOS

	Indica algo que el usuario NO debe hacer.
	Indica instrucciones que se deben seguir.
	Indica que se debe desenchufar el cable de alimentación de la toma de corriente.



La aspiradora está destinada únicamente a uso doméstico.

No utilice la aspiradora para eliminar escombros.

Limpie los filtros regularmente para impedir la acumulación de polvo fino.

No utilice esta aspiradora sin ningún filtro instalado.

**El incumplimiento de estas instrucciones puede causar lesiones graves, daños a la aspiradora e invalidación de la garantía**

## **INSTRUCCIONES DE SEGURIDAD IMPORTANTES**

---

Cuando se utilicen electrodomésticos, se deben seguir siempre estas precauciones básicas de seguridad:

### **LEA TODAS LAS INSTRUCCIONES ANTES DE UTILIZAR LA ASPIRADORA VERTICAL**

### **ADVERTENCIA – PARA REDUCIR EL RIESGO DE INCENDIO, DESCARGA ELÉCTRICA O LESIONES:**

1. No deje la aspiradora enchufada sin vigilancia.  
Desenchúfela cuando no la utilice y antes de realizar tareas de mantenimiento.
2. No la utilice en exteriores ni sobre superficies húmedas.
3. No permita que se utilice la aspiradora como juguete.  
Vigile atentamente cuando el aparato lo utilice un niño o haya niños cerca.
4. Utilícela únicamente como se describe en este manual. Utilice solo los accesorios recomendados por el fabricante.
5. No la utilice si el cable o el enchufe están dañados.  
Si la aspiradora no funciona correctamente, ha sufrido alguna caída, se ha dañado, ha permanecido al aire libre o se ha mojado, llévela a un centro de servicio técnico.
6. No tire del cable ni lo utilice para desplazar la aspiradora, no lo utilice como asa, no lo aplaste al cerrar una puerta ni tire de él contra bordes o esquinas puntiagudas.  
No pase la aspiradora sobre el cable.  
Mantenga el cable alejado de superficies calientes.
7. No tire del cable para desenchufar la aspiradora. Para desenchufarla tire del enchufe, no del cable.
8. No toque el enchufe ni la aspiradora con las manos húmedas.
9. No introduzca ningún objeto en las aberturas ni en las rejillas de ventilación. No utilice la aspiradora si hay alguna abertura obstruida.  
Manténgala libre de polvo, pelusa, cabellos y cualquier elemento que pueda reducir el flujo de aire.
10. Mantenga el cabello, la ropa suelta, los dedos y todas las partes del cuerpo alejados de las aberturas y las piezas móviles.
11. Desactive todos los controles antes de desenchufarla.
12. Tenga especial cuidado cuando limpie escaleras.
13. No aspire líquidos inflamables o combustibles, como gasolina, ni utilice la unidad en zonas donde éstos puedan estar presentes.
14. No aspire nada que esté ardiendo o humeando, como cigarrillos, fósforos o cenizas

- calientes.
15. No la utilice sin el depósito o los filtros colocados en su lugar.
  16. No utilice la aspiradora en un lugar cerrado donde se concentren vapores desprendidos de pinturas a base de aceite, disolventes, productos antipolilla, polvo inflamable u otros vapores explosivos o tóxicos.
  17. Guarde la aspiradora en el interior, en un lugar fresco y seco.
  18. Utilícela solo en superficies de interior que estén secas.
  19. No modifique el enchufe polarizado para que se adapte a otro no polarizado o a un cable alargador.
  20. No toque el rodillo del cepillo cuando esté girando.
  21. Mantenga la succión alejada del rostro cuando utilice las boquillas y el tubo.
  22. No tire del cable contra esquinas puntiagudas y tenga cuidado de que no quede atrapado.
  23. Esta aspiradora no está diseñada para que la usen personas (incluidos los niños) con discapacidad física, mental y sensorial, o faltas de conocimiento y experiencia, sin la supervisión o las indicaciones de una persona responsable que garantice un uso seguro del aparato.
  24. No deje que los niños jueguen con la aspiradora.
  25. Debe desenchufar la aspiradora cuando desee limpiarla o realizar tareas de mantenimiento.
  26. Si el cable de alimentación está dañado, lo debe reemplazar el fabricante o bien un técnico de servicio o personal igualmente cualificado.
  27. Sujete el enchufe cuando enrolle el cable. No deje que el enchufe dé latigazos al enrollarlo.
  28. No aspire objetos duros o afilados como cristales, clavos, tornillos, monedas, etc.
  29. Apague siempre la aspiradora antes de conectar o desconectar la aspiradora de mano.
  30. No toque la rejilla de ventilación cuando el aire de salida está caliente.

## CONSERVE ESTAS INSTRUCCIONES

### INSTRUCCIONES SOBRE EL ENCHUFE POLARIZADO

- Para reducir el riesgo de descargas eléctricas, este aparato cuenta con un enchufe polarizado (una clavija es más ancha que la otra). Este enchufe encaja en la toma solo en una dirección. Si el enchufe no encaja correctamente en la toma, gírelo. Si sigue sin encajar, póngase en contacto con un técnico cualificado para instalar una toma adecuada. No modifique el enchufe de ninguna manera.

### Advertencia de la Proposición 65 del Estado de California (solo EE.UU.)



Este producto contiene sustancias químicas que, según el Estado de California, provocan cáncer y toxicidad reproductiva.

# Su aspiradora

## VISTA DEL PRODUCTO

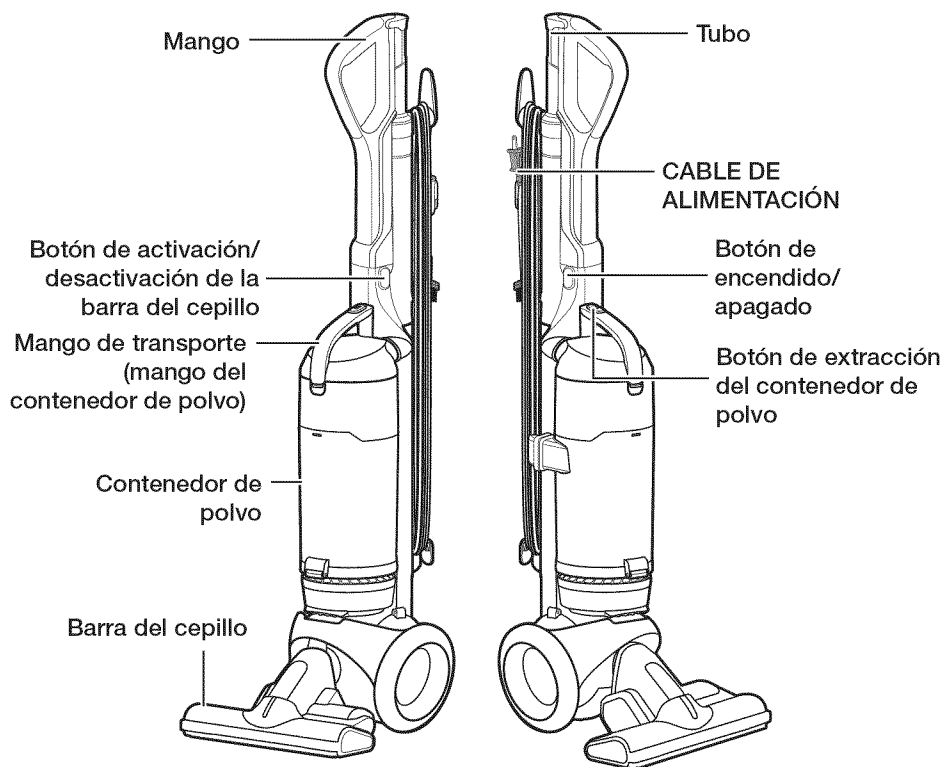

PRECAUCIÓN

No enchufe la aspiradora hasta que no esté familiarizado con las instrucciones y los procedimientos de funcionamiento.



ADVERTENCIA

La película de plástico puede resultar peligrosa. Para evitar riesgos de asfixia, mantenga la película lejos de bebés y niños.

## CONTENIDO DEL EMBALAJE

---

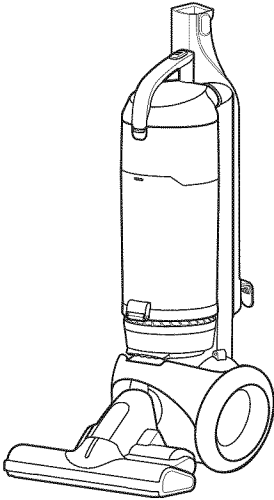

(1)

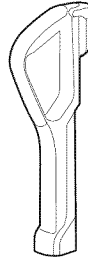

(2)

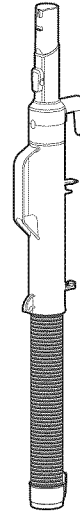

(3)



(4)

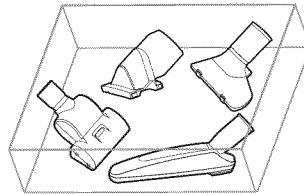

(5)



(6)

- Vacíe la caja. Compruebe que no falta ninguna de las piezas que se muestran antes de deshacerse de los materiales del embalaje.

1. Cuerpo de la aspiradora
2. Mango
3. Tubo
4. Accesorio 2 en 1
5. Kit de accesorios (opcional según el modelo)
6. Manual del usuario

# Antes de utilizar la aspiradora

## MONTAJE DEL MANGO Y DEL TUBO

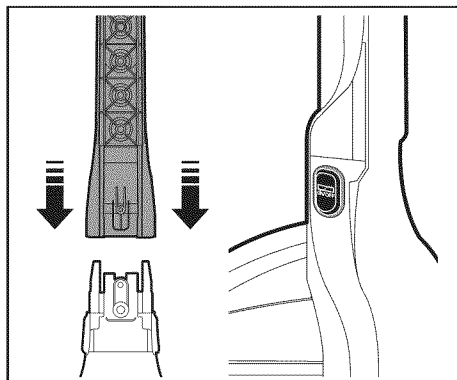

- Conecte el mango y el cuerpo.

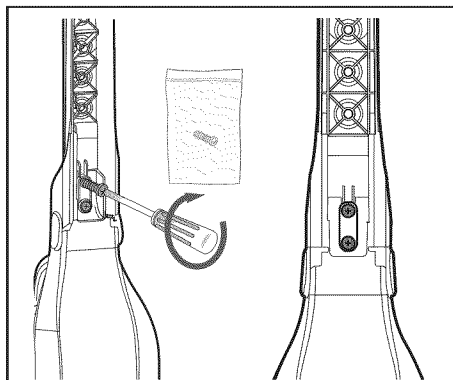

- Saque el tornillo de la bolsa y enrósquelo con un destornillador Phillips (+) como se muestra en la ilustración.

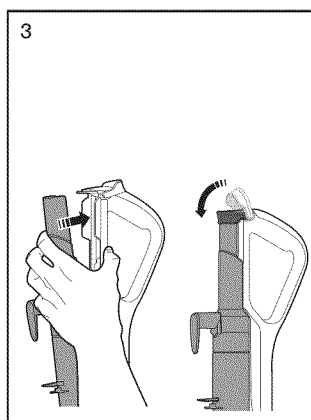
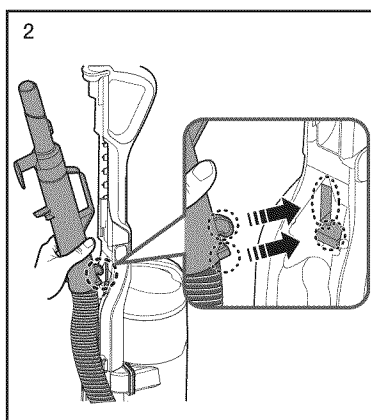
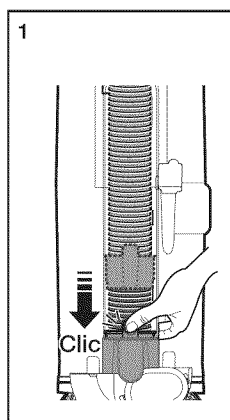

1. Mantenga la aspiradora vertical e inserte la parte inferior del tubo en el orificio del cuerpo hasta oír un clic.
2. Inserte el enganche de la parte superior del tubo en el orificio del mango como se muestra en la ilustración. El enganche debe empujar el botón azul celeste de la parte posterior del mango.
3. Monte la parte superior del tubo en el mango y cubra con la tapa.



- Enrolle el cable alrededor de los ganchos y asegúrelo con la grapa.

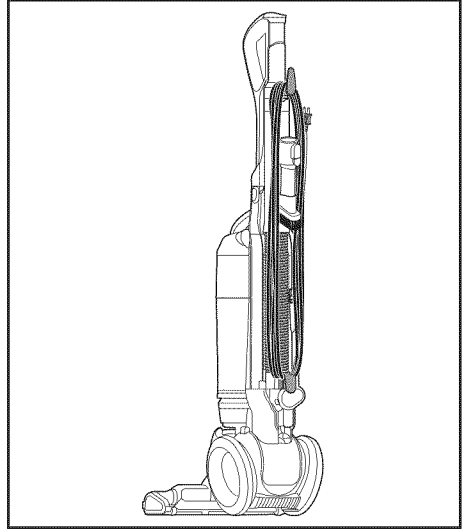

## MONTAJE DE LOS ACCESORIOS

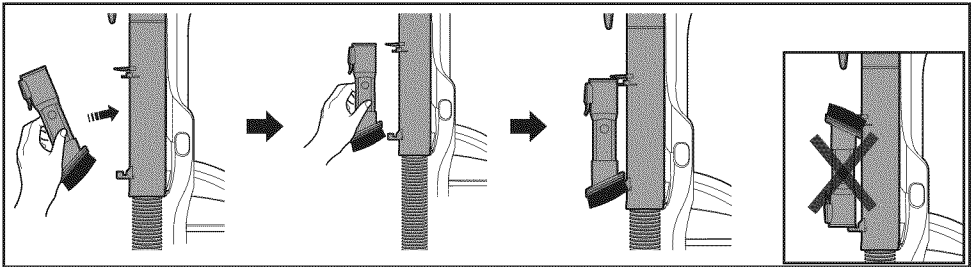

## USO DE LOS ACCESORIOS

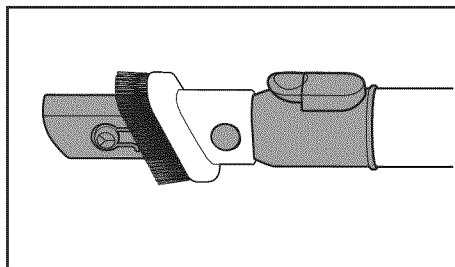
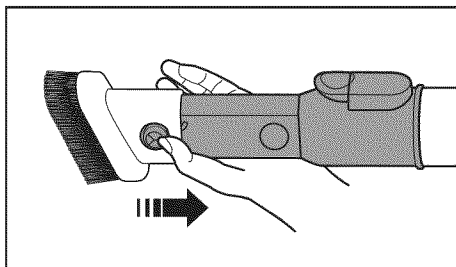

- Boquilla

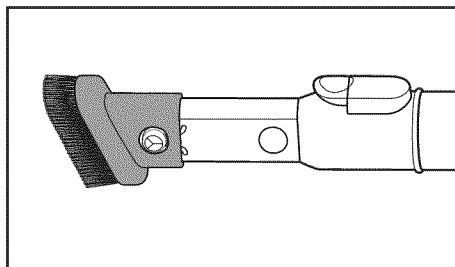
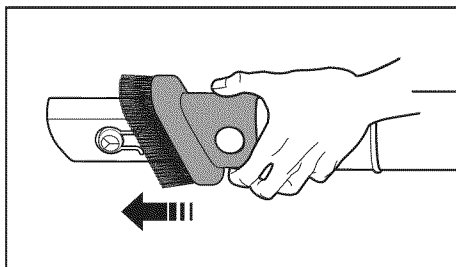

- Cepillo para polvo

# Funcionamiento de la aspiradora

## RECOGIDA DEL CABLE DE ALIMENTACIÓN

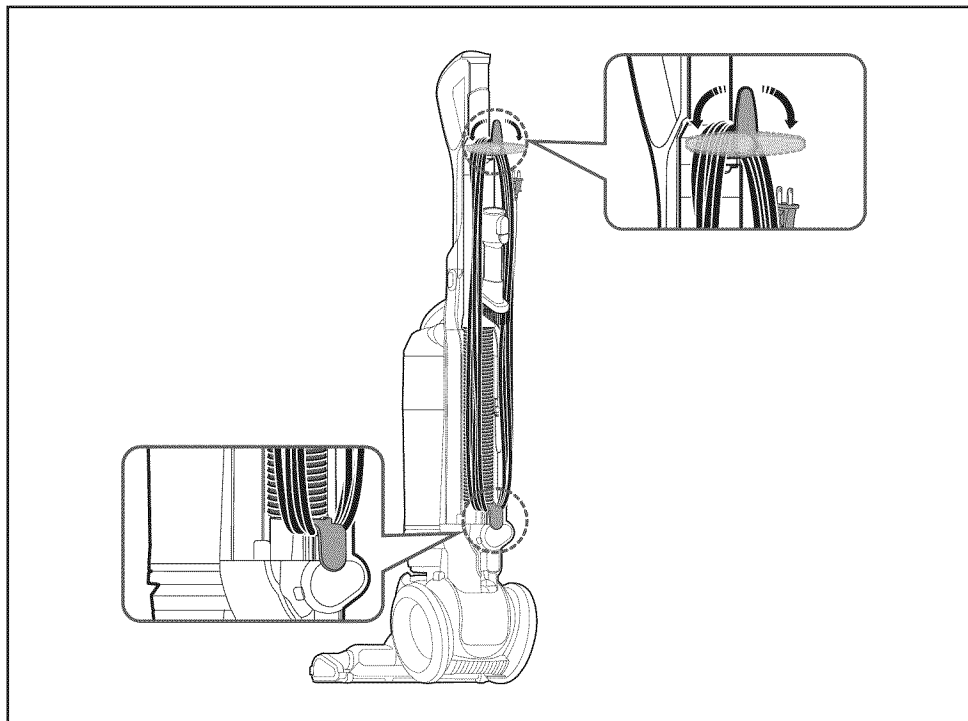

PRECAUCIÓN

Para desenchufar el aparato sujete el enchufe, no el cable.

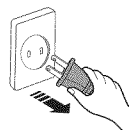

## ALARGAMIENTO DEL TUBO

### Modo de tubo

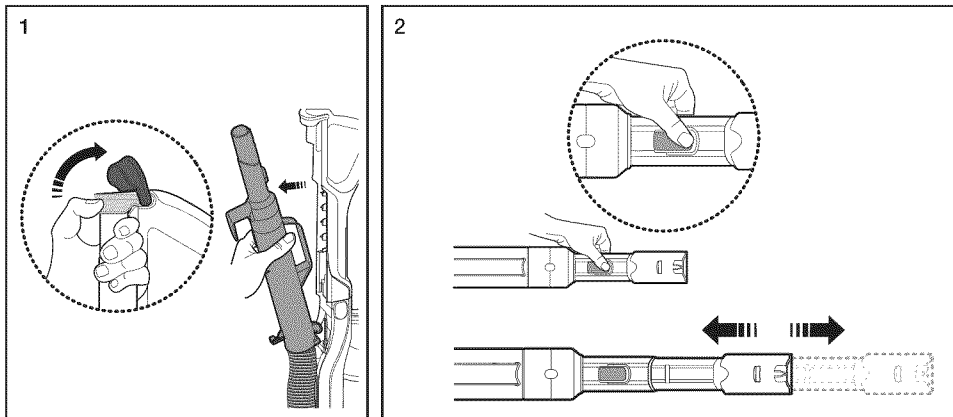

- Empuje la cubierta del mango hacia arriba y separe el tubo del cuerpo.
- Presione el botón del tubo para alargar este.

## USO DEL MODO VERTICAL

### Modo vertical

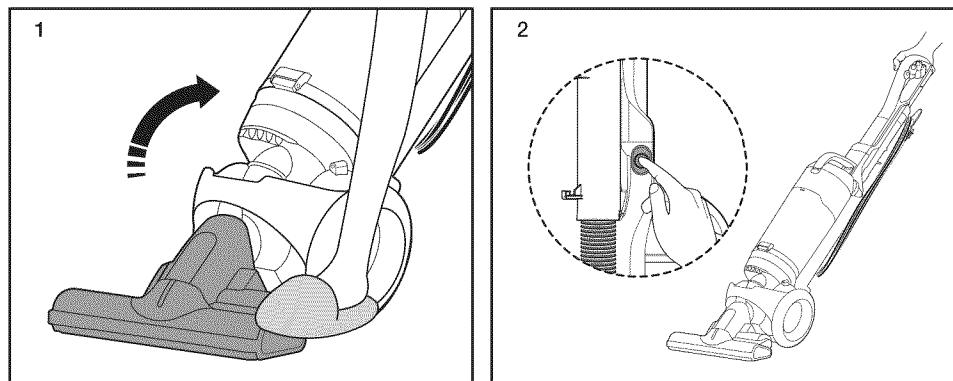

- Ponga un pie sobre el cepillo e incline suavemente el mango hacia atrás para liberar el bloqueo.
- Pulse el conmutador de encendido/apagado

## FUNCIONAMIENTO DEL CONMUTADOR DE ACTIVACIÓN/DESACTIVACIÓN DE LA BARRA DEL CEPILLO

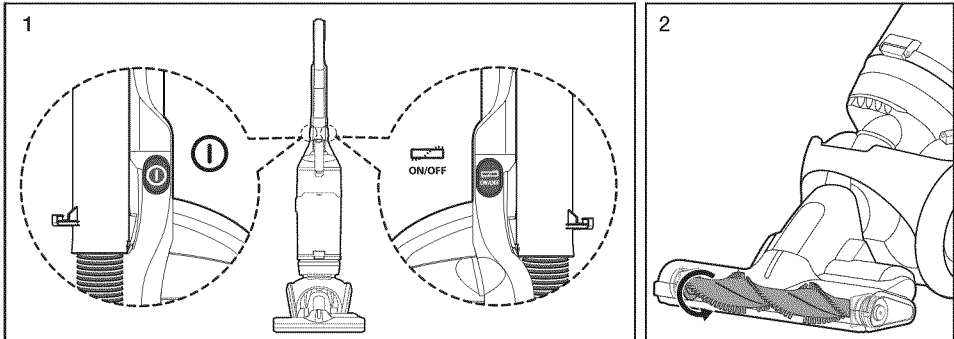

- Pulse el conmutador de encendido/apagado y, a continuación, el de activación/desactivación de la barra del cepillo.



En la posición vertical, la barra del cepillo no funciona.

## REINICIO DEL PROTECTOR CONTRA SOBRECARGA

- El protector contra sobrecarga apaga el motor del cepillo si la barra del cepillo se obstruye. Para reiniciar el protector contra sobrecarga, utilice la punta de un bolígrafo para presionar el conmutador de reinicio.

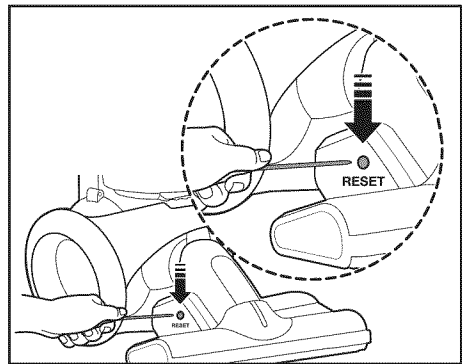

## USO DEL MANGO DE LA ASPIRADORA (MANGO DEL CONTENEDOR DE POLVO)

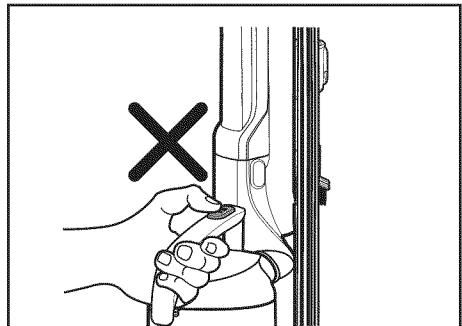
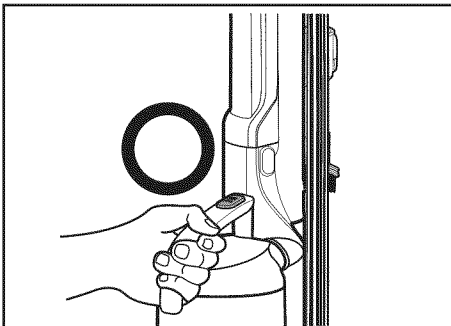

Cuando desplace la aspiradora sujetándola por el mango, no presione el botón de liberación del contenedor de polvo.

## USO DEL KIT DE ACCESORIOS (OPCIONAL)

### Accesorio para muebles

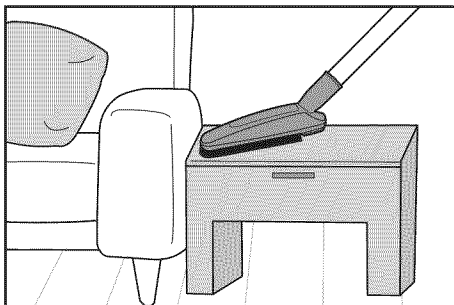
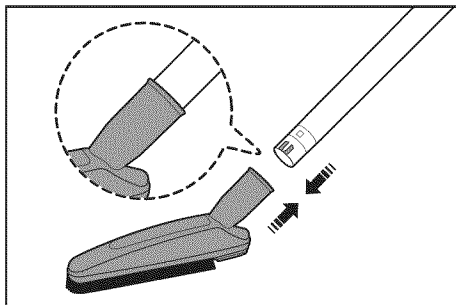

### Accesorio para tapicerías

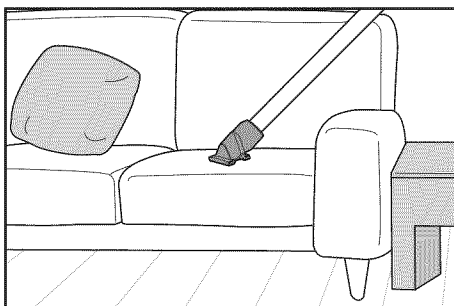
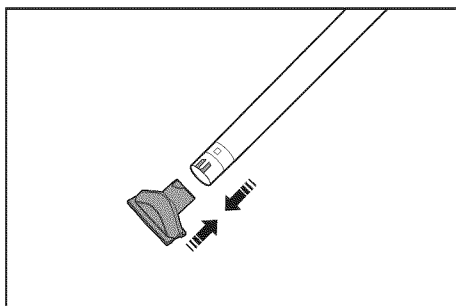

### Cepillo miniturbo

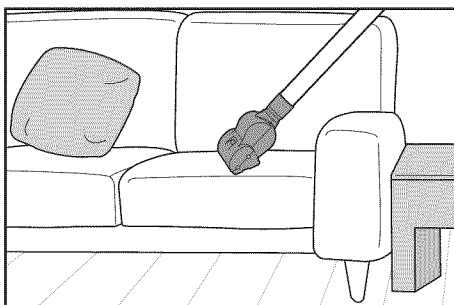
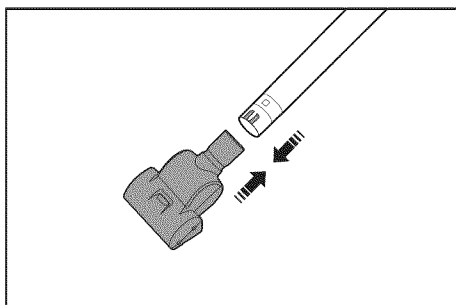

## Accesorio para mascotas

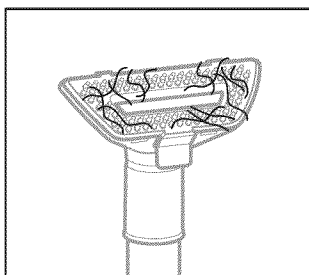
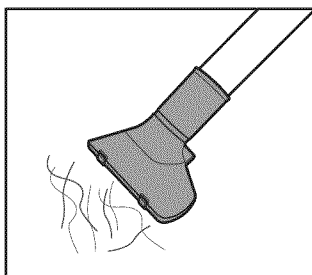
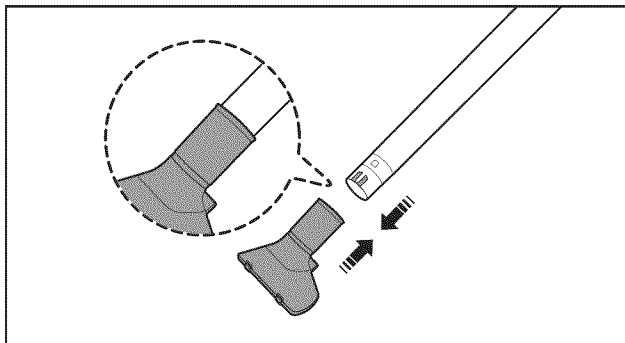

- Aspire los pelos.

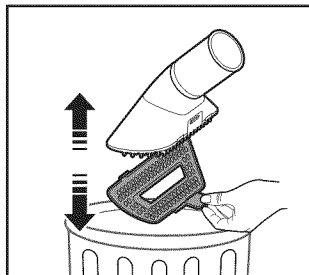
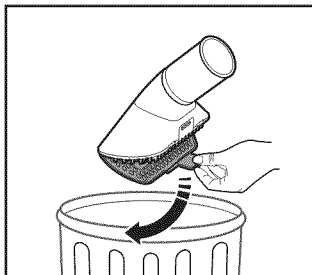

- Separe la cubierta del accesorio para mascotas y retire los pelos.

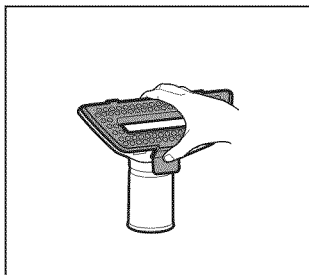
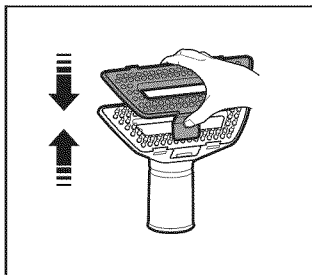

- Vuelva a montar la cubierta.

# Mantenimiento

## VACIADO DEL CONTENEDOR DE POLVO

- Vacíe el contenedor de polvo cuando el polvo llegue a la marca 'MAX'.
- Extraiga el contenedor de polvo presionando el botón del mango.

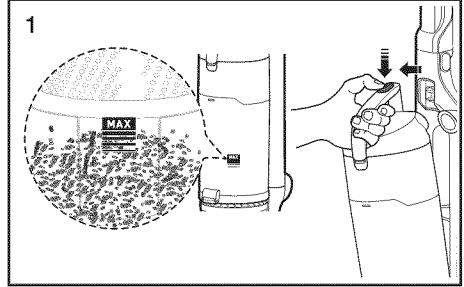

- Para vaciar el contenedor de polvo, sosténgalo sobre el cubo de la basura y presione el botón que hay cerca de la parte inferior del contenedor.

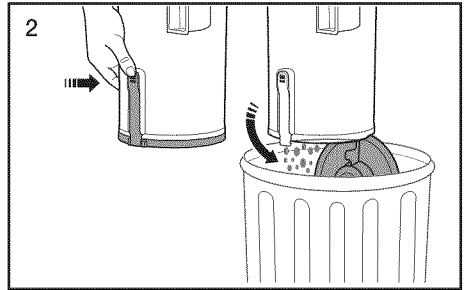

- Para vaciar el recipiente de la basura, coloque el mismo en una bolsa plástica, luego presione el botón en la parte inferior para liberar los residuos.  
(Recomendado para los enfermos de asma / alergia)

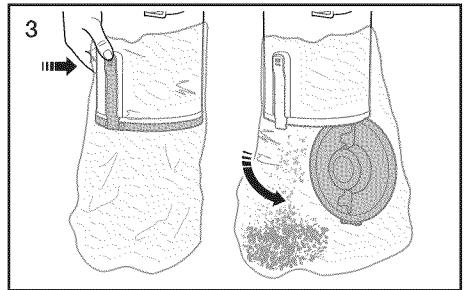

- Cierre la parte inferior del recipiente, y luego deje caer la bolsa de plástico en la basura.  
(Recomendado para los enfermos de asma / alergia)

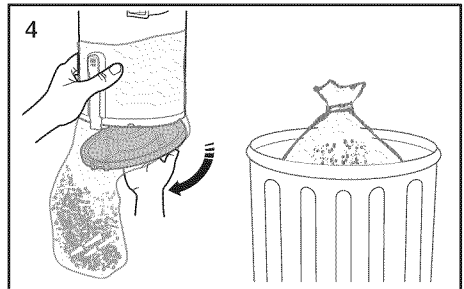



## LIMPIEZA DE LA REJILLA

- Separe el contenedor de polvo del cuerpo de la aspiradora.
- Limpie la rejilla con el cepillo para polvo para eliminar la pelusa.
- Para volver a montar el contenedor de polvo en el cuerpo de la aspiradora, siga los pasos 3 y 4.

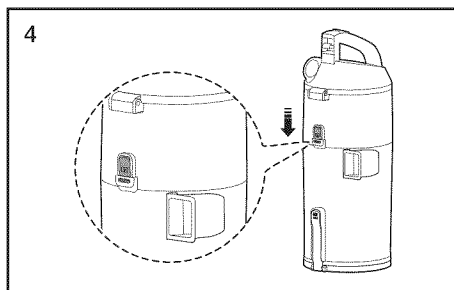
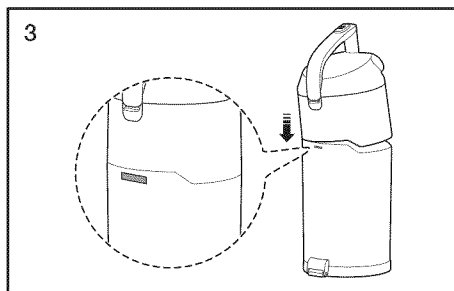
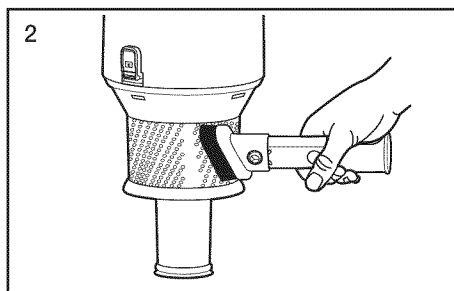
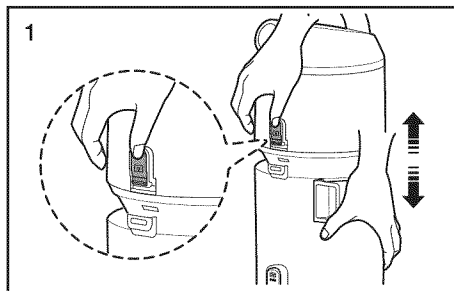

## LIMPIEZA DEL FILTRO PREMOTOR



- Tire de la cubierta del contenedor de polvo para abrirlo.

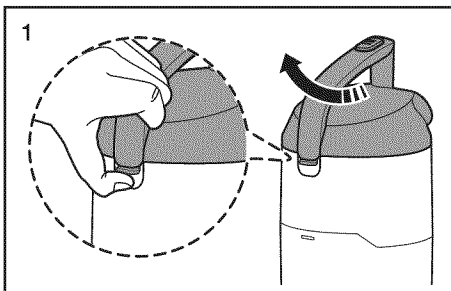

- Retire el filtro del contenedor de polvo.

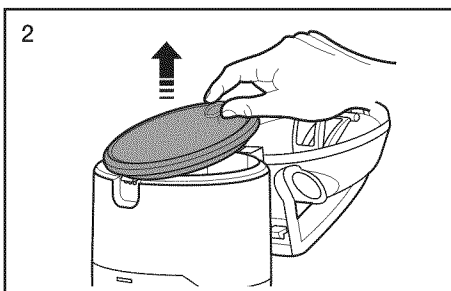

- Sacuda el filtro para eliminar el polvo y lave el filtro.

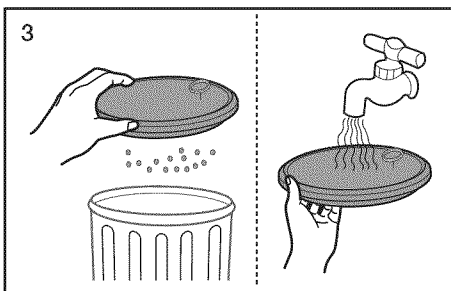

- Deje el filtro a la sombra hasta que se seque completamente.

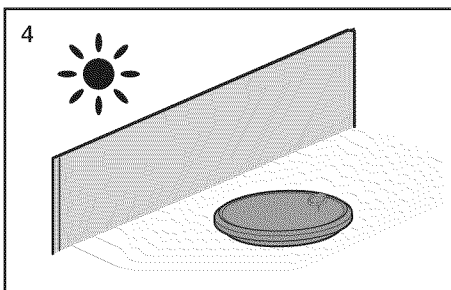

- Vuelva a montar el filtro en el contenedor de polvo.

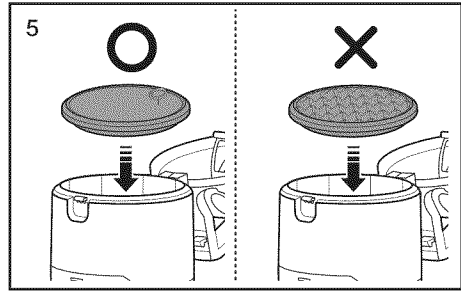

Revise el filtro con regularidad y lávelo cada 1 o 2 meses.

Compruebe que el filtro esté completamente seco antes de volver a colocarlo en la aspiradora. Déjelo secar durante 12 horas.

No utilice el filtro si está húmedo.

Sustituya el filtro de polvo si está dañado o deformado.

La cubierta del contenedor de polvo no se cerrará si el filtro no está bien instalado.



## LIMPIEZA DEL FILTRO HEPA



- Extraiga el contenedor de polvo presionando el botón del mango.

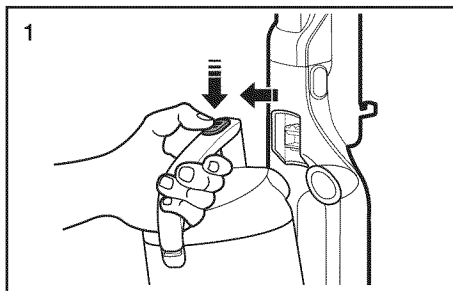

- Retire la cubierta del filtro.

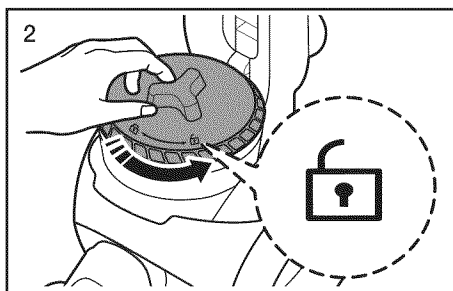

- Separe el filtro HEPA del cuerpo de la aspiradora.

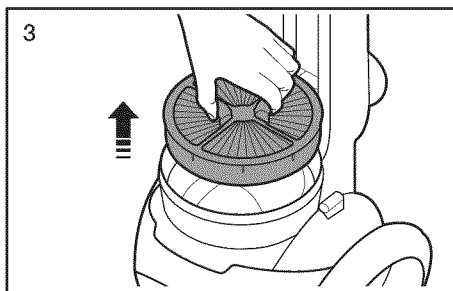

- Sacuda el filtro para eliminar el polvo.

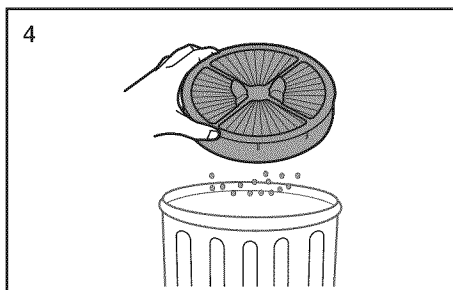

Limpie el filtro HEPA si se reduce notablemente la potencia de succión de manera continuada o si la aspiradora se sobrecalienta.

Nota: los filtros HEPA no son lavables.

Sustituya el filtro si limpiándolo no se resuelve el problema.

- Vuelva a insertar el filtro en el cuerpo de la aspiradora.

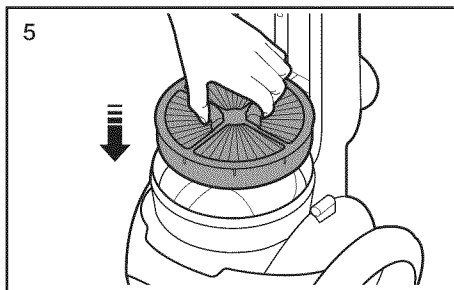

- Vuelva a montar el filtro y la cubierta de este.

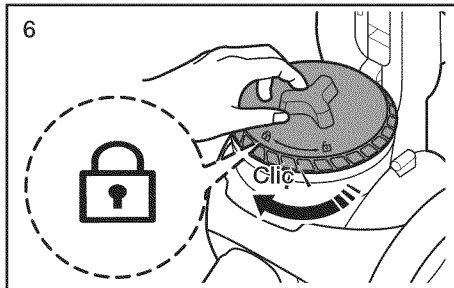

- Vuelva a montar el contenedor de polvo en la aspiradora.

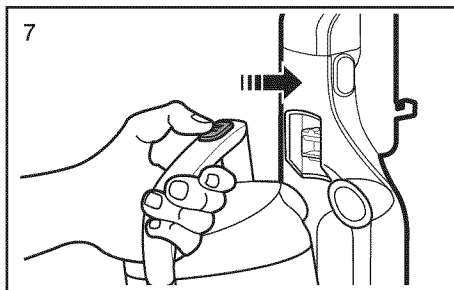

La cubierta del contenedor de polvo no se cerrará si el filtro no está bien instalado.

## COMPROBACIÓN DEL CEPILLO

- Apague y desenchufe la aspiradora. Incline la aspiradora para facilitar el acceso a la parte inferior, como se muestra en la ilustración.

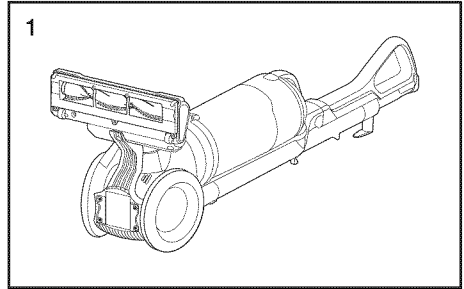

- Con cuidado corte los pelos o las hilachas atrapados en el cepillo.

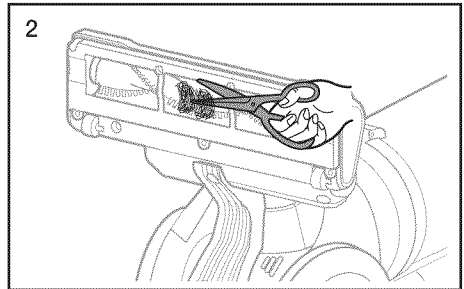

Antes de inspeccionar la barra del cepillo, desactívela y desenchufe la aspiradora.

## COMPROBACIÓN DE OBSTRUCCIONES

- Ponga un pie sobre el cepillo e incline suavemente el mango hacia atrás para liberar el bloqueo.

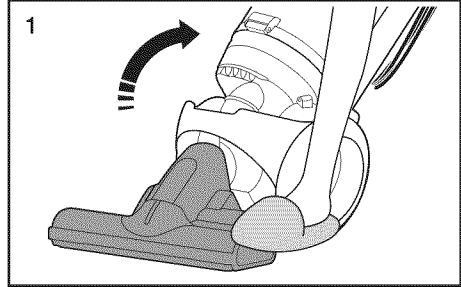

- Presione el botón de liberación de la carcasa del cepillo y extraiga la manguera.

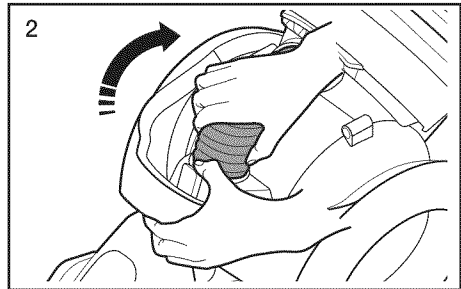

- Examine si la abertura de la carcasa del cepillo y la manguera están obstruidas.

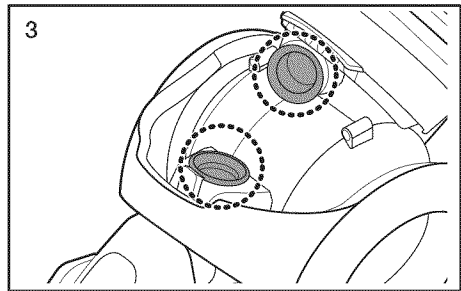

- A continuación, vuelva a montar la manguera y la carcasa del cepillo



Antes de examinar si hay obstrucciones, desactive la barra del cepillo y desenchufe la aspiradora.

## CEPILLO MINITURBO (OPCIONAL)

### INSPECCIÓN DEL RODILLO DEL CEPILLO

- Si hay obstrucciones o restos de suciedad visibles, inspeccione el rodillo del cepillo.

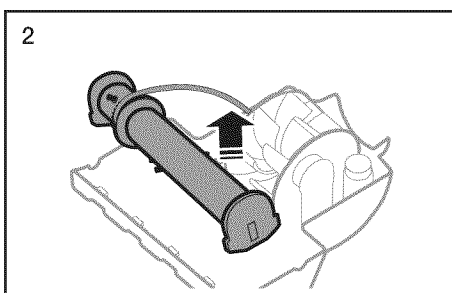
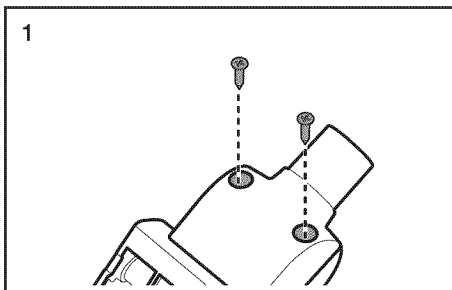

### INSPECCIÓN DE LA CORREA

- Si la correa está rota o agrietada, reemplázela por una nueva siguiendo las ilustraciones de la derecha.

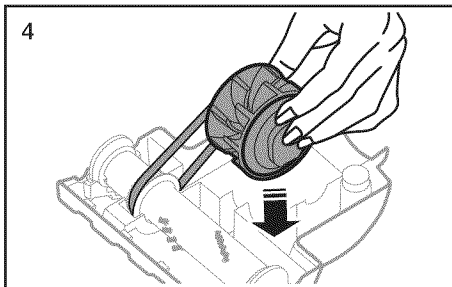
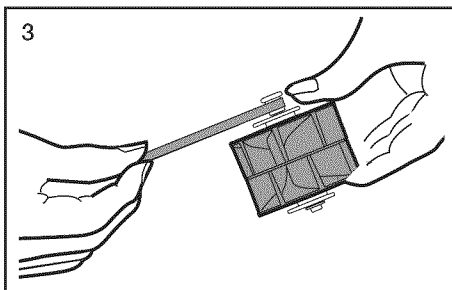



## LIMPIEZA DE LA CUBIERTA DEL DESVIADOR

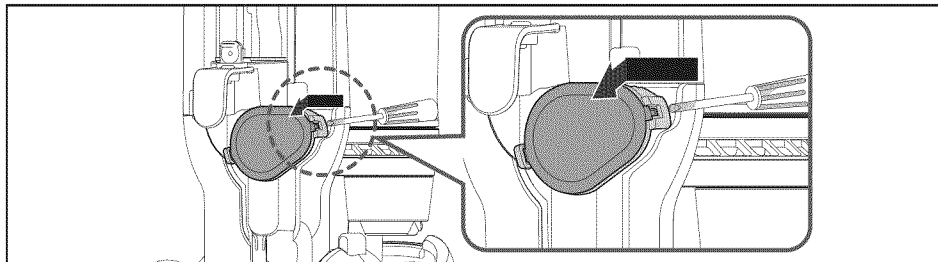

- Abra la cubierta del desviador con un destornillador de punta plana (-).

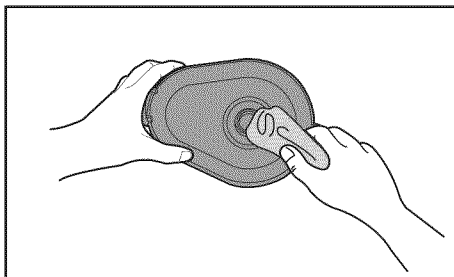
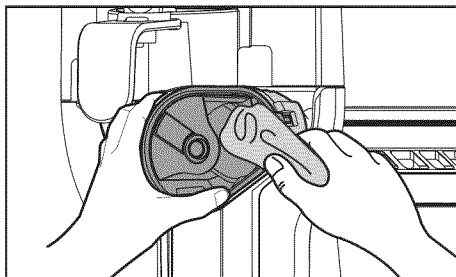

- Limpie el interior de la cubierta con un paño seco.

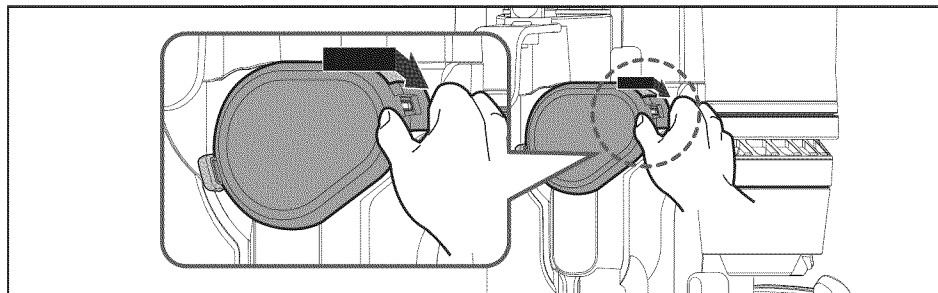
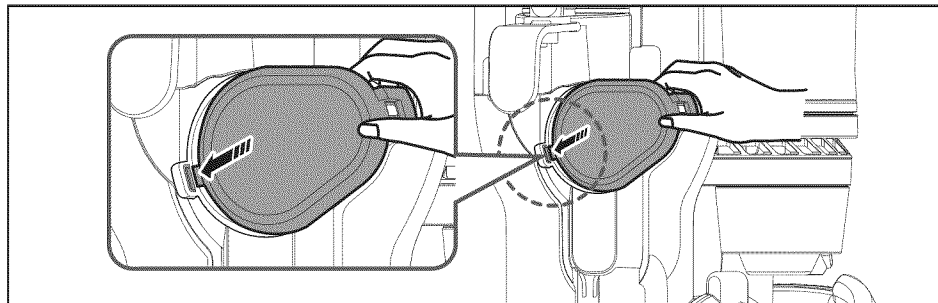

- Vuelva a montar la cubierta después de limpiarla.

# Solución de problemas

Compruebe esta lista de problemas y posibles soluciones antes de llevar la aspiradora a un centro de servicio técnico.

<b>PROBLEMA</b>	<b>SOLUCIÓN</b>
<b>La aspiradora no funciona.</b>	<ul style="list-style-type: none"><li>• Compruebe el enchufe. Asegúrese de que esté bien conectado.</li><li>• Pulse el botón de encendido/apagado.</li><li>• Reinicie el protector contra sobrecarga.</li></ul>
<b>El motor de succión no arranca. Activado el protector térmico.</b>	<ul style="list-style-type: none"><li>• Deje enfriar la aspiradora.</li></ul>
<b>El motor del cepillo no arranca.</b>	<ul style="list-style-type: none"><li>• Compruebe el botón [BRUSH ON/OFF (ACTIVAR/DESACTIVAR CEPILLO)].</li><li>• Retire los pelos e hilachas del cepillo.</li><li>• Reinicie el protector contra sobrecarga.</li></ul>
<b>La aspiradora no aspira o la fuerza de succión es baja.</b>	<ul style="list-style-type: none"><li>• Vacíe el contenedor de polvo.</li><li>• Limpie el filtro y asegúrese de que el conjunto del filtro esté posicionado correctamente.</li><li>• Compruebe la conexión de la manguera o la dirección del flujo.</li></ul>
<b>Sale polvo de la aspiradora.</b>	<ul style="list-style-type: none"><li>• Vacíe el contenedor de polvo.</li><li>• Limpie los filtros premotor.</li><li>• Limpie o cambie el filtro de salida (Filtro HEPA).</li><li>• Compruebe que el conjunto del filtro esté posicionado correctamente.</li></ul>
<b>Los accesorios de limpieza no aspiran.</b>	<ul style="list-style-type: none"><li>• Compruebe si hay obstrucciones en las entradas, la manguera y el contenedor de polvo. Retire las obstrucciones.</li><li>• Vacíe el contenedor de polvo.</li><li>• Retire y limpie los filtros.</li><li>• Asegúrese de que el contenedor de polvo está correctamente bloqueado.</li></ul>
<b>El botón azul celeste no recupera su posición después de haberlo presionado.</b>	<ul style="list-style-type: none"><li>• Revise el desviador.</li><li>• Limpie la cubierta y el interior del desviador.</li></ul>

# comentarios

---



Si tiene preguntas o comentarios relacionados con los productos Samsung, póngase en contacto con el centro de asistencia al cliente SAMSUNG.

PAÍS	CENTRO DE ATENCIÓN AL CLIENTE	SITIO WEB
EE.UU.	1-800-SAMSUNG	<a href="http://www.samsung.com">www.samsung.com</a>
CANADÁ	1-800-SAMSUNG (726-7864)	<a href="http://www.samsung.com">www.samsung.com</a>



DJ68-00709B-00