

BLADEZ[®]
FITNESS

ST7i



OWNER'S MANUAL

Important: Read all instructions carefully before using this product. Retain this owner's manual for future reference.

BH North America | 20155 Ellipse, Foothill Ranch, California 92610 | p.949.206.0330 | f.949.206.0013 | www.bhnorthamerica.com

BLADEZ®

F I T N E S S

TABLE OF CONTENTS

Title	Page
Introduction	03
Safety Information	04
Exercise Instruction	05
Training Guidelines	06
Suggested Stretches	10
Assembly Instructions	12
Console Operations	17
Maintenance and Cleaning	27
Exploded View Drawing	28
Parts List	29
Warranty	30

CONGRATULATIONS

Congratulations on your purchase of Bladez Fitness equipment. We hope you appreciate the style, quality, and value that exercisers around the world have come to expect from Bladez Fitness.

If you have any questions, concerns or product issues please call our Customer Service Team at 1-866-325-2339 or email us at CustomerSupport@BHNorthAmerica.com.

Carefully read through the instructions contained in this manual. They provide you with important information about assembly, safety, fitness and use of the machine. Please read ALL the safety information contained on the following page.

SAFETY INFORMATION

PRECAUTIONS

This equipment has been designed and constructed to provide maximum safety. Nevertheless, certain precautions should be taken when using exercise equipment. Read the whole manual before assembling and using the machine. Please observe the following safety precautions:

1. Keep children and pets away from this equipment at all times. DO NOT leave them unsupervised in the room where the machine is kept.
2. If you experience dizziness, nausea, chest pains or any other symptom while using this machine STOP the exercise. SEEK IMMEDIATE MEDICAL ATTENTION!
3. Use the machine on a level and solid surface. Adjust the feet for stability.
4. Keep your hands away from any of the joints and moving parts.
5. Wear clothing suitable for doing exercise. Do not wear baggy clothing that might get caught in the machine. Always wear athletic shoes when using the machine and tie the laces securely.
6. This machine must only be used for the purposes described in this manual. DO NOT use accessories that are not recommended by Bladez Fitness. Read manual prior to use and follow all warnings and instructions.
7. Do not place sharp objects near the machine.
8. Any person with physical or coordination limitations should not use the machine without the assistance of a qualified person or doctor. Misuse of this machine may result in serious injury.
9. Do warm-up stretching exercises before using the equipment.
10. Do not use the machine if it is not working correctly.
11. Before using the machine, thoroughly inspect the equipment for proper assembly.
12. Keep a perimeter of 3 feet (1 meter) around the machine before operating the equipment.
13. Use only authorized and trained technicians if a repair is needed.
14. Please follow the advice for correct training, as detailed in the Training Guidelines.
15. Use only the tools provided to assemble this machine.
16. Replace warning labels if damaged, illegible or removed.
17. This machine was designed for a maximum user weight of 325 lbs (147.5 kg)
18. The machine can only be used by one person at a time.

Caution: Consult your doctor before beginning to use the machine or any exercise program. Read all of the instructions before using any exercise equipment.

KEEP THESE INSTRUCTIONS SAFE FOR FUTURE USE.

EXERCISE INSTRUCTION

Use of the machine offers various benefits; it can improve fitness, muscle tone and when used in conjunction with a calorie controlled diet, it can help you lose weight.

1. Consult your doctor before starting any exercise program. It is advisable to undergo a complete physical examination.
2. Work at the recommended exercise level. Do not over exert yourself.
3. If you feel any pain or discomfort, stop exercising immediately and consult your doctor.
4. Wear appropriate clothing and footwear for the exercise; do not wear loose clothing; do not wear leather soled shoes or footwear with high heels.
5. It is advised that you do warm-up stretches before working out.
6. Get on the equipment slowly and securely.
7. Select the program or workout option that is most closely aligned with your workout interests.
8. Start slowly and work your way up to a comfortable pace.
9. Be sure to cool down after your workout.

TRAINING GUIDELINES

Exercise is one of the most important factors in the overall health of an individual. Listed among its benefits are:

- Increased capacity for physical work (strength endurance)
- Increased cardiovascular (heart and arteries/veins) and respiratory efficiency
- Decreased risk of coronary heart disease
- Changes in body metabolism, e.g. losing weight
- Delaying the physiological effects of age
- Reduction in stress, increase in self-confidence, etc.

There are several components of physical fitness and each is defined below.

STRENGTH

The capacity of a muscle to exert a force against resistance. Strength contributes to power and speed.

MUSCULAR ENDURANCE

The capacity to exert a force repeatedly over a period of time, e.g. it is the muscular endurance of your legs to carry you 10 km without stopping.

FLEXIBILITY

The range of motion of your joints. Improving flexibility involves the stretching of muscles and tendons to maintain or increase suppleness, and it provides increased resistance to muscle injury or soreness.

CARDIO-RESPIRATORY ENDURANCE

The most essential component of physical fitness. It is the efficient functioning of the heart and lungs.

AEROBIC FITNESS

Is an exercise of relatively low intensity and long duration, which depends primarily on the aerobic energy system. Aerobic means "with oxygen", and refers to the use of oxygen in the body's metabolic or energy-generating process. Many types of exercise are aerobic, and by definition are performed at moderate levels of intensity for extended periods of time.

ANAEROBIC TRAINING

Is an exercise intense enough to trigger anaerobic metabolism. This means "without oxygen" and is the output of energy when the oxygen supply is insufficient to meet the body's long term energy demands. (For example, a 100 meter sprint.)

OXYGEN UPTAKE

The effort that you can exert over a prolonged period of time is limited by your ability to deliver oxygen to the working muscles. Regular vigorous exercise produces a training effect that can increase your aerobic capacity by as much as 20 to 30%. An increased VO₂ Max indicates an increased ability of the heart to pump blood, of the lungs to ventilate oxygen, and of the muscles to take up oxygen.

THE TRAINING THRESHOLD

This is the minimum level of exercise which is required to produce significant improvements in any physical fitness parameter.

OVERLOAD

This is where you exercise above your comfort level. The intensity, duration and frequency of exercise should be above the training threshold and should be gradually increased as the body adapts to the increasing demands. As your fitness level improves, the training threshold should rise. Working through your program and gradually increasing the overload factor is important.

PROGRESSION

As you become more fit, a higher intensity of exercise is required to create an overload and therefore provide continued improvement.

SPECIFICS

Different forms of exercise produce different results. The type of exercise that is carried out is specific to the muscle groups being used and to the energy source involved. There is little transfer of the effects of exercise, i.e. from strength training to cardiovascular fitness. That is why it is important to have an exercise program tailored to your specific needs.

REVERSIBILITY

If you stop exercising or do not do your program often enough, you will lose the benefits you have gained. Regular workouts are the key to success.

WARM-UP

Every exercise program should start with a warm-up where the body is prepared for the effort to come. It should be gentle and preferably use the muscles group to be involved later. Stretching should be included in both your warm-up and cool down, and should be performed after 3-5 minutes of low intensity aerobic activity or calisthenic type exercise.

WARM DOWN OR COOL DOWN

This involves a gradual decrease in the intensity of the exercise session. Following exercise, a large supply of blood remains in the working muscles. If it is not returned promptly to the central circulation, pooling of blood may occur in the muscles.

HEART RATE

As you exercise, your heart beat increases. This is often used as a measure of the required intensity of an exercise. You need to exercise hard enough to condition your circulatory system, and increase your pulse rate, but not enough to strain your heart.

Your initial level of fitness is important when developing an exercise program for you. When starting, you can get a good training effect with a heart rate of 110-120 beats per minute (BPM). If you are more fit, you will need a higher threshold of stimulation.

To begin with, you should exercise at a level that elevates your heart rate to about 65 to 70% of your maximum. If you find this is too easy, you may want to increase it, but it is better to lean on the conservative side.

As a rule of thumb, the maximum heart rate is 220 minus your age. As you increase in age, your heart, like other muscles, loses some of its efficiency. Some of its natural loss is won back as fitness improves. The following table is a guide to those who are “starting fitness.”

Age Target Heart Rate	25	30	35	40	45	50	55	60	65
10 Second Count	23	22	22	21	20	19	19	18	18
Beats per Minute	138	132	132	126	120	114	114	108	108

PULSE COUNT

The pulse count (on your wrist or carotid artery in the neck, taken with two index fingers) is done for ten seconds, taken a few seconds after you stop exercising. This is for two reasons: (a) 10 seconds is long enough for accuracy, (b) the pulse count is to approximate your BPM rate at the time you are exercising. Since heart rate slows as you recover, a longer count isn't as accurate.

The target is not a magic number, but a general guide. If you're above average with your fitness, you may work comfortably a little above that suggested for your age group. The following table is a guide.

Age Target Heart Rate	25	30	35	40	45	50	55	60	65
10 Second Count	26	26	25	24	23	22	22	21	20
Beats per Minute	156	156	150	144	138	132	132	126	120

Don't push yourself too hard to reach the figures on this table. It can be very uncomfortable if you over exercise. Let it happen naturally as you work through your program. Remember, the target is a guide, not a rule, a little above or below is just fine.

Two final comments: (1) don't be concerned with day to day variations in your pulse rate, being under pressure or not enough sleep can affect it; (2) your pulse rate is a guide, don't become a slave to it.

MUSCLE SORENESS

For the first week or so, muscle soreness may be the only indication you have that you are on an exercise program. This, of course, does depend on your overall fitness level. A confirmation that you are on the correct program is a very slight soreness in most major muscle groups. This is quite normal and will disappear in a matter of days.

If you experience major discomfort, you may be on a program that is too advanced, or you have increased your program too rapidly.

If you experience PAIN during or after exercise, your body is telling you something. Stop exercising and consult your doctor.

WHAT TO WEAR

Wear clothing that will not restrict your movement in any way while exercising. Clothes should be light enough to allow the body to cool. Excessive clothing that causes you to perspire more than you normally would gives you no advantage. The extra weight you lose is body fluid and will be replaced with the next glass of water you drink. Always wear a pair athletic shoes.

BREATHING DURING EXERCISE

Do not hold your breath while exercising. Breathe normally as much as possible. Remember, breathing involves the intake and distribution of oxygen, which feeds the working muscles.

REST PERIODS

Once you start your exercise program, you should continue through to the end. Do not break off halfway through and then restart at the same place later on without going through the warm-up stage again. The rest period required between exercises may vary from person to person.

SUGGESTED STRETCHES

Head Rolls

Rotate your head to the right for one count while feeling the stretch up the left side of your neck. Next, rotate your head back for one count, stretching your chin to the ceiling. Rotate your head to the left for one count, and finally, drop your head to your chest for one count.

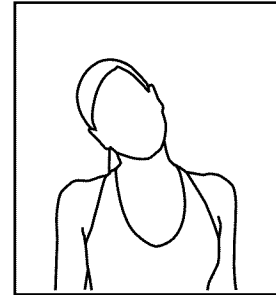

Shoulder Lifts

Lift your left shoulder up toward your ear for one count. Then lift your right shoulder up for one count as you lower your left shoulder.

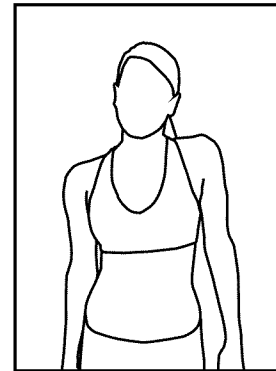

Side Stretches

Open your arms to the side and continue lifting them until they are over your head. Reach your left arm as far upward as you can for one count. Feel the stretch up your left side. Repeat this action with your right arm.

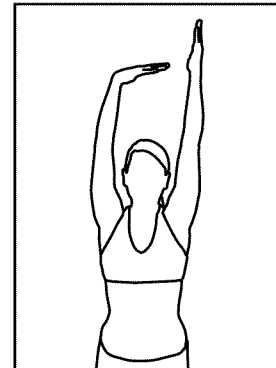

Quadriceps Stretch

With one hand against a wall for balance, reach behind you and pull your left foot up. Bring your heel as close to your buttocks as possible. Hold for 15 counts and repeat with right foot up.

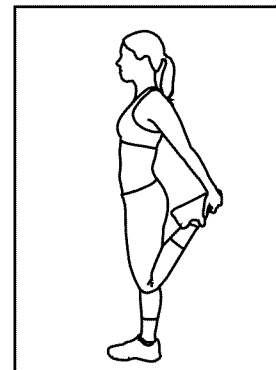

SUGGESTED STRETCHES

Inner Thigh Stretch

Sit with the soles of your feet together with your knees pointing outward. Pull your feet as close into your groin as possible. Gently push your knees towards the floor. Hold for 15 counts.

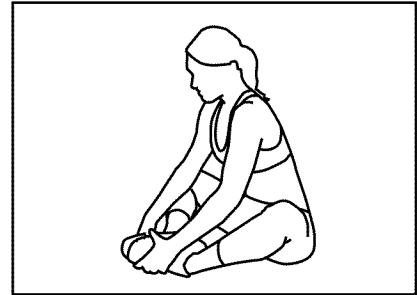

Toe Touches

Slowly bend forward from your waist, letting your back and shoulders relax as you stretch toward your toes. Reach down as far as you can and hold for 15 counts.

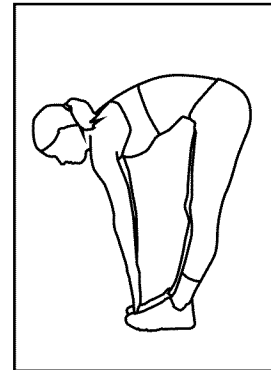

Hamstring Stretches

Sit with your right leg extended. Rest the soles of your left foot against your right inner thigh. Stretch toward your toes as far as possible. Hold for 15 counts. Relax and then repeat with left leg extended.

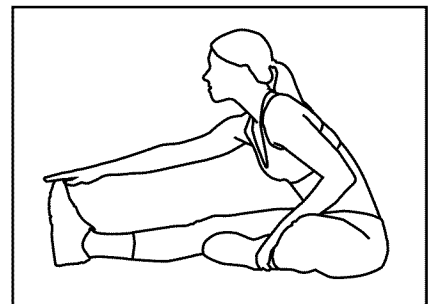

Calf/Achilles Stretches

Lean against a wall with your right leg in front of the left and your arms forward. Keep your left leg straight and the right foot on the floor; then bend the right leg and lean forward by moving your hip toward the wall. Hold, then repeat on the other side for 15 counts.

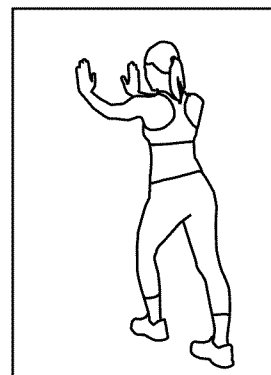

ASSEMBLY INSTRUCTIONS

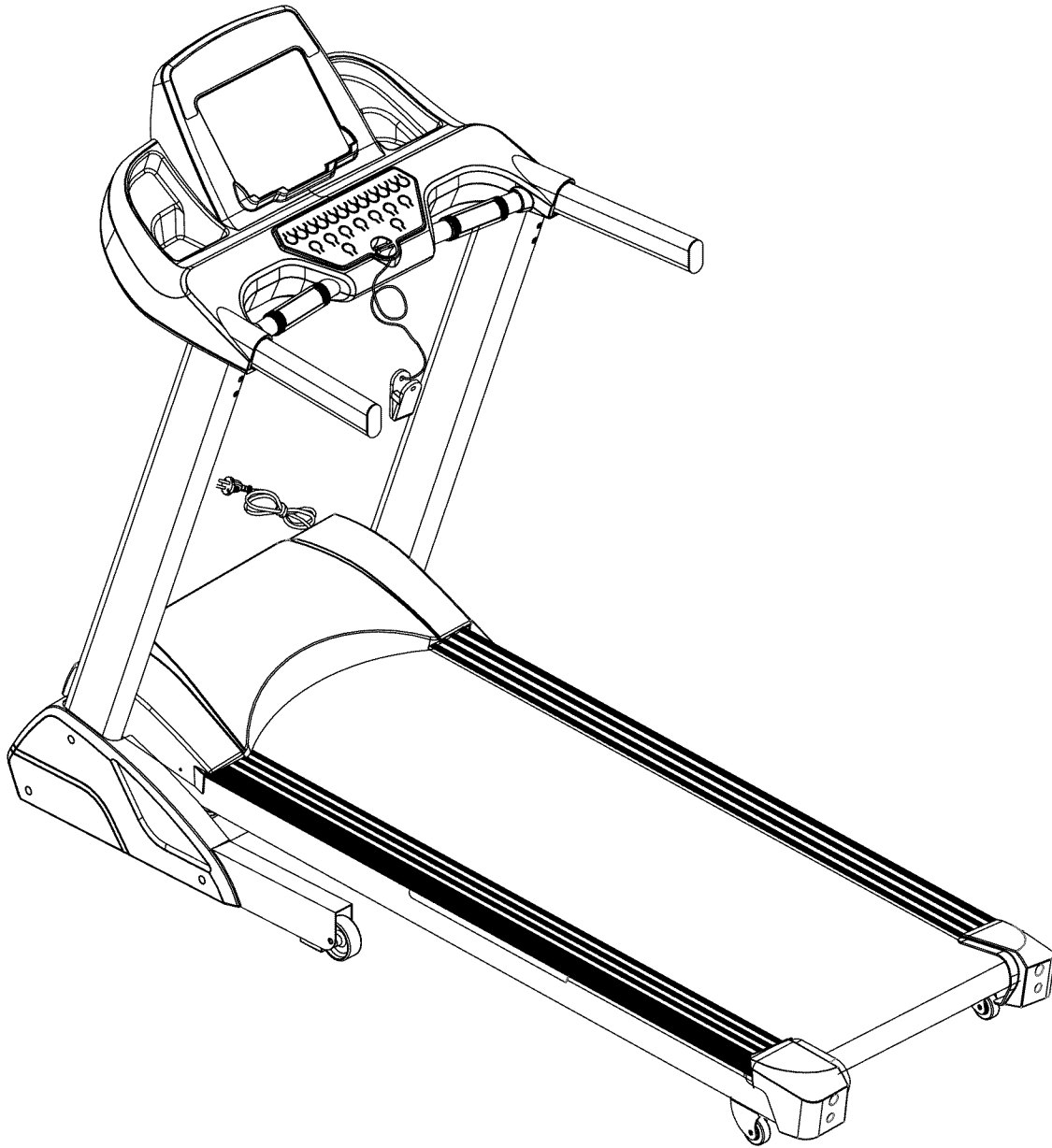

The assembly of this product requires two people.

Warning: Do not untie the packing strap until assembly is finished. Packing strap keeps product from folding.

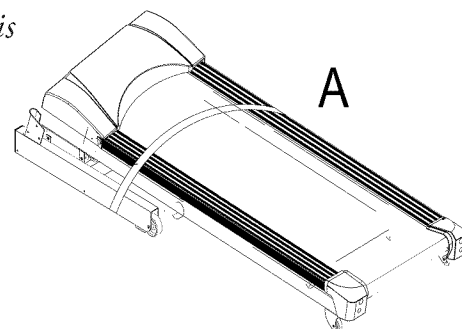

STEP 1

Install the Left Upright (C) and Right Upright (D) on the Base of the treadmill, Tighten with the Hex Screw (a). At this point, you may untie the packing strap.

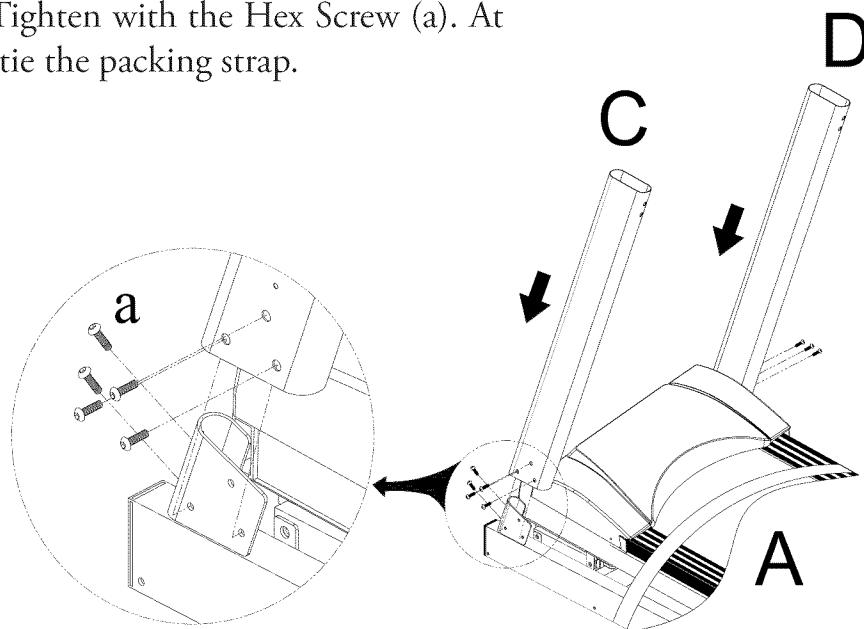

STEP 2

Please attached the Left (E) and Right (F) Decoration Cover with Screw (b).

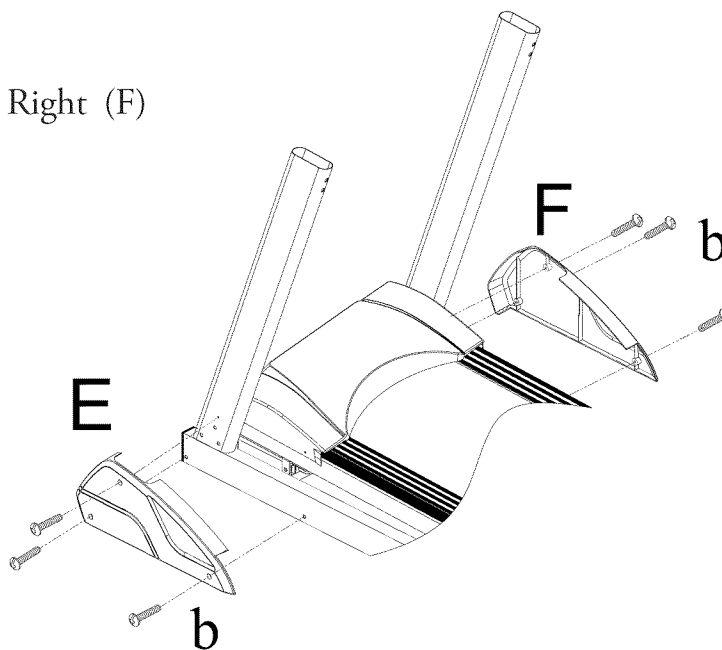

STEP 3

Attach the Computer Console (B) on the Left and Right Upright (C, D) and tighten with hex screw (a).

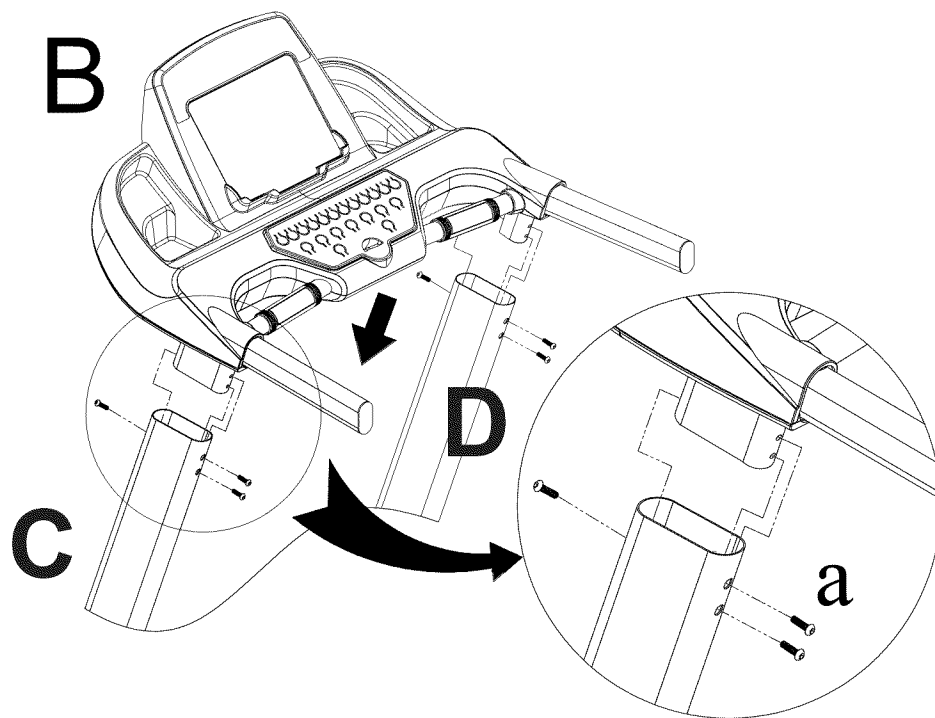

CAUTION

Note: The folding cylinder contains high pressure gas. Do not hit or damage this section, or it could cause the treadmill to unfold improperly or cause it to fall with out slowing down.

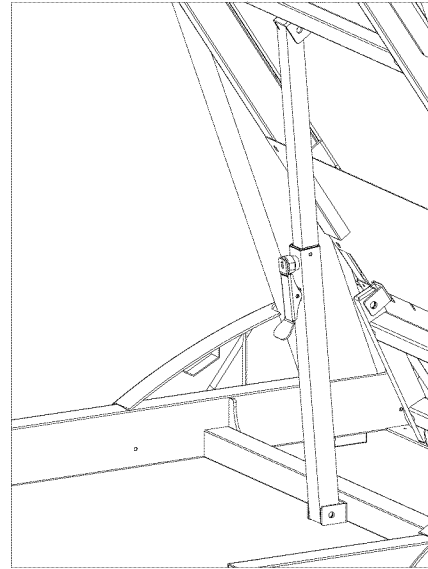

This treadmill folds for your convenience. Please turn the machine off and unplug it from the wall before folding. When the running belt is folded properly, you will here a click, the product is now secure.

To move the treadmill, grasp the endcaps at the end of the treadmill deck and lean the machine downward until you can smoothly roll the treadmill.

Do not move the treadmill on an uneven surface.

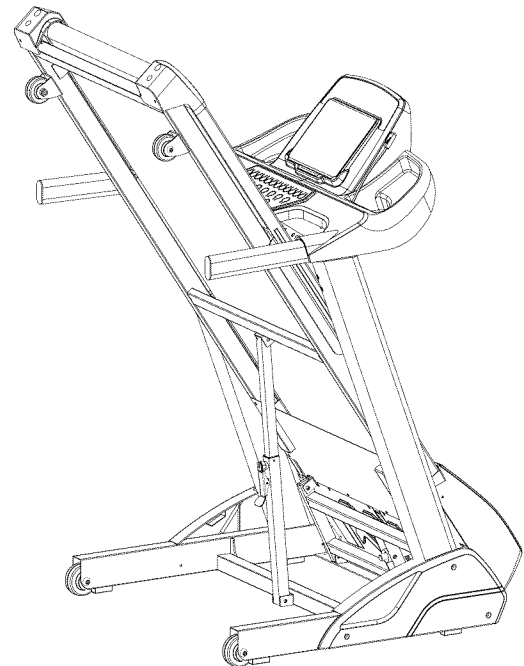

MAINTENANCE

To adjust the running belt, stop the treadmill, then use the Hex Wrench and adjust the Hex Screw located in the Rear End Cap. If the running belt is moving towards the left side, tighten the left Hex Screw about 1/4 turn (clockwise); if the running belt is moving towards the right side, tighten the right Hex Screw about 1/4 turn (clockwise); Turn the treadmill on after it has been adjusted. If you find that the belt has not moved to the proper position, please repeat the steps above. Don't use the treadmill until the running belt returns to the center position.

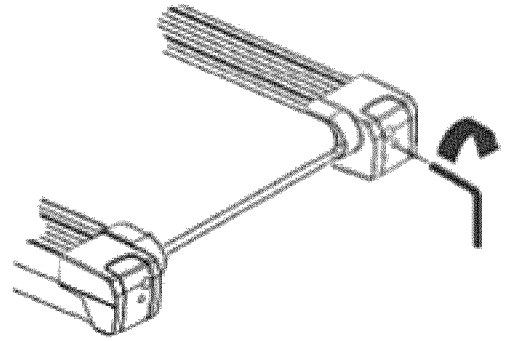

The position of running belt might not stay precisely in the center, it can and will shift slightly towards the left and right sides, however, you do not need to adjust the belt if it is not rubbing against the side rails.

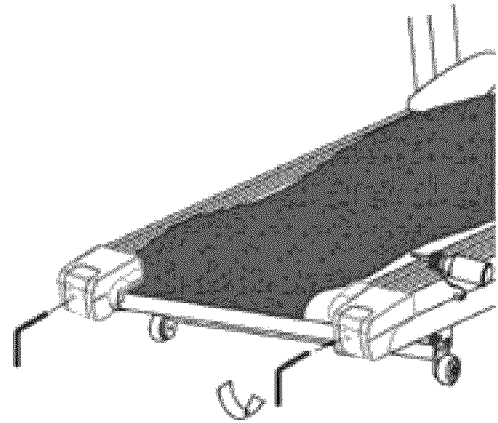

Depending on the usage of the product, please apply silicon according to the chart to the right. Use the Hex Wrench to unscrew the bolt inside the Rear Roller. Then pull the belt up and put some silicon to the center of the board. After that, adjust the belt to the center of the deck, followed by tightening the screw to the original set.

Silicon Chart

KGS/LBS	Speed	Interval
KGS	6KM/hr Below	1 year
	6~12KM/hr	6 months
	12KM/hr Above	3 months
LBS	4mile/hr Below	1 year
	4~8mile/hr	6 months
	8mile/hr Above	3 months

Note: This maintenance is intended for household use. If used for business, it is suggested to examine the product every other month.

When the belt is sliding, please follow the above method to lubricate the running board.

CONSOLE OPERATIONS

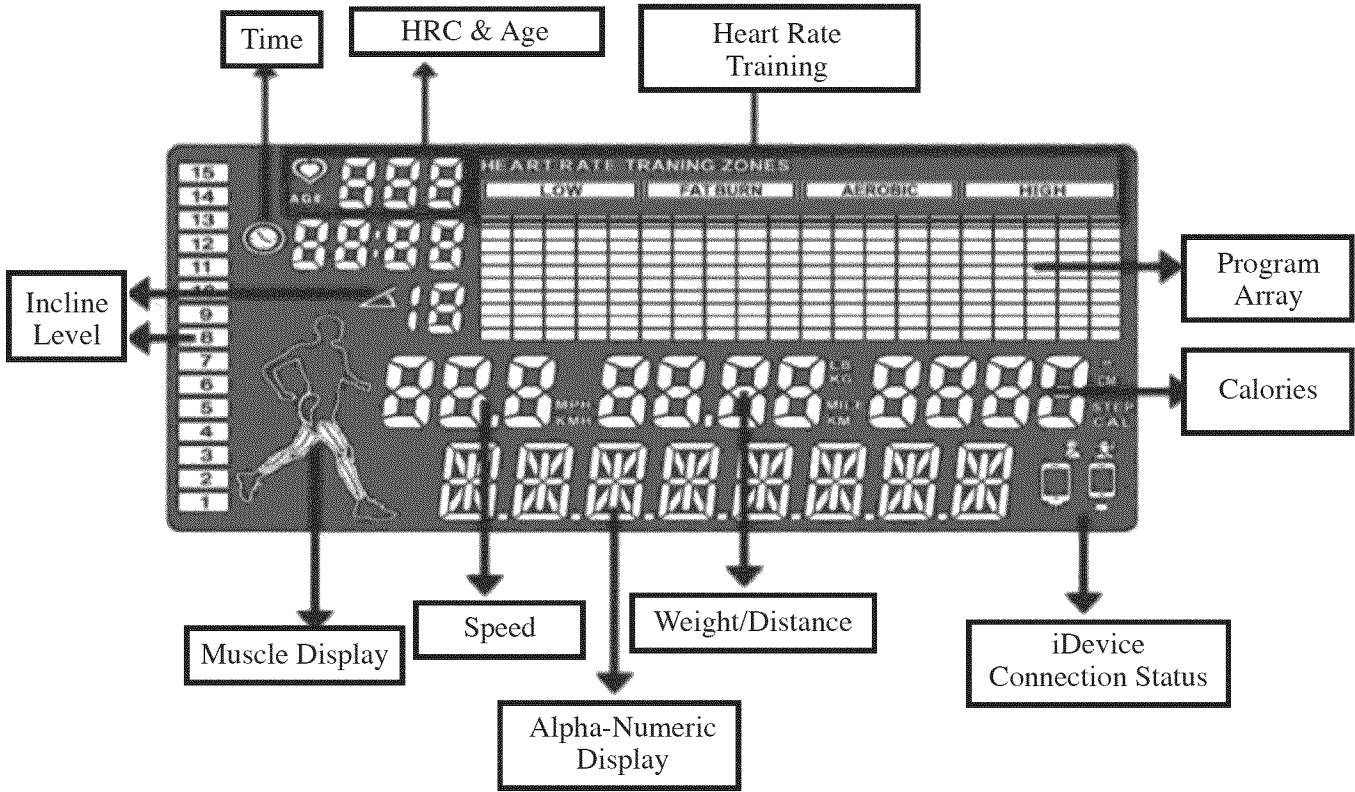
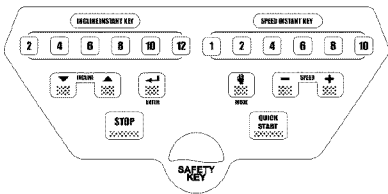
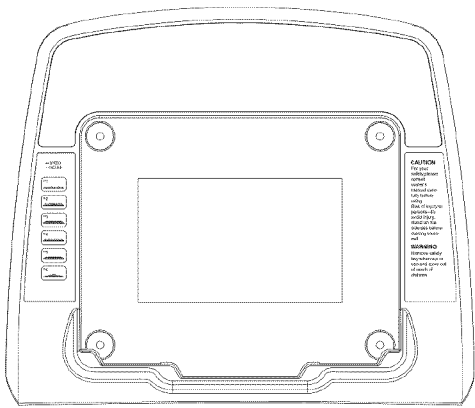

ABOUT THE MUSCLE DISPLAY

When the USER changes the incline level it will display on the screen.

Level 0

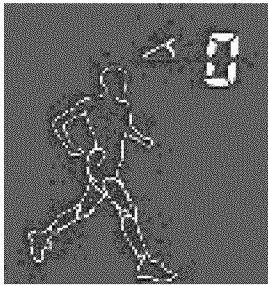

Levels 1-3

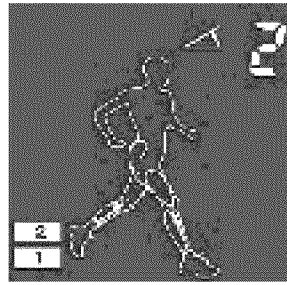

Levels 4-6

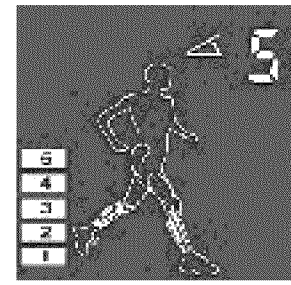

Levels 7-9

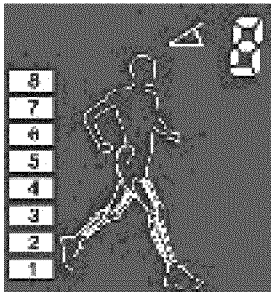

Levels 10-12

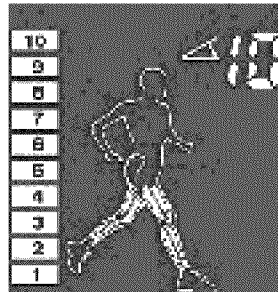

Levels 13-15

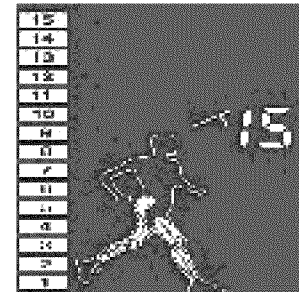

SPECIFICATIONS:

ENTER: To confirm all setting values

MODE: To switch Program Mode

START: To start training

STOP: 1) In training stage, pressing stop will pause the program. 2) In pause stage, pressing stop for "4" seconds puts the program into idle status. 3) In general, pressing stop will take you back to the previous function

INSTANT INCLINE: Adjusts Incline to levels 2/4/6/8/10/12

INSTANT SPEED: Adjusts Speed levels to 2/4/6/8/10/12 (by miles)

FUNCTION:

TIME Displays the workout time while exercising

SPEED Displays the current speed

DISTANCE Displays distance while exercising

PULSE 30-240 BPM

CALORIES Counts calories while exercising

RPM Displaying crank speed in revolution per minute

GETTING STARTED

Idle & Sleep

- Idle: Plug and open machine, the buzzer will sound and light up the screen (Figure 1, 2).
- Sleep: When the machine is left in pause for a certain amount of time, the computer will go back to Idle mode and enter into sleep.
- Sleep Status (light off screen).
Note: Engineer can adjust the amount of time before entering sleep mode in Engineer Mode II--F01.
- Setup Weight
 1. SPEED+ or SPEED- Edit Weight, the default is 70 Kg.

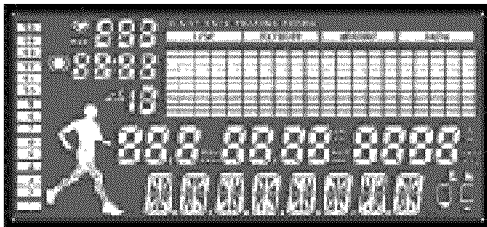

Figure 1

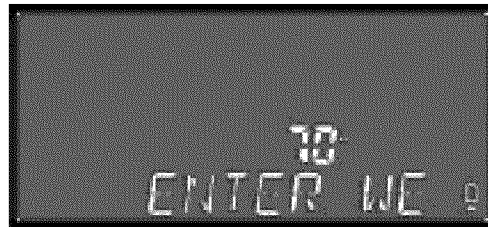

Figure 2

START TRAINING

How to Start Training

Press START (or Quick START) button can Enter into Training directly. The Screen will show "Ready" and count down 3 seconds.

In Training Status:

1. Press Incline Instant button or INCLINE+ or INCLINE- to adjust the Incline Level.
2. Press Speed Instant button or SPEED+ or SPEED- can adjust the Speed value.

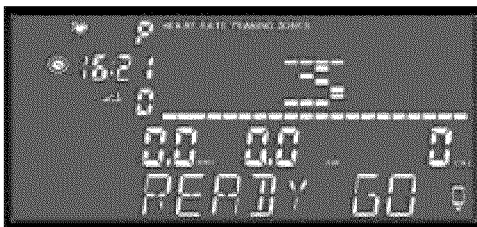

Figure 3

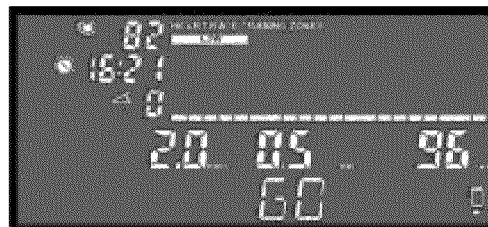
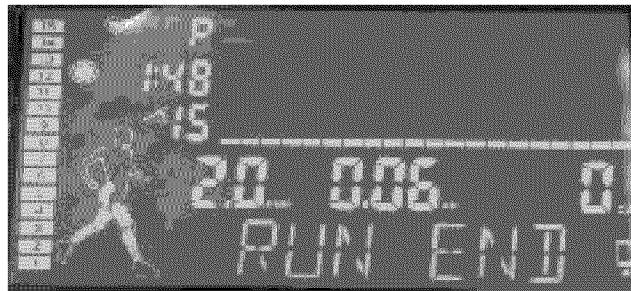

Figure 4

How to Pause / Stop

1. In Training Status, press STOP/RESET to enter into Pause status.
2. In Finish Target Value (Time/Distance/Calories), the Motor will stop and show "RUN END" on the screen.
3. In Pause Status or RUN END, User can Press STOP/ RESET buttons for 4 seconds to back to Idle Mode.



PROGRAM

1. Press ENTER to enter your weight into the Program Selection Status.
2. In Program Selection Status, User can press Mode button to switch the Program Function. MANUAL P1, P2, P3, P4, P5, P6, RANDOM, USER, H.R.C.1-3.
3. Pressing the STOP button will bring you can back to the previous Function Page.

MANUAL

1. Press ENTER to select Manual and enter the Target Time Setup. Press SPEED+ or SPEED- to setup target time. (Time Scale: 0:00, 20:00~99:00).
2. Press ENTER to input your target time and enter into the Target Distance Setup. Press SPEED+ or SPEED- to setup target distance. (Distance Scale: 0.00~99.00).
3. Press ENTER to input your target distance and enter into the Target Calories Setup. Press SPEED+ or SPEED- to setup target calories. (Calories Scale: 0~9990).
4. When you have finished your set up, press START to enter Training.

P1 (9 HOLE): INCLINE & SPEED

1. Press ENTER to select MANUAL and press SPEED+ or SPEED- to select P1. Press ENTER and Press SPEED+ to setup Level (Level 1 ~ Level 10).
2. Press ENTER to get into the Target Distance Setup. Although the display will show "Enter Distance", the distance is fixed and cannot be changed. Press SPEED+ or SPEED- to setup Distance (Distance Scale: 0.5~99.5 KM/Mile).
3. Press ENTER to input the default target distance. The Screen will show "Ready Go" and count down 3 seconds to enter the training mode.

P2 (HILL CLIMB): INCLINE & SPEED

1. Press ENTER to select MANUAL and press SPEED+ or SPEED- to select P2. Press ENTER and Press SPEED+ to setup the Level (Level 1 ~ Level 10).
2. Press ENTER to input the level and to enter into the Target Time Setup. Press SPEED+ or SPEED- to setup Target Time. (Time Scale: 20:00~99:00).
3. Press ENTER to input the target time. The Screen will show "Ready Go" and count down 3 seconds to enter the training mode.

Note: P3-P6 operation is the same as P2.

RANDOM (Random Speed)

1. Press ENTER to select MANUAL and press SPEED+ or SPEED- to select RANDOM. Press ENTER to get into Target Time Setup. Press SPEED+ or SPEED- to setup the target time. (Time Scale: 0:00, 20:00~99:00).
2. Press ENTER to input the target time and enter into the Target Distance Setup. Press SPEED+ or SPEED- to select target distance. (Distance Scale: 0.00~99.00 KM/Mile).
3. Press ENTER to input the target distance and enter into the Target Calories Setup. Press SPEED+ or SPEED- to select target calories. (Calories Scale: 0~9990).
4. When you have finished your training setup, please press START to enter into Training.

USER (USER CAN EDIT SPEED & INCLINE PROFILE)

1. Press ENTER to select MANUAL and press SPEED+ or SPEED- to select USER. Press ENTER to get into the User Program and selection status.
 - (1) Press SPEED+ or SPEED- to choose U1, U2, U3, U4.
 - (2) Press ENTER for 3 seconds, enter into edit profile status. Press SPEED+ or SPEED- to edit Speed profile shape.

Press INCLINE+ or INCLINE- to Incline profile shape

Press ENTER to select the next stage.

Press ENTER for 3 seconds to finish edit.

2. Press ENTER to Select U1 and enter into Target Time Setup.

Press SPEED+ or SPEED- to setup target time. (Time Scale: 0:00, 20:00~99:00).

3. Press ENTER to input the target time and enter into the Target Distance Setup.

Press SPEED+ or SPEED- to select target distance. (Distance Scale: 0.00~99.00 KM/Mile).

4. Press ENTER to input the target distance and enter into the Target Calories Setup.

Press SPEED+ or SPEED- to setup the target calories. (Calories Scale: 0~9990).

5. When you have finished the setup, please press START to enter into Training.

Note: Only one target (Time, Distance, Calories) can be setup for each U1-U4 training.

H.R.C 1-3

Press ENTER to select H.R.C 1-3.

Press SPEED+ or SPEED- to select 60%, 75%, THR (Target Heart Rate).

Note: In HRC Program, the computer will only accept the "Wireless Heart Rate Signal" (we suggest using a wireless heart belt). If no pulse signal is detected for 45 seconds, the computer will stop and show "No Pulse" automatically.

1. 60%, 75%

(1). Press ENTER to select 60% (or 75%) and enter into the Target Time Setup. Press SPEED+ or SPEED- to select the target time. (Time Scale: 0:00, 20:00~99:00)

(2). Press ENTER to input the target time and enter into the Age Setup. Press SPEED+ or SPEED- to select User Age. (Default 30 years old).

(3). Press ENTER to input your age and enter into the Target Heart Rate Setup. Press SPEED+ or SPEED- to adjust.

(4). Press ENTER to input the target heart rate. The screen will show "Ready Go" and count down 3 seconds to enter into the training mode.

2. THR (Target Heart Rate)

(1). Press ENTER to select your THR and enter into the Target Time Setup. Press SPEED+ or SPEED- to select the target target time. (Time Scale: 0:00, 20:00~99:00).

(2). Press ENTER to input the target time and enter into the Target Heart Rate Setup. Press SPEED+ or SPEED- to setup target heart rate (Default 72).

(3). Press ENTER to input your target heart rate. The screen will display "Ready Go" and count down 3 seconds to enter Training.

PROGRAM REVIEW

MANUAL

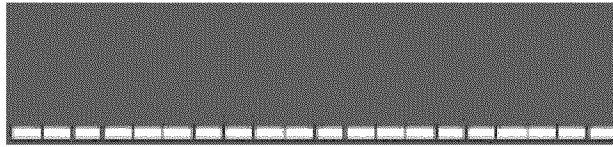

P1 9 Hole

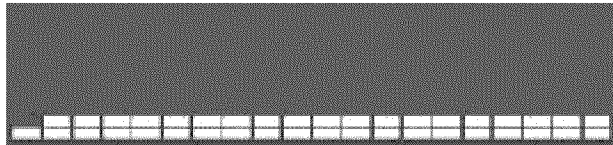

P2 Hill Climb

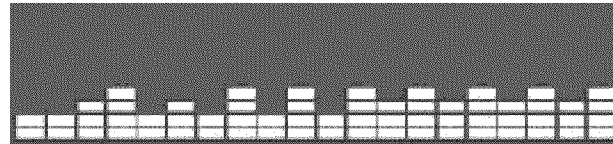

P3 Hill Run

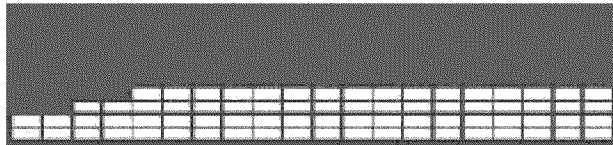

P4 Interval

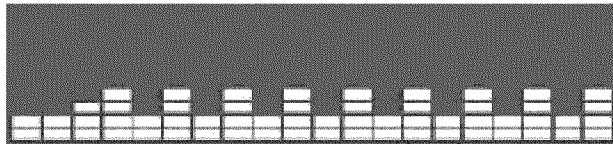

P5 Rolling

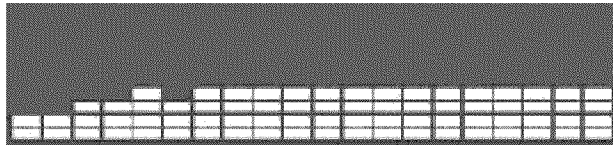

P6 Weight Loss

Hidden Area

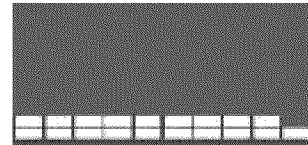

Hidden Area

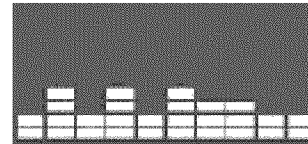

Hidden Area

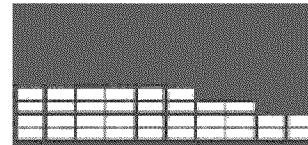

Hidden Area

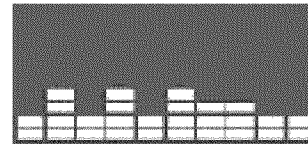

Hidden Area

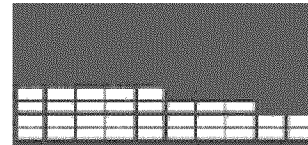

Hidden Area

RANDOM

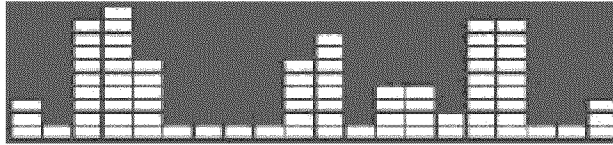

USER

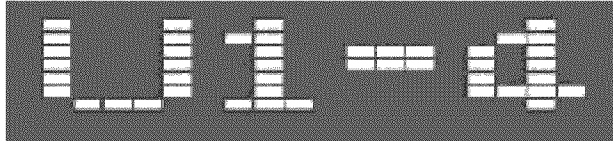

HRC 1-3

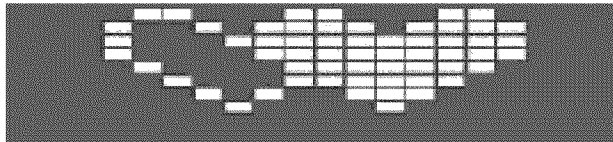

HRC 60%

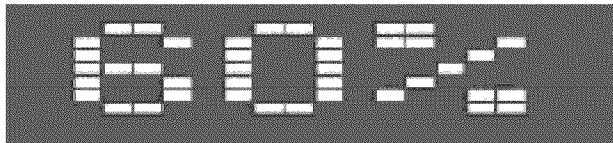

HRC 75%

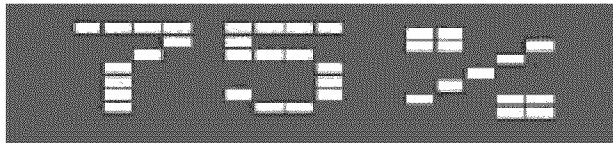

HRC THR

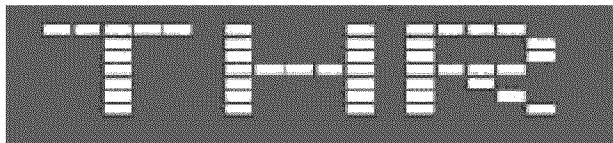

SAFETY KEY & ERROR WARNING

Safety Key Unplug:

1. When the safety key is unplugged, the machine will stop automatically and display “SAFETY OFF” on the Screen.
2. If the user plugs the safety key back in, the machine will re-start and enter into Idle Mode.

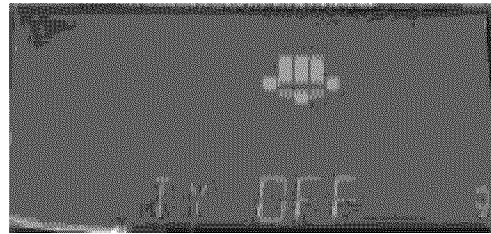
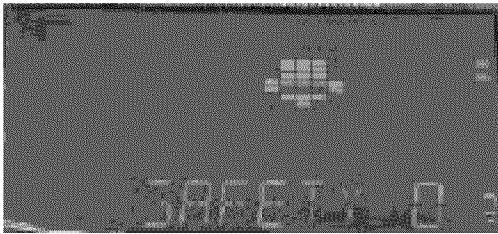

Error Warning:

When there is an error, the machine will stop automatically and display an “Error Message” on the screen.

1. E1 Can not detect Speed Vaule.
2. E6 The Incline Data is incorrect.
3. E7 The Incline AD Vaule is outside the normal range.

Troubleshooting:

- E1: Restart machine. Please call for service, if E1 still appears.
- E6: Restart machine. Please call for service, if E6 still appears.
- E7: Press Stop & Incline + (-) at the same time and start to adjust the AD value (on the screen).

OPERATING WITH AN iPod®/iPhone®/iPhone®

Insert iPod/iPhone/iPhone into the dock ensuring that the connector has been inserted correctly and the device sits firmly on the connector in the dock itself.

Note: Before connecting the device, you must download a PAFERS application from the APP STORE.

Here are the devices that this machine is compatible with:

- iPod touch (4th generation)
- iPod touch (3rd generation)
- iPhone 4S
- iPhone 4
- iPhone 3GS
- iPad 2
- iPad

Bladez Fitness i.Concept products are compatible with Apple devices with iOS 4.2.3 or later. It is recommended to update iOS to latest version to obtain the best user experience.

“Made for iPod,” “Made for iPhone,” and “Made for iPad” mean that an electronic accessory has been designed to connect specifically to iPod, iPhone, or iPad, respectively, and has been certified by the developer to meet Apple performance standards. Apple is not responsible for the operation of this device or its compliance with safety and regulatory standards. Please note that the use of this accessory with iPod, iPhone, or iPad may affect wireless performance. iPad, iPhone, iPod, iPod classic, iPod nano, iPod shuffle, and iPod touch are trademarks of Apple Inc., registered in the U.S. and other countries.

MAINTENANCE AND CLEANING

Care has been taken to assure that your equipment has been properly adjusted and lubricated at the factory. It is not recommended that the user attempt service on the internal components. Instead, seek service from an authorized service center. However, you may clean the outer surface. Use a soft cloth, dampened with warm water. Do not use aerosol sprays or pump bottles as they may deposit sediments upon the console surface. The use of harsh chemicals will destroy the protective coating and cause a static build-up that may damage the some of the components.

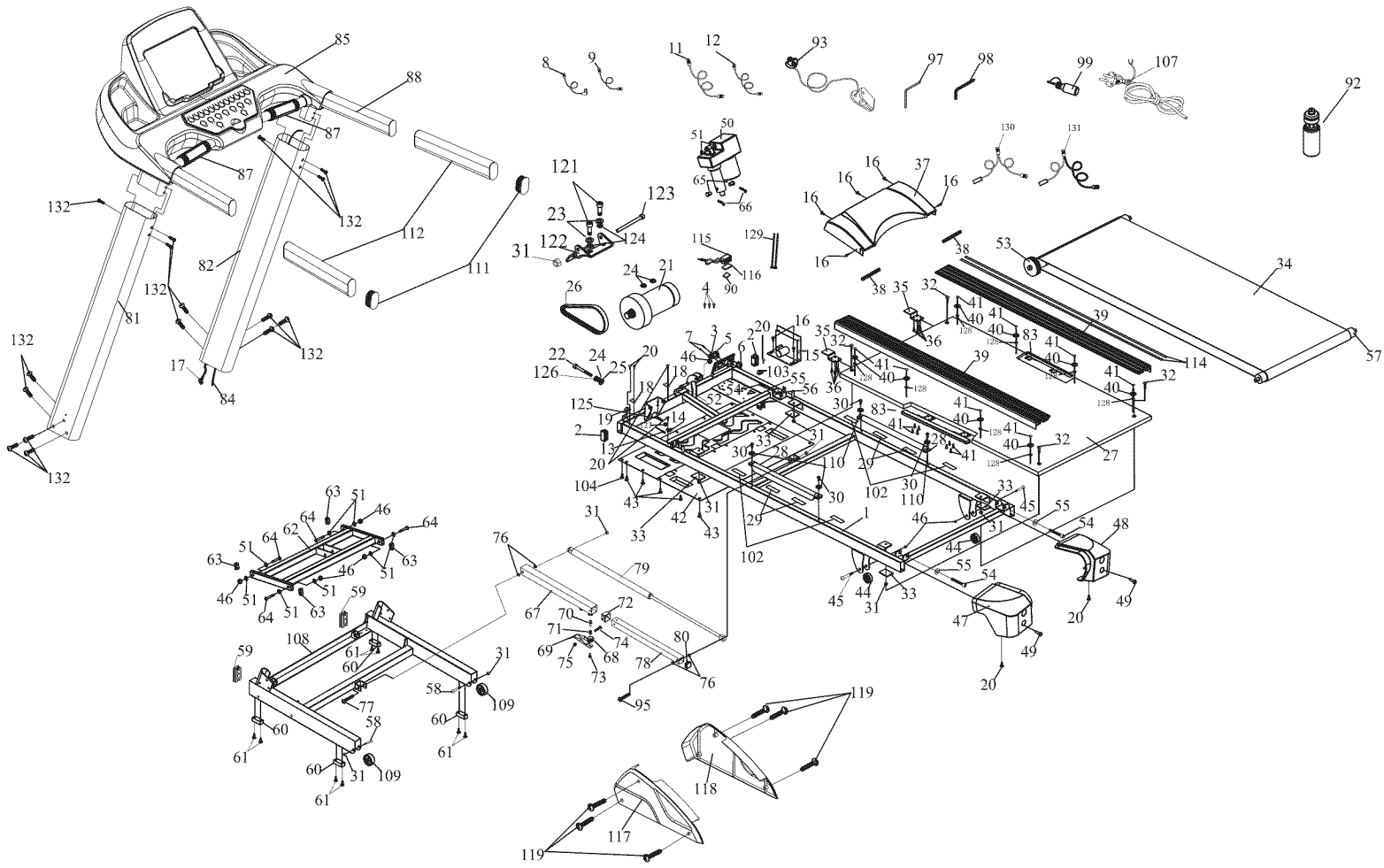

EXPLODED VIEW DRAWING

PARTS LIST

To order replacement parts: provide your customer service representative with the product model number and the part number located on the Parts List below, along with the quantity you require.

No.	Description	Qty.	No.	Description	Qty.
1	Frame Assembly	1	62	Incline Base Assembly	1
2	End Cap	2	63	End Cap	4
3	Power Wire Socket	1	64	Truss Hex Screw	4
4	Round Head Philips Screw	3	65	Clevis Pin	2
5	Power Switch	1	66	R-Pin	2
6	Circuit Breaker	1	67	Lower Folding Flex Tube	1
7	Round Head Philips Self-Tapping Screw	2	68	Nut	1
8	Extension Wire (White)	1	69	Pedal	1
9	Extension Wire (Black)	1	70	Bolt	1
11	Extension Wire (Black)	1	71	Spring	1
12	Extension Wire	1	72	Inner End Cap	1
13	Sensor	1	73	Truss Philips Screw	1
14	Sensor Base	1	74	Truss Philips Screw	1
15	Controller Set	1	75	Nylon Nut	1
16	Truss Philips Screw	7	76	Plastic Post Pad	4
17	Control Wire(Lower)	1	77	Truss Hex Screw	1
18	Wire Clip Knob	2	78	Upper Folding Flex Tube	1
19	Wire Clip Knob	1	79	Cylinder	1
20	Washer Drilling Philips Self-Tapping Screw	7	80	End Cap	1
21	Motor	1	81	Upright Left	1
22	CKS Hex Screw	1	82	Upright Right	1
23	Spring Washer	2	83	Shock Tube Assembly	2
24	Rubber Pad	3	84	Guide Thread	1
25	Washer	1	85	Computer Console	1
26	Drive Belt	1	87	Hand Pulse Set	2
27	Running Board	1	88	Computer Holder Assembly	1
28	Air-Shock	2	90	KSS wire clip fixing seat	1
29	Double Sided Tape	4	92	Bottle	1
30	Truss Philips Screw	4	93	Safety Key Sets	1
31	Nylon Nut	9	95	Truss Hex Screw	1
32	Socket Hex Screw	4	97	L Hex Wrench	1
33	Foam Sticker	4	98	Hex Wrench+Plus Screw Driver	1
34	Running Belt	1	99	Silicon	1
35	Running Board Extension Plate	2	102	Rubber Pad	4
36	Truss Philips Self Tapping Screw	8	103	Wire Clip Knob	1
37	Upper Motor Cover	1	104	Truss Philips Self-Tapping Screw	5
38	Sound Insulation Pad	2	107	Power Wire	1
39	Pedal	2	108	Base Assembly	1
40	Pedal Fixing Plastic	8	109	Wheel	2
41	Truss Philips Self-Tapping Screw	24	110	Washer	4
42	Lower Motor Cover	1	111	Oval End Cap	2
43	Philips Self Tapping Screw	14	112	PVC Foam Grip	2
44	Wheel	2	114	Foam Sticker	2
45	Truss Hex Screw	2	115	Transformer	1
46	Nylon Nut	7	116	Double Sided Tape	1
47	Rear End Cap(Left)	1	117	Left Decorative Cover	1
48	Rear End Cap(Right)	1	118	Right Decorative Cover	1
49	Round Head Drilling Philips Self-Tapping Screw	2	119	Truss Philips Self-Tapping Screw	6
50	Incline Motor	1	121	CKS Hex Screw	2
51	Plastic Washer	10	122	Motor Fixing Plate	1
52	CKS Hex Screw	1	123	CKS Hex Screw	1
53	Front Roller	1	124	Washer	2
54	CKS Hex Screw	3	125	Spring	1
55	Washer	3	126	Spring Washer	1
56	Hex Nut	1	127	Anti-skid Washer	1
57	Rear Roller	1	128	Washer	8
58	Truss Hex Screw	2	129	Bolts	2
59	End Cap	2	130	Transformer Power Wire (black)	1
60	Foot Pad	4	131	Transformer Power Wire (white)	1
61	Washer Drilling Philips Self-Tapping Screw	8	132	Truss Hex Screw	16

WARRANTY

RESIDENTIAL WARRANTY

Bladez Fitness will repair or replace, free of charge, at its option, parts that are defective as a result of material or workmanship. Lifetime replacement warranty coverage on frame and Three (3) year on other parts. Labor warranty coverage is one (1) year. Warranty covers the original consumer purchaser only.

THIS WARRANTY DOES NOT COVER

- Pre-delivery set-up.
- Components that require replacement due to dirt or lack of regular maintenance.
- Expendable items which become worn during normal use.
- Repairs necessary because of operator abuse or negligence or the failure to operate and maintain the equipment according to the instructions contained in the Owner's Manual.

For more detailed warranty information or to register your product warranty easily online, visit our website at: <http://www.Bladezconcept.com>

* Applies to defects from the manufacturer only.

FOR WARRANTY REPAIRS, PLEASE DO NOT TAKE YOUR MACHINE BACK TO THE RETAIL STORE. CONTACT BLADEZ FITNESS FIRST.

BH North America Corporation
20155 Ellipse
Foothill Ranch, CA 92610
Phone: 949.206.0330; Toll Free: 866.325.2339; Fax: 949.206.0013
Web: www.BHFitnessUSA.com
Mon - Fri 8am - 5pm PST